

# Table of Contents

## Agilent Technologies Test & Measurement Catalog 2001

<b>1 Introduction, Indexes &amp; New Products</b>		<b>6 RF &amp; Microwave Systems</b>		<b>12 Component Test Instruments</b>	
Agilent Overview	2	EMI/EMC Test Systems	334	Overview	482
Agilent's Web Site	3	Antenna & Radar Cross-Section Measurements	337	Impedance Measuring Instruments	485
How to Use This Catalog	4	Signals Development & Intercept Solutions	338	Materials Test Equipment	491
Subject Index	6	Phase Noise Measuring Systems	341	LCR & Resistance Meters	494
Product Number Index	26	RF & Microwave Measurement Systems	342	Additional Literature	501
Complete Test Solutions	36	Additional Literature	346	<b>13 Frequency &amp; Time Standards</b>	
New Products for 2001	40	<b>7 Wireless Communications Instruments &amp; Systems</b>		Frequency & Time Standards	504
<b>2 Support &amp; Services</b>		Overview	348	Additional Literature	508
Quick Selection Guide	68	Digital Microwave Radio Test Equipment	352	<b>14 Cable &amp; Broadcast Television Test Equipment</b>	
Support Overview	69	Wireless Mobile & Base Station Test Sets	353	Digital Video Test Equipment	510
<b>1</b> Hardware & Software Support Services	70	Cellular/PCS Transmitter & Receiver Test Equipment	379	Regulatory Test Equipment	513
<b>2</b> System Integration Services	74	Wireless Network Air Interface Testing	392	Maintenance Test Equipment	515
<b>3</b> Consulting & Engineering Services	76	Pager Test Equipment	395	Broadcast TV Analyzers	516
<b>4</b> Educational Services	77	Additional Literature	397	<b>15 Electronic Manufacturing Test Systems</b>	
<b>5</b> Channel Partners	79	<b>8 Wireline Communications Instruments &amp; Systems</b>		Board Test & Inspection Systems	518
<b>6</b> <b>3 Design &amp; Test Software and Systems</b>		Overview	400	Functional Test	519
<b>7</b> Instrument to Network Connectivity Initiative	82	Protocol Analyzers	402	Semiconductor Test Systems	520
<b>8</b> Communications EDA Software	84	Digital Transmission Testers	404	Semiconductor Measurement Instruments	523
<b>9</b> Test Software	86	SONET/SDH Test Sets	410	Data Storage Test Systems	526
<b>10</b> MMS Products	90	Field Installation & Maintenance	413	Additional Literature	528
<b>11</b> VXIbus Products	93	Voice Testing	417	<b>16 Mechanical &amp; Physical Test Instruments and Systems</b>	
<b>12</b> System Switches	97	Additional Literature	418	Data Acquisition Systems	530
<b>13</b> Interface Products	101	<b>9 Aerospace &amp; Defense</b>		Additional Literature	536
<b>14</b> Additional Literature	103	Overview	422	<b>17 Laser Interferometers/Encoders &amp; Laser-based Calibration Systems</b>	
<b>15</b> <b>4 General Purpose Instruments</b>		Electronic Warfare, Radar, Weapons & Satellite Test Solutions	423	Laser Interferometers/Encoders & Laser-based Calibration Systems	538
<b>16</b> Oscilloscopes	106	Signal Analysis	425	Additional Literature	544
<b>17</b> Oscilloscope Probes & Accessories	124	Physical Test	426	<b>18 Rack Solutions &amp; Accessories</b>	
<b>18</b> Modulation Domain Analyzers	132	<b>10 Digital Systems Debug, Verification &amp; Characterization</b>		Cabinets & Cabinet Accessories	546
<b>19</b> Electronic Counters	137	Characterization Tools & Solutions	430	Operating & Transit Cases	552
<b>20</b> Digital Multimeters	145	Verification Tools & Solutions	440	Cables & Adapters	554
<b>21</b> Data Acquisition & Switching Function Generators & Waveform Synthesizers	154	Logic Analysis & Emulation Solutions	442	<b>19 Purchasing Alternatives</b>	
DC Electronic Loads	165	Additional Literature	463	Refurbished Equipment, Trade Up, Leasing & Finance	558
Power Supplies	169	<b>11 Lightwave Instruments</b>		<b>20 Quotations, Warranties &amp; Local Assistance</b>	
AC Source/Analyzers	192	Optical Component Test	466	Quotations, Warranties and Terms of Sale	562
Additional Literature	194	Spectrum Analyzers	472	Local Assistance & Sales Offices	563
<b>5 RF &amp; Microwave Instruments</b>		Optical Wavelength Meters	473	<b>21 Agilent Publications &amp; Handbooks</b>	
Signal Sources	198	CD Test Solutions & Polarization Analyzers	474	Free Application Notes	576
Signal Analyzers	227	Digital Communication Analyzers	475	Free Test & Measurement Specialty Catalogs	599
Network/Spectrum Analyzers	266	Lightwave Converters & Signal Analyzers	477	Free T&M Quarterly Newsletters	602
Network Analyzers	271	Component Analyzers	478	Technical Handbooks Available Through McGraw-Hill	603
Power Meters	303	Additional Literature	480	Call Centers	604
Noise Figure Analyzers	310	<b>12 Component Test Instruments</b>			
Amplifiers	315	Overview	482		
RF & Microwave Test Accessories	318	Impedance Measuring Instruments	485		
Additional Literature	331	Materials Test Equipment	491		
		LCR & Resistance Meters	494		
		Additional Literature	501		
		<b>13 Frequency &amp; Time Standards</b>			
		Frequency & Time Standards	504		
		Additional Literature	508		
		<b>14 Cable &amp; Broadcast Television Test Equipment</b>			
		Digital Video Test Equipment	510		
		Regulatory Test Equipment	513		
		Maintenance Test Equipment	515		
		Broadcast TV Analyzers	516		
		<b>15 Electronic Manufacturing Test Systems</b>			
		Board Test & Inspection Systems	518		
		Functional Test	519		
		Semiconductor Test Systems	520		
		Semiconductor Measurement Instruments	523		
		Data Storage Test Systems	526		
		Additional Literature	528		
		<b>16 Mechanical &amp; Physical Test Instruments and Systems</b>			
		Data Acquisition Systems	530		
		Additional Literature	536		
		<b>17 Laser Interferometers/Encoders &amp; Laser-based Calibration Systems</b>			
		Laser Interferometers/Encoders & Laser-based Calibration Systems	538		
		Additional Literature	544		
		<b>18 Rack Solutions &amp; Accessories</b>			
		Cabinets & Cabinet Accessories	546		
		Operating & Transit Cases	552		
		Cables & Adapters	554		
		<b>19 Purchasing Alternatives</b>			
		Refurbished Equipment, Trade Up, Leasing & Finance	558		
		<b>20 Quotations, Warranties &amp; Local Assistance</b>			
		Quotations, Warranties and Terms of Sale	562		
		Local Assistance & Sales Offices	563		
		<b>21 Agilent Publications &amp; Handbooks</b>			
		Free Application Notes	576		
		Free Test & Measurement Specialty Catalogs	599		
		Free T&M Quarterly Newsletters	602		
		Technical Handbooks Available Through McGraw-Hill	603		
		Call Centers	604		

Use our test and measurement resources and services often!

[www.agilent.com/find/catalogue](http://www.agilent.com/find/catalogue)

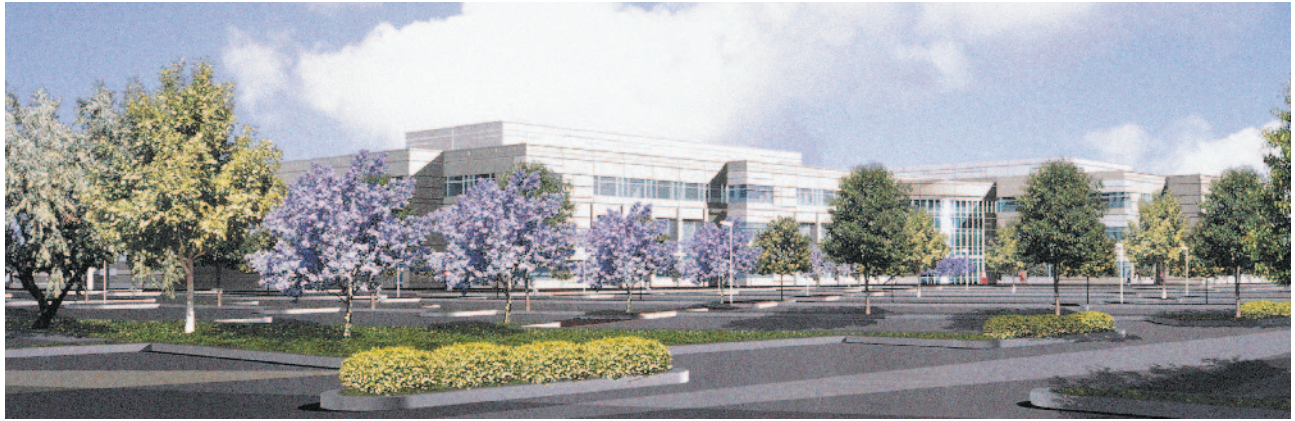

### About This Catalog

The Agilent Technologies 2001 Test and Measurement catalog brings you a tremendous range of high quality technology products, as well as many advances in measurement and test technology that provide optimized solutions. This includes the basic tools of test and measurement, all the way to complete systems that focus on emerging electronic and communications fields. For over sixty years we have developed products and services that are unequalled in their ability to help you improve your engineering results and contribute to your business and personal success.

In response to your comments and suggestions, we've restructured the catalog to make it easier for you to find the information that you need. See pages 4 and 5 for an overview of how to use the catalog.

### New Products

The "New Product" section (pages 40-64) highlights some of our most recent product introductions, such as these exciting developments:

- 16702B Logic Analysis Mainframe
- 54600 Oscilloscope Series
- E4991A Impedance/Material Analyzer
- 89600 Series Vector Signal Analyzer
- E8356A Series Network Analyzers
- Omni/BER 725 Communications Performance Analyzers
- TestExec SL Software Platform

### Support and Services

We continue to increase our technical support, resources and professional services to help you get the most from your Agilent Technologies experience. See Chapter 2 (page 67)

for a comprehensive description of "Total Support." For special needs or situations requiring customized test and measurement solutions, our professional consultants can help you make the right selection.

### Total Commitment to Quality

We are dedicated to providing quality products and services that meet your changing needs. Agilent Technologies employees uphold high standards for performance, reliability and service. The standards set by our Quality Maturity System (QMS) exceed the intent of ISO 9000, the international standards for quality management and quality assurance.

Nearly all Agilent Technologies divisions and calibration laboratories worldwide are ISO 9000 registered, which requires periodic audits by independent experts. Selected laboratories are accredited to the high standards of ISO Guide 25. The integrity ensured by these periodic audits enables many customers to augment their own internal quality systems without the expense of hiring audit teams. We include an ISO 9000 compliant calibration certificate with almost every new instrument to make it easier for you to put your Agilent equipment into service immediately.

### Agilent Technologies Web Site

We expand our World Wide Web site ([www.agilent.com/find/tmc](http://www.agilent.com/find/tmc)) to meet your requests for more information about Agilent Technologies products and services. We encourage you to visit the site, where you can obtain updated technical information and download application notes, interac-

tive selection guides and free demonstration software. The site gives you quick access to the latest news and training course schedules. See page 3 for our guide to on-line information services.

### Connectivity and Standards

To meet your needs for connectivity between instruments, systems, and networks, we design our products to fit into locally and publicly connected domains by using interfaces with industry standard and often computer standard protocols. For your convenience, we have identified these products with special symbols denoting their capabilities. See page 5 for information about these instrument functions.

In addition, Agilent is a significant contributor to the development of open industry standards on instrument connectivity with such activities as the IVI (Interchangeable Virtual Instrument) Foundation, as well as developing product capabilities, such as our connectivity software, that is described in detail on pages 82 and 83. Agilent's connectivity software allows instruments to communicate conveniently with computers and networks using the skills you already have, and minimizing the need to learn new applications. We are certain you will be interested in learning more about this next step in "user friendliness" and find that it is in keeping with Agilent's focus on helping you use your time to make measurements rather than learning how to use the instrument.

### Find test and measurement information and transact business on the Agilent Technologies web site

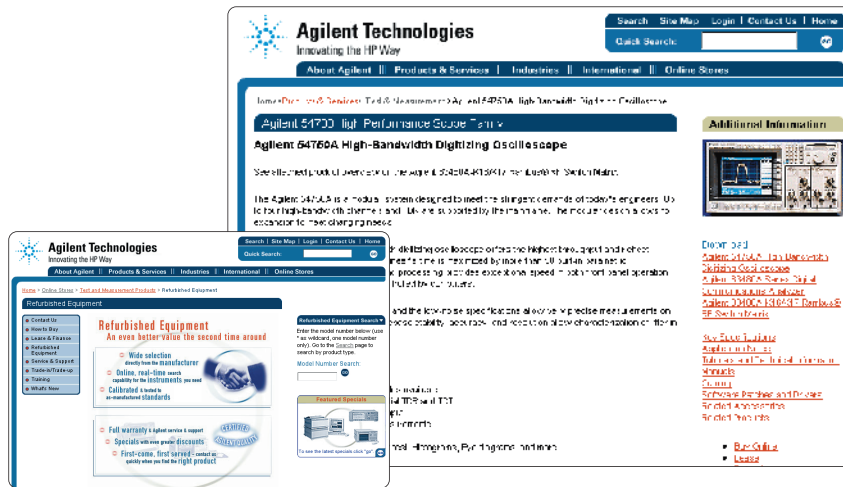

Take advantage of the vast and expanding range of information, support, and business resources, and services available at Agilent's redesigned web site.

The Agilent Technologies web site has been significantly redesigned and reorganized to be a more convenient, more efficient business tool and information resource. Our improvement process is ongoing. The new and expanded industry segment and product pages are easier to browse, making your investigations and activities pleasant and productive.

#### To keep up to date, visit often!

The content of our web site constantly varies as news happens, new products are introduced, application notes and brochures are published and updated, product evaluation tools and learning aids are added, sales promotions are initiated, and events are scheduled. You can keep up to date by browsing the web site regularly.

#### Find... Get... Buy...

The test and measurement information on the web site lets you take immediate action, at any time. You can use it to quickly:

- find, evaluate, compare, and select the products and services you need
- get updated, expert information for solving application problems
- get information on replacements for discontinued products
- buy some types of equipment, software, accessories, and parts online, using a credit card.\*

The web site also gives you access to the many support resources Agilent Technologies provides. For example, you can obtain information in your local language\*, check the status of your order, and more.

The product information pages provide quick access to overviews of instruments and systems, application notes, technical details, frequently asked questions, manuals, software, and explanations of accessories.

#### Helpful navigation aids

Buttons on the web page let you activate key functions or jump between major areas of the web site:

- Click on the *Search* or *Quick Search* button to quickly find specific information.
- Press the *Library* button to access the industry's most extensive range of application notes (printed and interactive), tutorials, technical papers, and many other helpful documents.
- Press the *Technical Support* button to access online help, software and drivers, frequently asked questions, service manuals and notes, the Metrology Forum, and much more.
- Use the *Log In* button to enter an online environment tailored to your specific interests.
- Activate the *Online Stores* button to place an order for selected Agilent selected test and measurement products.\*
- Hit the *News Releases* button to get the latest news information.
- Click on the *Events* button to see trade show and seminar schedules.
- Use the *Education* button to review training and education classes and courses on topics ranging from test and measurement fundamentals to advanced problem solving techniques.
- Click on the *Order Information* button to determine the latest information about your order.
- Activate the *About Agilent* button to learn more about the company and its history.
- Press the *Alliances* button to learn more about services and solutions offered by authorized Agilent Channel Partner companies.
- Click on the *Contact Us* button to find phone, fax, and e-mail information for Agilent offices and call centers.
- Use the *International* button to visit online resources in many countries.

Use our online test and measurement resources and services often!

[www.agilent.com/find/tmc](http://www.agilent.com/find/tmc)

\*Availability of this feature may be limited; an expansion program is ongoing. For best results, view the Agilent web site with Microsoft's Internet Explorer browser.



## Table of Contents

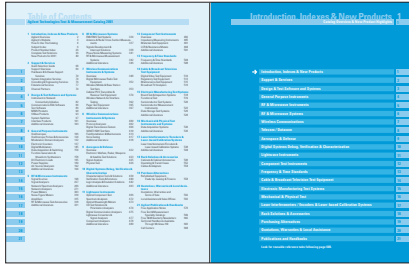

## New Products for 2001

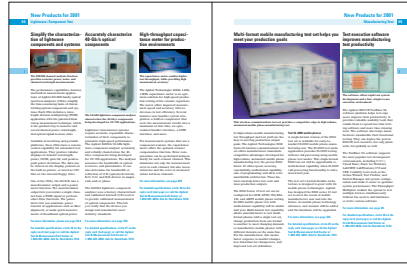

## Indexes

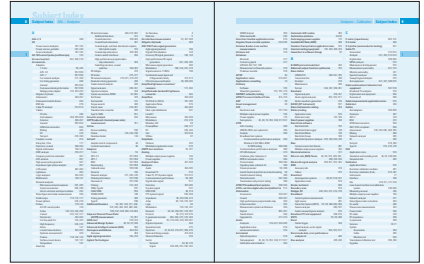

1

Easily find the major section of products or systems that you need. Refer to major sections by the number on the thumb tabs. Major sections and subsections are listed throughout the contents by page number. The contents of each major section and additional references are repeated for you on the first page of each section. [See page 1.](#)

Agilent Technologies introduces hundreds of new products each year. This full-color section features 48 new products for 2001 from Agilent's Test & Measurement Organization. These exciting and innovative new products reflect Agilent's commitment to research and development investments. They also illustrate major technology and market trends. [See page 40.](#)

There are two indexes in this catalog. The Subject Index references product categories, key terms, applications, and other useful information. [See page 6](#)

The Product Number Index allows you to find Agilent products if you already know their product numbers. All new products for 2001 are identified. Page numbers in bold type indicate the main references for that product. [See page 27.](#)

## Support & Services



This section provides you with an overview of the wide range of consulting and support services available through Agilent's Test & Measurement Organization. Agilent offers services and consulting for all phases of your test and measurement solution life cycle. [See page 68](#)

## Additional Literature & Product Notes



Agilent has published considerable additional information on the instruments noted at the end of most sections of the catalog. This includes focused data sheets, brochures and catalogs. In addition, Product Notes, written for specific instruments, are available on request. You may obtain this literature from our web site: [www.agilent.com/find/tmc](http://www.agilent.com/find/tmc), or use our convenient reply card in the back.

## Application Notes

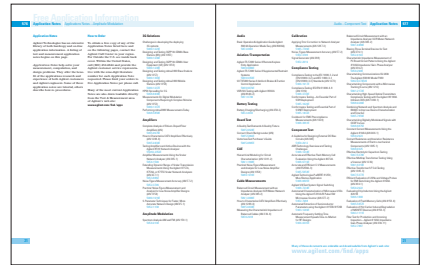

The 2001 Catalog contains a comprehensive listing of Application Notes, all of which are available to you free of charge. [See page 576.](#) This literature covers topics such as impedance, modulation, and semiconductors, and provides information to help you solve many test and measurement problems. A list of Application Notes is also available from our web site: [www.agilent.com/find/tmc](http://www.agilent.com/find/tmc)



# Product Descriptions

**A Signal Sources**

**B High-Performance RF Signal Generators**

**E**

- 10 kHz to 1280 MHz frequency range
- < -147 dBc/Hz SSB phase noise at 10 kHz offset
- 0.1 Hz frequency resolution



8662A

**F 8662A/8663A Synthesized Signal Generators**

Spectral purity is the key contribution of both the Agilent 8662A and 8663A, making them ideal for many radar, satellite communication, and phase noise measurement applications. Typical absolute phase noise performance of these generators at a 1 kHz offset is as low as -135 dBc/Hz, depending on the band of operation.

The frequency range of the 8662A is 10 kHz to 1280 MHz. It offers versatile AM/FM, using either internal 400 Hz and 1 kHz rates or externally applied modulating signals which can be either ac or dc-coupled. It also has simultaneous modulation capability.

The 8663A and 8662A provide the U.S. Air Force MATE (Modular Automatic Test Equipment) capability, via Option 700. This option is an external translator that allows the signal generator to be controlled by the MATE language CHL (Control Interface Intermediate Language).

**8662A Specifications**

**Frequency Range:** 10 kHz to 1280 MHz (1279.9999998 MHz)

**Resolution:** 0.1 Hz (0.2 Hz above 540 MHz)

**Accuracy and Stability:** Same as reference oscillator

**Internal Reference Oscillator:** 10 MHz quartz oscillator. Aging rate <math>< 5 \times 10^{-7}</math> /day after 10-day warmup (typically 24 hrs. in normal operating environment).

**Spectral Purity**

**Front-Panel Absolute SSB Phase Noise (dBc/Hz):**

Frequency range (MHz)	0.01 to 119.9 <sup>1</sup>		120 to 159.9 <sup>1</sup>		160 to 319.9 <sup>1</sup>	
	Spec	Typ	Spec	Typ	Spec	Typ
1 Hz	-68	-78	-66	-76	-60	-70
10 Hz	-98	-108	-96	-106	-90	-100
100 Hz	-116	-126	-115	-125	-109	-119
1 kHz	-126	-132	-129	-135	-124	-130
3 kHz	-126	-135	-129	-138	-124	-133
5 kHz	-128	-138	-131	-141	-126	-136
10 kHz	-132	-138	-142	-148	-136	-142
100 kHz	-132	-139	-142	-148	-136	-142

**Residual SSB Phase Noise (dBc/Hz):**

Frequency range (MHz)	0.01 to 119.9 <sup>1</sup>		120 to 159.9 <sup>1</sup>		160 to 319.9 <sup>1</sup>	
	Spec	Typ	Spec	Typ	Spec	Typ
10 Hz	-108	-114	-112	-119	-106	-113
100 Hz	-121	-126	-122	-129	-118	-124
1 kHz	-128	-133	-131	-138	-127	-134
3 kHz	-128	-136	-131	-139	-127	-135
5 kHz	-129	-138	-133	-141	-129	-136
10 kHz	-132	-137	-142	-147	-136	-142
100 kHz	-132	-137	-142	-147	-136	-142

**320 to 639.9<sup>1</sup>**

Frequency range (MHz)	320 to 639.9 <sup>1</sup>		640 to 1279.9 <sup>1</sup>		1280 to 2559.9 <sup>1</sup>	
	Spec	Typ	Spec	Typ	Spec	Typ
10 Hz	-100	-107	-93	-101	-88	-95
100 Hz	-112	-119	-105	-112	-100	-108
1 kHz	-121	-128	-115	-122	-109	-116
3 kHz	-121	-129	-115	-123	-109	-117
5 kHz	-123	-130	-117	-124	-111	-118
10 kHz	-131	-136	-124	-130	-118	-124
100 kHz	-131	-136	-124	-130	-118	-124

**Option 003 Specified SSB Phase Noise for Rear-Panel 640 MHz Output:**

Frequency range (MHz)	Spec	Typ
1 Hz	-54	-64
10 Hz	-84	-94
100 Hz	-104	-114
1 kHz	-121	-126
3 kHz	-121	-127
5 kHz	-129	-138
10 kHz	-145	-149
100 kHz	-157	-159

**SSB Broadband Noise Floor in 1 Hz BW at 3 MHz Offset From Carrier:**  
 <math>< -146</math> dBc for fc between 120 and 640 MHz at output levels above -10 dBm.

**H** Internet URL [www.agilent.com/find/tmc](http://www.agilent.com/find/tmc) Product & Order Info 8am-8pm EST 1-800-452-4844

**C**

8662A  
8663A

**D**

**G**

1

5

The body of this catalog contains over 10,000 new and existing test and measurement products and accessories from Agilent. Although not every Agilent product is included, you will find all relevant references to other sources.

**A General product headline**

Identifies the broad product category of the instrument, system or service described in the section.

**B Product description**

Defines the specific purpose and function for the product described.

**C Product number**

Defines the specific Agilent model numbers and versions that are described on the page.

**D Section tab number**

Relates to the Section numbers identified in the Table of Contents, and defines a product family.

**E Product features**

Give an “at-a-glance” view of the key features of the products on the page.

**F Specific product identification**

Defines the features and specifications of one model in the family of products on the page.

**G Product attribute marks**

Define, by symbols described below, which special features or services apply to this product.

**H Agilent action and help locations**

## Symbols



The QuickShip symbol, used in the ordering information, indicates specific products available for quick delivery. To order QuickShip items, call 1-800-829-4444.

Outside the U.S. contact your local call center or sales office to order products available through QuickShip.



This symbol identifies all new products for 2001 throughout the general products and systems pages.



This symbol is used throughout the catalog and identifies products that have GPIB (IEEE-488) capability.



This symbol identifies products that include an Agilent interface for simplified FTP and NFS LAN/WAN remote access and control via an X11 window display. This Agilent networked user interface adds instrumentation resources to client-server computing systems and increases the capability of existing network connections.

## A

### ac power sources

Analyzers	192-193
Portable	254

### ACPR (Adjacent Channel Power Ratio)

measurement	383
-------------	-----

### ADS (Advanced Design System)

	59, 84, 260
--	-------------

### ADSL (Asymmetrical Digital Subscriber Line)

	408-409, 518
--	--------------

### AM/FM

Agile signal generator	199
Digital I/Q modulation, ESG-D/DP series	
digital RF signal generators	205-208
Economy RF signal generators	200-204
High-performance RF signal generators	209-213
Microwave signal generators	214
Modulation	198, 210, 223-224
ESG-A/AP series analog	
RF signal generators	202-204
ESG-D/DP series digital	
RF signal generators	205-208
Source modules	225
Pulse signal generators	198-224
Signal sources to 110KHz	
Synthesized swept signal and	
CW generator family	221-222
VXI microwave synthesizer	216, 218
AM/FM/Phase signal generators	199, 211-213

### AM/FM/Pulse-Modulation

signal generators	199, 217
-------------------	----------

### AM/PM/FM demodulation

	260
--	-----

### AMPS

Mobile phone test	363, 365, 367
Test solutions	43, 55, 350, 363, 365, 367

### ARCNET networks, testing

	401
--	-----

### ARM

Motorola	442
Processor debug	444

### ATE

Electronic loads	165-168
Multiple output power supplies	179
Power supplies	185
Simulation subsystem	218

### ATM

Additional literature and product notes	419
Advisor LAN analyzer, and	402
Analysis	408
Communications performance analyzers	411

### Access loop test

	413, 518
--	----------

### Accessories

Adapters	
APC-3.5	555-556
APC-7	555-556
For network analyzer	285
For timing generator	439
Wedge probe adapter	128, 460-461
Alligator clip leads	499
Antennas	336

Attenuators/Switch drivers	318, 324-327
Cable TV analyzer	513-514
Cables	
50 ohm	439
Adapters, and	554-556
GPIB interconnection	554
Mating	499
Couplers, coaxial	330
Delay line, 22ns	123
Detectors, coaxial	328-329
Digital multimeters	152-153
EMC analyzer	336
High-power pulse generator	438
LCR meters	496-497
Lightwave	477
Logic analyzers	460-461
Multimeters	152-153
Network analyzers	292-294, 284-285
Noise figure and scalar measurements	250
Oscilloscope	124-131
Preamplifiers	336
Probes	
Active	130, 254, 270
Current	131, 153, 336
Differential	61
Elastomeric	460-461
For fine-pitch ICs	128, 460
High bandwidth	61
High frequency	254
High voltage	131
Kelvin	153
Locator base solutions	460-461
Optional accessories for	461
Passive	124-126, 131
Resistor divider	131
Scope	61, 124-131
Surface-mount device	153
Surface-mount probing accessories	128
Temperature	153
RF & microwave	
Additional literature	332, 599
Coaxial detectors	328-329
Coaxial fixed attenuators	327
Coaxial single- and dual-directional	
couplers, 90μ hybrid coupler	330
Coaxial step attenuators	325-326
Custom switch interfaces	318
High-performance programmable	
step attenuators	324
Switching solutions,	
coaxial switches	320-323
RF network analyzers	284-285
Resolution timing generator	439
Scalar network analysis	250
Signal analyzers	250
Spectrum analyzer	254
Switching solutions	319
Test	
Fixture	493
Lead kits	153

Torque wrench	439
Transit cases	293
Transition time converter	439
Type N, SMA	555
Active probes	130, 254, 270
ActiveX controls/automation	87
Adapters	
APC-3.5	555-556
APC-7	555-556
BNC	555-556
Banana plug	555-556
Detector	277
Kits	302
Network analyzer	285, 461
Probing	128, 460
SMA, Type N	555
SMA/SMB	556
TDMA/CDPD	357
Timing generator	439
Type N	556
Additional literature—see Literature	
Adjacent channel power	
measurement	42, 231, 242
Advanced design system	59, 84
Advisor testers	402
Aerospace & defense products	421-426, 441
Agile signal generator	199, 223-224
Agilent Technologies	
Application notes, free	576-598
CaLan	513
Call centers	604-605
Channel Partners	79, 459
Communicating with	562
Financing	66, 68
Overview	2
Signal Studio	218
Specialty catalogs	599-601
Support options	68
T&M quarterly newsletter	602
Web site	3
Alligator clip leads	499
Amplified	
Lightwave converters/receivers	123, 477
Wide bandwidth lightwave converter	477
Amplifier test, RF	520-522
Amplifiers	
50/60 Hz to 400 Hz	192-193
Application Notes	576
Distribution	507
RF and Microwave	254, 315-317
Modules, VXI	93
Preamplifiers	254
VXIbus	96
Amplitude flatness test system	352
Amplitude modulation	
ESG-A/AP series analog RF signal	
generators	202-204
Application notes	576

<b>Analog</b>	
RF signal generators	202-204
Signal sources	202-204
<b>Analysis</b>	
Logic	63-64, 442-463
Probes	455-458
<b>Analyzers</b>	
12 Gb/s BER	406
ac source	192
Audio	390-391
Broadcast TV	516
Cable TV	513-515
Channel	473
Communication performance	51, 411-412
Digital communications	53, 406
Distortion	390-391
EMC/EMI	49, 336
FFT dynamic signal	114, 262-263, 265, 515, 535
Impedance/Material	47, 409, 487-488
Jitter	92, 135, 404, 409, 412
Lightwave component	54, 472, 478
Logic	63-64, 442-463
Modulation	41, 132-136, 257-258
Network	48, 266-302, 402, 584
Noise figure	50, 310-314
Optical spectrum	54, 472
PCI-X	62, 440-441
Polarization	474
Protocol	50, 408-409, 586
Semiconductor parameter	58, 522-523
Signal	92, 204, 227-270, 339, 382-387, 477
Spectrum	49, 91-92, 204, 227-249, 259, 348-351, 472, 484
Telecom/Datacom	404, 408-409
Network	48
Signal	41-42, 259, 262, 264, 388
Time interval	132, 135
Vector signal	41-42, 260-265
WDM channel	473
<b>Anechoic chamber application notes</b>	576
<b>Angular/Linear encoder systems</b>	542-543
<b>Antenna &amp; radar cross-section measurements</b>	337
<b>Antenna positioner encoder</b>	337
<b>Application notes</b>	576-598
<b>Arbitrary</b>	
Source	532
Waveform generators	56, 60, 158-163, 207, 218
<b>Asset management</b>	68
<b>Attenuators</b>	
Attenuator/switch drivers	318
Coaxial	325-327
Interconnect kits	325
Lightwave	471
Measurement systems architecture	318
Optical	471
Programmable step	324
Upgrade kits	286

<b>Audio</b>	
Analyzers	227-229, 390-391
Application notes	576
<b>aurora testers</b>	408
<b>Automated</b>	
Optical inspection	518
Test Executive	86
Test equipment	48, 55-56
<b>Automatic drift routine</b>	473
<b>Automation tools</b>	89
<b>Autoranging power supplies</b>	185
<b>Aviation/transportation application notes</b>	576
<b>Avionics testing equipment,</b>	
<b>ac power sources</b>	192-193
<b>B</b>	
<b>BASIC</b>	
Bundles	101
Instrument	535
Windows, for	87, 89
<b>BER test equipment</b>	51-52, 205-208, 407-409
<b>Balanced</b>	
Components	337
Output, function synthesizer	159
<b>Base station</b>	
CDMA PCS	359-360, 381
Connection kits	357
Maintenance software	358
Test sets	356-362, 375-376
<b>Baseband</b>	
Signal analyzers	338-340
Vector signal analyzers	262, 264, 512
<b>Basis, power supplies</b>	185
<b>Battery testing</b>	
Application notes	576
Electronic loads	165-168
Emulation	46, 173
<b>BenchLink software</b>	
Arb	161, 163
Data Logger	154
Scope	114
Spectrum Analyzer	240, 246
<b>Benchmarking</b>	396
<b>Bias</b>	
Current source/text fixtures	496
Multiple output power supplies	179
<b>BitAlyzer</b>	43, 121, 405-406
<b>Bit error rate (BER)</b>	
Analysis	405-407
Test	526-527
Tester	51-53, 404, 406, 412
<b>Bluetooth</b>	
Microwave source	46, 217
Signal analyzer	262-265, 388
<b>Board test and inspection systems</b>	518, 528
Application notes	576
<b>Books, technical</b>	603
<b>Boundary scan</b>	518

<b>Bridges, RF</b>	254, 278, 286
<b>Broadband</b>	
Control system measurements	515, 535
Series test system	601
Service analyzer	535
<b>Broadcast TV test equipment</b>	516
<b>Burst</b>	
Carrier trigger	254
Signal analysis, vector signal	
analysis	262, 264, 512
<b>Bus analyzer</b>	62, 440-441
<b>Buying plans for Agilent equipment</b>	66, 558
<b>C</b>	
<b>C meter (capacitance)</b>	498
<b>C-V meter</b>	483
<b>CAE</b>	
Application notes	576
Simulation	59, 84, 388
<b>CATV test equipment</b>	510, 513-514
<b>CD test solutions</b>	474
<b>CD-ROM, ac power source, product for</b>	192-193
<b>CDMA (Code Division Multiple Access)</b>	
Air-interface measurement systems	392
Base station test	356-360, 381
cdma2000	41, 43, 45, 379
cdmaOne	233, 379, 381
Cell site testing	
Cellular adapter	357-358
Cellular/PCS base station test set	359-360
Channel simulator	384
Digital RF signal generators	389
Drive test	43, 392-394
IS-2000 mobile phone test	363, 366-367
Measurement personalities	205-208, 227, 381-383
Mobile station service test	368-369
PCS base station	359-360
Software	368-369, 371
Spectrum analyzer	227, 262, 381
Test systems	377
Transmitter test	379, 381-383
<b>CDPD cellular adapter</b>	357
<b>CEPT digital circuits</b>	404
<b>CW (Continuous Wave)</b>	198
Frequency measurements	135, 137
Generators	198, 214, 246
Microwave	
Counters	138, 141
Signal generators	214, 221
Sensors	308
Signal sources	198, 214
VXI microwave synthesizer	46, 216-218
<b>Cabinets &amp; cabinet accessories</b>	546-551





Lightwave	54, 472, 478
Memory device	57
Relay	489-490
Resistor	487-488, 490
Resonator	489-490
Semiconductor	489-490
Switch	489-490
Transformer	489-490
Transistor	489-490
VCO	344
Varicap diode	487-490
<b>Computer-aided test</b>	87
<b>Computer-standard technologies</b>	40
<b>Computer-verification tools</b>	440-441
<b>Computers &amp; peripherals application notes</b>	577
<b>Connecting instruments to PCs</b>	82-83
<b>Connectivity software</b>	82-83
<b>Consulting services</b>	68, 76, 90
<b>Consulting services</b>	
Engineering	68, 76
Support	67, 77, 98
<b>Containers</b>	552-553
<b>Control system application notes</b>	578
<b>Controllers, VXIbus</b>	93, 95, 101, 471
<b>Converters</b>	
50/60 Hz up to 1000 Hz	192-193
Analog to digital	154, 426, 530-535
Downconverter	262, 264
GPIB	554
Lightwave	123, 477
Microwave	256
Optical/Electrical	477
Transition time	439
<b>Counters</b>	137-144
CW microwave	138
High-precision oscillators	137
MMS	91
Microwave and millimeter-wave frequency	137
Microwave counter/power meters	143
Overview	137
Pulse/CW microwave	138, 144
RF	137, 139
Time-interval	137-138
Universal	137-139
<b>Couplers, coaxial</b>	330
<b>Crystals, application notes</b>	578
<b>Current</b>	
Measurement	165-168, 173-174, 176-180, 185
Probes	128, 131
Source	176
<b>Custom test sets systems</b>	36-39, 74, 259, 294

**D**

<b>DBS noise source</b>	312
<b>dc</b>	
Consumption current	344
Coupled lightwave converters	477
Electronic loads	165-168, 195

Power supplies	46, 62, 169-192, 353
Source/monitor	525
<b>DCA</b>	121-122, 475
<b>DCCH Test</b>	354
<b>DCS</b>	44, 350
<b>DCS 1800</b>	350
<b>DECT</b>	
Measurement personalities	227, 382, 384
Signal generator	205-208, 350
Test set	350
Test solutions chart	350
Transmitter test	350, 382, 384
<b>DMCA radio test personality</b>	388
<b>DMMS test accessories</b>	91, 145, 148, 150, 152-153
<b>DQPSK signal generator</b>	206-208
<b>DRC (design rule checker)</b>	84
<b>DS1/0</b>	408
<b>DS1/DS3 testers</b>	411-412
<b>DS3 test set</b>	412
<b>DSL</b>	
ADSL	408
HDSL	408
<b>DSP, design and synthesis</b>	84, 262-263, 265, 549
<b>DVB</b>	
QAM Analyzer	510-511
<b>DVMs</b>	143, 145-153, 194
<b>DWDM</b>	52, 54, 410-411, 470
<b>Data</b>	
Acquisition	154-157, 426, 530-535, 578
Characterization solutions	431
Communications	348-418, 578
Control	534-535
Converters, application notes	418, 578
Generators	430-432
Modules, jitter	133
Storage test systems	526-527
Systems	530-535
Verification tools	133, 434-436, 438-439
Viewers	530
<b>Datacom/Telecom instruments and systems</b>	
Additional literature and product notes	418
DWDM test	410
Digital transmission testers	404, 408-409
Overview	400
Protocol analyzers	402-403
Testers	408-409
<b>Debuggers/Debugging</b>	63
Digital circuits	442
Interactive debugging solution	440
Third-party support	459
Tools	442, 445-447
<b>Deep memory</b>	59
<b>Defense satellite &amp; signal solutions</b>	422-426
<b>Delay</b>	
Line	123
Spread	392
<b>Demodulation</b>	252
<b>Design &amp; test software and systems</b>	
Additional literature	103
Automation	41, 59, 84
Environments	442

<b>Design guides</b>	59, 84
<b>Detectors</b>	
Adapters	277
Bridges, network analyzers and	285-286
Broadband directional	328
Coaxial	328-329
Precision	277
<b>Diagrams eye-contour</b>	406
<b>Dielectric</b>	
Constant	483, 492-493
Materials	489
Measurement system software	491-492
Probe kit	293, 491
Test	492-493
<b>Differential</b>	
Interferometers	539
Measurement	337
<b>Digital</b>	
Analyzers	53, 121-122, 475
Signal sources	205-208
Application notes	578
Characterization solutions	430-439
Communications	
Analyzers	53, 121-122, 475-476
Microwave source	46
Data tester	404, 412
Data transmission application notes	579
Design & debug, digital systems	62-64, 429, 442-462, 599
Design & test instruments/systems	430-431, 434-436, 438-439, 442
Additional literature and product notes	463
High-power pulse generator	438
Overview	442
DWDM test	410
IC test equipment & systems	520-523
I/Q microwave synthesizer	
Digital RF signal generators	205-208
Modulation	217
Logic analyzers	442-462
Measurement	46, 382, 395
Microwave	
Radio test equipment	352
Synthesizer	217
Modulation	
Analysis	259
Microwave synthesizer	217
Signal sources	217
Multimeters	91, 145-147, 149-153, 194
Nanovolt/Micro-ohmmeter	148
Scanning	154
Temperature/SPRT	148
Pattern generator	63, 453
Radio test equipment	348, 352
Signal analyzers	259
Radio test systems	259, 348, 352
Resolution timing generator	439
RF signal generators	205-208
Signals-to-Source	442





Fixed attenuators, coaxial	327
Fixtures, test	47, 57, 378, 488
Flash programming	518
Flex	200-201, 395
Flicker/harmonic test system	348
Phase modulation	350
Stereo composite mode, function synthesizer	159
Test solutions	350
Test source	257-258
FoIP	417
Form-C relay module (signal routing)	98
Fourier analyzers	227-228, 580
Frame relay protocol analyzer	402, 408
Free technical publications	68, 318, 576-602
Frequency	
Agile signal generator	223
Converters	256, 296
Counters	139
Domain analysis	41
Doubler	213
Modulation	202-208, 223-224, 580
Monitoring system	340
Standards	504-508
Synthesizers	198-199
Synthesizers, application notes	580
Time standards, and	92, 503-508
Labs and communication networks	504
Overview	504
Primary frequency standard	505-506
Stability, application notes	580
Time reference distribution, and	504, 506
Transient	344
Function generators & waveform synthesizers	60, 158-164, 194
Functional test systems	
12 Gb/s BER	406
Digital verification	430
Software	86
System for communication products	518-519
VXI	93

**G**

GFSK	
Measurement	206-208
Signal generator	206-208
GMR head test	526-527
GMS	44
GPIB	
Accessory modules	99
Cards and kits	101
GPIB-to-Centronics parallel bus converter	554
Interconnection cables	554
Interface products	101-102
GPRS	
Mobile phone test	43, 363-364, 367
Test set	55, 403
GPS	
SmartClock technology, additional literature and product notes	508

GSM	
Air-interface measurement system	43, 392-394
Design Library	84
Drive test	43, 392-394
GSM900	350
Measurement personalities	227, 233, 382, 384
Mobile phone test	363, 367
Mobile/cellular radio test sets	375-376
Repair and calibration	373
Signal generator	205-208
Test sets	375, 403
Test systems	55, 377, 379
Transmitter test	381-382, 384
General purpose instruments	104-195, 601
Generators	
ac power	
Function	60, 158-163, 192-193
Pulse	192-193
AM/FM/Pulse	
Data	430
Digital I/Q modulation	205-208, 217
Economy RF signal	200-201
High-performance RF signal	210-213
Microwave signal generators	214
Pulse/Pattern	432
RF signal generators	202-204
Signal sources to 110 KHz	198
Synthesized swept and CW signal	221-222
Arbitrary waveform	60, 158, 161-163, 192-193
Custom modulation	202-208
dc power function, power pulse	192-193
Digital modulation	198, 205-208, 217, 223-224, 395
FM	258
Function	158-161, 163
High-power pulse	438
Microwave	199, 214, 219, 221
Noise	312
Pattern	63
Phase modulation	198-208, 211-214, 223-224, 395
Pulse	60, 158, 163
Pulse/Pattern	433
RF	198, 200-213, 223-224
Resolution timing	439
Signal	
Analog	223-224
Digital & analog	205-208
Digital I/Q modulation	205-208, 217
Digital modulation	395
GFSK	206-208
MMS	90
Microwave	214, 219, 221
RF	395
Sweep	158, 161, 163, 221
Synthesized	
Function generators and waveform synthesizers	158, 161, 163
Microwave sweepers	219-220
Pager test equipment	395
Signal sources to 110 GHz	198-199
Timing	439
Tracking	92, 254

Gigabit Ethernet	53
Global Positioning System (GPS)	580
Gradual purchase plans	66
Graphic Cell Compiler	84
Graphical	
Programming language, VEE	87-88, 531
Signaling emulation	50, 403
Group delay	
Application notes	580
Delay/amplitude flatness	272, 348, 351-352
Guides to customer support services and Agilent financing	68, 558

**H**

HDSL circuit installation & maintenance	409
HP-UX graphical programming software	87-88, 101, 531
HTBasic	89
Hand-off receiver control	38
Handhelds	
ADSL	408
ATM	408
DSL	408
Frame relay	408
ISDN	408
ProBER 2	404
T1/E1	408
TIMS	408
Hard disk drive test	526-527
Head test	526-527
High Frequency Structure Simulator (HFSS)	84
High-current biasing, precision LCR meters	496
High-dynamic range, time domain	262-265
High-frequency probe	302
High-impedance passive probes, accessories for	124-125
High-power	
Device measurements	292-293
Sweep generators	
Source modules	225
High-resistance meter	500
High-resolution interferometer	539
High-voltage probe	131
Histograms	117, 135
How to use this catalog	4-5

**I**

I/Q modulation	
Digital	98-99
Microwave synthesizer	217
Module	88-89
Demodulation	252
Modulation	205-208
IC	
Test systems	57-58, 520-523
Testing, application notes	580



EMI/EMC test systems	346
Electronic manufacturing test systems	528-529
Frequency/time standards and synchronization	508
General purpose instruments	194
Laser interferometers/encoders & laser-based calibration systems	544-545
Lightwave instruments	479-480
Logic analyzers	469
MMS products	103
Mechanical & physical test instruments and systems	536
Newsletters	602
Physical test instruments and systems	536
Protocol analyzers	418
RF & microwave instruments	331-332
RF & microwave systems	346
Signals development and intercept solutions	346
SONET/SDH test sets	419
System switches	331
Test software	103
VXIbus products	103
Wireless communications	397
Wireline communications instruments & systems	418
<b>Loaded PC board test</b>	518
<b>Loads, electronic</b>	62, 165-168
<b>Local assistance &amp; sales offices</b>	563-573
<b>Logic analysis &amp; emulation solutions</b>	63, 442-462
Additional literature and product notes	463
Application notes	582
Benchtop	442, 446
Bit-error-rate tester	430
Bus support	457-458
Cards	449-450
Digitizing oscilloscope modules	452
Emulation solutions and	63-64, 442, 462
Eye finder technology	450
Integrated oscilloscopes for	452
Microprocessor and bus interface	457-458
Modular	63-64, 442, 448, 452
Ordering information for	442
Overview	442
Pattern generator module	63, 442, 453
PCI series, in	440
Pentium processor interface, probe	442
Probes	442, 452
Probing accessories	460-461
Scope capability	452
Stimulus and response	442, 453
System frame	63, 449-450
Systems	443
Tests (digital verification)	430
<b>LogicWave</b>	445
<b>Low-frequency applications for signal analyzers</b>	390
<b>Low-leakage switch</b>	524
<b>Low-noise power supplies</b>	171-172, 179
<b>Low-thermal jumper sets</b>	153

**M**

<b>M-curve radio signature test set</b>	352
<b>M-modules</b>	95
<b>MDA test system</b>	518
<b>MMS (Modular Measurement Systems)</b>	
Additional literature and product notes for	103
Application notes	582
Catalog	90, 600
Overview	90
Products	90-92, 103
Signal analyzers	91
<b>MPEGScope digital video testers</b>	510
<b>MR head test</b>	526-527
<b>MSO</b>	108-112
<b>MUX, VXIbus switches</b>	96-97
<b>Machine tool calibration system</b>	541
<b>Magnetic</b>	
Dielectric material test solutions and	492-493
Maintenance test equipment	515
Material test	487-490, 492
<b>Mainframes</b>	
Electronic loads	165-168
Logic analyzer	442, 448, 452
Oscilloscope	106
<b>Maintenance</b>	
Application notes	582
Consulting, test and	76
Field installation, and	413
Manufacturing test	55-58, 86, 283, 287-290, 345, 377, 478, 518-528
Support services	70
Test equipment	361-362, 412-416, 515
<b>Manufacturing test</b>	55-58, 86, 283, 287-290, 345, 377, 478, 518-528
<b>Manufacturing test systems</b>	517-528, 599
<b>Mass interconnect products</b>	524
<b>Mass memory module</b>	247
<b>Matching transformer</b>	254
<b>Materials measurement</b>	47, 292, 483, 487, 491-493, 501, 582
<b>Matrix switches</b>	
Multiport coaxial switches	322-323
Semiconductor applications	524
VXIbus	96-97
<b>McGraw-Hill technical publications</b>	603
<b>Measurement</b>	
ac power source/analyzers	192-193
Automation	
Controllers	93
Microwave sources	221
Software	295
Swept network analyzers	271
Control application notes, and	582
Low current	58
Noise figure	520-522
Personalities	
Broadcast TV	516
CDMA	227, 242, 382-383
CT2-CAI	227, 242, 382, 385
Cable TV	233, 241, 513
cdma2000	227
Cellular/PCS transmitter test	382-386

DCS1800	227, 242, 382, 384
DECT	227, 242, 382, 384
Digital radio	227, 242, 247, 388
EDGE	227
EMC	241
GSM	227, 242, 382, 384
Link	227, 352
NADC-TDMA	227, 242, 382, 385, 388
Noise figure	241
PCS1900	382, 384
PDC	227, 382, 386, 388
PHS	227, 242, 382, 386, 388
Radar cross section	337
Scalar	241, 250
Signal analyzers	227, 233, 241, 250-251
Spectrum analyzers	227, 241, 381-386
TV broadcast	241, 516
W-CDMA	227
Power	520-522
Software	89
System, lightwave	468-469
<b>Measuring receiver</b>	255
<b>Mechanical</b>	
Acoustic test, and	532
Calibration kits	299-300
Physical test instruments & systems, and	
Additional literature	536, 583
Data acquisition systems	530-535
Dimensional measurements	542-543
Strain conditioning	533
Verification kits	299-300
<b>Media scanners, handheld</b>	401
<b>Mega Zoom</b>	59, 108-113
<b>Memory test system</b>	57
<b>Meters</b>	
Capacitance	54, 498
Digital multimeters	91, 143, 145-153, 194, 353
High-resistance	500
LCR and resistance	483-484, 494-500
Lightwave	473
MMS	306
Micro-ohm	148
Microwave	143
Microwave power	306-307
Milliohm	148, 499
Multi-wavelength, lightwave	473
Nanovolt	148
Noise figure	250, 310-311, 313-314, 332
Optical wavelength	473
Peak power	306
Power	54, 91, 143, 305-309
Precision LCR	495-496
RF Inductor	497
RF LCR	497
Resistance and LCR	483-484, 495-500
Temperature	148, 154
Thermistor	307
VXI	306
Wavelength	473





<b>Network signal analyzers</b>	
Digital communications	400, 418
DWDM, test solutions for	410
Fiber-optic	413, 415-416
Fixed, installing and maintaining	403
ITU-T	401
Linear	271-273
Maximizing uptime of	415
Optimization	396
PDH, testers for	400
Protecting	413
<b>Network spectrum analyzers</b>	266-270, 331
<b>Networks</b>	
Air interface testing	393-394
Application notes	584
ATM	419
Broadband	419
Communication test products	50-53, 400-418, 504
DWDM, test solutions for	410
Fiber-optic	413-416
Fixed, installing and maintaining	403
ITU-T	401
Linear	271-273
Maximizing uptime	415
Optimization	396
PHD testers for	400
Planning & design	346, 396
Protecting	402, 413
Protocol	418
Scanning or multiple-signal connections, for	98
SONET/SDH and /VXI, test solutions for	135, 400, 412
Synchronization standards	134
Wireless	41-45, 298, 348-397
<b>New products for 2001</b>	40-64
<b>Newsletters</b>	602
<b>Noise</b>	
Application notes	576
Figure	
Analyzers	50, 310-314
Measurement	50, 92, 251, 310-311, 313-314
Meters	250, 332
Scalar measurements, and	250
Test sets	314
Generators	312
Interference test set, and	352
Measurements	58
Phase	341
Sources	250, 312
Test set	352
<b>Non-contact</b>	
Positioning systems	542
Push-pin (NCP) sensors	542
<b>O</b>	
<b>O/E (optical-to-electric) converters</b>	477
<b>OADM</b>	52
<b>OC-48</b>	51, 407, 411-412
<b>OC-192</b>	51, 407

<b>OC-768</b>	407
<b>OSA</b>	54
<b>OSNR</b>	54
<b>OTDR (Optical Time Domain Reflectometer)</b>	413-416
<b>OXC</b>	52
<b>OmniBER</b>	411-412
<b>On-wafer</b>	
Device characterization	291-292
Measurements	297
<b>Online support</b>	68
<b>Open architecture</b>	82-83
<b>Open industry standards</b>	1
<b>Operating &amp; transit cases</b>	552-553
<b>Operating environments</b>	562
<b>Optical</b>	
Component analyzer	54
Component test	466-471
Converters	477
Fiber	416
Network field installation & maintenance	
Optical time domain reflectometer	414-416
Overview	413
Optical-to-electrical converters	477
Polarization controllers	415-416, 471
Spectrum analyzer	54, 472
Transmitter/Receiver	52, 476
Wavelength meters	473
<b>Optics, dimensional measurements</b>	539
<b>Optimization, EM</b>	84
<b>Ordering and repair</b>	562
<b>Oscillators</b>	137, 504, 576
<b>Oscilloscopes</b>	
500 MHz to 18 GHz trigger for	123
Accessories for	123-124
Additional literature	194, 601
Advanced triggering	117
Analog vs. digital	106
Analysis functions	106
Application notes	576
Bandwidth of	106
Channels	106
Choosing	124, 126
Color display	116-117, 452
Communication mask test	118
Connectivity software	116
Deep memory	59
Delay line for	123
Differential probe	61, 129
Digital al communications analyzer	53, 121
Digitizing	91, 107, 113, 452
Email on trigger	117
GPIO over LAN	116
General purpose	113, 115-118
High bandwidth	123
High channel count	452
High sample rate	116-118
Histograms	117
In a logic analyzer	452
Infiniium series	
Clip-on trackball	120
Communication mask test kit	120
Performance upgrade	120

Probes	120
Rackmount kit	120
TouchPad	120
Transit case	120
Interface	114
Lightwave converters for	123
MMS	91
Memory depth	106
Mixed signal	59, 108
Modules	114
Overview	106-107
Performance characteristics	119
Probes	61, 124-131
Probing	118
Pulse generators, for	123
Sampling speeds	106
Selecting	106-107
Software	61, 116
TDR/TDT probe and source	123
Triggering	106
Troubleshooting	107, 113
Video applications	114
Voice control	118
Web enabled	117
Wide-bandwidth	121-122, 475
<b>Oscilloscope probes &amp; accessories</b>	61, 124-131
<b>Over-air maintenance tool</b>	42, 361
<b>Overviews</b>	
Agilent Technologies	2
Complete solutions	68
Component test instruments	482-484
Data acquisition systems	530
Datacom/telecom instruments & systems	400
Defense, satellite & signal analysis solutions	422
Digital	
Design test instruments & systems	442
Educational services	77
Electronic counters	137
Field installation and maintenance	413
Frequency and time standards	504
Function generators & waveform synthesizers	158
Video test equipment	510
Voltmeters	145
Impedance measuring instruments	482
Infiniium oscilloscopes	116
Interface products	101
Logic analysis & emulation solutions	442
MMS products	90
Materials measurement	483
Modulation domain analyzers	132
Network analyzers	271-273
New products for 2001	40
Oscilloscopes	106-107
Power supplies	169
Signal analyzers	227
Signal	
Development & intercept solutions	338
Sources	198
Support services	68



High bandwidth passive divider	131
High-frequency	254
High voltage	131
Infinium	127, 129
Kelvin	153
Logic analyzer	460-461
Low-mass passive probes	127
Mini-sockets	126
Oscilloscope	61, 124-131
Passive	125-127, 131
Selection guide	124
Spectrum analyzer	254
Surface mount	127
<b>Probing accessories</b>	
TDR/TDT	123
Temperature	153
Wedge probe adapter	128, 460
<b>Process test systems</b>	518
<b>Processors</b>	
Execution control	449
Pentium	442
Support	443
<b>Product number index</b>	26-35
<b>Production</b>	
Capacitance meter	54
Costs	353
Test system software	55
Test, application notes	586
<b>Professional consulting services</b>	68, 90
<b>Programmable</b>	
Electronic loads	165-168
Languages	87-88, 531
Power supplies	173-174, 179, 181-184
<b>Protocol analyzers</b>	
Additional literature & product notes	418
Analysis	408-409, 586
Monitor	440
Purpose of	400
Signaling test sets	403
<b>Publications &amp; handbooks</b>	
Free publications	68, 576-602
Technical handbooks	603
Test & measurement	
Catalogs and directories	599-602
Quarterly newsletters	602
<b>Pulse</b>	
Characterization	92
/CW microwave counters	138, 144
Electronic loads	165-168
Frequency measurements	132, 144
Generators	60, 123, 158, 163, 430-439, 439
Mask measurement	404
Measurements	123, 163, 295, 404, 435-438, 586
Modulation generators	205-208, 223-224
Parameter definitions	433
/Pattern generators	432-436
Wavelength measurement	96, 473
<b>Pulsed-RF measurement capability</b>	295
<b>Purchasing alternatives,</b>	
<b>refurbished equipment, trade up,</b>	
<b>leasing &amp; finance</b>	558-559
<b>Q</b>	
<b>Q measurement</b>	495-496
<b>Q-factor analysis</b>	406
<b>QAM (Quadrature Amplitude Modulation)</b>	206-208, 223-224, 511
<b>QPSK</b>	206-208
<b>QoS</b>	417
<b>Quad-output power supplies</b>	179
<b>Quality</b>	
Service	417
Training, customer support	68
<b>Quick selection guide</b>	68
<b>QuickShip delivery service</b>	5
<b>Quotations</b>	
Local assistance & sales offices	563-573
Warranties and pricing	561-562
<b>R</b>	
<b>RF</b>	
Amplifiers	254, 315-317
Bridges	254, 286, 302
CAE	84
Communications	133-134, 350, 353-355
Counters	137, 139, 194
Coverage measurement system	392
Digital communication system	353
Downconverter	262, 264, 512
Economy network analyzers	286
Generators	198, 200-204, 210-213, 223
IC test systems	520-521
Impedance	
Analyzer	487-490
Material analyzer	485-486
Test kit	270
LCR meter	497
Measurement systems	342-345, 514, 516
Microwave measurement system,	
Additional literature and product notes	331
Modeling software, IC-CAP	85
Modulation	388
Multiplexers	96
Network analyzers	271-302
Network/Spectrum analyzers	266-270
Noise figure analyzers	310-314
Power meters	303-309, 344
RF/mixed-signal IC production test systems	520
Signal analyzers	204, 237, 257-258, 262, 264, 512
Signal characterization	262, 264, 512
<b>Signal generators</b>	
Analog	223-224
Digital	200-201, 223-224
Economy	198, 202-204
ESG-D/DP series	205-208
High-performance	198, 210
Personalities	205-208
Synthesized	395
Systems	234-346, 378
Sources	198-213, 223-224, 295
<b>Spectrum analyzers</b>	
Digital video signal	512
Portable	204, 232, 237, 240, 243-262
Vector signal	262
<b>Test</b>	
Accessories	318, 599
Equipment for communication	
satellite payload test	90
Systems	378
Transition measurement	342
Vector signal analyzers	264, 512
Video measurements and	514
<b>RF and microwave instruments</b>	46-49, 84, 196-332, 388, 485-490
Additional literature and	
product notes	318, 331-332
Amplifiers	315-317
Coaxial	
Detectors	328-329
Fixed attenuators	327
Single- and dual-directional couplers,	
90 $\mu$ hybrid coupler	330
Step attenuators	325-326
Custom switch interfaces	318
IC design	84
Impedance analyzer	487-488
Measurement systems	331, 342-343, 345
Network analyzers	271-302
Network/Spectrum analyzers	266-270
Noise figure analyzers	310-314
Power meters	305-309
Programmable step attenuators	324
Signal	
Analyzers	226-265
Generators	198, 216-218
Source modules	225
Sources	198-226
Switching solutions, coaxial switches	320-323
Test	
Accessories	318-330
Fixture	487-488
<b>RF and microwave systems</b>	333-346
Additional literature and product notes	346
Antenna and radar cross-section	
measurements	337
EMI/EMC test systems	334-336
Phase noise measurement solutions	341
Signals development and	
intercept solutions	338-340









Matrix	96-99, 154, 322, 524	Constant current/voltage, multiple output power supplies	179	TDR	121-123, 408, 475
Microwave	96, 98-99, 319-321	dc power supplies	177, 180	TDR/TDT probe source	123
Modules	155	DWDM test solution	410	<b>TETRA</b>	
Multiplexer	96	Design	84	RFIC test system	521
Multiport	322	Development & debug solutions	442	Signal generators	205-208
RF multiplexer	96, 155	Digital radio test	352	Test solutions	350
Switch/control unit	98, 155	Electronic loads	165-168	<b>TIA/EIA J36</b>	55
System	97-99, 554	Integration services	74-75	<b>TIMS (Transmission Impairment Measurement System)</b>	400, 408-409
Topologies	97	Manufacturing test	518, 523	<b>True harmonic distortion measurements</b>	228
Transfer	322, 327	Network analyzer accessories	277	<b>TS-50 RF/Mobile phone test fixtures</b>	378
Unit	154	Performance analysis tool set	454	<b>TV</b>	
VHF	98-99	Power supplies	86, 171-172, 175, 181-184	Broadcast measurement personality	241, 516
VXI bus	96-97	Support services	71-75, 520	Broadcast TV analyzer	516
<b>Switching</b>		Switches		Cable	
Application notes	588	Additional literature and product notes	103	Accessories	513-514
Instruments	154	Interconnect systems and cables	554	Analyzer	229, 513-514
<b>Symbols used in this catalog</b>	5	Transmit/receive module test	345	Digital TV	262-263, 265
<b>Synchronization, jitter analysis</b>	134	<b>System frame</b>		Digital video	511
<b>Synthesized</b>		Logic analysis systems	448	Maintenance test equipment	515
Arbitrary ac power waveforms	192-193	Measurements	64	Measurement personality	241, 513
Arbitrary waveforms	158, 161	Timing analysis and	442	Monitor personality	241
Function generators	158-163	<b>Systems</b>		Spectrum analyzer	227
Generators		Development	74	Sweep/Ingress analyzer	515
Analog RF signal generators	202-204	Development services	73	Test equipment	229, 241, 511-515
Digital RF signal generators	206-208	Harmonic/flicker test	192-193	<b>Tape recording, application notes</b>	588
Economy RF signal generators	200-201	Integration services	73, 75, 78	<b>Technical publications, free</b>	68, 318, 576-602
Function generators and waveform synthesizers	158, 161, 163	Lightwave component analyzers	478	<b>Telecom network test equipment</b>	408-409
High-performance RF signal generators	211-213	Manufacturing test	520-521, 523	<b>Telecom/Datacom instruments and systems</b>	
Microwave	46	Modular measurement	90	Additional literature and product notes	418-419
Pager test equipment	395	Semiconductor test	520	Digital transmission testers	404-409
Signal sources to 110 GHz	198	Support	71	Field installation & maintenance	413-416
Synthesized microwave sweepers	219-220	Test Executive	86	Network synchronization, additional literature and product notes	508
Microwave		Transmit/receive module test	345	Overview	400-401
Sources	198, 214, 219	VXIbus	93-97	Protocol analyzers	402-403
Sweepers	219-220	Wireless	350	SONET/SDH test sets	410-412
VXI	216-218	<b>T</b>		Test & measurement solutions	400-417
Signal		<b>T1/Datacom test sets</b>	404, 409, 518	Voice testing	417
Generator subheader	395	<b>T&amp;M quarterly newsletters</b>	602	<b>Telecommunications</b>	
Sources	198-199, 202-204, 210-214, 219, 221	<b>T-Carrier</b>		Application notes	588
Spectrum analyzer	353	Test equipment	412	Digital data transmission	352
Sweepers	198, 219, 221	Test sets	404, 411	DWDM test solution	410
Swept signal and CW generators	221-222	<b>T/R module test system</b>	345	Network management	416
<b>Synthesizers</b>		<b>TACS cell sites, installation and maintenance of</b>	356	Newsletter	602
Application notes	588	<b>TACS/ETACS test solutions</b>	348, 350-351	Power supply	173-174
Arbitrary waveforms	158, 161	<b>TCM test sets</b>	411	SONET/SDH	410-412
Frequency	199	<b>TDMA (Time Division Multiple Access)</b>		Signal generators	205-208, 389
Function generators	158, 161	Base station test	354, 356-357	Synchronization systems	200-201
Microwave	56, 91, 198-199, 214, 216-221	Cellular adapter	354-355, 358	Test equipment	
Multifunction	159-160	Drive test system	392-393	ac power sources	192-193
Overview	158	Measurement personality	227, 382, 385	Lightwave	135, 400, 412, 472, 474, 477
Signal generators	199	Mobile phone test	363, 365, 367	M-curve signature test set	352
Waveform	158-161, 163	Phone tester	354, 374	Microwave radio testing	352
<b>System</b>		Signal generators	205-208, 389	Multipath fading simulator	352
Accessories, network analyzers	278	TDMA/CDPD cell site test systems	357	Power meters	306-307
Amplifiers	317	Transmitter test	382, 385	SONET/ATM/T-carrier	135, 400
Board test	518			SONET/SDH/PDH/T-carrier	411
				ToolKit	408
				Transmission testers	404

- Telegra products 417
- Telephones, cellular 353-354, 379
- Television 227-229, 341, 511-516
- Temperature
  - Application notes 589
  - Coefficient testing 492
  - Measurements 148
- Temperature-compensated thermistor
  - mounts, power meters 307
- Terms of sale 562
- Test
  - Automation 518
  - Equipment 408, 510-515
  - Fixtures 47, 57, 378, 430, 488
  - Measurement information
    - Catalogs and directories 599-601
    - Education curriculum 77
    - Newsletters 602
    - Organization, Overview 1
  - Mobile phone test set 363-367
  - Port cables 301-302
  - Processor-per-pin architecture 57, 520
  - Products 363-367
  - Sets
    - 2 Mb/s 404
    - 12 GB/S BER 406
    - Access loop 518
    - AMPS MOBILE 363, 365, 367
    - Base station 357-358, 375-376
    - Broadband 297
    - CDMA PCS base station 359-360
    - CDMA IS-2000 mobile 363, 366-367
    - CDPD 357
    - Cell site 350, 357
    - Cellular phone 363, 365, 367
    - Cellular radio 350, 353
    - Custom 294
    - DCS1800 375-376
    - Duplexer 294
    - GSM 363-364, 367, 373, 375-376
    - GSM/GPRS 403
    - High Power 294
    - Interference 352
    - M-curve radio signature 352
    - MS test set 375-376
    - Microwave 297
    - Millimeter-wave 297
    - Mobile manufacturing 55
    - Mobile station 44, 350, 373, 375-376
    - Mobile/cellular radio 353, 397
    - Multipath fading simulator/
      - signature test set 352
    - Multipoint 284
    - Noise and interference 352
    - Noise figure 314
    - Optical fiber 416
    - PCS 363-365, 367, 403
    - PDL 471
    - RF communications 353-355
    - Radio 375-376
    - Reflection 250
  - S-Parameter 272, 283, 287-290, 295
  - SDH/SONET/PDH/ATM/T-carrier 411
  - SONET/SDH 412
  - SS7 403
  - Service 375-376
  - Signaling 403
  - T-Carrier 404, 412
  - TDMA 359, 363, 365, 367
  - Transmission/Reflection 272, 291
  - Software
    - Additional literature and product notes for 103
    - Design 86-89
    - Executive 55, 86
    - HTBasic for Windows 89
    - VEE visual programming language 87-88, 531
  - Strategy triangle 76
  - Systems
    - Additional literature and product
      - notes about 103
    - Application notes 589
    - Board 518
    - Cellular phones 377
    - DC parametric 520-521
    - dc power supply 62
    - DWDM test solution 410
    - Data storage 526
    - Design and implementation 68
    - Dielectric and magnetic material 492
    - Digital 520-521
    - EMI/EMC 334
    - Interface products 101
    - Linear 520
    - MMS products 90-92, 259
    - Manufacturing 518-523
    - Memory/logic 520-521
    - Mixed signal 520-521
    - Parametric 58, 522
    - PLL/VCO 342
    - Phase noise measuring 341
    - RF 520-521
    - RFIC 522
    - SOC 521
    - Semiconductor 520
    - Spectrum and vector analyzers 259
    - Switches 56, 97-99, 554
    - T/R module 345
    - Test software 87-88
    - VXI 93-96
    - Wireless 350
  - Test & Measurement News newsletter 602
  - Test & Measurement web site 3
  - Test Executive software 55, 86
  - Testmobiles 462, 549
  - TestSpan products and services 528
  - Thermistors 156, 307
    - Thermistor mounts and power meters 307
  - Thermocouple 156
  - Time
    - Domain
      - Analysis 41, 287-290, 295, 448
      - Capabilities 292-293
      - Upgrade 288
      - Frequency reference and 504, 508
    - Interval 132, 135-136, 589
    - Measurements, signal analyzers 227
    - Precision frequency 505
    - Signal sources 505
    - Standards 504
  - Time/Timekeeping, application notes 589
  - Time-gated measurements 45, 268
  - Timing 439, 442-448, 450, 504, 589
  - Token Ring networks, testing 401
  - Torque wrench 439
  - Tracking
    - CW microwave counters 141, 143-144
    - Generators/sources 92, 250, 254, 353
  - Trade-up program 558-559
  - Training 68, 77, 601
  - Transfer
    - Function measurements 271
    - Network analyzers 271
    - Switches 322-323
  - Transforms, application notes 590
  - Transient
    - Load simulation 165-168
    - Response time, single-output power supplies 178
  - Transistors, application notes 590
  - Transit cases 552-553
  - Transition time converter 439
  - Transmission
    - 12 Gb/s functional test 406
    - Broadcast TV 516
    - CDMA 350, 356, 379, 382-383
    - CT2-CAI 350, 382, 385
    - DCS1800 350, 382, 384
    - DECT 350, 382, 384
    - GSM 233, 350, 379, 382, 384
    - Impairment measuring set (TIMS) 400
    - Lines 348, 350-351, 356, 379-380, 382-387, 516
    - NADC-TDMA 350, 379, 382, 385, 387
    - PCS 379
    - PCS1900 350, 382, 384
    - PDC 254, 323, 350, 379, 382, 386
    - Reflection test set 250
    - Transmitter, optical 52, 476
  - Trigger/Triggering 64, 106, 117, 123, 254
  - Troubleshooting
    - Communications systems 63-64, 348, 400
    - Debugging application notes, and 590-592
    - Digital systems 63-64, 348, 400
    - Mobile phones 44
    - Mobile/Cellular radios 353-354
    - Noise/Vibration problems 535
    - Speed 353
    - Wireless networks 42-43, 348
  - Trunked radio testing 353-354
  - Trunking test solutions 348, 350-351
  - Tunable laser sources 467-468, 470-471

**U**

UHF signal generators	199
Unamplified lightwave converters	123, 477
Uninterruptable power supplies	193
Universal Counters	137-139, 194
Upgrade kits	
Antenna/RCS measurement systems	337
Network analyzers	279, 285-286, 288, 292-293
Scopes	120
Used equipment	558

**V**

VCO/PLL, signal test system/analyzer	342-343
VEE	87-88, 101, 531
VF tone generation and measurement	404
VHF switches	98-99, 554
VISA software	101
VMEbus laser interferometers	538, 540
VQT undercradle	402
VXI	
Application notes	592
Arbitrary waveform generator	218
Bus products	
2.5 Gb/s test	410
Additional literature and product notes	103
Bus connector	94
Catalog	600
Controllers	95
DWDWM test solutions	410
Data acquisition systems	530-531, 533-534
Digital	96
Embedded controllers	95
Interfaces	95
Introduction	93
M-modules	95
Mainframes	95
Mass interconnect	96
Measurement modules	95
Modules	95
Overview	93-94
PC-to-VXI interface	95
Power meter	306
Protocols	94
Relay multiplexer	96
SONET/SDH test	410
Signal analysis system	338-339
Signals development system for	340
Software	95, 531
Sources and amplifiers	96
Special purpose modules	96
Storage	95, 97
System switches	97
Systems, for real-time signal analysis	338-339
Test systems	93-97, 103, 531, 534
VXIplug&play drivers	88, 93-94
VXIbus architecture	93-94
Web site directory	94

DWDWM test solution, digital	
transmission testers	410
Data acquisition	530
Microwave synthesizer	46
Recorders	530
Stimulus subsystem	56
Synthesizer, microwave	216-218
VXI arbitrary waveform generator	218
Vector	
CAE system simulator	388
Modulation analyzers	262, 264, 388, 512
Network	
Analyzers	48, 265, 273, 275, 291, 297, 397
Measurements	272, 287-291, 293
Signal analyzers	41-42, 228-230, 259-264, 379-380, 388, 512
Voltmeter	92
Input modules, and	294
Network analyzers	294
Vehicle-mounted display system	43, 392-393
Verification tools & solutions	256, 440-441
Vibration, signal analyzers	535
Video products	
Digital video	
Signal analyzers	262-265, 512
Spectrum analyzers	264
QAM analyzer	511
Signal analyzer	512
Measurements	514, 516
TV, application notes	592
VisiTrigger technology	64
Visual	
Inspection	518
Programming language, VEE	87-88, 531
Voice	
Control, scope	118
Over IP	417
Quality testing	417
Voltage	
Application notes	592
Digital	91
Digital multimeter	145
Measurement	171-178, 180, 185
Measurement, electronic loads	165-168
Regulators, application notes	592
Vector	273, 294
Voltage-controlled oscillator, application notes	592
<b>W</b>	
W-CDMA	
Design Library	84
Signal generators	205-208, 389
Test	259
Vector signal analyzer	379
WANs	
Test solutions	400
WAN/ISDN, testers for	400
WDM	
Channel analyzer	473
Communication performance analyzer	411
Component tester	467
Test	411

Wander	
Generation and analysis	411
Test sets	411
Warranty	562
Wave analysis, application notes	593
Waveform	
Generators	56, 60, 158-161, 163, 194, 218, 535
Synthesizers and function generators	158-164
Transient analysis	535
Waveguide	
Calibration kits	299-300
Detectors	278
Output connectors source modules	226
Wavelength	
Amplitude measurement, and	473
Division Multiplexing (WDM) test	472-473
Measurement, optical analyzers	472
Meters	473
Scan	467
Weapons test solutions	424
Web enabled scopes	117
Web sites	
Agilent Technologies	3
Application notes	578
Communications test solutions	433
Power supplies	171, 175
RF & microwave test accessories	318
Semiconductor test systems	520
Service and support	68
Signal sources	198
Solar simulator	176
VEE 4.0	88
Verification solutions	43
VXIbus products	94
Wedge probe adapter	125, 460
Wide bandwidth	
CDMA signal generators, personalities	205-208
FM modulation	200-204, 210
IF detectors	295
Lightwave converters	477
Ratio measurements, power splitters	279
Receiver, MMS	252, 259
Signal analyzers	259
Windows-based PCs	
BenchLink software for	114, 154, 240, 246
NT-based PCs	101
Phase noise measurement software for	341
VEE visual programming language for	87-88, 531
Wireless	
3G network testing	43
Air interface testing	392-394
Application notes	593
Battery emulation	46
CDMA performance testing	359, 361, 379
Cellular phone test	363-367
Compliance measurements	42
Drive test systems	43, 392
Indoor measurement system	43
Mobile & base station test sets	353-378
Mobile phone	
Repair	44, 373
Tests	363-367



Mobile/Cellular radio test sets	353, 363-367
Network	
Air interface testing	392-393
Maintenance	41
Power measurements	45, 303
Protocol analyzers	50
Solutions, Bluetooth	262
Spectrum analyzer	49
Test & Measurement products	41-45, 57, 173-174, 263, 265, 316, 347-397, 508
Transmitter simulation	45
<b>Wireless communications instruments and systems</b>	41-45, 55, 205, 347-397, 508
Cellular/PCS	
Spectrum monitoring and RF coverage measurements	392
Transmitter and receiver test equipment	379, 382
Design	41
Digital microwave radio test equipment	
Functional test system	377
Instruments and systems	
Bluetooth	262, 350
Mobile/cellular radio test sets	353
Network	
Air interface testing	392-393
OEM timing modules, Additional literature and product notes	508
Overview	348-351
Pager test equipment	392, 395-396
Test equipment, summary chart	316
Test sets	55, 363, 508
<b>Wireline Communications Instruments &amp; Systems</b>	399-419
Workstations, GPIB interface cards for	101

**X**

X-ray inspection systems	518
--------------------------	-----

## Take immediate action: Find, get & buy at the Agilent Technologies web site

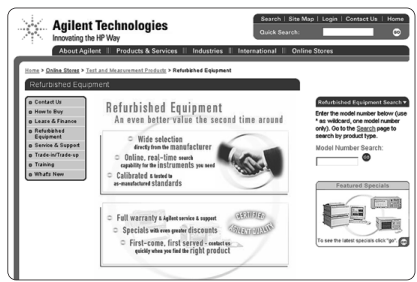
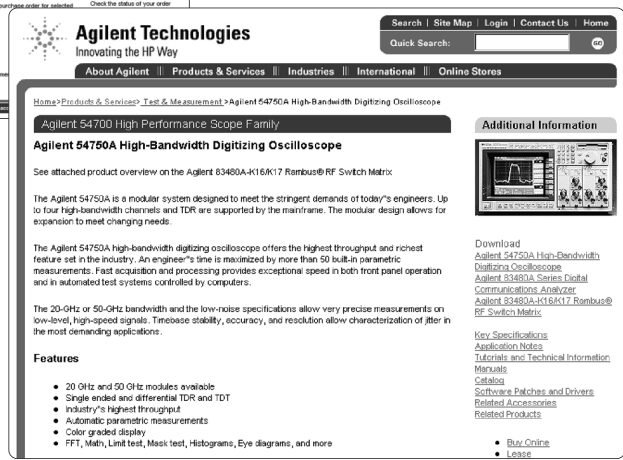

1

### Find

- Product and support information more easily with helpful navigation aids and improved web pages that make it easier to access application notes, product overviews, technical details, frequently asked questions, manuals, software, news releases, education course descriptions and schedules, and much more.

### Get

- Updated comparison data and evaluation guides/tools that facilitate product selections
- Helpful application notes, downloadable interactive application notes, tutorials, online models, and other learning and problem-solving material
- Quick access to customer support services
- Information on recommended replacements for discontinued products
- Information in your local language\*
- The latest information on the status of your Agilent test and measurement order

### Buy

- Selected Agilent products—including scopes, logic analyzers, EDA software, multimeters, data acquisition products, signal sources, counters, power supplies, and more\*
- Refurbished instruments\*
- Accessories\*
- Replacement parts\*

For more information on the test and measurement features, resources, and services available on Agilent's web site, see page 3.

Use our online test and measurement resources and services often!  
[www.agilent.com/find/tmc](http://www.agilent.com/find/tmc)

\*Availability of this feature may be limited; an expansion program is ongoing. Online purchases require a credit card.

For best results, view the Agilent web site with Microsoft's Internet Explorer browser.

# Product Number Index

26

Model Index 01650-63203 – 16453A

## 0

01650-63203 Termination Adapter	461
08645-61116 Service Kit	224

## 1

10020A Resistor Divider Probe Kit	131
10070 Passive Divider Probe Family	124
10070C/73B/74C/76A Passive Divider Probes	124
10072A/75A/450A SMT Probe Accessory Kits	128
10076A High-Voltage Probe	131
10077A Accessory Kit for 10076A	131
10400B Passive Probe Family	125
10467-68701 IC Clips	128
10702A Linear Interferometer	539
10705A Single-Beam Interferometer	539
10706A/B Plane-Mirror Interferometers	539
10715A Differential Interferometer	539
10716A High-Resolution Interferometer	539
10719A/21A One- and Two-Axis Differential Interferometers	539-540
10735A/36A Three-Axis Interferometers	539
10737/L/R Compact Three-Axis Interferometers	539
10833A/B/C/D Cables/Accessories	101, 245, 554
10834A Adapter	554
10885A PC-Compatible Laser Axis Board	540
10886A PC Compensation Board	540
10887B PC Calibrator Board w/5592A Software	540
10887P Programmable PC Calibrator Board	540
10889B PC Servo-Axis Board	540
10895A VMEbus Laser Interferometer	540
10896B VMEbus Compensation Board	539-540
10897B High-Resolution VME Laser Axis Board	538, 540
11000 Series Connectors/Adapters	555-556
11053A Low Thermal Lug-Lug Jumper Set	152-153
11058A Low Thermal Banana-Banana Jumper Set	152-153
11059A Kelvin Probe Set	152
11060A Surface Mount Device Test Probe	152
11062A Kelvin Clip Set	152
11174A Low-Thermal Lug-Banana Jumper Set	152-153
1141A 200 MHz Differential Probe	129
1142A Power Supply for 1144A & 1145A	130
1143A Power Offset & Power Module for 54701A	130
1144A 800 MHz Active Probe	130
1145A 2-Channel, 750 MHz Active Probe	130
1146A Oscilloscope ac/dc Current Probe	131
11500I/J/K/L Test Port Cables	301
1152A 2.5-GHz, 0.6-pF Active Probe	130
11524A/25A/33A/34A APC-7 Adapters	556
1153A/54A Differential Probes	61, 129
1155A Low-Mass Active Probe	130
11570A Accessory Kit for 8508A and 70138A	294

11581A/82A/83A/C Attenuator Sets	327
1159A 1-GHz Differential Probe	61, 129
1160A Miniature Passive Probe Family	126
11636A/B Power Dividers	279-280
11644A (K/P/Q/R/U/V/W/X) Electronic Calibration Modules	300
11667A/B/C Power Splitters	279-280, 439
11679A/B Detector Extension Cables	279-280
11691/92D Standard Connectors	330
11693A Microwave Limiter	254
11694A 75-W Matching Transformer	254
11713A Attenuator/Switch Driver	318
11715A AM/FM Test Source	258
11716A/C Attenuator Interconnect Kits	325
11721A Frequency Doubler	213
11722A/92A Sensor Modules	256
11757B Multipath Fading Simulator/Signature Test Set	352
11758V Digital Radio Test System	352
11770A Link Measurement Personality	242, 245, 352
11792A/3A Microwave Converters	256
1180C/81B/82B Testmobile Carts	549, 551
11807A/E Radio Test Software	353-355
11807B Cell Site Test Software	356, 358
11812A Verification Kit	256
11817A//27A/37A Retrofit Kits	160
1184A Testmobile	462
11850C 50- $\Omega$ 3-Way Power Splitter	282, 302
11851B Test Port Cable	301
11852B 50- $\Omega$ /75- $\Omega$ Minimum Loss Pad	279-280, 302
11853A 50- $\Omega$ Type-N Accessory Kit	286, 302
11854A 50- $\Omega$ BNC Accessory Kit	286, 302
11855A 75- $\Omega$ Type-N Accessory Kit	286, 302
11856A 75- $\Omega$ BNC Accessory Kit	286, 302
11857B/D/F Test Port Cables	301
11867A/693A RF Limiters	254
11887A Type-N/3.5-mm Adapter Kit	302
11896A Polarization Controller	471
11906A/B/C/D Adapter Kits	286, 302
11930A/B Power Limiters	302
11970 Series Harmonic Mixer	247
11974 Series Preselected Millimeter Mixers	247
11982A Amplified Lightwave Converter	123, 241, 477
1250 Series Connectors/Adapters	439, 555-556
14565A Device Characterization Software	46, 173
1494-0015 Slide Rail Kit	548, 550
1494-0058/59/60 Slide Kits	550
1494-0059 Non-Tilting Rack Slide Kit	224
1494-0061/64 End Brackets	550
1494-0063 Tilting Rack Slide Kit	224
15104A Pulse Adder/Splitter	433
15115A Splitter-Inverter	433
15116A Pulse Inverter	433
15432B/33B/34B/35A/35B/38B Transition Time Converters	433, 439
15439A Multichannel Accessory Kits	439

15443A Matched Cable Pair	407
1600-1424 Tie-Down Clip for Support Shelf	548, 550
16005B/C/D Kelvin Clip Leads	499
16006A Pin-Type Probe Lead	499
16007A/B Alligator Clip Leads	499
16008B Resistivity Cell	482, 500
16034EG/H/LT SMD/Chip Component Test Fixtures	484, 490, 494, 498
16043A/B 3-Terminal SMD Test Fixtures	484, 490
16044A/B Kelvin Contact SMD Test Fixtures	484, 490, 498
16047A/C/D/E Contact Lead Component Test Fixtures	484, 490, 494
16048A/B/C/D/E/G/H Test Leads	484, 490, 498
16060A Transformer Test Fixture	484, 494
16064B LED Display/Trigger Box	494, 499-500
16065A External Voltage Bias w/Safety Cover (<200 vdc)	484
16065C External Bias Adapter (<40 vdc)	484, 494
16085B Four-Terminal Pair to 7mm Adapter	484
16087A Module Selector	525
16089A/B/C/D/E Kelvin Clip Leads	484
16092A RF Spring Clip: Axial, Radial & SMD	484, 487-488
16093A/B RF Binding Posts	484
16094A RF Probe Tip/Adapter	484, 487-488
16095A LF Impedance Probe	484
16099A Test Fixture Adapter	484
16117B/C Low-Noise Test Leads	500
16118A Tweezer Test Fixture	500
16143B Mating Cable	499
16190A/B Performance Test Kits	486-488, 497
16191A Side Electrode SMD Test Fixture	484, 486-488, 497
16192A Parallel Electrode SMD Test Fixture	484, 486-488
16193A Small Side Electrode SMD Test Fixture	484, 486, 497
16194A High Temperature Test Fixture	484, 487-488, 497
16195B 7mm Coaxial Calibration Kit	487-488, 497
16196A/B/C Parallel Electrode SMA/SMD Test Fixtures	484, 486-488, 497
16197A Bottom Electrode SMA Test Fixture	47, 486-488, 497
16200B External dc Bias Adapter	484, 487-488
16314A 4-Terminal Balun (50- $\Omega$ Bal. to 50- $\Omega$ Unbal.)	484
16315A/16A/17A One-Terminal (BND) Baluns	484
16334A SMD/Chip Tweezer Test Fixture	484, 494, 498
16338A Test Lead Set	499
16339A Component Test Fixture	500
16451B Dielectric Material Test Fixture	482-484, 490, 493
16452A Liquid Test Fixture	482-483, 493
16453A Dielectric Material Test Fixture	486-488, 492



54657A GPIB Measurement/Storage Module	114
54695B RS-232/Parallel Measurement/ Storage Module	114
54701A 2.5-GHz, 0.6-pF Active Probe	130
54720D Oscilloscope	124
54750A Communication Analyzer	53, 121, 475
54750A Series High-Bandwidth Digitizing Oscilloscopes	107, 124
5475XA Communication Analyzer Module	122
54800 Series Infiniium Oscilloscopes	107, 116-120
5517A/B/C/D Laser Heads	539
5527B Laser Interferometer Positioning System	538
5529A Dynamic Calibrator	541
57400 Series EMC Analyzers	334
58000 Series Time and Frequency Reference Distribution Modules	348
59306A Relay Actuator	554
59307A Dual VHF Switch	554
59510A Output Isolation, Relay Accessory	186
59511A Output Isolation, Polarity Reversal Accessory	186
5DX Series II X-Ray Systems	350-351, 518
5DX X-Ray Inspection Station	350-351

## 6

6010A/11A/12B/15A/23A/28A Analog Power Supplies	185
6030A/31A/32A/33A/35A/38A System Power Supplies	185
60501B/02B/03B/04B/07B/51A/60B/63B dc Electronic Load Family	165
6541A/42A/43A/44A/45A/51A/52A/53A/ 54A/55A/71A/72A/73A/74A/75A Single-Output Power Supplies	181-183
66000A Modular Power System	172
66001A Modular Power System Keyboard	171-172
66101A/02A/03A/04A/05A/06A dc Power Modules	171-172
6611C/12C/13C/14C Precision Measurement Single-Output System Power Supplies	178
6621A/22A Dual-Output Power Supplies	179
6623A Triple-Output Power Supply	179
6624A/27A Quad-Output Power Supplies	179
6625A/28A Precision Dual-Output Power Supplies	179
6626A/29A Precision Quad-Output Power Supplies	179
66300 Series Mobile Communications dc Sources	46, 173-174, 348, 350-351
6631B/32B/33B/34B Precision Measurement Single-Output Power Supplies	180
66319B/D Dual-Output dc Power Source	46, 173
66321B/D Single-Output dc Power Source	46, 173
66332A Dynamic Measurement Single-Output Power Supply	177

6641A/42A/43A/44A/45A/51A/52A/53A/ 54A/55A/6671A/72A/73A/74A/75A6680A/ 81A/82A/83A/84A Single-Output System Power Supplies	181-184, 355
6800A/B Series ac Power Source/ Analyzers	60, 192-193
6843A Regulatory Test Solution	192-193

## 7

70000 Modular Measurement System	90, 203, 423
70001A System Mainframe	91
70004A Color Display and Mainframe	91
70100A MMS Power Meter	91, 306
70110A Digital Multimeter	91
70120A Universal Counter	91
70205A Graphics Display	91
70310A Precision Frequency Reference	92
70330A Pulse Generator	92
70422A Downconverter Module	343
70427A Microwave Downconverter Module	91
70428A Microwave Source	91
70611A Attenuator/Switch Driver	90, 318
70620B/21A Preamplifier	92
70703A Digitizing Oscilloscope	91
70875A Noise Figure Measurement Personality	251
70911A Ultra-Wide-Bandwidth IF Module	252
71000T Series Wide-Bandwidth Signal Analyzer Systems	259
71100C/P/200C/P/209A/P/210C/P Spectrum Analyzers	91-92, 251
71450B/51B/52B Optical Spectrum Analyzers	92
71500A Microwave Transition Analyzer	91
71501C Jitter and Eye-Diagram Analyzer	92
71603B Gigabit Error Performance Analyzer	92
71612B Series 12-Gb/s Tester	406
71707A Microwave Downconverter	91, 343
71708A Microwave Source	91
71910A/P Wide-Bandwidth Receiver	92, 252
75000 Series B/C VXI Data Acquisition Systems	93-94, 97, 534, 539
772/3/5/6/7/8/9D Dual Directional Couplers	330
7731A/32A/33A/34A/35A/36A/37A Series EIA Unit Filler Panels	551
79000 FCT System	518

## 8

81000AI/FI/GI/KI/NI/PI/SI/VI/WI Connector Interfaces	468, 471
81023A/25A/26A/32A/33A/34A/35A Power Sensor Modules	470
8110A 150-MHz Pulse/ Pattern Generator	432, 434-435, 437
81101A 50-MHz Pulse Generator	432, 434-435

81103A Output Module	437
81104A 80-MHz Pulse/ Pattern Generator	432, 434-435
81106A External Clock Module	437
81107A Deskew Module	437
81110A 165-MHz/830-MHz Pulse/ Pattern Generator	432, 434-435
81130A 400-MHz/660-MHz 1.32 Gbs/ Pulse/Data Generator	432, 434-435
8114A High-Power Pulse Generator	432, 438
8120 Series Connectors/ Adapters	555-556
8120-1575C Female-Male Power Cable	551
8120-3448/49 GPIB Cables	554
8120-8160 Female-Male Power Cable	551
81200 Data Generator/Analyzer Platform	430-431
81250 ParBERT Parallel Bit Error Ratio Tester	51, 407, 412
8133A Pulse Generator	432, 439
8153A/63A Lightwave Multimeter Mainframe	470
8156A Attenuator	471
81610A/11A/12A/13A/14A Return Loss Modules	470
8163A Lightwave Multimeter Mainframe	468-469
8164A Lightwave Measurement System	467
81650A/51A/52A/53A/54A Source Modules, 0 dBm	470
81655A/56A/57A Source Modules, 13 dBm	470
8166A Lightwave Multichannel System Mainframe	468-469
8167B Tunable Laser Source	468, 471
81680A/82A/89A Tunable Laser Modules	467
81682A Tunable Laser Module	467
81689A Compact Tunable Source Module	470
8169A Polarization Controller	471
81700 Series 200 Remote Fiber Test and Management System	413
82341C/D/E GPIB Interfaces	95, 101
82345B PC Windows 3.1 Automation Kit	88
82345F/G VEE PC Automation Kits	87, 101
82346B/C BASIC PC Automation Kits	87, 101
82350 GPIB Interface for PCI Bus	101
82351F/G VEE PC Automation Kits	87, 101
82353G VEE OneLab PC Automation Kit	101
82356C BASIC PC Automation Kit	87, 101
83000 Series VLSI Production Test Systems	520
83006A/17A/18A/20A Microwave System Amplifiers	317
83036C Broadband Directional Detector	328
83050A Series 50-GHz Amplifiers	249, 317
83051A 50-GHz Preamplifier	317
83201B Dual-Mode Cellular Adapter	355
83206A TDMA Cellular Adapter	354-355
83217A Mobile Station Test Software	368-371
83220A/E DCS/PCS Test Sets	375-376
83430A Lightwave Digital Source	477
83433A/34A 10-Gb/s Lightwave Transmitters	52, 476



83440 Series Unamplified Lightwave Converters	123, 477	85046A/B/47A S-Parameter Test Sets	268-269, 288-289	85671A Phase Noise Measurement Utility	247, 249, 254
83446A Lightwave Clock/Data Receiver	477	85051B/53B/55A/57B Mechanical Verification Kits	300	85672A Spurious Response Measurement Utility	247, 254, 387
8347A RF Amplifier	315	85060 Series Electronic Calibration Modules	291, 300	85700A/02A/04A/05A Blank Memory Cards	245, 249
83480A Communication Analyzer	53, 121	85070C High-Temperature Dielectric Probe Kit	491	8571A/72A/73B/74B EMI Receivers	245
83484A Communication Analyzer Module	122, 475	85071C Materials Measurement Software	491	85710A Digital Radio Measurement Personality	247, 249
8348A/49B Microwave Amplifiers	316	8508A Vector Voltmeter	273, 294	85713A Digital Radio Measurement Personality	242, 245
8349xA Communication Analyzer Module	122	85081B High-Impedance Input Module	294	85714A Scalar Measurement Personality	241, 245, 250
83550 Series Millimeter-Wave Source Modules	199, 225-226	85082A Input Module	294	85715B GSM Measurement Personality	242, 245, 384
8360 Series Synthesized Swept Signal & CW Generators	199, 221-222, 225	8509B Polarization Analyzer	474	85718B NADC-TDMA Measurement Personality	242, 245, 385
83600L Series Synthesized Swept CW Generators	199, 221-222, 225	85091B/92B/93B/96B Wavelength Mechanical Calibration Kits	300	85719A Noise Figure Measurement Personality	241, 245, 250
83600B Series Synthesized Sweepers	199, 221-222, 225	85097A ECAL PC Interface Kit	291, 300	85720/C PDC Measurement Personality	242, 245, 386
83621B/31B/51B Network Analyzer Sources	296	85098B Wavelength Mechanical Calibration Kit	300	85721A Cable TV Measurement Personality Software	241, 514
83711B/12B Synthesized CW Generators	199, 214-215	8510 Series Microwave Network Analyzers	273, 295	85722B dcS1800 Measurement Personality	242, 245
83730 Series Signal Generators	199, 214-215	8510C Microwave Vector Network Analyzer	295	85723A DECT Measurement Personality	242, 245, 384
83750A/B Series Synthesized Microwave Sweepers	219-220, 225	8510XF Network Analyzer	297	85724A Broadcast TV Measurement Personality	241, 245, 516
84000 Series RFIC Test Systems	348, 350-351, 522	85105A Network Analyzer Millimeter-Wave Controller	296	85725C CDMA Measurement Personality	242, 245, 383
84105EM Design Development System	334	85106D Millimeter-Wave Network Analyzer System	297	85726A/B PHS Measurement Personality	242, 245, 348, 386
84115EM Pre-Production Evaluation System	334	85108A/L Pulsed RF Network Analyzers	298	85727A GSM Multi-Band Measurement Personality	242, 245, 384
8444A Option 059 Tracking Generator	254	8511A/B Frequency Converters	296, 337	8590 E-Series Spectrum Analyzers	239-240, 243-244, 250, 348, 350-351, 516
8447 Series RF Amplifiers	254, 315-316	85110A/L Network Analyzer Pulse Test Sets	296	8590L/92L/93/94/94L/8591/93/94/95/96E Spectrum Analyzers	240, 244-245
8449B Microwave Preamplifier	254, 316	85120A MMIC Test System	345	85901A Portable ac Power Source	249, 254, 514
8471D/E Planar-Doped Barrier Detectors	328	85121A Payload Test System (PTS)	424	85902A Burst Carrier Trigger	249, 254
8472B/73B/C Low-Barrier Schottky Diode Detectors	328	85122A Precision Modeling System	85	85905A 75-W Preamplifier	514
8473D Planar-Doped Barrier Detector	328	85130B/C/D/E/F/G Series Test Port Cables	301	8591C Cable TV Analyzer	513-514
8474B/C/D/E High-Performance Planar-Doped Barrier Detectors	328	8514B/15A Network Analyzer Test Sets	296	8591E/93E/94E/95E/96E Spectrum Analyzers	240, 243
8477A Power Meter Calibrator	307	85161B Measurement Automation Software	295	8592L/4L Spectrum Analyzer	240
8478B Temperature-Compensated Thermistor Mount	307	8517B Network Analyzer Test Set	296	85921B Cable TV Data Management Software	514
8480 Series Power Sensors	309	85180A High Frequency Structure Simulator	84	8594Q DVB-C QAM Analyzer	510-511
8490D/91A/B/C/93A/B/C Series Fixed Attenuators	327	85205A/07A RF Bridges	254	8595E Spectrum Analyzer	355
84904/06/07K/L Series High-Performance Coaxial Attenuators	324	8530A Microwave Receiver	337	85960B CaLan 2010B SLM Plus	515
8493A Series Attenuators	439	85301B/C Antenna/RCS Measurement Systems	337	85961B CaLan 3010B Sweep/SLM Plus	515
8494 Series Step Attenuators	325, 326	85309A LO/IF Distribution Unit	337	85962A CaLan 3010R Sweep/Ingress Analyzer	515
84940A Attenuator/Switch Driver Expansion Card	318	85310A Distributed Frequency Downconverter Unit	337	85963A CaLan 3010H Sweep/Ingress Analyzer	515
84941A Distribution Expansion Card	318	85320A/B Antenna Test Mixers	337	86030A Lightwave Component Analyzer	54, 478
8495/96 Series Step Attenuators	326	85325A mm-Wave Subsystem	337	86037C CD Test Solution	474
8498A High-Power Attenuator	327	85326A mm-Wave Interface Kit	337	86100A Infiniium DCA Wide-Bandwidth Oscilloscope	53, 107, 121-122, 475
85000 Series Calibration Kits	286, 300	85330A Multiple Channel Controller	337		
85022A System Cable Kit	279-280	85331/32A Microwave Switches	337		
85024A High-Frequency Probe	302	85370A Antenna Position Encoder	337		
85025/25A/B/D/E Series Detectors	277, 280	85407A S-Parameter Test Set	289		
85025C/26C Detector Adapters	280	8560 EC-Series Spectrum Analyzers	249		
85027 Series Directional Bridges	278, 280	8560E/61E Series Spectrum Analyzers	246-247, 348-249, 350-351, 387		
85029B Mechanical Verification Kit	300	8562E RF Spectrum Analyzer	247, 249, 387		
85037A/B Series Precision Detectors	277, 280	85620A Mass Memory Module	247, 249		
85043C System Rack	295	85629B Test & Adjustment Module	247, 249		
		8563E Microwave Spectrum Analyzer	247, 249		
		85630A Scalar Transmission/Reflection Test Set	250		
		8564/65E Millimeter Spectrum Analyzers	247, 249-250, 254		

86100A Series Communication Analyzer Modules	122
86120C Multi-Wavelength Meter	473
86121A WDM Channel Analyzer	473
86130A BitAnalyzer	53, 121, 406
86140A/B Family Optical Spectrum Analyzers	53-54, 472, 478
86200B/01B Scalar Detectors	285-286
86205A/07A RF Bridges	254, 286, 302
86211A Type-F Accessory Kit	286
86224B IBASIC Upgrade Kit	286
86383C Upgrade Kit for 8757D	280
8643A/44B High-Performance RF Signal Generators	198, 210, 348, 350-351, 355
8645A Agile Signal Generator	199, 223-224
8648A Option 1EP Signal Generator for Pager Test	200-201, 348, 350-351, 395
8648A/B/C/D Analog RF Signal Generators	198, 200-201
8656B/57A/B Economy RF Signal Generators	343
8662A/63A/64A/65A/B High-Performance RF Signal Generators	198, 210-213, 343-344
8690 Series 10 Mobile Phone Manufacturing Test Sets	365
87050E Multiport Test Set	284, 286
87075C Multiport Test Set	284, 286
87104/106A/B/C Multiport Coaxial Switches	322-323
8711/12/13/14C/14E RF Economy Network Analyzers	348
8712/14/ET/ES RF Network Analyzers	273, 283, 285-286
87130A Attenuator/Switch Driver	318
8719 Upgrade Kit for 8719D	292
8719ES/ET Microwave Network Analyzers	291, 293
8720 Vector Network Analyzer	348, 350-351
8720/22/ET/ES Microwave Network Analyzers	273
8720DU Upgrade Kit for 8720D	292
8720E Family Upgrade Kits	292
8720ES/ET Microwave Network Analyzers	291, 293
8722DU Upgrade Kit for 8722D	292
8722ES/ET Microwave Network Analyzers	291, 293
87222C/E Transfer Switches	322-323
87227C LAN Upgrade Kit	286
872341D/82350A High-Performance GPIB Cards w/ Buffering	101
87300 Series Directional Couplers	330
87405A Preamplifier	250, 254, 317
87406B/606B Coaxial Matrix Multiport Switches	322-323
87415A/21A/22A Microwave System Amplifiers	317
87421A/42A Power Supplies	317
87511A/B S-Parameter Test Sets	266-267, 270
87512A/B Transmission/Reflection Test Kits	266-270
8752/53 Vector Network Analyzers	348, 350-351

8753DU Option 000 Processor Upgrade for 8753D	288
8753ES/ET RF Network Analyzers	273, 287-288, 290
8757 System Accessories	277-278
8757D Network Analyzer	276, 280
8757D Option 002, Power Calibrator	278
8757D/E Scalar Network Analyzers	276, 280
8757XC Coaxial Scalar Systems	280
8760 Series Coaxial Switches	320-323
8900C/D Peak Power Meters	306
8901B Modulation Analyzer	257-258, 348
8902A Measuring Receiver	255-256
8903B Audio Analyzer	348, 390-391
8904A Function Synthesizer	158-160
89104A Vector Signal Analyzer	252
8920A/B/DT RF Communications Test Sets	348, 350-351, 353-355
8921A Cell Site Test Set	356, 358
8921A Options 500/502/503/600/602/603, TDMA/CDMA Cell Site Test Systems	357
8922M/P GSM Mobile Station Manufacturing Test Sets	350-351, 375-376
8924E CDMA Mobile Station Service Test Set	350-351, 370-371
8935 CDMA/TDMA Base Station Test Set	348, 350-351, 359
89400 Series Vector Signal Analyzers	262-263, 265, 348, 350-351, 388, 510, 512
89410A dc to 10 MHz Vector Signal Analyzer	262-263, 265, 388, 512
89411A 21.4 MHz Downconverter	262-263, 265, 388
89431A RF Downconverter	262-263, 265
89441A dc to 2.65 GHz Vector Signal Analyzer	262-264, 265, 388, 512
89441V USB/QAM Signal Analyzer	265
89441V VSB/QAM Signal Analyzer	262-263, 512
89450A DMCA Radio Test Application Personality	262-265
89451A Radio Test Personality	262-263, 265, 388
8950E Series Spectrum Analyzers	239
8960 Series 10 Mobile Phone Manufacturing Test Sets	55, 363-364, 366-367
89600 Series Vector Signal Analyzers	41, 260, 350-351, 425
89600A Vector Signal Analyzer	422
89601A Vector Signal Analysis Software	260
89606A Input Calibration Module (VXI)	260
89610A Vector Signal Analyzer	41, 260
89640A RF VSA	260
897B Noise Figure Meter	313
8970B Noise Figure Meter	314
8970S/V Noise Figure System	314
8971C Noise Figure Test Set	314

9211-1296/2662 Transit Cases	203, 207, 224
92199B/E Power Strips	551
92284A Centronics Cable	554
93000 SOC Series IC Test Systems	520
94000 Mixed Signal LSI Test System	348
94000 Series Mixed Signal IC Test Systems	520
94000IP CMOS Imager Test System	520
9420A Interface Connection Assembly	96
9421A Connector Block, Cable Assembly	96
95000 Series High-Speed Memory Test Systems	57, 520-522
9663A High-Performance RF Signal Generator	211-213

## A

AccessFiber 3.0 Fiber Network Management System	413
Advanced Design System	59, 84-85, 350-351
Advisor Testers	402
aurora Series Testers	408

## B

B4600B System Performance Analysis Tool Set	454
B4601B Serial Analysis Tool Set	454
B4605B Tool Development Kit	454
B4620B Source Correlation Tool Set	454
B4640B Data Communications Tool Set	454
BV3000 Automated Optical Inspection Systems	350-351, 518
BestLink/81200 Simulation Data Link	430
BitAnalyzer BER Tester	53, 121, 405

## C

C1405B DIN Keyboard	245
C2642A HP DeskJet 400 Monochrome/Color Printer	245
C2655A HP DeskJet 340 Portable Monochrome/Color Printer	245
C2788B/C Computer Rail Kits	550
C2790AC 30-lb. Steel Ballast	550
C2932A RS-232 Cable	245
C2950/50A IEEE 1284-Compliant A-B Parallel Cables	245, 554
C2951 IEEE 1284-Compliant Cable 3 m (9.9 ft.)	554
C4549A/62A/89A HP DeskJet 680C Color Printers	245
CellOpt	396

## D

DCA	53, 121
DDCC-37001 Synchro/Resolver Simulator and Indicator	96
DWDM test solution	410
DataPrint	396
DesignGuide EDA Tools	59, 84

## E

E1300A//01A 75000 Mainframes	95
E1326B 5-Digit Multimeter	95
E1328A 4-Ch. D/A Converter	96
E1330B Quad 8-bit Digital I/O	96
E1332A 4-Ch. Counter/Totalizer	95
E1333A 3-Ch. Universal Counter	95
E1339A 72-Ch. Open-Collector Dig Out/Relay Driver	96
E1343A/45A/46A/47A/51A/52A/53A/55A/56A/57A/58A Multiplexers	96
E1361A/64A Matrix Switches	96
E1366A/67A RF MUX	96
E1368A Microwave Switch	96, 318
E1369A Microwave Switch Driver	96, 318
E1370A Microwave Switch/Step Attenuator Driver	96, 318
E1371A Data Over Cable Service Interface Specification (DOCSIS)	422
E1406A 75000 Controller	95
E1410A/12A 6.5-Digit Multimeter	95
E1411B 5-Digit Multimeter	95
E1413C 64-Ch. Scanning A/D	95
E1415A Algorithmic Closed-Loop Controller	95
E1416A VXI Power Meter	306
E1418A 8/16-Ch. D/A Converter	96
E1419A Multi-Function Measurement and Control	95
E1420B High-Performance Universal Counter	95
E1421B 75000 Mainframe	95
E1426A 500-MHz Digitizing Oscilloscope	95
E1428A 1-GSa/s Digitizing Oscilloscope	95
E1429A/B 20-MSa/s Digitizer	95
E1430A 10-MSa/s A/D	95
E1431A 8-Ch., 51.2-kHz Digitizer	95
E1432A 16-Ch., 51.2-kHz Digitizer	95, 532
E1433A 8-Ch., 196-kSa/s Digitizer	95
E1434A 4-Ch., 65-kSa/s Arbitrary Source	95, 532
E1437A-20 MSa/s Digitizer	95
E1438A 100-MSa/s ADC (VXI)	260
E1440A Synthesized Function/Sweep Generator	96
E1441A Arbitrary Waveform Generator	96
E1442A Remote Channel DAC Unit	533
E1442A/63A Matrix Switches	96
E1444A/60A/76A MUX Switches	96
E1445A Arbitrary Function Generator	96
E1452A Pattern I/O Module	96

E1458A 96-Ch. Digital I/O	96
E1459A 64-Ch. Isolated Dig Input/Interrupt	96
E1465A/66A/67A/68A/69A General Purpose Switches	96
E1470A RF Multiplexer	96
E1472A/73A/74A/75A RF Multiplexers	96
E1482B VXIbus-to-MXIbus Extender	95
E1485C Digital Signal Processor	95
E1488B 8-Channel Digitizer	532
E1489C EISA/ISA-to-MXI Interface	95
E1498A Embedded Controller	95
E1529/29A Remote Strain Conditioning Units	426, 533
E1539 Remote Channel Signal Conditioning Plugon	533
E1562D/E/F 75000 VXI Data Disk/DAT/SCSI-2 Interface Modules	95
E1563A/64A Digitizers	95
E1586A Terminal Panel	533
E1710A Angular Encoder System	542-543
E1711A Sensor Head	542-543
E1712A Scale	542-543
E1713A Scale Servo Axis Board	542-543
E1714A Master Arm Assembly	542-543
E1721A Non-Contact Push Pin (NCCP) Sensor	542
E1723A DSP Servo-Axis Board	543
E1725C/40A Time Interval Analyzers	132-136
E1750A/52A Distribution Amplifiers	96
E1960A/61A 8960 Series 10 GSM Mobile Test Applications	363-364, 367
E1962A 8960 Series 10 IS-2000 Mobile Test Application	363, 365, 367
E1964A 8960 Series 10 GPRS Mobile Test Application	363-364, 367
E2011E Text Exec SL	55, 86
E2050A/B LAN/GPIB Gateways	95, 157, 102
E2060D HTBasic for Windows	89
E2070C/71C71D/74B/75A/91E/94E GPIB Interfaces	101
E2110C VEE for Series 300	88
E2111E VEE 4.0 for HP-UX Series 700	88
E2111F VEE 5.0 for HP-UX	87
E21117E VEE Site License	88
E2120C/D/E VEE for Windows	87-88, 95
E2122D VEE 3.1 for Windows 3.1 for Education	88
E2122E VEE4.1 for Windows 95/NT for Education	88
E2171B/89A GSM Cellular Phone Functional Test Platforms	377
E2259A Double-Wide Breadboard M-Module	95
E2261A Quad RS-232 Interface M-Module	95
E2270A 16-Ch. Form A Switch M-Module	95
E2271A 4x4 Matrix Switch M-Module	95
E2272A Dual 8-to-1 Relay Multiplexer M-Module	95
E2273A 8-Ch. Form C Switch M-Module	95
E2290A 16-bit Digital I/O M-Module	95
E2307A Type K Thermocouple Bead Temperature Probe	152-153
E2308A Thermistor Temperature Probe	152-153

E2609A Infiniium Rackmount Kit	120
E2610A Infiniium Keyboard	120
E2611A Infiniium Clip-on Trackball	120
E2612A Infiniium TouchPad	120
E2613A/B14A/15A/B16A/43A/44B HP Wedge Probe Adapters	128
E2617A Infiniium Oscilloscope Transit Case	120
E2625A Communication Mask Test Kit	120
E2633A Infiniium Oscilloscope Performance Upgrade	120
E2652A & E2653A Fine Pitch Probing Kits	127
E2749A Fiber Channel Data I/O Module	95
E2920 PCI Series	440
E2925B 32-bit, 33-MHz PCI Exerciser and Analyzer Card	440-441
E2926B 32/64 bit, 33-MHz PCI Exerciser and Analyzer Card	440-441
E2928A 32/64 Bit, 33/66 MHz PCI Exerciser and Analyzer Card	440-441
E2929A PCI-X Exerciser/Analyzer	62, 440
E2940A Compact PCI Exerciser and Analyzer Card	440-441
E2977A Design Verification Test Library	62, 440
E3238 Signals Development System	425
E3238S Signals Development System	340
E3242A Breakout Box Accessory Interfaces Accelerometers to E1432A/33A VXI Digitizers	95
E3243A Breakout Box Accessory Interfaces Microphones to E1432A/33A VXI Digitizers	95
E3249B HP 75000 SCSI System Disk/Hard Drive/DAT Tape	95
E34171A DMM Terminal Connector	153
E3604A/41A/42A/3A/44A/45A Single-Output Power Supplies	187
E3610A/11A/12A Single-Output, Dual-Range Power Supplies	191
E3614A/15A/16A/17A/32A/33A/34A Single-Output Power Supplies	189, 191
E3619A Power Supply Test Lead	187
E3620A Dual-Output Power Supply	190
E3630A/31A Triple-Output Power Supplies	190
E3631A Triple-Output Power Supply	189
E3640A Series Dual-Output Power Supplies	62, 187-188
E3660B/B-AW3/B-AW5 Rack Cabinets	546-547, 550
E3661B-AXH Bare Rack	546-547, 550
E3661B/B-AW3/B-AW5 Rack Cabinets	546-547, 550
E3662B-AXH Bare Rack	550
E3662B/B-AW3/B-AW5 Rack Cabinets	546-547, 550
E3663AC/64AC/65AC Rail Kits	550
E3668B Feedthrough Panel	551
E3669B BNC-BNC Panel	551
E3722A Hinged Autoface Connector Assembly	96
E4028C HP75000 SCSI Disk/Hard Drive/Floppy	95

E4310A Optical Time Domain Reflectometer (OTDR)	413, 415-416	E4832A 660-MHz Generator/Analyzer Module	407	E6232A/33A VXI Pentium PC Controller WIN 95/NT	95
E4311A/12A/13A/14A/15A/16A/17A/18A/19A 1310/1550nm Single-Mode Modules	415	E4835A Two Differential Analyzer Front-Ends, 660 Msa	407	E6237A VXI Pentium PC Controller LynxOS	95
E4320A Virtual-Remote and Analysis Software	415	E4837A Differential Analyzer, 660 Msa/s	431	E6271A MPEGscope ATM Test Application	510
E4350B/51B Solar Array Simulators	176	E4838A Differential Generator Front-End, 660 MHz, Variable Slopes	407, 431	E6277A MPEGscope Plus	510
E4356A Telecommunications dc Power Supply	173-175	E4839A Text Fixture for the 81200 Series	430-431	E6323A E1 Test Advisor Undercradle	409
E4400B/20B/21B/22B ESG-A Series Analog RF Signal Generators	198, 202, 204	E4840A Small Mainframe	431	E6325A T1 Test Advisor	409
E4402/4/5/7B BAH GSM Measurement Personalities	381	E4841A 660-MHz Data Generator/Analyzer Module	430-431	E6349A E1 Test Advisor	409
E4402/4/5/7B Option B74 RF and Digital Communications Hardware	381	E4843A Differential Generator Front-End, 660 MHz	407, 431	E6380A cdma2000 Tester	41, 359
E4402/4/5/7B Option BAC cdmaOne Measurement Personalities	381	E4846A Dual Generator, 2000 Mb/s	431	E6380A Option 200, cdma2000 Tester	41, 359
E4403B 9 kHz-3.0 GHz Spectrum Analyzer	229, 237	E4847A Dual High-Impedance Analyzer, 330 MSA/s	431	E6392A/B GSM Mobile Station Test Sets	44, 350-351, 373
E4406A VSA Transmitter Tester	42, 350-351, 379-380	E4848A/B Expander Mainframes	431	E6432A VXI Microwave Synthesizer	46, 199, 216-218, 422-423
E4406A Option 202 VSA Transmitter Tester	42, 379	E4849A/C Mainframes	431	E6500A VXI Tuner	96
E4408B 9 kHz-26.5 GHz Spectrum Analyzer	229, 237	E4860A ParBERT Entry Bundle	407	E7340A/50A Single-Connection, Single-Sweep Network Analyzer Systems (0.045 to 110 GHz)	297
E4411B 9 kHz-1.5 GHz Spectrum Analyzer	229, 237	E4861A 2.6-Gb/s Data Generator/Analyzer Module	407, 431	E7400 Series Drive Test Systems	43, 350-351
E4412A Power Sensor, 10 MHz to 18 GHz	308	E4862A Generator Front-End, 2.6 Gb/s	407, 431	E7415A EMI Measurement Software	335
E4413A Power Sensor, 50 MHz to 26.5 GHz	308	E4863A Analyzer Front-End, 2.6 Gb/s	407, 431	E7476A/77A Series Drive Test Systems	43, 392-393
E4416A/18A Single-Channel Power Meters	45, 303, 305	E4864A Generator Front-End, 1.3 Gb/s	407, 431	E7478 Option 180 Drive Test (Indoor Measurement System)	392-393
E4417A/19A Dual-Channel Power Meters	45, 303, 305	E4865A Analyzer Front-End, 1.3 GSa/s	407, 431	E7478A GPRS/Data Drive Test System	392-393
E4423B/24B/25B/26B ESG-AP Series Analog RF Signal Generators	198, 202, 204	E4873A 81200 User Software	431	E747x, Option 180 Drive Test (Indoor Measurement System)	392
E4430B/31B/32B/33B ESG-D Series Digital RF Signal Generators	198, 205-208	E4875A ParBERT User Software	407	E7490A CDMA Over-Air Maintenance Tool	42-43, 361-362
E4434B/35B/36B/37B ESG-DP Series Digital RF Signal Generators	198, 205-208	E4891A High-Speed Bundle, Two Pair, 1.3 Gb/s	407	E7501A Analog Simulation & Generation Subsystem	56, 199, 218
E4440A Performance Spectrum Analyzer	231	E4892A High-Speed Bundle, Two Pair, 2.6 Gb/s	407	E7580A ProBER 2, 2-Mb/s Handheld Test Set	350-351, 404
E4441A DVB QAM Coder	510	E4893A 660 MHz Generator Bundle (8 outputs)	407	E7585AC PDU Installation Kit	548
E444A Benchlink Spectrum Analyzer	239	E4991/91A RF Impedance/Material Analyzers	47, 482, 484, 487-488, 492	E7590A-AW3/AW5 Rack Cabinets	546-547, 550
E4451A/55A 100/120V PDUs	548, 550	E5022A Hard Disk Read/Write Test System	526	E7685A PDU Installation Kit	550
E4452A/53A/56B/57B 200/240V PDUs	548, 550	E5039A Bit Error Test Module	527	E7694A Mounting Hardware	551
E4458B Solid Side Panel	550	E5090A 2-Port Transmission/Reflection Test Kit	282	E7714AC Fixed Keyboard Rackmount Kit	548, 550
E4460B/61B/62B/63B Plexiglas Front Doors	550	E5100A/B Network Analyzers	273, 281-282, 482	E7749A Solid Side Panel	550
E4466B/67B/68B Tie Kits	550	E5230C Interactive Characterization Software	525	E7792A Tie Kit	550
E4470A 100/120V 200 cfm Fan	550	E5250A Low Leakage Switch	58, 523-524	E7797A Mounting Hardware	551
E4471A 200/240V 200 cfm Fan	550	E5336A/40A/48A/49/61A/63A/73A/74A/77A Probes	461	E8285A CDMA Mobile Station Test Set	368-369, 350-351
E4476B/78B Solid Rear Doors	550	E5346-44701 Support Shroud	461	E8290A Point-of-Service Test Software	368-371
E4477B/79B Vented Rear Doors	550	E5346-60002 High-Speed Mictor Break-Out Adapter	461	E8311A/12A VXI Pulse/Pattern Generators	435-436
E4488A Equipment Shelf for E44900 Series	409	E5346-68701 Five Mictor Connectors, Five Support Shrouds	461	E8356A/57A/58A PNA Vector Network Analyzers	48, 273-275
E4489 STS/DS3 Signal Source	409	E5346A/51A High-Density Adapters	461	E8400A VXI Mainframe	95
E4492A DS3 Bridge Repeater	409	E5348A Probe	461	E8460A Multiplexer	96
E4502A/03A/04A Optical Switches	96	E5500 Series Phase Noise Measurement Solutions	341	E8491B IEEE-1394 Controller Interface (VXI)	260
E4586A NIU Interface	409	E5515B 8960 Series-10 Wireless Communications Test Set	363-364, 366-367	E8505A HDSL Installer's Assistant	409
E4587A DS3 Network I/F Unit Single Housing	409	E5515T 8960 Series-10 IS-2000 Test Sets	363, 365, 367	E8509A Central Office Assistant	409
E4588A 3-Slot NIU-3 Rackmount Equipment Shelf	409	E5920B/C Rack Cabinets	546-547, 550	E8510A Doubler/Remote Assistant	409
E4589A 12-Slot NIU-3 Rackmount Equipment Shelf	409	E6000B Mini-Optical Time Domain Reflectometers	413, 415-416	E8511A Remote Assistant	409
E4594A T1 Test Advisor Undercradle	409	E6053A/58A/60A Rack Optical Time Domain Reflectometers	414	E8590A STS-1 Bridge Repeater	409
E4805B 660-MHz Central Clock Module	407, 430-431	E6090A OTDR Toolkit	414	E8704B/05B/06B RF Shielded Enclosures	57, 378
E4831A 660-MHz Clock/Data Generator Module	431			E8900 Advanced Design System	85
				E8921A/AN Momentum	84
				E9300/01B/H Performance Spectrum Analyzers	49, 304



E9304A Performance Spectrum Analyzer	49, 304
E9320/21A/22A/23A/25A/26A/27A	
Power Sensors	45, 303-304
E9340A LogicWave Logic Analyzer	442, 445
E9801A Dac Express Data Acquisition	
Recorder Software	426
E9812A Data Logger	426
E9814A Data Recorder/Logger	426
ECal Modules	48, 299
EMI Measurement System Software	336
EPM-P Series Power Meters	45
EPM/EPM-P Series Power Meters	
(sensor dependent)	350-351
ESA-E Series Portable Spectrum	
Analyzers	232, 350-351
ESA-L1500A Portable Spectrum	
Analyzer, 1.5 GHz	348, 350-351
ESG-A Series Analog RF Signal Generators	202, 204
ESG-AP Series Analog RF Signal Generators	202, 204
ESG-D/DP Series Digital RF Signal	
Generators	44-45, 205-208, 350-351, 389
ESG-D4000A Digital and Analog Signal Generator	510
ESG-DP Series Digital RF Signal Generators	205-208
Emulite	50, 403
<b>H</b>	
HTBasic for Windows	89
<b>I</b>	
ITEL-45CHVEB GPIB/Parallel Converters	
(International)	245
IVI Driver Standard	422-423
Infiniium DCA	53, 121
Infiniium Series Scopes	61, 116-119
<b>J</b>	
J1518AC Retractable Keyboard	
Rackmount Kit	548, 550
J1519AC Monitor Rackmount Kit	550
J1520AC Plain Shelf	551
J1526C Sliding Shelf	551
J1950A LAN Analyzer Software	402
J1981A Telegra VQT Base Platform	417
J1982A PAMS VQT Upgrade	417
J1983A PSQM VQT Upgrade	417
J1984A T1 VQT Upgrade	417
J1985A E1 VQT Upgrade	417
J1986A Analog VQT Upgrade	417
J2300D Advisor WAN	402
J2899A/VAF Advisor Software Subscription	402
J3446D Advisor LAN-Fast Ethernet	402

<b>L</b>	
LogicWave Logic Analyzer	442, 445
<b>M</b>	
Modular Measurement System	90-92
Momentum	84
<b>N</b>	
N1020A TDR Probe	123
N1025A 1-GHz Differential Probe	123
N1610A/60A Dual DS1/0 Service Advisor	
Tester Tablets	350-351, 408
N1625A Service Advisor xDSL TIMS Test Module	408
N1626A Service Advisor xDSL TIMS-ITU	
Test Module	408
N1627A Service Advisor TDR Test Module	408
N1640A Service Advisor ATM Cell Processor	
Test Module	408
N1645A Service Advisor SONET/SDH Interface	
Module	408
N1660A Service Advisor Dual DS1/0 Test Module	408
N1690A Service Advisor Datacom Test Module	408
N1700A Service Advisor Undercradle	
for the Internet Advisor	408
N1725A/26A/27/28A/29A auroraDuet	
ISDN Testers	350-351, 408
N1735A auroraTempo Frame Relay/	
BER Tester	350-351, 408
N1737A auroraJazz ATM Tester	408
N1738A auroraPresto ADSL Tester	408
N1739A LT2000 TIMS Tester	408
N1810 Family Latching Switches	56, 319
N1810TL/UL SPDT Coaxial Switches	319
N1811TL Bypass Switch	319
N1812UL 5-Port Switch	319
N2216A VXi/SCSI Interface Module	532
N2260A/61A/62A/63A/64A/65A/	
66A/67A/68A/69A/70A/80A/81A	
System Switches	97-100
N2765A/66A/67A/68A Horizontal	
Mini-Probe Sockets	125
N2771A High Voltage Probes	131
N2772A 20-MHz Differential Probe	129
N2773A Power Supply for N2T12A	129
N3300A Series dc Electronic Load Family	62, 166, 168
N3419A Vehicle-Mounted Display System	392-393
N3839A Test Port Cable	301
N6314A/15A Test Port Cables	301
N8972A/73A Noise Figure Analyzers	310-311
NFA Series	50, 310

<b>O</b>	
OPAS 32	396
OmniBER Communications Performance	
Analyzers	51, 411-412
<b>P</b>	
PCI/PCI-X Series Verification Tools	440
PNA Series Analyzers	48, 274-275
PSA	49, 231
ParBERT 81250	51, 405, 407
Portable VoicePrint	396
<b>Q</b>	
Q347B Noise Source	312
Q85026A Waveguide Detector	278, 280
<b>R</b>	
R347B Noise Source	312
R85026A Waveguide Detector	278, 280
Recon	396
<b>S</b>	
SCMVX008 Digital Signal Processor	95
Series 10 8960 Test Set	55, 363
Signaling Advisor Family	50, 403, 408
SpectralBER Testers	52, 405, 410
<b>T</b>	
TS-50 Series RF/Mobile Phone Test Fixtures	57, 378
TS-5500 GSM/CDMA Cellular Phone	
Function Test Platform	350-351, 377
Test Advisor Family	409
Test Aware xi Software	518
TestExec SL Software	55, 86
Testmobiles	462, 549
<b>U</b>	
U85026A Waveguide Detector	278, 280



## V

V1300 Mixed Memory/Logic IC Production Test System	520-522
V85104A V-Band Millimeter-Wave Test Set Module	297
VEE	87-88, 531
VXI Operating System	422-423
VoicePrint	396

## 1

## W

W85104A W-Band Millimeter-Wave Test Set Module	297
WJC 9119L/R High-Frequency Tuner (Downconverter)	96
Walkabout	396
Wedge Probe Adapter	125, 460
Wizard	396

## Trademark Information

Emulite is a registered trademark of Agilent Technologies, Inc.

Celeron, Pentium, and Rambus are Registered U.S. trademarks of Intel Corporation.

LabView is a registered trademark of National Instruments.

Microsoft, MS-DOS, MS Excel, MS Word, MS Windows, Windows 95, Windows CE, Windows NT, Visual Studio, Visual BASIC, Visual C++, and Internet Explorer are Registered U.S. trademarks of Microsoft Corporation.

Oracle is a Registered U.S. trademark of Oracle Corporation.

Netscape Navigator is a U.S. trademark of Netscape Communications Corporation.

UNIX is a registered trademark of UNIX Systems Laboratories.

Third-party product information is included for informational purposes only and does not constitute an endorsement or recommendation by Agilent Technologies, Inc. Third-party product providers are solely responsible for their products and services. Agilent Technologies, Inc. makes no warranties of any kind, express or implied, including the warranties of merchantability, fitness for a particular purpose, and non-infringement of intellectual property regarding third-party product providers, their products, or services. In no event will Agilent Technologies, Inc. be liable for any direct, indirect, special, consequential, or other damages, including but not limited to loss of profits, in connection with third-party product providers, their products, or services.

## Take immediate action: Find, get & buy at the Agilent Technologies web site

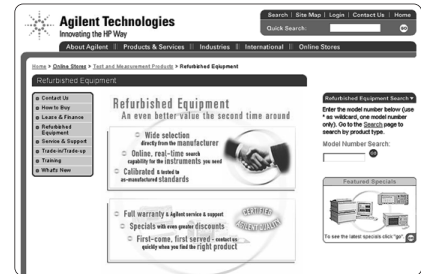
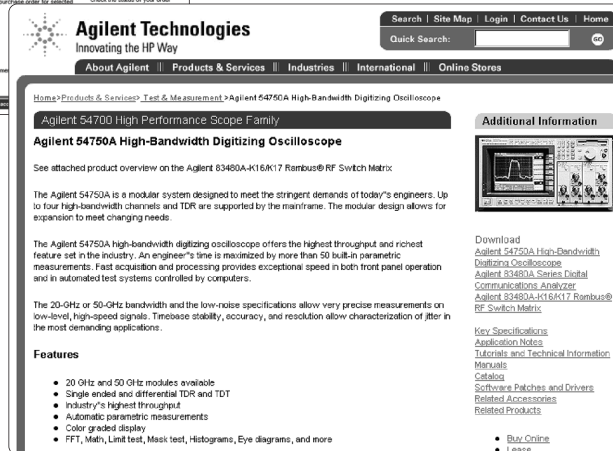

1

### Find

- Product and support information more easily with helpful navigation aids and improved web pages that make it easier to access application notes, product overviews, technical details, frequently asked questions, manuals, software, news releases, education course descriptions and schedules, and much more.

### Get

- Updated comparison data and evaluation guides/tools that facilitate product selections
- Helpful application notes, downloadable interactive application notes, tutorials, online models, and other learning and problem-solving material
- Quick access to customer support services
- Information on recommended replacements for discontinued products
- Information in your local language\*
- The latest information on the status of your Agilent test and measurement order

### Buy

- Selected Agilent products—including scopes, logic analyzers, EDA software, multimeters, data acquisition products, signal sources, counters, power supplies, and more\*
- Refurbished instruments\*
- Accessories\*
- Replacement parts\*

For more information on the test and measurement features, resources, and services available on Agilent's web site, see page 3.

Use our online test and measurement resources and services often!  
[www.agilent.com/find/tmc](http://www.agilent.com/find/tmc)

\*Availability of this feature may be limited; an expansion program is ongoing. Online purchases require a credit card.

For best results, view the Agilent web site with Microsoft's Internet Explorer browser.

## Case studies show customer successes with Agilent



Siemens automotive systems achieves more throughput flexibility at reduced cost with TS 5400 systems.

In the following pages we have compiled a set of examples of the successful “Complete Test Solutions” developed by Agilent Technologies and a customer. These represent large and small companies from around the world, which have a variety of needs. The thing they have in common is that in cooperation with Agilent, they were able to solve a major test and measurement problem. A brief overview of these case studies may give you some ideas about how Agilent can help you improve your business results.

**SS/Loral teams with Agilent to develop payload test systems to meet present and future needs quickly and cost effectively**  
 SS/Loral, communications satellite company, chooses Agilent Technologies to design, and build automated payload test system. Teamwork, allows SS/Loral to concentrate on the satellite, while using the specialized skills of Agilent to create a robust, user-friendly system that meets SS/Loral’s needs and ensured high-performance satellite delivery, with capabilities for extension to future projects. (Page 37)

### Agilent and JOT Test Systems give Bose a tidal wave of manufacturing productivity

To meet deadlines and stay competitive, Bose Corporation decreases cycle times and reduces manufacturing costs, while maintaining highest quality with an Agilent Technologies and JOT Automation integrated solution. (Page 37)

### Agilent’s acceSS7 helps Illuminet improve customer service while enhancing network reliability and efficiency

Illuminet operates the largest unaffiliated Signaling System 7 (SS7) network in the United States, and is growing rapidly. To maintain its high level of customer service, while expanding the network and becoming even more efficient, Illuminet chose Agilent Technologies acceSS7. (Page 38)

### Agilent helps Tellabs cut costs, increase production volumes, and improve product quality

Tellabs chose to upgrade its existing Agilent Technologies test systems to meet manufacturing goals, in part due to results the equipment had already delivered. As a result, Tellabs has doubled manufacturing test throughput and cut defects in half, while reducing overall test costs. (Page 38)

### Motorola AIEG (Europe) speeds production line test development and execution with Agilent TestExec SL

Motorola AIEG (Europe) uses a new Agilent Technologies Test Executive for the automation and execution of functional tests on an automotive unit under test (UUT) and reports the results, achieves improvements in operating and test execution speed as well as speed of development using that platform, thus realizing the ultimate goal of increased throughput. (Page 39)

## SS/Loral teams with Agilent to develop payload test systems to meet present and future needs quickly and cost effectively



Agilent 85121A Payload Test System (PTS) developed for SS/Loral.

Space Systems/Loral (SS/Loral), a \$1.4 billion operation with some 200 satellites to its credit, is one of the prime players in the design and manufacture of communication satellites. A subsidiary of Loral Space and Communications, SS/Loral designs; builds; and tests satellites, subsystems, and payloads at its Mission Control Center in Palo Alto, California.

Regardless of their mission, satellites don't fly until they have undergone complete and comprehensive pre-launch testing. At the same time, satellite manufacturers are continually challenged by aggressive production schedules and rigorous performance requirements. Understanding the special skills and capabilities needed to design and build technically appropriate and cost effective payload test systems (PTS) in-house, while producing state-of-the-art satellite systems, SS/Loral decided to seek the assistance of test and measurement experts, who would free them to focus on what they do best—producing state-of-the-art satellite systems.

As a result, SS/Loral contracted with Agilent Technologies to build a new payload test system. The result was an automated, robust, user-friendly,

algorithm-based payload test system for evaluating the RF performance of communications satellite transponders, telemetry transmitters, and command receivers. Agilent's system has simplified and reduced standard processing time, and ensured high-performance satellite delivery. The test system's modular design also permits easy upgrade and reconfiguration.

The teaming of SS/Loral and Agilent has resulted in significant improvements in the way SS/Loral tests its spacecraft. As SS/Loral moves forward with new developments in the art and science of spacecraft design, it will continue to call upon Agilent's ingenuity in payload test systems. "Among the reasons that we selected Agilent was the fact that our challenges posed no obstacles to them. They have been in the RF business for many years, they've worked closely with us, and they understand our business, so overcoming these challenges was, for them, very easy. Any other company that hadn't had the exposure to this business would have found it much more difficult," stated Duncan Blanks, Deputy Director of Spacecraft Engineering Test Operation, Space Systems/Loral.

## Agilent and JOT Test Systems give Bose a tidal wave of manufacturing productivity

Bose was founded in 1964 by Dr. Amar G. Bose, professor of electrical engineering at the Massachusetts Institute of Technology (MIT). Dr. Bose's findings resulted in significant new design concepts that help deliver the emotional impact of live music. That technology is found in the company's award winning "Wave" Radio music systems. Today, Bose technology is present in the Sistine Chapel, the NASA space shuttles, and the National Theater of Japan, as well as in homes and automobiles around the world.

To meet deadlines and stay competitive, Bose Corporation must decrease cycle times and reduce manufacturing costs while maintaining the highest quality. To do this, Bose uses an integrated solution from Agilent Technologies and JOT Automation to test its consumer audio products.

"Recently, management challenged us to reduce test time for the Bose Wave Radio with CD by 25 to 40 percent," said Brian Morris, a Bose test engineer. "We turned to a combined solution from Agilent and JOT to get the job done."

Bose relies on Agilent 3273 Series 3 Board Test Systems and Agilent 79000 Custom Functional Test Systems for electronic manufacturing test of high-volume consumer electronic products. "Using this Agilent equipment, in conjunction with automated board handlers from JOT Automation, we exceeded management's test time reduction goals for the Bose Wave Radio with CD," said Morris. He concluded, "Helpful, knowledgeable Agilent staff provide outstanding support that reduces costly down time and further helps us meet our test and manufacturing goals."



## acceSS7 helps Illuminet improve customer service while enhancing network reliability and efficiency



Agilent acceSS7 system used by Illuminet for network management.

Founded in 1981, Illuminet operates the largest unaffiliated Signaling System 7 (SS7) network in the United States and is a leading provider of complementary advanced signaling technology and applications to telecommunications carriers. Illuminet specializes in signaling network services and intelligent network solutions for a variety of services such as calling name delivery, calling card validation, wireless roaming and fraud management, network usage measurement, number portability, and other specialized database access functions.

In the past few years, requirements on Illuminet's network have increased dramatically, due to competition and other changes engendered by the Telecommunications Act of 1996 and the explosion in demand for switch-based telecommunications services. "With growth of 30–40 percent a year and a network that a lot of telephone companies depend on, outages are totally unacceptable to us. We need

to be on top of everything in our network and be able to prevent problems before they occur," Ken Helgeson, Director Network Operations, recalled. "We need an operational support system to keep growing the business and to provide the level of quality and service that our customers expect," stated Bruce Johnson, VP Operations and Engineering

Illuminet selected the acceSS7 solution from Agilent as the right operational support product for managing its network. In addition to meeting its stated requirements, Illuminet felt that the Agilent solution could help it attract additional customers because the product was so well known and well-respected in the telephony industry.

"The industry sees us as a company with a very reliable, robust network and as being very customer-focused. The acceSS7 solution has made a significant contribution to our reputation," said Bruce Johnson, VP Operations and Engineering.

## Agilent helps Tellabs cut costs and improve quality

For nearly 25 years, Tellabs has worked in concert with telecommunications service providers to provide solutions for managing and optimizing networks. In the process, the company has developed a reputation as one of the foremost suppliers of specialized communications solutions. As an infrastructure builder, Tellabs is an important partner with local and long distance telephone companies, competitive service providers, cable operators, cellular and other wireless carriers, and government agencies.

Because of the exploding market for telecommunications products increased, their production volume has grown dramatically. To stay competitive, it is vital for Tellabs to continue improving throughput on manufacturing lines while reducing costs and maintaining high quality

Working with Agilent, the Tellabs Long Island Facility team, under Director of Manufacturing Ed Pruitt, decided it could improve productivity, while maintaining high quality, by using recently upgraded test systems from Agilent Technologies. As a result, Tellabs has doubled manufacturing test throughput and cut defect rates in half while reducing overall test costs.

Agilent provided Tellabs with a "Total Solution" consisting of a Series 2 upgrade to its Agilent 5DX X-ray Test System, STC Series 2 upgrades on both of its Agilent 3079 Functional Communications Test Machines, while Tellabs also added a second Agilent 79000 Functional Test System. The upgraded 3079 systems tests boards in seconds without requiring specialized test equipment, highly skilled technicians, complex programming, or simulation.

"Additionally, extra cost savings are realized through reduced floor space requirements, reduced operator labor, improved system support, and improved quality via statistical process control," concluded Pruitt.



## Speeding production line test development and execution at Motorola AIEG (Europe)

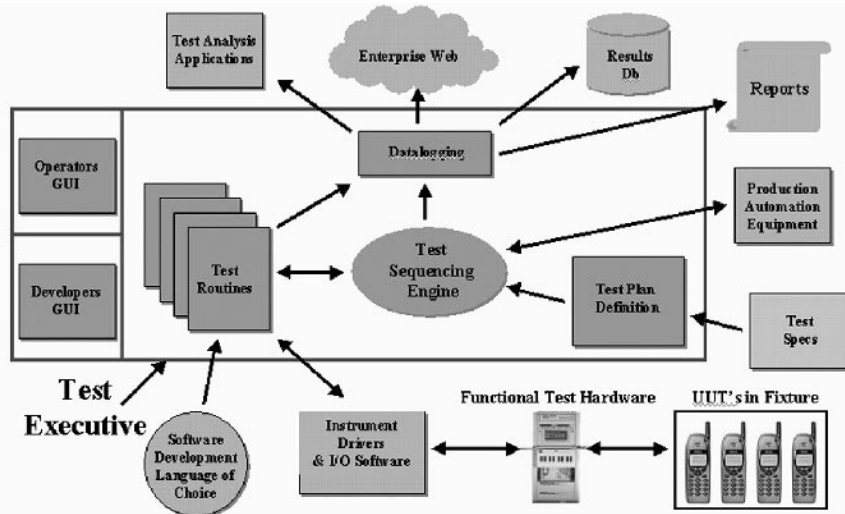

Figure 1—Typical functions of a test executive. Users must be able to configure each module for application-specific needs.

### Motorola Automotive and Industrial Electronics Group's (AIEG) challenge: increased throughput

Motorola AIEG (Europe)'s automotive electronics manufacturing, with facilities in Stotfold, UK and Angers, France, designs and produces electronic modules for a variety of automotive functions. These include engine management, chassis/body control, climate control, and—the newest bright star in the automotive universe—telematics, which enables the vehicle to report its position and mechanical condition in realtime to a central dispatch system for road service.

The Agilent workstation-based platforms Motorola had been using, running on its own software, were becoming obsolete and Motorola AIEG Strategic Test Development was looking for improvements in operating and test execution speed as well as speed of development using that platform, the ultimate goal being increased throughput.

With the announcement of the availability of the significantly improved Series 2, including the Agilent Tech-

nologies TestExec SL, Motorola decided to put it to the test. "We had it in mind for a project that was coming up," says Motorola's Test Engineering Specialist Phil Heredge, "so we went ahead and ordered it. I believe we received the first one off the production line."

Motorola was looking for low cost, high throughput, reliability, and an easy-to-use development environment. The last point was critical and the system answered the need nicely. Bundled with the system was the TestExec SL software environment. "There were a lot of features we liked," says Heredge. "Running on Windows NT, we found it was pretty stable. It provided a good development environment—intuitive and easy to learn. We were able to generate solutions for the factory floor in a significantly reduced number of weeks. And there's a lot of reuse of modules and code with TestExec SL."

### Agilent Technologies Solution

TestExec SL simplifies considerably the development of test executives. A test executive is a management system for automating the execution of

functional tests on a unit under test (UUT) and reporting the results (Figure 1). Its capabilities include test sequencing, limit checking, data logging and export, operator run-time interface, and other functions. An effective test executive program features a modular component architecture, quick and easy system configuration, common instrument support, and extensive measurement routine libraries. Users expect powerful configuration tools that allow them to make simple measurements without writing extensive software routines.

"Phil and his manager, Adrian Carter, took a walk-before-we-run approach to the acquisition of test systems," says Steve Stetler, Agilent Application Engineer. "We were initially successful in introducing one system into Motorola Stotfold that tested the Air Condition Control Module. We worked with Workstation Source, a third-party contractor who handled the quite elaborate mechanical fixturing." Within Europe, Motorola now has a total of ten systems in place, testing engine management, climate control, and telematics products.

### Results and Benefits: higher productivity

Agilent is now working with Motorola on the new telematics modules. The module combines the functions of GPS, GSM, and fault monitoring. And TestExec SL is the platform on which all the tests will be built.

Phil Heredge sums up Motorola's experience with TextExec SL this way: "Our test engineers quickly learned this intuitive development environment. Migrating to this platform allowed them to concentrate on value added tasks rather than source code generation. TestExec SL's many good features include a hierarchical switching path editor, live instrument panels, and the ability to add or remove debug features without compilation. With debug speeded up, we have significantly reduced the time required for developing a functional test solution for manufacturing."

Wireless	41
RF & Microwave	46
Communication Test	50
Lightwave/Component Test	54
Manufacturing Test	55
Semiconductor Test	58
Design Automation	59
General Purpose	59
Digital Design & Debug	62

1

**Innovative products that make a difference**

The exciting new Agilent Technologies products highlighted in this catalog section offer you important new capabilities and new and enhanced benefits. They reflect the wide scope of our research and development investments, as well as our corporate acquisitions. They also underscore Agilent's unwavering commitment to meeting your changing test and measurement needs with continually improved instruments, systems, software, and services.

Among the many characteristics that Agilent products exhibit, and the trends they help drive, are the following:

**More value and affordability**—Greater value, with nothing left out, has been achieved through improved designs, patented measurement techniques, higher integration, and more efficient manufacturing processes.

**Greater ease of use**—Features such as one-button test capabilities, voice control, and sophisticated graphical user interfaces make Agilent instruments easier to operate and help you achieve results more quickly.

**Higher performance**—Extended performance limits permit insights into problems that were previously impossible to analyze.

**Faster test speeds**—Higher measurement throughputs increase productivity in both engineering and production environments, while helping to reduce test costs.

**More powerful methodologies**—Faster, more insightful analysis and troubleshooting techniques let you diagnose problems better and with unprecedented speed.

**Technical breakthroughs**—Unique solutions to long-standing problems, developed by Agilent researchers and engineers, continue our legacy of product innovations.

**Expanded flexibility**—New hardware and software products add more capabilities, including state-of-the-art functionality, boosting the utility of versatile platforms.

**Enhanced familiarity**—Commonly used elements of computer operation have been leveraged to provide familiar environments that allow you to spend more time on your project and less time learning to use an instrument.

**Improved data-analysis capabilities**—Agilent instruments make it easier than ever to complete the entire test and measurement task, including data analysis and report preparation.

**Modular designs**—Modular test solutions give you great measurement flexibility with considerable economy—a combination that offers value now and in the future.

**LAN connections**—More Agilent instruments have LAN connections for intranet and Internet connectivity, facilitating remote operation, data sharing, and access to Agilent services and many other resources.

**Upgradeability**—The flexible architectures of many Agilent instruments enable timely software performance/feature upgrades that extend the equipment's useful life and safeguard your capital investments.

**Inter-system collaboration**—Linkage software allows test systems such as an x-ray inspection machine and an in-circuit tester to collaborate intelligently to decrease test redundancy, reduce fixture complexity, and boost fault coverage.

**Portability**—Many Agilent test and analysis instruments are exceptionally small and lightweight, so they can be easily carried to problem sites for efficient troubleshooting.

**Computer-standard technologies**—Agilent strongly advocates the industry's drive to develop test and measurement solutions that use computer-standard technologies for I/O, instrument access and control, and instrument-based solution development and maintenance.

**Application-specific solutions**—Agilent supports the complete test engineering solution process, from consulting services to fully configured test systems, and offers standard products optimized for key applications such as data communications.

**More products, more solutions**—Agilent Technologies, the worldwide test and measurement leader, offers you the industry's most extensive, most trusted line of standard and custom solutions. The new products for 2001 build on a vast base of existing products. To obtain a more complete picture of how the thousands of Agilent products and services can help you, please refer to the subject index, which begins on page 6.

If you need additional information on a specific application, contact the Agilent Call Center in your region.

## Use time-, frequency-, and modulation-domain analysis to speed communication system design



These vector signal analyzers, linked to EDA software, ease communication system design from first simulation to final hardware prototype.

Agilent Technologies' 89600 series vector signal analyzers (VSAs)—the 89610A (dc to 40 MHz) and 89640A (dc to 2.7 GHz)—have frequency-domain, time-domain, and modulation-domain analysis functions. They give you the measurement tools you need for digital communications applications, especially those that have wideband formats.

Use the VSAs to make measurements on baseband, IF, or RF signals. The analyzers handle a wide span of modulation formats and variable symbol rates, and provide a variety of filters. View measurement results in constellation, eye, trellis, spectrum, or time displays.

### Link analyzer with EDA software

The VSAs can be linked tightly to Agilent's Advanced Design System (ADS) electronic design automation (EDA) software. Now you can use the same tools throughout the design and development phases of your product. Evaluate both the computed results from the simulation software and the measured data from your prototypes using the same processing algorithms.

### Signal quality measurements

The VSA's EVM (error vector magnitude) versus time measurements let you analyze carrier frequency,

symbol clock, filtering, and other DSP problems. Identify unwanted signals in modulated carriers using the EVM spectrum function.

The VSAs have an adaptive equalization function that removes linear errors from I/Q modulated signals by dynamically creating and applying a compensation filter. They also let you analyze signals for instantaneous amplitude, frequency, or phase versus time. Characterize phase noise, oscillator frequency transitions, and transmitter turn-on behavior. Perform statistical measurements of peak, average, and peak-to-average power, including the complementary cumulative distribution function (CCDF), too.

The 89600 series analyzers have extremely flexible triggering. Their PC-based measurement software makes it easy to automate measurements. User-defined macros simplify recording key strokes or mouse clicks so test procedures can be saved and reused.

For more information, see page 260.

For detailed specifications, circle 1 on the reply card (last page) or contact the Agilent Call Center in your region (see page 604).

## Maintain and expand your cdma2000 1XR-TT network



Get the measurement capabilities you need to upgrade your wireless network services.

For most IS-95 operators, cdma2000 SR-1 technology will allow increased spectral efficiency and higher data transfer rates for such applications as the Internet. The Option 200 for the Agilent E6380A tester facilitates wireless network service upgrades.

With this option, the tester is ideal for measuring the performance of cdma2000 SR-1 (1XR-TT) systems. It provides

- a power display for 128 code channels and supplemental channels in bit-reverse order
- a noise power display for each code
- total power and code channel width capability (number of supplemental channels)
- a complex power function that displays power in 128 I and Q code channels prior to short-code spreading
- an I-Q constellation diagram that indicates decision points for one or more symbols
- a function that computes the estimated Rho for cdma2000 signals.

For more information, see page 359.

For detailed specifications, circle 2 on the reply card (last page) or contact the Agilent Call Center in your region (see page 604).

## Reduce test time with the E4406A's EDGE, W-CDMA, and cdma2000 measurement personalities

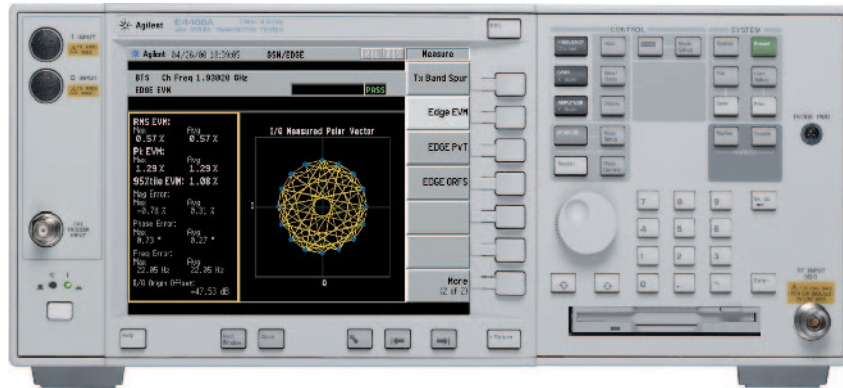

The new and enhanced 2.5/3G measurement personalities for the E4406A VSA offer fast, accurate one-button standards-compliant measurements.

### New EDGE measurement capability

The Option 202 measurement personality adds EDGE measurement capability to the Agilent E4406A vector signal analyzer (VSA). This option enables you to perform fast, one-button, standards-compliant measurements that can help you move your product smoothly from design verification to manufacturing. Quickly and simply make complex measurements, such as:

- error vector magnitude (EVM)
- output RF spectrum (ORFS)
- power versus time (PvT)

A unique measurement algorithm and industry standard filter are used in Option 202. This allows the VSA to display a highly accurate EDGE constellation diagram while simultaneously reporting numerical EVM results. The EDGE measurement personality also includes GSM test capability.

### W-CDMA and cdma2000 enhancements

The W-CDMA measurement personality (Option BAF) and the cdma2000 measurement personality (Option B78) for the E4406A will keep you current with the latest changes to 3G standards specifications. These

personalities enable you to make standards-compliant measurements, using preprogrammed routines, at the touch of a button. The enhancements include:

- code domain analysis measurements to verify the channel structure of the hybrid phase shift key (HPSK) modulation scheme of mobile handsets
- a composite EVM measurement to perform modulation quality analysis, including code domain error, for multiple data channels
- an adjacent channel power measurement that now includes a root raised cosine filter to comply with the latest standard for 3GPP.

New measurements added to Options BAF and B78 include a spectrum emission with mask for spurious search capability (up to 4 GHz), occupied bandwidth and intermodulation distortion.

For more information, see page 379.

For detailed specifications, circle 3 on the reply card (last page) or contact the Agilent Call Center in your region (see page 604).

## CDMA over-air maintenance tool



Perform proactive CDMA base station maintenance without leaving the vehicle.

The Agilent E7490A CDMA over-air maintenance tool is used to make diagnostic measurements of IS-95 and J-STD-008 CDMA base stations over the air. The system lets you perform proactive maintenance of even hard-to-reach base stations efficiently and economically. With an increasing number of base-station pole-top deployments, this tester gives cell-site technicians fast and easy first-level diagnostics without getting out of their vehicle.

The E7490A software runs on a PC that interfaces with an Agilent digital receiver and/or a CDMA mobile phone. The receiver-based measurements include code domain power, pilot signal measurements, and dynamic traffic channel measurements. The phone-based testing exercises individual base station channel elements. The over-air measurement system also has data recording and playback capability.

The Agilent E7490A maintenance tool is completely scalable with Agilent drive test system products. The optional capabilities can be integrated at any time.

For more information, see page 361.

For detailed specifications, circle 4 on the reply card (last page) or contact the Agilent Call Center in your region (see page 604).



## Drive-test systems facilitate evaluating and troubleshooting wireless networks, outdoors and indoors



Examine impairments to 3G and GPRS networks during a drive through of a coverage area, and even while walking through a building.

Agilent's portable solutions for wireless network air interface testing are ideal for outdoor—and indoor—optimization, transmitter site selection and evaluation, network performance characterization, and troubleshooting. They can help you speed up network turn-on, optimize network performance, maximize productivity, and minimize drive test cost.

### Optimize 3G networks

Based on the scaleable E7470-series platform, the new E7476A and E7477A drive test systems are optimization solutions for 3G networks. The E7476A (for W-CDMA networks) and E7477A (for cdma2000 networks) help you eliminate network problems quickly, while also improving network quality, decreasing downtime, and reducing costs. These drive test systems can be fully integrated into other E7470-series products, so you can perform drive testing across multiple network technologies and frequency bands simultaneously.

### Drive-test GPRS networks

As service providers and equipment manufacturers roll out General Packet Radio Service (GPRS), they can use the Agilent E7478A drive test system to quickly optimize and trou-

bleeshoot their networks. The system provides mobile measurement reports and protocol decode information to allow air interface characterization and fast problem resolution.

### Measure GPRS data uplinks/downlinks

The convergence of cellular telephones and the Internet mandates that wireless networks be optimized for data transfer. New options for Agilent E7478A drive test products allow end-to-end testing of data connections with independent uplink and downlink measurement results. Key data characteristics, data throughput, and network accessibility can be measured and recorded for post processing analysis.

### Measure indoor RF coverage

Customers want to use their wireless phones anywhere—including indoor locations. Now you can measure the quality of indoor RF coverage using the same tools used for outdoor drive testing. The Option 180 extends the capabilities of an Agilent drive test system to characterize 3G, GPRS, CDMA, GSM, TDMA, and AMPS networks indoors. The indoor measurement system has a pen-tablet computer for quick data entry onto a computerized floor plan, and a suspension system to support the computer. A customized backpack



The vehicle-mounted display system makes Agilent's wireless network optimization tools easier to use.

holds the receiver(s), phones, batteries, integrated antennae, and all the associated cabling.

### Vehicle-mounted display

The Agilent N3419A vehicle-mounted display system improves safety, boosts efficiency, and allows real-time troubleshooting while using Agilent's E7470-series drive test systems and the E7490A over-air maintenance tool. It consists of a bright display, adjustable pedestal mounting, and a custom keypad with application-specific keys.

During a drive through a network coverage area, the N3419A system makes it easy to examine network impairments as they occur. Information such as location, time of day, vehicle traffic conditions, and terrain can be noted to aid problem solving. Essential measurement functions such as starting and stopping calls, recording data, and turning alarms on and off are performed by pressing just one key.

*(Safe driving must always be maintained when using this equipment. Availability of the Agilent N3419A is subject to local regulations.)*

For more information, see page 392.

For detailed specifications, circle 5 on the reply card (last page) or contact the Agilent Call Center in your region (see page 604).



## Verify your W-CDMA designs with a fully coded signal

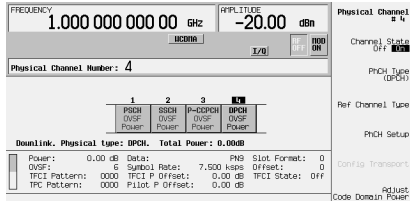

The flexible Option 200 personality lets you change many channel parameters.

Option 200 personality enables the Agilent ESG-D/DP family of signal generators to produce a fully coded real-time W-CDMA signal. This new capability enables developers to verify mobile receiver and base station designs for accuracy and standards compliance. The Option 200 complements the Option 100 personality, which provides a partially coded multi-carrier W-CDMA, useful for component testing.

With the latest revision to the 3GPP standards, the Option 200 personality supports reference measurement channels for BLER/BER. It generates physical data, control, and synch channels, while allowing adjustments of the channel parameters. Data bits can be inserted at the transport layer or physical layer, so the ESG-D/DP/Option 200 combination can be used for different stages of testing.

For more information, see page 205.

For detailed specifications, circle 6 on the reply card (last page) or contact the Agilent Call Center in your region (see page 604).

## Expanded capability for GSM mobile-phone repairs



Service shops can use mobile station test set to economically increase their cellular telephone repair and calibration capability.

The Agilent E6392B GSM mobile-station test set has more capabilities for module-level repair and calibration. The frequency range has been extended to cover the U.S. PCS1900 frequency band. A dual-band hand-over test capability allows service technicians to easily verify whether a GSM900/DCS1800 dual-band phone can properly hand off calls between the GSM and DCS networks. There are now six channels in the test set for fixed traffic-channel measurements, providing greater flexibility for testing hand-overs in multiple bands.

To aid the adjustment and calibration of phones after repair, the test set now includes an 11-V dc source, an async test mode for measuring transmitter power, and optional 0.5-dB signal generator steps for receiver testing.

### Cut GSM phone repair costs

The E6392B test set provides module-level repair capability for the price of an entry-level, go/no-go tester. By extending troubleshooting, repair, and calibration activities to local shops, GSM service providers, and mobile-phone-repair organizations can keep equipment costs in line and reduce the number of "no trouble found" phones that get sent back to the manufacturer.

For more information, see page 373.

For detailed specifications, circle 7 on the reply card (last page) or contact the Agilent Call Center in your region (see page 604).

## Complete test solution for cdma2000 designs

FREQUENCY	REF	AMPLITUDE	
1.000 000 000 00 GHz		-10.00 dBm	
CDMA2K			
Channel Number: 2			
1	2	3	4
F-PICH	F-SYNCH	F-PICH	F-PICH
N/A	N/A	N/A	N/A
Forward SR1, F-SYNCH.			
Power:	0.00 dB	F-SYNCH Type:	JSTD8
Mod:	32	Data Rate:	1.20000 Mbps
SID:	0007	SYS_TYPE:	000000000
NID:	0001	PRNT:	00
		LP_SEC:	00
		P_REV:	01
		PLP_REV:	01
		LP_SEC:	00

This is the cdma2000 link control display of an ESG-D/DP signal generator with the Option 201 personality.

With the Option 201 personality, real-time cdma2000, you can use an Agilent ESG-D/DP signal generator to simulate a base-station transmitter or a mobile receiver to create SR1 IS-2000 signals.

Conduct frame or bit-error tests and functional tests of the mobile unit's protocol handling. Option 201 is backward-compatible with IS-95 systems using Radio Configurations 1 or 2.

The ESG-D/DP/Option 201 combination produces fully-coded channels, including pilot, sync, paging, quick paging, and fundamental and supplemental traffic channels, plus OCNS. Channels are easily configurable using the built-in table editor. You can control the power level, FIR filter type, PN offset, Even-Second delay, and other parameters, depending on the type of channel.

**For more information, see page 206.**

**For detailed specifications, circle 8 on the reply card (last page) or contact the Agilent Call Center in your region (see page 604).**

## TDMA and CDMA peak and average power measurements



Peak and average power meters and sensors allow fast measurements on wireless communications signals

The Agilent EPM-P series power meters, the E4416A single-channel and E4417A dual-channel models, are used with the E9320 power sensors to make accurate power measurements. You can perform peak, peak-to-average ratio, and average power measurements on all the common modulation formats used in wireless communications. Time-gated power measurements can also be made using the meters' comprehensive triggering features.

The EPM-P series power meters are compatible with both the E-series and 8480-series power sensors. When used with E9320 sensors, the meters can perform power measurements at rates up to 1000 readings per second over the GPIB. This speed reduces test times and improves throughput.

The flexibility of the power meters is enhanced by the range of products in the E9320 power sensor family. Two frequency ranges are available: 50 MHz to 6 GHz, and 50 MHz to 18 GHz. There are also three modulation bandwidths:

- 300 kHz for TDMA signals
- 1.5 MHz for CDMA (IS-95A) signals
- 5 MHz for wideband-CDMA signals

Select the modulation bandwidth required for your application, while maintaining the widest possible dynamic range.

**For more information, see page 303**

**For detailed specifications, circle 9 on the reply card (last page) or contact the Agilent Call Center in your region (see page 604).**

## High-performance mobile communications dc sources with battery emulation



Replace the battery and power adapter/charger during design and test of digital wireless appliances.

High-performance Agilent 66319B/D dual-output and 66321B/D single-output dc power sources meet the performance testing demands that wireless appliances place on their batteries. The dc sources offer very fast output transient response, very low voltage drops, and excellent output stability for either short or long load leads (up to 6 meters). In addition, they provide three current measurement ranges for increased measurement accuracy. This ensures accurate off-mode, standby-mode, and talk-mode currents measurements.

### Increase throughput up to 30x

The sources' fast transient output technology and fast measurement system allow test throughput increases of up to 30x, compared to general purpose dc power sources. In addition, the 66319B/D and 66321B/D allow the elimination of fixture capacitors and resistors, which improves test throughput and current measurement accuracy.

### Simulate battery resistance

The dc sources have a built-in output resistance programming capability that can be used to simulate the resistance of the internal battery pack used in a wireless device. Various batteries can be simulated, including Ni-Cad, Ni-mH, Li-Ion, and Li-Poly types.

### Powerful graphics software

The Agilent 14565A device characterization software can be used with the dc sources to create a powerful wireless appliance test solution that doesn't require any programming.

For more information, see page 173.

For detailed specifications, circle 10 on the reply card (last page) or contact the Agilent Call Center in your region (see page 604).

## Microwave source for broadband digital communications



Use I/Q modulation to perform stimulus response tests on broadband digital communication systems.

The Option UNG adds I/Q modulation capabilities to the Agilent E6432A VXI microwave synthesizer, making the synthesizer an ideal solution for emerging broadband digital communications applications, satellite tests and complex radar testing. Option UNG provides a 40-MHz I/Q bandwidth over the 10-MHz to 20-GHz range of the E6432A.

For wireless designs that use Bluetooth technology, the fast switching speed provided by the E6432A synthesizer with the Option UNG allows the generation of Bluetooth format signals that can do the full-range frequency hopping as defined in the specifications.

For more information, see page 217.

For detailed specifications, circle 11 on the reply card (last page) or contact the Agilent Call Center in your region (see page 604).

## Impedance/material analyzer provides accurate measurements at up to 3 GHz



Analyze components and materials accurately at frequencies up to 3 GHz with the RF impedance/material analyzer and its test fixtures.

The Agilent E4991A RF impedance/material analyzer offers a new level of impedance measurement performance and offers exceptionally powerful and versatile analysis functions. It can help circuit designers better evaluate components at frequencies up to 3 GHz. The E4991A also has dielectric/magnetic material measurement capabilities over a wide frequency range: 1 MHz to 1 GHz.

The analyzer's list-sweep function improves test throughput, and its test signal-level ranges enable the evaluation of devices under actual operating conditions. An internal VBA programming function is also useful for research and development applications. These and other functions allow drastic improvements to engineering productivity.

The E4991A's color display provides a clear view of measurement settings and results. The analyzer uses a Windows-type user interface. Menus that provide easy access to advanced features. The standard TCP/IP-compliant LAN interface implements seamless connectivity for direct data readouts to a PC. SMD test fixtures for the E4991A simplify measurements and help ensure accurate, repeatable results.

**For more information, see page 487.**

**For detailed specifications, circle 12 on the reply card (last page) or contact the Agilent Call Center in your region (see page 604).**

## SMD test fixture for impedance measurements up to 3 GHz

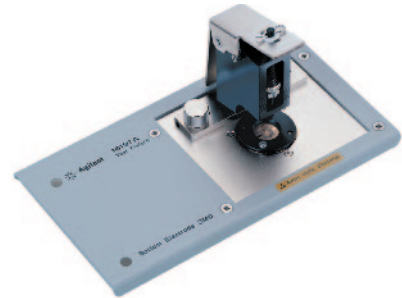

The Agilent 16197A can help you perform accurate measurements of chip inductors and other passive RF components.

The Agilent 16197A test fixture improves impedance evaluations of bottom electrode surface-mount devices (SMDs) up to 3 GHz. The fixture accommodates various sizes of SMDs; as small as 1005 (mm)/0402 (inch) and as large as 3225 (mm)/1210 (inch).

Positioning adjustments are eliminated by the test fixture's device guide, which places the SMD precisely over the measurement terminals. As a result of the precision positioning of the SMD, the 16197A boosts measurement repeatability. A pressure arm comes down vertically and presses the SMD down onto the measurement terminals, helping to ensure stable contact. A lever swiftly moves the pressure arm up and down for fast operation.

**For more information, see page 488.**

**For detailed specifications, circle 13 on the reply card (last page) or contact the Agilent Call Center in your region (see page 604).**



## Calibrate vector network analyzers quickly, easily, and accurately



Perform accurate, repeatable measurements of components with electronic calibration.

Traditional mechanical calibrations require intensive operator interaction, which is prone to errors. With Agilent's electronic calibration (ECal) products, the operator simply connects an ECal module to the network analyzer, then the ECal software controls the rest of the process. This approach is much easier than performing a full 2-port calibration of a network analyzer using a mechanical calibration kit. The ECal solution produces accurate results, yet takes less than half the time and requires 50% fewer connections.

The improved ECal modules are easily controlled directly from the USB port of an Agilent PNA series analyzer. They can also be used with all other Agilent network analyzers, controlled via a PC running Windows 95 or NT 4.0.

The ECal modules (male-female, male-male, and female-female types) are available with Type-N (50  $\Omega$  and 75  $\Omega$ ), 3.5-mm, Type-F, and 7-mm connectors.

For more information, see page 299.

For detailed specifications, circle 14 on the reply card (last page) or contact the Agilent Call Center in your region (see page 604).

## Network analyzer has fast sweep speeds and a wide dynamic range

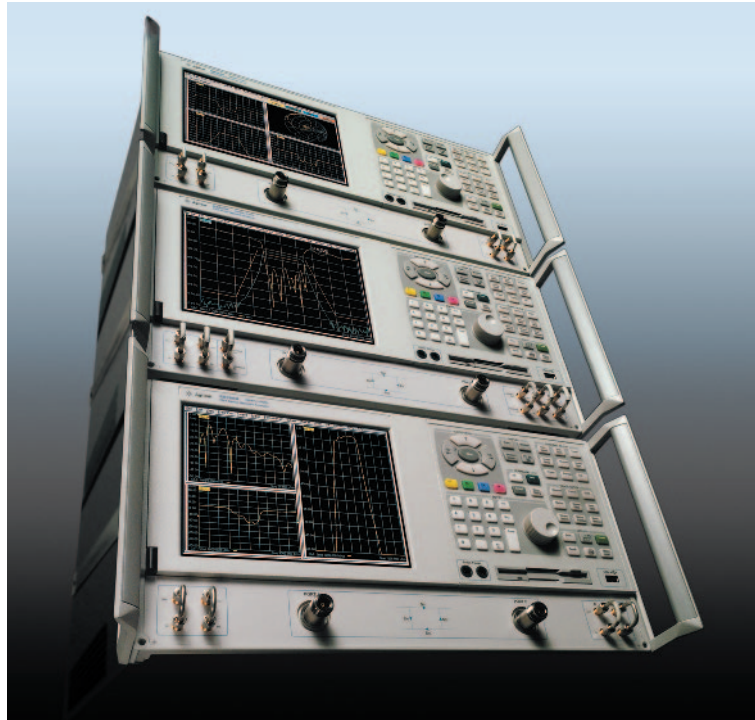

These network analyzers are designed to meet your measurement needs now and well into the future.

Is designing and testing leading-edge RF devices pushing the limit of your existing test equipment? If so, consider buying an Agilent PNA series network analyzer: the 3-GHz E8356A, 6-GHz E8357A, or 9-GHz E8358A. They have the capabilities needed to meet your measurement needs both now and well into the future.

The PNA series analyzers feature exceptional performance, connectivity, and automation flexibility. They provide fast sweep speeds (35  $\mu$ s/point), wide dynamic range, and low trace noise. Now you will be able to see aspects of your component's performance that you never could before.

The analyzers' connectivity features help you achieve new levels of integration for your device-measurement processes. Move information to and from the instrument using a variety of built-in interfaces. Save data easily to the built-in floppy disk, internal hard drive, or external PC or server

using the familiar Windows GUI. For hard copies, send measurement results to any Windows-compatible printer with a LAN, USB, serial, or parallel interface. Control other equipment in the test station directly from the network analyzer, using any of the built-in GPIB, LAN, serial, or parallel interfaces. The LAN interface also enables remote troubleshooting.

Automate your test processes using several powerful automation approaches. You can control the PNA series network analyzer using SCPI commands, or gain the speed and connectivity advantage of COM/DCOM. Programs can be executed internally on the network analyzer or externally on your PC.

For more information, see page 274.

For detailed specifications, circle 15 on the reply card (last page) or contact the Agilent Call Center in your region (see page 604).



## Performance Spectrum Analyzer (PSA)



The new spectrum analyzer has the speed, accuracy, and dynamic range you need to analyze all the communication signals you encounter.

The Agilent Performance Spectrum Analyzer is the first in a series of modern, high-performance, signal analysis tools. The analyzer measures and monitors complex RF and microwave signals, providing comprehensive spectrum analysis for communications systems and components. It gives you unprecedented access to new levels of measurement capability with optimized speed, accuracy, and dynamic range for every signal in your system.

### Speed, accuracy, and resolution

Whether you are tuning oscillators manually or performing high-volume, automatic test on wireless products, the Agilent PSA gives you a real-time response. It offers state-of-the-art speed in tuning and measurement data transfer. Thus, the analyzer eliminates measurement bottlenecks to help you meet time-to-market goals.

To reduce the tolerance required in your measurement budget and improve your product yields, you simply increase the accuracy of your measuring instrument. The PSA has excellent specifications in all aspects of amplitude accuracy: absolute amplitude accuracy, log fidelity, and resolution bandwidth switching error.

Generally, it's critical to use the correct resolution bandwidth for the measurement being made. Resolution that's too narrow causes unnecessarily slow sweep speeds; resolution that's too wide causes a loss of signal detail. The PSA optionally has 161 resolution bandwidths (1 Hz to 8 MHz). Optimize your measurements for speed or dynamic range.

### Dynamic range and sensitivity

An analyzer with a wide dynamic range lets you view small signals in the presence of large signals without introducing distortion products. The excellent dynamic range of the PSA is made even more useful by an optional 2-dB step attenuator.

High sensitivity allows faster spur searches and easier signal identification because wider bandwidths can be used. The PSA has excellent sensitivity. If needed, you can boost that sensitivity to exceptional levels by using an optional preamplifier.

**For more information, see page 231.**

**For detailed specifications, circle 16 on the reply card (last page) or contact the Agilent Call Center in your region (see page 604).**

## Sensors for low-frequency, high-power measurements



The power sensors allow accurate low-frequency/high-power measurements.

The Agilent E9304A power sensor has a 9-kHz to 6-GHz measurement frequency range. This power sensor provides the low frequency coverage required for electromagnetic compatibility (EMC) and electromagnetic interference (EMI) test applications, and they can also be used to measure transmitter power and receiver sensitivity in the installation and maintenance of very low frequency (VLF) to high-frequency (HF) radios.

You can make wide-dynamic-range, high-power measurements with the E9300H/01H (1 W, +30 dBm) and E9300B/01B (25 W, +44 dBm) sensors.

Like all Agilent E-series power sensors, the E9304A, E9300B/H, and E9301B/H have their calibration factors stored in EEPROM. They operate only with the Agilent EPM and EPM-P series power meters.

**For more information, see page 304.**

**For detailed specifications, circle 17 on the reply card (last page) or contact the Agilent Call Center in your region (see page 604).**

**Easy, accurate, and repeatable noise figure measurements with the NFA**



Easy to set up and use, the NFA is a dedicated Noise Figure Analyzer that lets you view the measurement data graphically.

**Improve the design and manufacture of your receiver components**

Whether you're working with systems, subsystems, subassemblies, or discrete devices, each of your components add noise that affects the overall performance of a communication design. By measuring and reducing noise figures, you can give your components a competitive edge.

Comprehensively characterize your device under test at a reasonable cost. The NFA series analyzers offer the traditional benefits of a noise-figure meter, plus the added features and functions most often requested by engineers and technicians:

- Easy measurement setup for amplifiers and frequency converting devices
- Color graphical display of noise figure and gain versus frequency
- Low instrument uncertainty for accurate noise figure measurement

The NFA series comes with a 3-year warranty as standard.

**Achieve more in less time**

With an NFA series analyzer, you can make better measurements, quicker. It's easier to set up measurements correctly, view measurements in different formats, and print the results or save them to disk. On-screen limit lines simplify pass/fail testing.

Perform your measurements to the latest, most exacting specifications with extended frequency coverage, high-performance features, and selectable measurement bandwidths. Repeatable, reliable measurements provide results that you can trust.

These noise figure analyzers can help you produce more robust designs and prototypes in the lab. They can also help you achieve higher yields and throughput in manufacturing.

**For more information see page 310.**

**For detailed specifications, circle 18 on the reply card (last page) or contact the Agilent Call Center in your region (see page 604).**

**Graphical signaling emulation for acceptance and interoperability testing**

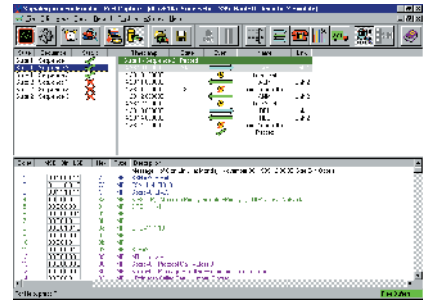

The optional add-on emulation tool is fully integrated with Signaling Advisor's standard monitor capabilities.

The Agilent Emulite graphical emulation tool is a powerful addition to the Agilent Signaling Advisor family—testers that assist in testing SS7 and related protocols in wireline and wireless telecommunications networks. Ideal for acceptance, interoperability, and start-up tests, or maintaining services/equipment, the Emulite tool significantly reduces the time to isolate and resolve signaling problems. The tool uses decodes derived from the signaling standards, so it produces data that is helpful when arbitrating solutions between vendors.

The Emulite tool's easy-to-use graphical operation enables engineers to avoid complex test programming. Tests can be created or modified easily, using the text used in the standards. This lets engineers focus on the content and sequencing of signaling messages, and respond more rapidly to signaling problems or changing test requirements.

**For more information, see page 403**

**For detailed specifications, circle 19 on the reply card (last page) or contact the Agilent Call Center in your region (see page 604).**

## Parallel solution for testing high-speed digital communication components

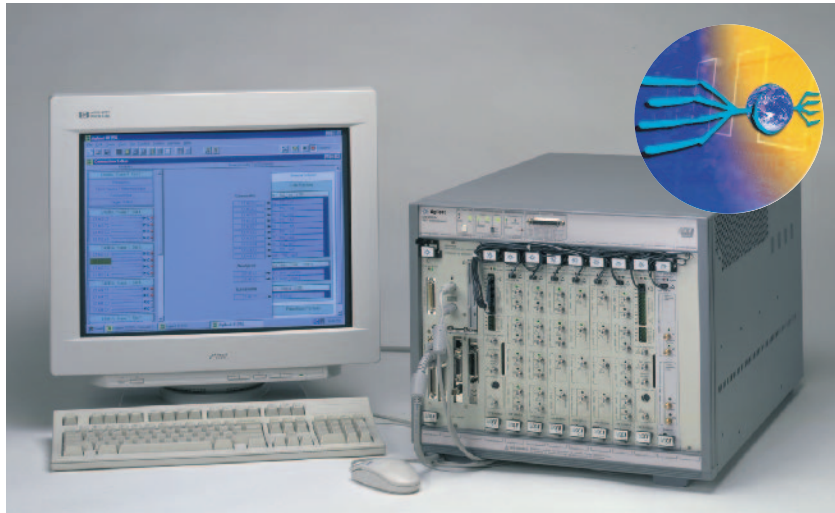

The tester has a fast, familiar user interface. You can tailor its flexible hardware to fit your application needs.

The Agilent Technologies ParBERT 81250 is a modular parallel bit error ratio (BER) solution for testing high-speed (up to 2.67 Gb/s) digital communication components such as multiplexers/demultiplexers, FEC devices, and transceivers/receivers. If you are working on high-speed communication ports, modules, or devices, this system can help you thoroughly test those products in R&D and increase your throughput in manufacturing. The tester offers solutions for OC-48, OC-192, and OC-768 testing.

Use the tester to generate pseudo-random word sequences (PRWS) and user-defined and standard PRBS up to  $2^{31}-1$  on parallel lines. You can analyze bit error ratios with user-defined data, PRBS, or mixed data. This allows you to test devices with several channels in parallel, saving test time and cost.

The ParBERT 81250 offers data generation and analysis capabilities with sequencing and looping, so you can realistically stress your device under test (DUT). Sequences can contain memory-based (up to 8 Mbit) and/or PRBS/PRWS data. The system can generate and analyze single-ended, low-voltage, and differential signals, including true differential signals. Thus, you can test devices based on logic technologies such as LVDS, ECL, and PECL.

Because the tester compares the data from the DUT with the data you expect and performs an analysis in real-time, you view the BER while the measurement is being made.

**For more information, see page 405**

**For detailed specifications, circle 20 on the reply card (last page) or contact the Agilent Call Center in your region (see page 604).**

## Perform fast, accurate tests of SDH and SONET devices to 2.5 Gb/s



The analyzer provides differential clock/data interfaces for SONET/SDH BER and jitter testing.

The Agilent OmniBER 725 communications performance analyzer offers extensive measurement capability at 2.5 Gb/s, 622-Mb/s, 155 Mb/s and 52 Mb/s rates. It is ideal for manufacturers building components and modules for SDH/SONET network equipment. Optical and binary interfaces allow testing where access to electrical clock and data signals is required. The analyzer provides a range of bit error ratio (BER) and jitter measurements, to ITU-T/Bellcore standards, so the error and jitter performance of modules can be thoroughly verified before integration into operational systems.

To rigorously test fiber-optic transmitter and receiver modules, the OmniBER 725 is equipped with concatenated payloads for testing the entire signal structure. This is vital for representative jitter testing. In addition, the analyzer can generate unframed pseudo-random binary sequence (PRBS) test patterns to help ensure error-free device performance.

**For more information, see page 412**

**For detailed specifications, circle 21 on the reply card (last page) or contact the Agilent Call Center in your region (see page 604).**



**10-Gb/s optical interfaces provide complete link for BER testing**



The transmitter/receiver combination create a complete optical link for system testing or optical fibers test.

The Agilent 83433A optical transmitter and 83434A optical receiver combine to provide a complete optical link for BER testing 10 Gb/s SONET/SDH and IP optical links and networks. They can also be used for substitution testing of commercial transmitters and receivers.

The 83433A transmitter handles a wide range of input signal levels in varying environmental conditions. When combined with the Agilent 71612B error performance analyzer, the transmitter produces high-fidelity, low-jitter waveforms for STM-16/OC-48, STM-64/OC-192, and other transmission rates from 2.4 Gb/s through 10.7 Gb/s.

The 83434A receiver detects optical signals at levels down to -16 dBm. For eye diagram analysis, the receiver can trigger a scope at 9.953 Gb/s to help ensure that the display accurately represents all possible bit combinations in the data stream.

For more information, see page 476

For detailed specifications, circle 22 on the reply card (last page) or contact the Agilent Call Center in your region (see page 604).

**Perform DWDM and SONET/SDH functional tests to 10 Gb/s**

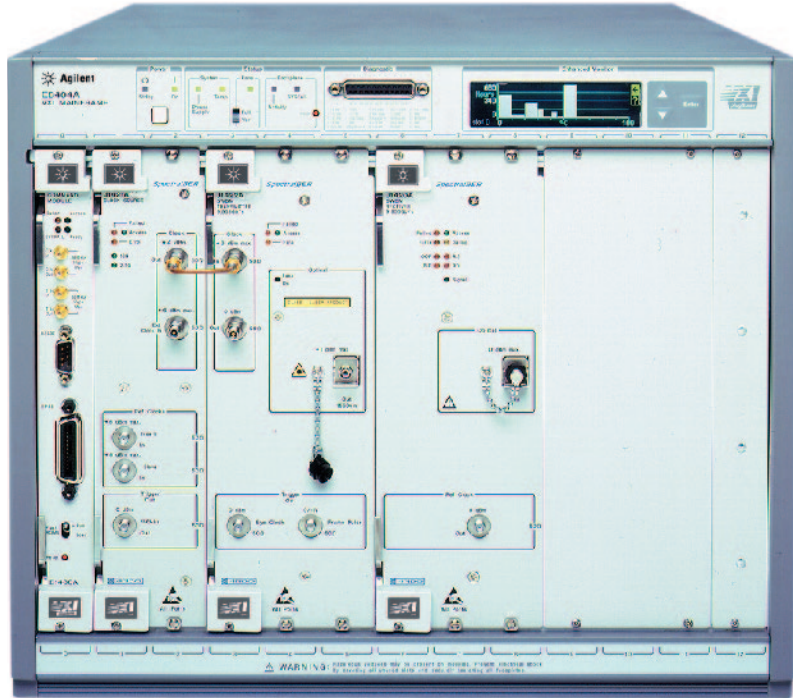

Use the flexible, cost-effective testers for testing high speed DWDM, OXC, and OADM communication systems.

Agilent's family of SpectralBER testers are flexible, cost-effective solutions for testing DWDM, OXC, and OADM communication systems. The modular VXI-based testers handle 10 Gb/s, 2.5 Gb/s, and multi-rate (2488/622/155 Mb/s Tx/Rx) applications, and can be tailored to match a wide range of current and future testing needs.

The SpectralBER testers have a high test-port density enabling manufacturers to test systems with high channel counts simultaneously for fast, convenient throughput.

The testers can be used to perform functional BER test of optical add/drop multiplexers, optical translators, transponders, and multi-channel systems.

For more information, see page 410

For detailed specifications, circle 23 on the reply card (last page) or contact the Agilent Call Center in your region (see page 604).



## Digital communications analyzer performs complex compliance measurements quickly and easily



Make compliance measurements just by touching one button on the Infiniium DCA's display screen.

The Agilent 86100A Infiniium DCA is a high-speed, wide-bandwidth oscilloscope with digital communications analysis capabilities. Simple to operate, it lets you complete complex compliance measurements in seconds. Primary measurements are instantly accessible. You can perform entire procedures, such as compliance eye analysis, with just a touch of the screen. Whether you're building components, systems or networks, the Infiniium DCA's measurements can give you confidence that your transmitters meet industry standards.

### Integrated optical, electrical receivers

Integrated optical and electrical receivers provide high accuracy for measuring and characterizing light-wave communications waveforms. Integrated optical receivers cover standard rates for SONET/SDH, Gigabit Ethernet, and Fiber Channel. Electrical receivers have 20-GHz or

50-GHz bandwidths. Filters are easily switched in for compliance test, or out for wide-bandwidth analysis. You can also configure the 86100A for the specific bandwidth filtering and sensitivity you need.

The Infiniium DCA has a flexible, modular platform, which allows new firmware upgrades and modules to be added in the future. It is also compatible with receiver modules used in the Agilent 83480A and 54750A communications analyzers. Code used in automated test systems designed around the 84380A and 54750A can be leveraged for use in the 86100A with only minor modifications.

For more information, see page 121

For detailed specifications, circle 24 on the reply card (last page) or contact the Agilent Call Center in your region (see page 604).

## Powerful error analysis for rapid problem identification



Intuitive operation allows you to concentrate on the problem—not the test equipment.

The Agilent 86130A BitAnalyzer—serial bit error ratio (BER) tester—combines an integrated pattern generator and error detector to help you quickly solve your design and manufacturing problems.

- In the design environment, you need to verify component performance and focus in on problems quickly. The BitAnalyzer's intuitive instrument setup gives you immediate visibility of settings, and produces an excellent waveform. Significantly, it also provides powerful error analysis capabilities from SyntheSys Research, which give you clear insight into the underlying causes behind error conditions.
- In manufacturing applications, you can save test time by combining the 86130A BitAnalyzer with the 86100A Infiniium DCA. This combination of instruments allows easy setup of BER measurements, and fast go/no-go mask testing.

For more information, see page 406

For detailed specifications, circle 25 on the reply card (last page) or contact the Agilent Call Center in your region (see page 604).

## Simplify the characterization of lightwave components and systems



The DWDM channel analysis function provides accurate power, noise, and channel-wavelength measurements.

The performance capabilities, features and built-in measurement applications of Agilent 86140B-family optical spectrum analyzers (OSAs) simplify the time-consuming tasks of characterizing optical components and systems. Each OSA includes a wavelength division multiplexing (WDM) application with the patented dual-sweep measurement technique, which is the quickest way to measure and record channel power, wavelength, and optical signal-to-noise ratio.

Available in benchtop and portable platforms, these OSAs have a remote-control capability for automated test applications. They produce tabular displays of channel wavelength, power, OSNR, gain tilt, and peak-to-peak power deviation. The data can be viewed on the display, printed on the built-in printer, or saved as CSV files on the internal floppy drive.

One of the OSAs, the 86141B, has a monochromator output and a power meter function. The monochromator output lets you isolate a single channel from a WDM signal or perform other filter functions. The power meter lets you maximize power transfer in applications such as fiber alignment, or make quick measurements of broadband optical power.

**For more information, please see page 472**

**For detailed specifications, circle 26 on the reply card (last page) or contact the Agilent Call Center in your region (see page 604).**

## Accurately characterize 40-Gb/s optical components



The 50-GHz lightwave component analyzer characterizes the 40-Gb/s components being developed for OC-768 applications.

Lightwave transmission systems require accurate, repeatable characterization of their components to guarantee high-speed performance. The Agilent 86030A 50-GHz lightwave component analyzer accurately and reliably characterizes the 40-Gb/s components being developed for OC-768 applications. The analyzer measures the bandwidth of optical receivers, and photodiodes. It can also determine the bandwidth or reflection of O/E (optical/electrical), E/O, O/O, and E/E devices in magnitude and/or phase.

The 86030A lightwave component analyzer uses a factory characterized and calibrated internal O/E receiver to provide calibrated measurements of optical components. This lets you verify that the devices you design and manufacture meet industry standards.

**For more information, see page 478**

**For detailed specifications, circle 27 on the reply card (last page) or contact the Agilent Call Center in your region (see page 604).**

## High-throughput capacitance meter for production environments



The capacitance meter enables higher test throughput, while providing high measurement accuracy.

The Agilent Technologies 4288A 1-kHz/1-MHz capacitance meter is an optimum solution for high-speed production testing of the ceramic capacitors. The meter offers improved measurement speed and accuracy with no decrease in test efficiency. Several features ease handler system integration: a built-in comparator that sorts the measurement results into a maximum of nine bins, an opto-isolated handler interface, a GPIB interface, and more.

For measurement systems that use a component scanner, the capacitance meter offers the optional scanner compensation function. Error compensation can be performed independently for each scanner channel. This minimizes not only the measurement error in each channel, but also inconsistencies and the error in measured values between channels.

**For more information, see page 498**

**For detailed specifications, circle 28 on the reply card (last page) or contact the Agilent Call Center in your region (see page 604).**

## Multi-format mobile manufacturing test set helps you meet your production goals



This wireless communications test set provides a competitive edge in high-volume, automated mobile phone manufacturing test.

In high-volume mobile manufacturing, test throughput and test yield are the keys to meeting production output goals. The Agilent Technologies 8960 Series 10 wireless communications test set offers manufacturers immediate competitive advantages. Developed for high-volume, automated mobile phone manufacturing test, the proven 8960 Series 10 offers speed, accuracy, repeatability, multi-format capability, ease of programming, and all in a format-flexible architecture. These features can help lower test costs and raise production outputs.

The 8960 Series 10 test set can be configured for GSM, GPRS, TIA/EIA-136, and AMPS mobile phone testing. IS-2000 mobile phone test with multi-format capability will be added mid year. Multi-format test capability allows manufacturers to test multi-format phones with a single test set, change production from one format to another to meet changing demand, or manufacture mobile phones with different formats on the same line. For the manufacturer, this means faster response to market changes, less downtime for changeovers, and improved test set utilization.

### Test IS-2000 mobile phones

A single-format version of the 8960 test set is available for early-to-market IS-2000 mobile phone manufacturing test. The IS-2000 test mode application provides IS-2000 testing without call processing using mobile phone test modes. This single-format 8960 test set will be upgradeable to multi-format capability when IS-2000 call processing functionality is introduced mid year.

The test set's format-flexible architecture is designed to grow with 3G mobile phone technologies. Agilent has designed the 8960 series 10 test set to meet the needs of mobile manufacturers now and into the future. As mobile phone technology advances, new formats will be added and the hardware will be upgraded.

For more information, see page 363.

For detailed specifications, circle 29 on the reply card (last page) or contact the Agilent Call Center in your region (see page 604).

## Test executive software improves manufacturing test productivity

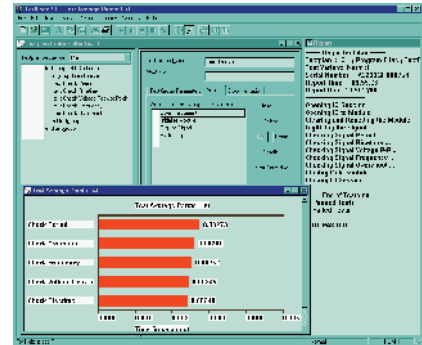

The software offers rapid test system development and a fast, simple-to-use execution environment.

The Agilent E2011E TestExec SL software platform helps test engineers improve their productivity. It provides valuable usability tools that enable them to spend less time writing software and more time running tests. The software also helps manufacturers standardize their functional testing. They can deploy the proven E2011E test executive not only plant-wide, but globally as well.

The TestExec SL software supports the most popular test development environments, including C/C++, Visual Basic, Basic for Windows, LabVIEW, LabWindows/CVI and VEE. Usability tools such as the Action Wizard, Test Profiler, and Switch Manager aid system configuration and make it easier to optimize system performance. The Throughput Multiplier enables the system to test multiple devices simultaneously without the need to add hardware or write custom software.

For more information, see page 86.

For detailed specifications, circle 30 on the reply card (last page) or contact the Agilent Call Center in your region (see page 604).



## High-reliability coaxial switches

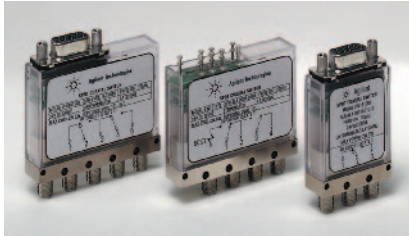

**These electro-mechanical latching switches reduce test system downtime in high-volume wireless manufacturing applications.**

Agilent's N1810 family of electro-mechanical latching switches combine long life with excellent repeatability and handle signals from dc to 26.5 GHz. Three-, four-, and five-port switches are available, with and without 50-Ω terminations.

These switches help reduce downtime for your test platform by protecting against failure and the need for recalibration after failed parts are replaced. Agilent switches are designed to meet warranted performance specifications throughout their entire lifetime. Reliability is a top priority.

The standard switch has a female D-subminiature 9-pin connector. Solder lugs are available as an option. Other options include mounting brackets, indicators, interrupts, TTL/5V CMOS compatible drive, and your choice of 5-V, 12-V, or 24-V coil voltages. For test platforms that require extra performance, some N1810-series switches offer higher isolation, lower SWR, and reduced insertion loss.

**For more information, see page 319.**

**For detailed specifications, circle 31 on the reply card (last page) or contact the Agilent Call Center in your region (see page 604).**

## Compact VXI subsystem is a high-throughput solution for ATE applications



**This analog signal generation and simulation subsystem is an excellent choice for manufacturing test applications.**

The Agilent E7501A is a compact, ATE-optimized stimulus subsystem for high-throughput stimulus/response measurements and high-performance signal simulation applications. It combines the modular components of a VXI microwave synthesizer, a VXI baseband arbitrary waveform generator, and stimulus-focused software package.

The analog generation and simulation application software—a component of the Agilent Technologies Signal Studio—provides an easy-

to-use interface that simplifies the creation and delivery of arbitrarily modulated signals.

The software also automates the process of characterizing and correcting for ATE signal path effects for output power and AM/FM characteristics.

**For more information, see page 218.**

**For detailed specifications, circle 32 on the reply card (last page) or contact the Agilent Call Center in your region (see page 604).**



## Complete, high-quality test fixture solution for mobile phones and other RF/wireless devices



1

These versatile kits simplify the development of test fixtures for RF/mobile phone products.

Products in the Agilent TS-50 series are complete test fixtures in kit form, containing the key components needed to create reliable, high-quality test fixtures for RF/mobile phones. The fixtures are highly versatile and adaptable, designed to work optimally with Agilent test equipment, and with test equipment from other suppliers.

With these kits you can build a custom fixture for testing virtually any assembled phone, RF device, or phone PCB. The fixture can be reconfigured and used with other products. There is no need to design a new test fixture for every new type of phone. The board fixture can also be reused by creating a new probe plate with the appropriate pins.

### Shielded Enclosure

Included in the TS-50 series is the Agilent E8704B RF-shielded enclosure. It can be used in testing many RF devices, including assembled mobile phones and the circuit boards and components they contain.

For more information, see page 378.

For detailed specifications, circle 33 on the reply card (last page) or contact the Agilent Call Center in your region (see page 604).

## Ultra-advanced parametric test solution aids fast device development, improved process yields



The parametric tester has better measurement precision and resolution, an ultra-low noise floor, and fast settling times for low-current measurements.

The Agilent 4073A is an ultra-advanced parametric tester. It is designed specifically to meet the needs of the leading-edge semiconductor laboratories and fabrication lines developing next-generation semiconductor devices. It builds on the performance and reliability demonstrated by the large installed base of over 2000 systems (4062 and 4070 family) at major independent device manufacturers and wafer foundries, and the many 4071 and 4072A testers used in pioneering 300-mm wafer fabrication facilities, worldwide.

The improvements implemented in the 4073A were determined by system-on-a-chip (SOC) designs, copper interconnects with low dielectric materials, and other IC technology trends. The new instrument can handle advanced parametric tests, as well as flash memory cell evaluations, ring oscillator tests, and WLR tests. It offers excellent performance with an ultra-low noise floor, and has fast

low-current measurement settling times and improved measurement precision and resolution. Use it to make DRAM cell evaluations that require current measurement below 100 fA, for example. The 4073A is also ideal for making resistance evaluations of advanced Cu interconnects and for performing matching tests for new analog devices that require measurement capabilities <1 mV.

With this total testing solution, you can quickly make both lower current measurements and very low voltage measurements in production environments. Tighten your measurement guard bands and reduce your overall cost of test.

**For more information, see page 522.**

**For detailed specifications, circle 35 on the reply card (last page) or contact the Agilent Call Center in your region (see page 604).**

## Semiconductor parameter analyzers: more performance and functions

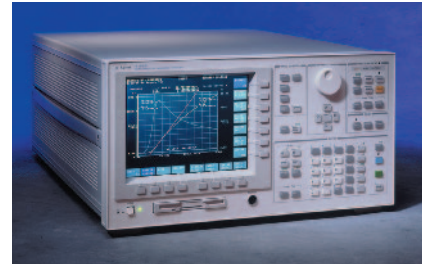

The analyzers are complete solutions for analyzing and evaluating semiconductor processes and devices.

The Agilent 4155C and 4156C semiconductor parameter analyzers provide major improvements in both measurement performance and functionality compared to the popular 4155C/56C models they replace. The new analyzers are complete solutions for analyzing and evaluating state-of-the-art semiconductor processes and devices. They offer the high accuracy, high reliability, and measurement flexibility that have made the 4155 and 4156 series the de-facto standards in the semiconductor industry.

Enhancements incorporated into the 4155C and 4156C analyzers include a redesigned voltage measurement unit with better resolution, an added SMU quasi-static C-V measurement capability (obtained using the ramp voltage), and a brighter front-panel LCD with a wider viewing angle.

For simplified benchtop system integration, the semiconductor parameter analyzers allow interactive control of the Agilent E5250A low-leakage switching mainframe.

**For more information, see page 523.**

**For detailed specifications, circle 36 on the reply card (last page) or contact the Agilent Call Center in your region (see page 604).**

## EDA tools make it easier to use powerful simulation software

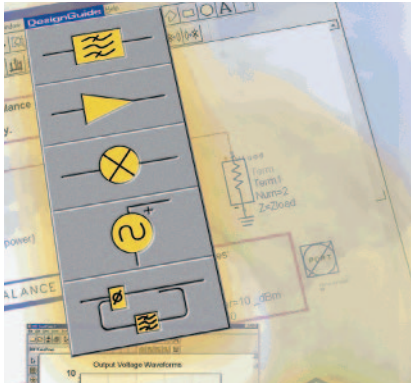

The application-specific expertise built into the DesignGuides facilitates quick product design and simulation.

Whether you are a new or occasional user of the Agilent Advanced Design System (ADS) unified design environment, or even an expert user who must gain new design proficiency quickly, you can benefit measurably from the application insight built into the DesignGuides series of EDA tools. The first five DesignGuides cover passive circuits (E5610A/AN), power amplifiers (E5611A/AN), oscillators (E5612A/AN), PLLs (E5613A/AN), and linearizers (E5614A/AN). Other guides are planned.

Each DesignGuide makes it easier to apply the powerful simulation technologies of the ADS to a specific design problem. It leverages the best practices of industry experts, providing design aids such as predetermined goals, predefined syntax, and preconfigured data displays. Now you can access the capabilities of the EDA environment without spending time learning basic functions and creating your own design aids. Save time and get your products to market faster.

For more information, see page 84.

For detailed specifications, circle 37 on the reply card (last page) or contact the Agilent Call Center in your region (see page 604).

## Oscilloscopes help you capture and see subtle signal details



The scopes have more channels, deep memory, a high-definition display, and powerful triggering, so you can acquire and view important signal details you might otherwise miss.

Today's mixed analog and digital and microcontroller-based system designs are causing fundamental changes in the capabilities needed in an oscilloscope. The five 60-MHz or 100-MHz models in the Agilent 54620 series address today's requirements.

Two 2 + 16 channel mixed-signal oscilloscopes (MSOs) combine 2 scope channels with 16 logic channels to show slow analog and fast digital signals simultaneously. The 4-channel, 100-MHz scope is ideal for applications with higher analog content. The 2-channel models deliver all the basic 56620-series benefits at value prices.

### 2 MB behind each channel

All models feature 2-MB MegaZoom deep memory behind every channel. This lets you easily look deep into design interactions—capture long time spans, then quickly zoom in to look at details. The high-definition

display maps the deep memory into 32 levels of intensity on a screen with superior horizontal resolution. Now you can see subtle details never before visible. The 54620 series scopes respond instantly to control or signal changes because they have a fast update rate: 25 million vectors per second.

The many other standard features in all models include

- powerful triggering, including edge, pulse width, pattern, and I<sup>2</sup>C
- RS-232 and parallel ports
- built-in 1.44-MB floppy drive
- automatic measurements and FFTs
- built-in Quick Help in 9 languages

For more information, see page 108.

For detailed specifications, circle 38 on the reply card (last page) or contact the Agilent Call Center in your region (see page 604).



## 80-MHz function/arbitrary waveform generator with pulse capabilities



The 80-MHz function/arbitrary waveform generator provides standard, arbitrary, and pulse waveforms at an affordable price.

The Agilent 33250A improves on the popular 33120A function/arbitrary waveform generator, offering nearly five times the performance. Its 80-MHz bandwidth lets you handle more diverse applications than ever before.

A wide variety of built-in signals, custom arbitrary waveforms, and higher-frequency pulse capabilities (up to 50 MHz) help you tackle more difficult testing challenges. Direct digital synthesis (DDS) techniques create stable, accurate output signals with low distortion.

The generator's color graphical display, softkey menus, and graph mode work together to simplify the creation of complicated waveforms such as modulation. Follow the softkeys and on-screen help to set up your waveform, then verify the results with graph mode.

Standard features of the function/ARB generator include sweep, burst, modulation, and an external 10-MHz clock reference, as well as GPIB and RS-232 connectivity and a 3-year warranty.

The 33250A gives you great capability and performance at a price less than you might expect to pay for such an outstanding instrument.

**For more information, see pages 163.**

**For detailed specifications, circle 39 on the reply card (last page) or contact the Agilent Call Center in your region (see page 604).**



## Software expands the capability and utility of Infiniium-series scopes

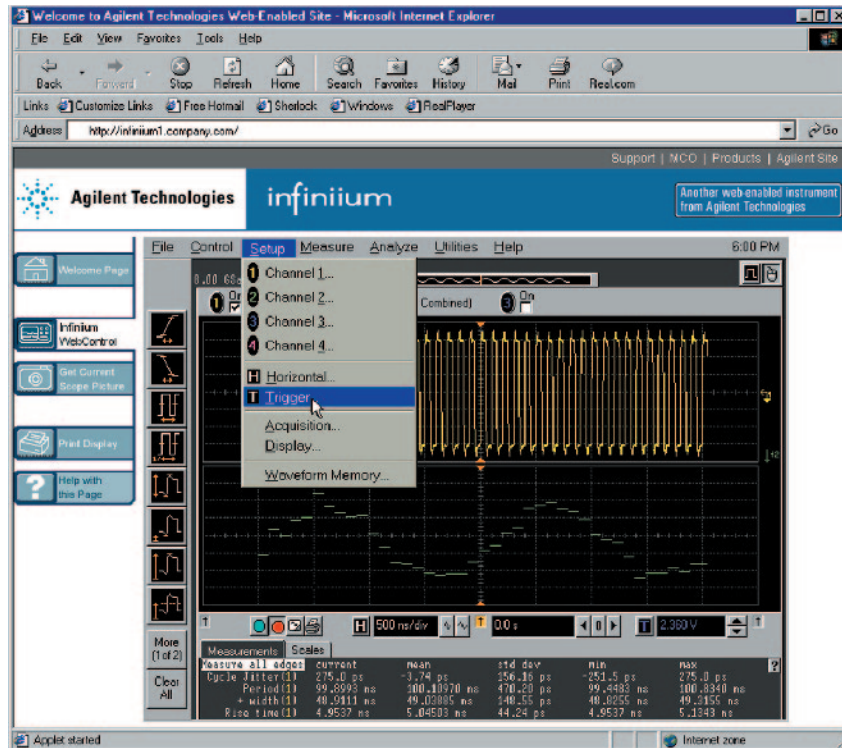

Features of the software—Web-enabled and GPIB-over-LAN connectivity, e-mail on trigger, and an enhanced measurement package—can make your job even easier.

The latest software for the Agilent Infiniium scopes, Version 4.0, can make your job easier because it offers

- Web-enabled connectivity
- GPIB over LAN capability
- e-mail on trigger capability
- enhanced measurement functions (some functions available only on model 84845A or higher)

The software's Web-enabled connectivity feature allows you to remotely display and control your Infiniium scope from any Java-enabled Web browser over the scope's built-in LAN interface. You can also send GPIB commands over a LAN to control your Infiniium scope or set it up to send an e-mail with a bit map of the display screen when the scope triggers on an intermittent event. Now you don't have to be in your lab to view and control the instrument!

The enhanced measurement package includes additional waveform math functions that allow you to plot measurement results as a function of time, the ability to compute statistics on a suite of measurements, and more.

The Version 4.0 software is now included in all six Infiniium-series scopes. It is also available free to owners of Infiniium scopes; contact your Agilent sales office or visit our website:

[www.agilent.com/find/infiniium\\_software](http://www.agilent.com/find/infiniium_software)

For more information on Infiniium, see page 116.

For detailed specifications, circle 40 on the reply card (last page) or contact the Agilent Call Center in your region (see page 604).

## High-bandwidth differential scope probes



Differential signal measurements are easy to make: combine a differential probe and an Agilent Infiniium scope.

The Agilent 1154A and 1159A high-bandwidth differential probes are valuable accessories for Infiniium-series scopes. The 1154A has 500-MHz bandwidth. Its 10X gain and 10:1 attenuation allow a maximum of 100:1 attenuation. The 1159A offers 1-GHz bandwidth and 1:1 attenuation, making it ideal for use with fast, low-voltage signals.

The 1154A and 1159A have an input resistance of 1 M $\Omega$  and a low input capacitance (<6 pF) to minimize circuit loading. The CMRR is >40 dB at 10 MHz for 1154A, and >19 dB at 500 MHz for the 1159A, without external attenuators connected.

The probes have external ac coupling, which eliminates dc and simplifies measurements of ac voltage. Their high gain and low input capacitance make them ideal choices for viewing single-ended signals.

For more information, see page 129.

For detailed specifications, circle 41 on the reply card (last page) or contact the Agilent Call Center in your region (see page 604).

## Fast electronic loads



**High-speed electronic loads provide significant throughput gains for dc power supply test systems.**

The high-speed electronic loads in Agilent's N3300A series provide significant operating speed improvements. They also have additional features that allow further reductions test time and additional gains in system throughput.

The loads have a modular design that is easy and flexible for system configuration. Up to six load modules can be installed in one mainframe.

Improved programming accuracy is provided in all operating modes with 16-bit D/A converters and lower output ranges. Similar accuracy improvements have also been made to the built-in measurement system, which provides many advanced capabilities formerly available only by adding extra equipment. Each module contains a DMM and a digitizer that can make simultaneous voltage and current measurements.

**For more information, see page 166.**

**For detailed specifications, circle 42 on the reply card (last page) or contact the Agilent Call Center in your region (see page 604).**

## Affordable dc power supplies with programming interfaces



**This expanding family of power supplies provides 30 W to 100 W of clean, stable power at affordable prices.**

The six new Agilent E3640A series dc power supplies deliver 50-W and 80-W single outputs, and 60-W and 100-W dual outputs. Each comes standard with GPIB/RS-232 interfaces and full programmability support. The dual-output models provide two isolated power supplies and can display two voltages or currents simultaneously.

For manual testing or automated test system applications, these reliable, low-cost supplies are easy to use and provide excellent value. All models deliver clean, reliable power with dependable regulation.

The E3640A series gives you the flexibility of dual output ranges and an easy-to-read vacuum fluorescent dual display. Front-panel and rear-panel output terminals simplify setups. The output load is protected against over-voltage. SCPI programming and free software drivers for the Agilent VEE and National Instruments LabView environments ease integration into automated test systems.

**For more information, see page 188.**

**For detailed specifications, circle 43 on the reply card (last page) or contact the Agilent Call Center in your region (see page 604).**

## PCI-X verification solutions

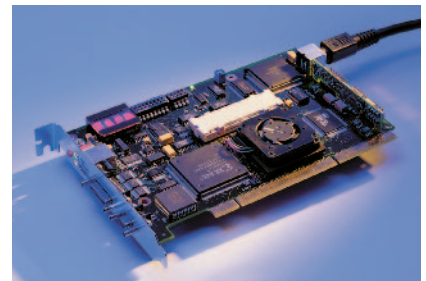

**The exerciser/analyzer and target master card aid the development of PCI-X devices.**

The Agilent E2929A PCI-X exerciser/analyzer and the E2922A PCI-X master target card ease the testing and verification of computer devices and subsystems that use 133-MHz PCI-X I/O bus technology.

The exerciser/analyzer combines a PCI-X protocol checker, an exerciser that generates PCI-X transfers, and a PCI-X state logic analyzer. (A logic analyzer adapter from Future Plus adds PCI-X protocol check and analysis capabilities to Agilent 16700-series logic analyzers). Software included with the E2929A addresses the needs of design development, validation, and compliance testing.

The master target card has just the PCI-X exerciser and protocol checker capabilities. It's operated by the C-API through the PCI-X interface, and integrates easily into test environments. An optional design-verification test library (E2977A) contains transaction-level tests and data-level stress tests.

**For more information, see page 440**

**For detailed specifications, circle 44 on the reply card (last page) or contact the Agilent Call Center in your region (see page 604).**

## Powerful, flexible, easy-to-use logic analysis system



Access the 16702B logic analysis system's powerful measurement and analysis capabilities via an intuitive user interface.

The Agilent 16702B logic analysis system has a large touch screen display that provides quick and easy access to key logic analysis functions and displays, as well as simultaneous views into system activity. Hot keys give instant access to the most frequently used displays, while the front-panel knobs provide a quick and intuitive way to change vertical and horizontal scaling, move markers, scroll through data or waveforms, or change the values of variables.

Powerful measurement and analysis capabilities, combined with the flexibility of a modular system, let you customize a logic analysis system to your specific needs. Multiple, time-correlated views of system behavior (from analog signals to source code) let you view symptoms in the domain best matched to the problem.

Available measurement modules for the 16702B system provide

- up to 8160 channels of logic analysis
- state clock speeds up to 400 MHz
- timing analysis sampling up to 2 GHz
- state/timing memory depth up to 32M samples
- oscilloscope bandwidth up to 500 MHz
- pattern generator clock speeds up to 300 M vectors/s
- pattern generator memory depth up to 16M vectors
- emulation capabilities

**For more information, see page 449.**

**For detailed specifications, circle 45 on the reply card (last page) or contact the Agilent Call Center in your region (see page 604).**

## 300-MHz pattern generator module enhances logic analyzer family

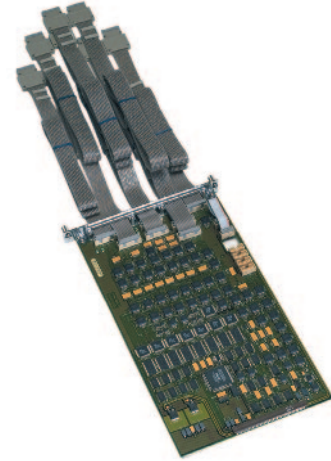

With this digital pattern generator, you can check your prototype quickly, using only one instrument.

The Agilent 16720A digital pattern generator module—part of the 16700-series logic analysis system—is an ideal tool for performing functional tests on your digital design. Check the functional characteristics of your prototype, and see how your target responds to specific signals or clock speeds. In automated test environments, use the pattern generator to run design verification tests quickly, with only one instrument. Configure up to 240 stimulus channels in one Agilent 16700-series mainframe.

If you need memory depth on your vector sequence, the pattern generator provides up to 16M vectors of stimulus memory. Now you can program your most extensive and complex vector patterns into this test instrument to exercise your device under test in the most difficult application environment. Offering speeds as high as 300M vectors/s, the 16720A is a key signal source solution for high-performance digital debug and verification.

**For more information, see page 453.**

**For detailed specifications, circle 46 on the reply card (last page) or contact the Agilent Call Center in your region (see page 604).**



## Make reliable state measurements on high-speed buses

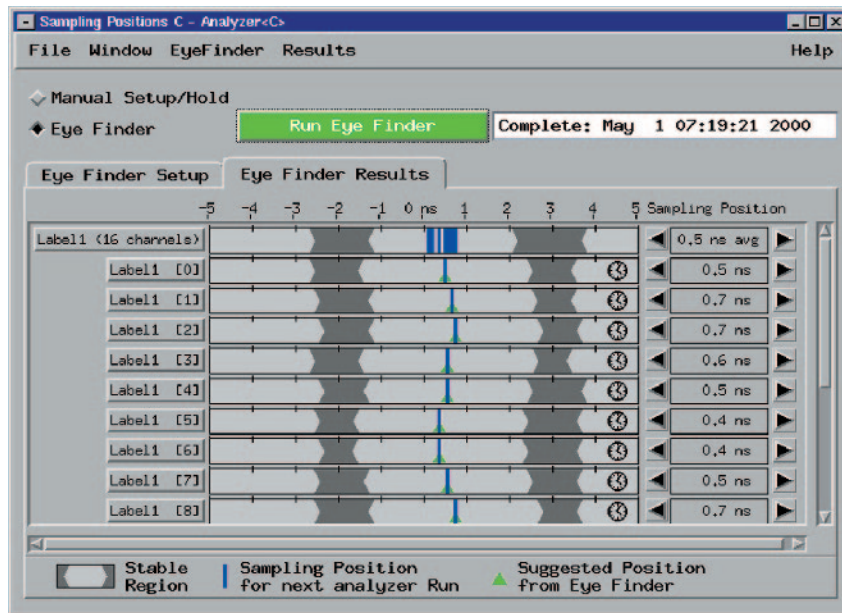

Agilent's eye finder examines the signals coming from the circuit under test and automatically adjusts the logic analysis setup and hold window on each channel.

The Agilent 16750A, 16751A, and 16752A logic analysis modules deliver the performance needed to develop and debug the complex, high-speed digital designs of next-generation computers, networking equipment, and communications systems.

The analysis modules provide

- 400-MHz state speed, which is critical for accurately capturing state data at full speed on high-speed data buses.
- memory depth up to 32M samples, so you can capture the clues needed to solve difficult and hard-to-reproduce problems.

- hardware enhancements that allow you to rapidly analyze large data sets.
- Eye finder technology, which automatically adjusts the setup and hold times on every channel with 100-ps resolution. This technology eliminates manual adjustments and gives you the highest confidence in accurate state measurements on high-speed buses.
- 2-GHz timing analysis, with simultaneous state and timing data available through a single probe connection, across all channels, all the time.
- VisiTrigger technology, which combines powerful trigger functionality with a graphical user interface that is easy to understand and use.
- High channel count. You can configure up to 340 channels in one Agilent 16700-series mainframe, or up to 5440 channels in a multiple-mainframe setup.

For more information, see page 450.

For detailed specifications, circle 47 on the reply card (last page) or contact the Agilent Call Center in your region (see page 604).



## Agilent's web site: Get news, updated product and support information, and more, 24 hours a day.

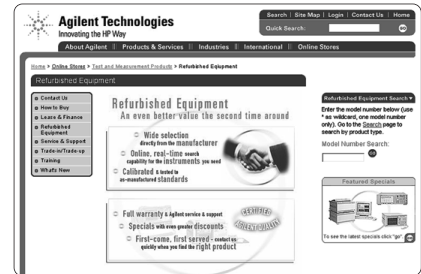
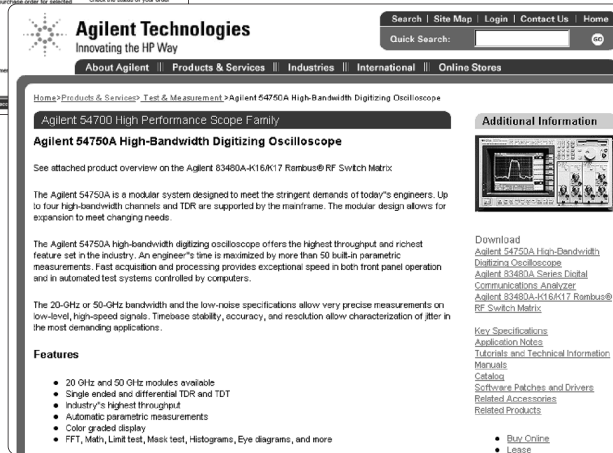

### Resources Available Online

- Product and support information more easily with helpful navigation aids and improved web pages that make it easier to access application notes, product overviews, technical details, frequently asked questions, manuals, software, news releases, education course descriptions and schedules, and much more.
- Updated comparison data and evaluation guides/tools that facilitate product selections
- Helpful application notes, downloadable interactive application notes, tutorials, online models, and other learning and problem-solving material
- Quick access to customer support services
- Information on recommended replacements for discontinued products
- Information in your local language\*
- The latest information on the status of your Agilent test and measurement order

### Take Action

- Selected Agilent products—including scopes, logic analyzers, EDA software, multimeters, data acquisition products, signal sources, counters, power supplies, and more\*
- Refurbished instruments\*
- Accessories\*
- Replacement parts\*

For more information on the test and measurement features, resources, and services available on Agilent's web site, see page 3.

Use our online test and measurement resources and services often!  
[www.agilent.com/find/tmc](http://www.agilent.com/find/tmc)

\*Availability of this feature may be limited; an expansion program is ongoing. Online purchases require a credit card.

For best results, view the Agilent web site with Microsoft's Internet Explorer browser.

## 2 Support & Services

66 Product Support, System Integration, Consulting and Training Services

### At Agilent,

Our service and support promise is simple: We maximize value, minimize risk, and eliminate headaches over the life cycle of your test and measurement equipment.

Call today to learn how our promise works to your advantage.

Quick Selection Guide	68
Our Promise and Your Advantage	69
Hardware and Software Support Services	70
Success Story: Lucent Technologies	73
System Integration Services	74
Success Story: Henkel Waschmittel GmbH	75
Consulting	76
Training and Education	77
Success Story: Microelectronics Technology, Inc.	78
Channel Partners	79

“Tyco Submarine Systems, Ltd. expressed confidence in our capabilities to deliver timely technical service and support at each of the 15 landing stations.”

Jim Young, Agilent U.S. Field Operations

## Agilent support services: How can we help?

Whether you need a fast answer about equipment operation or a factory full of custom test systems, Agilent's service and support team is ready to help. We've built a comprehensive set of services with one goal in mind: giving you the tools and information you need to succeed on the job, no matter what your job may be.

### Contacting Agilent for support

The Agilent T&M web site is a growing source of online support information, available 24 hours a day, 7 day a week. We recommend you start there. If you do not find your answer, click on "Assistance" to find the easiest way to contact Agilent for help.

Web: [www.tmo.agilent.com](http://www.tmo.agilent.com)

No access to the web? In the US:

Phone: 1-800-452-4844

For fax and email, request a form by calling 1-800-452-4844.

For all other locations, please refer to page 604 for your nearest Agilent office.

### Our Promise: Delivering on expectations

We want your Agilent equipment to deliver the performance you expect. If you need assistance, we provide a range of support from verifying proper operation to clarifying information in the manuals.

Our Promise Page 69

Our web site: [www.tm.agilent.com](http://www.tm.agilent.com), offers extensive information:

- Online operating manuals
- Product features and specifications
- Product and application notes
- FAQs
- Service notes
- Catalog requests

### Your Advantage: The power of choice

If you want additional services, Your Advantage provides a selection of engineering, repair and support services to help you through the entire life cycle of your test systems:

Your Advantage	Page 69
Hardware repair and calibration	Page 70
Software support	Page 70
On-site support	Page 71
Application consulting	Page 76
Productivity consulting	Page 76
Education and training	Page 77
Agilent refurbished instruments	Page 552
Test system design and integration	Page 74
Channel Partners	Page 79

**"Agilent Technologies is the standard in terms of service that I measure every other company against."**

That's how Jim Giordano, a test engineer with Ethicon Endo-Surgery sums up his experience with Agilent service and support. "The number one reason we keep coming back to Agilent is the quality of the post-sales support. Agilent service adds tremendous value to the product."

### Resolution in hours, not months

Jim recently played phone tag with one vendor for two months trying to get their equipment to work as advertised. With Agilent, his expectations are on the order of hours. "An Agilent engineer even paged me on my way home from work one evening because he knew I needed an answer in a hurry. I called him back when I reached home, and we solved the problem that night."

### A superior solution: products plus people

"With Agilent, the combination of superior product design and superior customer service means that I can count on my equipment to provide nearly 100% up-time, making measurements that I have never had to question, with expert technical support people who help me make the most of the equipment capabilities in my applications. I consider Agilent to be a dotted-line member of every team I work on."

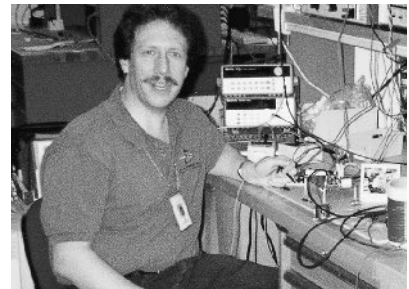

**Jim Giordano, Ethicon Endo-Surgery**



## Total support coverage for the life of your equipment

Our service and support promise is simple: maximize value, minimize risk and eliminate headaches. We work to fulfill this promise in three ways:

### You get what you paid for.

Our Promise means your equipment will meet its advertised performance and functionality.

### You get the support you need.

From presales advice through equipment disposal, Agilent engineers and technicians deliver the most comprehensive support in the industry. Support is available for at least five years beyond the production life of every Agilent instrument.

### Support costs are distributed fairly.

Delivering world-class support costs money; that's a fact of life. Your Advantage is an easy way to optimize your results by choosing from a menu of services that provide as much or as little as you need.

### Our Promise

When you're ready to choose new equipment, we'll help you with:

- Product information, including realistic performance specifications
- Product recommendations from experienced test engineers

When you use Agilent equipment, we'll make sure your equipment performs as promised, at no extra charge. Here's what you can expect:

- Operation verification to ensure your equipment is working properly
- Help with product operation
- Basic measurement assistance to help with specified capabilities
- Extensive self-help tools

We also have global instrument warranties by Agilent, worldwide.

### Your Advantage

Every application scenario is unique, so we offer a flexible set of services. You can purchase the services to fit your unique needs during every phase of ownership.

Whether you own a single Agilent instrument or a worldwide network of test systems, our engineering, repair and calibration services will keep you running at peak performance. By taking advantage of our consulting and design services, your team can focus on core tasks while we take care of the instrumentation. As with all our services, you select as much as or little as you need to fit your technical and financial requirements.

Our test specialists are ready to help at every phase of the system life cycle, from planning and design through installation, integration and operation. By applying these services in whatever way meets your unique needs, you'll achieve the full benefits of Agilent service and support:

- Reach peak productivity sooner
- Maximize the return on your investment
- Enjoy dependable measurement accuracy for the life of your system

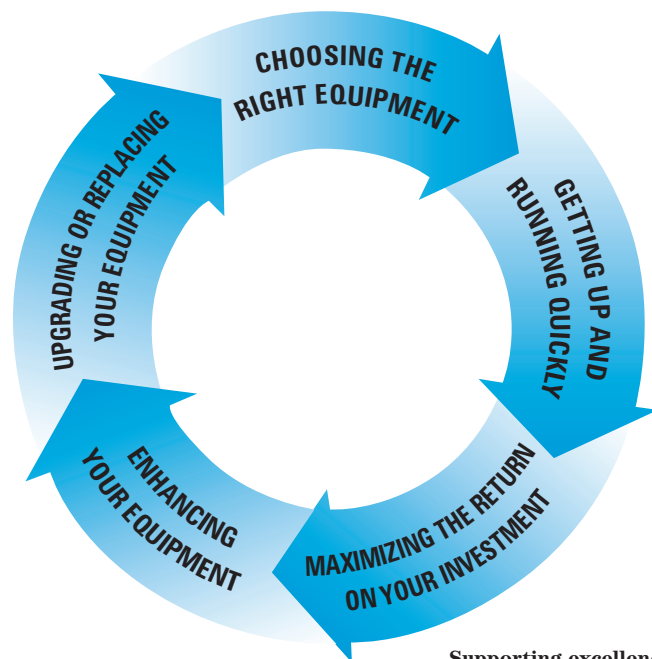

Supporting excellence in engineering throughout the lifecycle of your test system.

## Maximize uptime with peak product performance

No matter what kind of Agilent equipment you have, or how much you have, we offer dependable support that maximizes your uptime while making sure you're getting the optimum measurement quality. You can choose the level of support you need to balance costs and response times.

With customer service centers that span the globe, we can support your equipment wherever your work takes you. All major Agilent service centers are ISO 9000 registered and comply with major national and international metrology standards.

### Flexible choices

Agilent's product support programs are designed with flexibility to meet a variety of needs. Because support requirements vary widely from application to application and product to product, discuss your specific needs with an Agilent sales or support engineer.

For example, you can select either per-incident or contracted programs for both repair and calibration. Purchase Agilent support options when you buy new or Agilent refurbished equipment, or select from a variety of repair, calibration

and system support programs at any point after purchase.

### Repair services

Repair services are a great example of our flexible approach:

**Agilent support options** extend your warranty coverage (typically to three or five years, depending on the product).

**Standard Repair (STREP)** for one-time, fixed-price repairs outside of warranty. This alternative is a good choice for low-usage applications.

**One-year repair agreements** are usually the most cost-effective option for instruments in high-usage applications.

These repair programs assure your investment will be supported even after our standard warranties, which are some of the longest in the industry, expire.

For systems and selected instruments, we offer a variety of on-site support options, outlined on the following page.

### Calibration services

Agilent's instrument and system calibration services give you peace of mind by keeping your equipment operating with peak precision. All calibration measurements are traceable to national and international standards to ensure reliable, accurate results.

As with repair, calibration services are available in several programs to fit different needs. For individual instruments, returning the product to Agilent is often the most cost-effective choice. You can choose between per-incident calibrations and a calibration agreement for regularly scheduled calibration services. An expedited service for faster turnaround is also available.

For large instrument pools and systems, we offer on-site calibration programs to minimize costs and downtime.

**“Agilent was very responsive to our business needs and budget pressures. Overall, Agilent gave Netwave the exact level of quality service needed, when needed, and within budget.”**

Jerry Ulrich,  
Netwave Technologies

Type of Installation	Hardware Repair		Hardware Calibration		Software Support
	At Agilent	On-site	At Agilent	On-site	
Instruments: small number	Most cost effective	On selected instruments	Most cost effective	On selected instruments	Software and firmware support depends on product
Instruments: large number	Available on any scale	Usually most cost effective	Available on any scale	Usually most cost effective	Software and firmware support depends on product
Systems	Several levels of repair services		Several levels of calibration services		Response center support, software subscription and notification services
Mix of instruments and systems	Choose the best mix of support services for instruments and systems				

Agilent's flexible support programs adapt to any installation.

## On-site support services

We offer four levels of on-site system support, so you can choose the level of support you need for every key system:

### 1. Priority-Plus Support

The fastest response for mission-critical systems, with 24-hour on-site coverage 365 days a year. Four-hour response within 100 miles of selected Agilent support centers.

### 2. Priority Support

The best choice for important systems when substitute equipment is unavailable. On-site coverage from 8:00 a.m. to 9:00 p.m. Monday through Friday (except holidays). Four-hour response within 100 miles of Agilent support centers.

### 3. Next-Day Support

An economical choice when you have substitute equipment available. Provides next-day on-site coverage from 8:00 a.m. to 5:00 p.m., Monday through Friday (except holidays), within 100 miles of Agilent support centers.

### 4. Cooperative Support

An option for customers who maintain their own systems and need backup support for replacement parts, diagnostic tools and other services. Available on selected systems.

These support programs are available for a variety of Agilent systems:

- Board test systems
- Semiconductor test systems
- Telecom test products
- Datacom test products
- High-frequency design systems
- Digital design and debug systems
- VXI test systems
- Dynamic signal analyzers
- General-purpose test and measurement software (e.g., VEE)
- RF and microwave products
- Manufacturing functional test systems
- Electromagnetic compatibility products

## Response Center support

Agilent Response Centers offer system users a fast, easy way to solve a wide variety of operational problems.

One call to the Response Center puts you in contact with a system expert with access to our extensive database of system characteristics, known problems, workarounds, product performance data, and other information you need to stay productive.

Response Center contracts are available for one designated person on your staff or for multiple callers if you need broader support.

## Software update services

To ensure access to the latest system software and documentation, make sure a Software Update Subscription is part of your support strategy. These subscriptions are flexible, letting you buy only the materials and licenses needed for a specific application.

In addition to these updates, we provide notification services for mature products and hardware products with minimal software. These updates cover software, firmware and hardware upgrades, as well as servicing and support availability issues.

## Maximizing uptime at Artesyn Technologies

As one of the world's leading manufacturers of communications power systems, Hong Kong-based Artesyn Technologies relies on the availability and accuracy of more than 1,000 test and measurement instruments.

With both profitability and competition on the line, Artesyn knew it couldn't take a chance with calibration. The company worked with Agilent's Volume On-Site Calibration Services Team to devise a production and calibration schedule that has minimized disruptions and reduced calibration downtimes from days to mere hours.



Agilent's worldwide repair centers are equipped with state-of-the-art test equipment traceable to relevant standards.

**“Agilent really became a part of our team in developing the solution.**



**They didn't just sell us a box that we had to determine how to implement on our own.”**

**Dan Finch,  
C-Cor Electronics**



## Lucent Technologies helps networks feed bandwidth-hungry applications and services

Fiber optics have given telecom and datacom networks a huge capacity boost in recent years. Unfortunately, the Internet's appetite has grown even faster. In North America, for instance, all that new fiber is already running at 70 to 80 percent of capacity.

### Lucent WaveStar to the rescue

Network operators can respond in two ways: add more fiber, and make better use of the fiber they already have in place. Lucent Technologies' optical networking specialists are leading the way in this second effort, using a technology called Dense Wave Division Multiplexing (DWDM), that transmits multiple wavelengths of light simultaneously.

Lucent has deployed more than 2,400 DWDM systems already, and its powerful new 80-wavelength WaveStar™ OLS 400G boasts a maximum capacity of 3.2 terabits of voice, data and video per second.

### Teaming up to slice time-to-market

At the beginning of the product development cycle, Lucent committed to delivering the new WaveStar OLS 400G to its customers in under a year, significantly less than typical cycle times for a project of this magnitude. To help meet this ambitious goal, Lucent needed quick development of a test system, too. Moreover, Lucent's engineers needed a way to automatically test all 80 channels efficiently and effectively.

"In selecting a vendor for this test solution, we looked for a company that would really see us through our tight schedule," said Yassi Moghaddam, technical manager of

system test for Lucent Optical Networking Group. "We chose Agilent and were pleased that they followed through well every time, and sometimes came through even sooner than expected."

Agilent's test system developers and integrators worked in parallel with Lucent's development and test teams, freeing Lucent to focus on product development and meeting all of its high standards for product quality assurance.

"We optimize our processes to address each customer's needs, allowing them to take as much ownership of test-solution design and construction as they like," explains David Kent, operations manager of Agilent's Test Solutions Operations. "Lucent's team collaborated very closely with ours to draw up the system definition, and then we took over to complete hardware and software design and construction rapidly. It was an incredible team effort."

### The benefits of a common test platform

A cornerstone of the rapid test development strategy was a common test platform that helped Lucent leverage its convergent, cross-disciplinary efforts. As a result, time invested in one area shortened the cycles needed for other areas of development. For example, automation scripts and test routines created for the development stage were refined and promptly implemented during the system test phase.

Agilent's test solution, based on E1676B VXI OC-48c transceivers, lets Lucent examine each bit in a synchronous optical network (SONET) signal. To save time, Lucent's

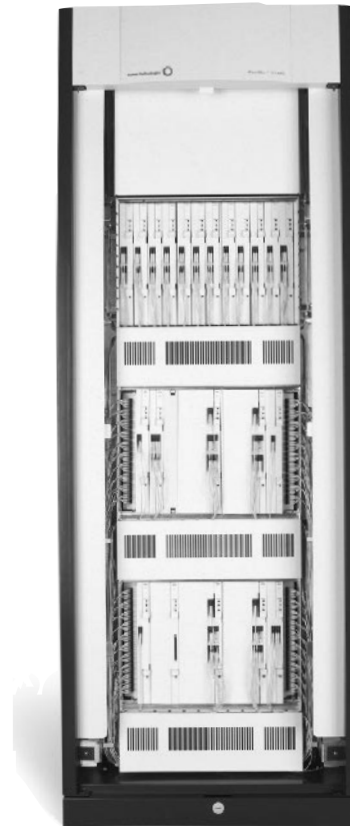

**Lucent Technologies WaveStar™ OLS 400G offers data rates up to 3.2 terabits per second to help ISPs and other network operators meet skyrocketing demand for capacity.**

engineers can perform each automated test remotely. Plus, Agilent's modular system approach makes it easy to add channels quickly, providing as much scalability as Lucent's development cycle required.

As Lucent continues its leadership in the competitive optical networking market, the company can continue to count on Agilent test systems to help deliver advanced networking solutions to those bandwidth-hungry customers.

## Integration services designed to meet your unique needs

In the world of automated test, no two projects and no two customers are alike. That's why every system integration project from Agilent is designed around your unique requirements and available resources:

### Level 1: Build-to-print test solutions

If your test engineers already have a plan in place, we can build a system to your design. We'll procure and coordinate the materials; then build, deliver, integrate and support the system.

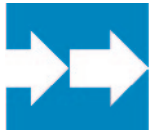

### Level 2: Collaborative test solution services

We'll work with your R&D, manufacturing, and field service teams to design, specify, and support an electronic test solution. Sharing the design and implementation tasks is often the best approach when product and test development need to progress simultaneously.



### Level 3: Turnkey test solution services

At this level, we'll cover the project from start to finish; from business needs analysis through field support for the life of the system. You get all the advantages of a professionally designed system without pulling staff away from other projects.



### Choosing Agilent as your development partner

Customers have used our integration services for hundreds of systems worldwide, enjoying significant business benefits:

- Getting products to market in less time
- Making better use of people and resources
- Cutting test costs
- Delivering better products through more complete and better focused testing

### A complete range of services and support

Our engineers and technicians are experienced in every phase of custom system development:

- Business and technical analysis
- Specification
- Test system design
- Software design and development
- Materials procurement
- Integration
- Documentation
- Training
- Delivery, installation and inspection
- Specialized test fixtures
- Long-term support
- Performance analysis
- System relocation

Our areas of concentrated expertise include wireless cell phone and infrastructure equipment, other communications equipment, satellite communication systems and aerospace/defense systems.

We can offer a unique combination of expertise that goes far beyond system integration. As the world's largest test and measurement company and one of the largest manufacturing firms, we understand electronic test from the ground up.

Moreover, our global design, support and delivery teams mean we can support you wherever your business takes you. After we've worked with you to deliver a final solution, we can quickly create multiple similar systems to deliver anywhere in the world.

### Controlling test at Allen-Bradley

When you manufacture more than 350,000 different products and product variations, from power devices and sensors to programmable controllers and quality management systems, keeping a lid on test costs can be a challenge. Moreover, Allen-Bradley wanted to streamline its test processes to simplify quality control, get new products to market faster and even conserve valuable floor space. The ability to test increasingly complex products was another major concern.

To meet all these goals, Allen-Bradley turned to Agilent's custom test specialists. The answer: a fully integrated solution based on a scaleable, common test architecture adaptable at more than two dozen sites worldwide. The results: a 10% reduction in test development costs, test execution times cut by as much as 50%, and development cycle times cut by as much as 12 weeks.



# Synchronizing planning and production at Henkel Waschmittel GmbH

The ecologically-oriented Henkel Group, a renowned specialist in applied chemistry, is dedicated to making people's lives easier, safer and more enjoyable. Pursuing these goals, the company has achieved leading positions in many areas of chemical production, including the European detergent and cosmetics markets, the worldwide market for metal surface treatment, and the manufacturing of adhesive products. Its Henkel Waschmittel GmbH division is a leading producer of detergents in liquid and powdered form.

## Responding to changing customer needs

In the early 1990s, the Henkel Group deployed SAP R/3 as a standard enterprise resource planning (ERP) application throughout its operations. To increase its responsiveness to customer requirements, the Henkel Group wanted to take the next step: plant-to-enterprise integration. Specific goals included synchronizing activities at the enterprise level with the process control level, achieving faster product delivery and reducing inventories.

## Linking processes across the enterprise

To achieve this next level of integration, Henkel Waschmittel called on Agilent Consulting in Germany. The company had several reasons for selecting Agilent, starting with Agilent's reputation for high quality products. Henkel Waschmittel's strong, decades-long relationship with Agilent was also a key factor. Plus, Agilent's size, stability and worldwide presence met the needs of their global operation.

Working with Agilent consultants, Henkel Waschmittel installed Agilent Real Time Applications

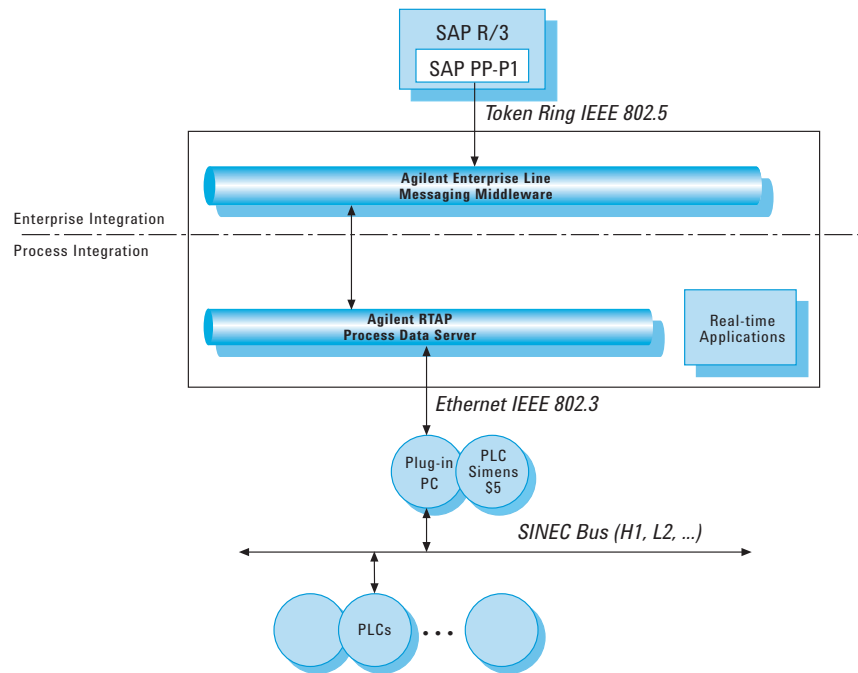

The custom Agilent systems installed at Henkel Waschmittel provide seamless data integration throughout the organization.

Platform (RTAP), a process data server that provides flexible, scalable and dependable data management.

Henkel Waschmittel installed four Agilent RTAP systems, with two at the Düsseldorf-Holthausen site and two at the Genthin site. At the ERP level, Consulting recommended installation of Enterprise Link at Henkel Düsseldorf-Holthausen. Enterprise Link is a certified messaging middleware that integrates SAP's R/3 system with real-time control systems.

Agilent integrated these systems into Henkel's existing IT environment, giving users easy access to online data from the central server via their Windows NT PCs. Production data of interest include temperature, viscosity, pH value, and the product level in each storage tank. The system can automatically generate reports for five major production areas: process information, opera-

tional data, failure reporting, production cycle times, and production quantities. This ready access to production information has increased the efficiency of decision making, problem detection and control.

Recipe management is also more efficient, thanks to the link between planning and production that Agilent RTAP provides.

## Leveraging the results

The team at Henkel Waschmittel GmbH is very pleased with the Agilent systems. Agilent Consulting helped Henkel overcome the challenges of a complex implementation, and results have exceeded expectations. Plans are already in place to install similar systems at other plants and to expand data correlation and fault detection features for more in-depth analysis.

## Knowledge is power: getting the right information at the right time



From a few hours of productivity assistance to a specialized design project, Agilent's engineers can help you make the most of your Agilent equipment while freeing your staff for key projects.

As a technical professional, you understand that having the right information at the right time can pay for itself many times over. Our test specialists stay on top of the latest developments in technologies, test techniques, measurement equipment and regulatory details.

### Is consulting or training the better choice for you?

If a measurement technique or other required knowledge represents an ongoing need, building the expertise in your organization through one of our many training courses (see the fol-

lowing page) is often the best answer. However, if your needs are short-term or highly specialized, it usually makes better economic sense to bring in a consultant while you focus on your core business needs. Our consulting services range from productivity assistance to advanced application solutions.

### Productivity assistance

Having an experienced user by your side can be a great help when you need to get up to speed quickly with your new Agilent equipment. A few hours of productivity assistance can

result in both better operating efficiency and higher quality measurements, thanks to our engineers' in-depth knowledge of Agilent equipment.

This productivity assistance can include just about any service your staff would find beneficial:

- Setting up, installing and initializing new systems
- Training users or production line operators
- Interfacing instruments, systems and workstations
- Configuring data management or presentation options

Productivity assistance is available in flexible increments, so you can buy as much or as little as you need, scheduled at your convenience.

### Application assistance

Our engineers are also available for more in-depth application support, from specialized measurements and troubleshooting to test process reviews and system optimization. Here are just a few of the application areas in which they've helped clients with unique test challenges:

- Phase noise measurements
- RF and microwave component design and testing
- Digital systems design and debugging
- Data acquisition and dynamic signal analysis
- Communication systems testing and troubleshooting
- Establishing measurement processes and procedures



## Take advantage of the latest test and measurement techniques

Agilent's industry and technology specific training services are a cost effective way to develop measurement expertise, from fundamental principles to the newest techniques in digital debugging or high-frequency design.

### Training based on your specialized requirements

As with all of our professional services, Agilent training courses can be adapted to fit your specific needs:

- In addition to classroom training, some of our most popular courses are available in self-paced, computer-based formats
- On-site delivery is available for nearly all instructor-led courses
- Custom training courses can be developed for specialized needs

### Learn more in less time

Agilent training courses employ both the latest in training technology and proven techniques for professional education:

- Our instructors understand your industry and speak your language; they know how to make the measurements you need to make
- Product and industry specialists, curriculum engineers, writers and instructors develop course materials as a team to ensure effective knowledge transfer
- Class sizes are limited, often ranging from 6-10 students
- Most courses include extensive hands-on experience
- Instruction includes the physics behind the measurements to help students apply their knowledge on the job

### Variety of courses

Training courses cover a wide range of test and measurement applications and industries:

- Automated testing using VEE
- Electromagnetic compatibility
- RF, analog and digital signal analysis and monitoring
- RF component and materials testing
- High-frequency design systems
- Datacom, telecom and mobile communications
- Board test systems
- Digital design and debugging, including embedded control systems
- Mixed signal, memory and processor testing

Course descriptions and schedules for each region of the world are available by calling Agilent or by visiting our training web site at:

[www.agilent.com/find/tmeducation](http://www.agilent.com/find/tmeducation)



Agilent's experienced instructors use the latest technologies and training approaches to maximize educational effectiveness.

## Building competitive advantage with an informed work force

A large wireless manufacturer in Singapore recently faced one of the biggest challenges a rapidly growing company can encounter: developing a trained work force fast enough to keep up with soaring demand.

The company turned to Agilent for help. Our wireless experts analyzed their immediate and long-term needs, then developed a custom curriculum around the needs of technicians, engineers and equipment operators. Ten on-site classes were established, with over 100 employees passing certification examinations. Ongoing curriculum enhancements help the staff stay up to speed on emerging technical developments.

## Support makes the difference in the fast-moving telecommunications market

From its base in the “Silicon Valley of Taiwan,” Microelectronics Technology, Inc. (MTI) has gained an international reputation as a supplier of communications components. Major manufacturers in the U.S. and Europe rely on MTI components for personal communication systems and other popular technology-driven products.

2

### Responding to competition by getting closer to customers

To respond to the high level of competition in these markets, MTI is working hard to foster close relationships with all its customers. According to Jason Chang, MTI’s Vice President of R&D, “Microwave communications technology is rapidly developing and the market is becoming more and more competitive. As a result, equipment suppliers and manufacturers have needed to establish better and closer relationships.”

To keep up with the the rapidly changing and complex technologies in the communications market, and to shorten product development cycles, MTI needed to make sure its R&D department was equipped with leading-edge design, development and test solutions.

### Cutting test development time with reprogrammable systems

In the past, MTI created hardware setup methods for its test procedures, in which each test setup could perform tests on only one particular component. Once the standard or component was changed, all the procedures had to be redone. The result was inevitable delays, delays that became unacceptable as customers demanded faster and faster turnaround times on new designs.

MTI needed a more flexible test system in R&D, along with a partner who could be relied upon to deliver and support such a system locally.

Prior to working with Agilent, MTI had been negotiating a purchase arrangement with another equipment supplier. As Mr. Chang explains, though, “We had an opportunity to meet with the Agilent people to talk about their new IQG signal test system. Based on that discussion, we suspended the other purchase order and evaluated the Agilent solution. The evaluation indicated the Agilent was a better match with MTI’s current needs in terms of pricing, performance, flexibility and support.”

### Supporting customers in fast-paced markets

William Wang, Director of MTI’s Special Electronics Department, believes the key factor affecting the decision was after-sales service and technical support. To cope with the fast pace of development in the microwave communication market, strong support is crucial during research and development.

Agilent’s test specialists in Taiwan wrote the software for the new system, so any problem that might arise could be solved by the programmers directly and efficiently.

The nature of Agilent’s support team in Taiwan was an important factor as well. Unlike some companies that deliver support through a single technician, Agilent Taiwan supports clients with an integrated team of more than 30 engineers.

The cooperation between MTI and Agilent over the years has established a mutual understanding that minimizes problems and quickly resolves those that do arise. MTI is looking forward to a continued partnership as the integration of the telecom, electronic media and computer businesses provides continued development opportunities and challenges.



From left to right: William W.S. Wang, MTI Director of Special Products; Jason L.C. Chang, MTI Vice President of R&D; Tony Chen, Agilent Consultant; and Lobo Wong, Agilent Senior Account Manager; stand before display of MTI communications products tested by Agilent test system.

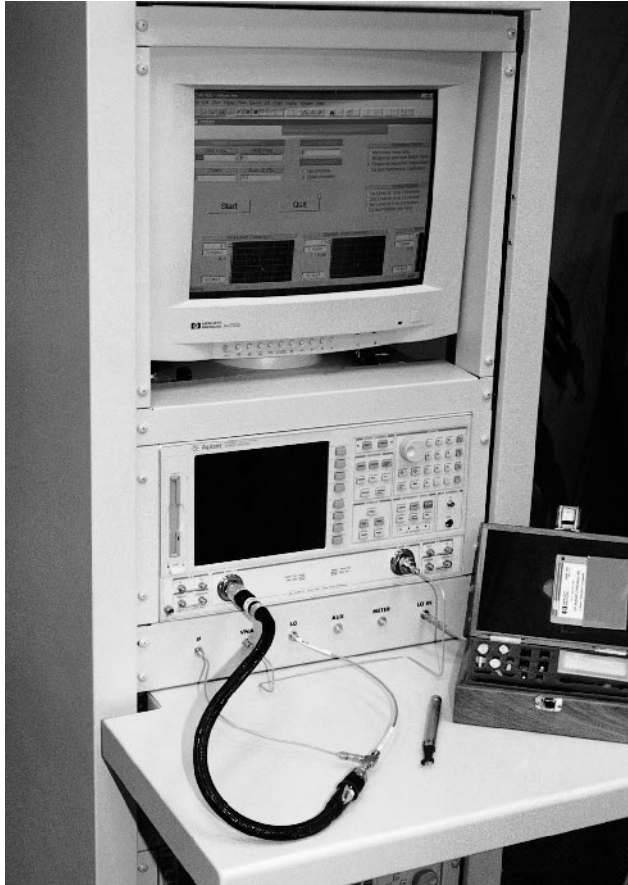

### Proven Solutions for Global Competitiveness

Agilent Technologies Test and Measurement instruments, as well as systems and related services, are used by engineers and scientists around the world to design, manufacture, operate, and repair advanced electronic equipment. Whether you're developing products, analyzing signals, or measuring product performance, you can rely on Agilent quality and reliability for accurate results. These results include a variety of product and process parameters—critical data that yields the information you need for smart engineering decisions.

### Partnering for Success

Agilent Technologies and its industry-leading Channel Partners are committed to delivering integrated test solutions to help you reduce your time-to-market and increase your engineering productivity. These test solutions include high-performance measurement platforms, software applications, and support.

#### Custom Solution Integration Partners

To complement our test system design and implementation services, Agilent has formed relationships with other test systems integrators as part of our Custom Solution Integration Partner Program. Together with these general integration partners, we can offer test systems solutions in a broad spectrum of applications.

#### Complementary Solution Providers

There are some applications where Agilent resources and products are only a part of the total solution. Often, these applications require additional capabilities offered by our Complementary Solution Providers. These companies bring quality applications, solutions expertise, and industry knowledge to the solution equation. Together, we deliver industry-focused solutions in the following application areas are just some examples:

- Antenna test
- Battery/Power supply test
- Calibration
- Data acquisition
- Electrical system component test
- Electronic/Electrical test
- Electronic component test
- Electronic functional test
- Electronic sub-assembly test
- High speed digital test
- Jet/Turbine engine test
- Microwave semiconductor test
- Mechanical functional test
- Noise, vibration, and harshness
- Piston engine test
- RF/MW device characterization
- Rotating machinery analysis

For more information about these solutions, visit our Channel Partner Solutions Portfolio web site: [www.agilent.com/find/tmpartners](http://www.agilent.com/find/tmpartners)



## Agilent's web site: Get news, updated product and support information, and more, 24 hours a day.

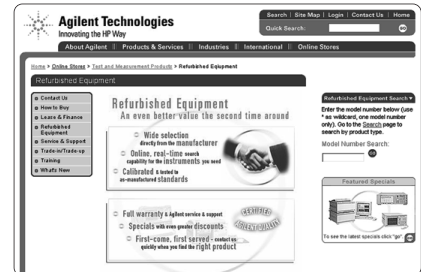
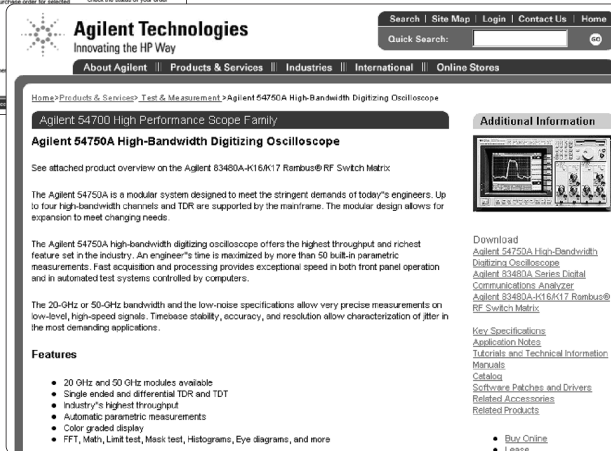

### Resources Available Online

- Product and support information more easily with helpful navigation aids and improved web pages that make it easier to access application notes, product overviews, technical details, frequently asked questions, manuals, software, news releases, education course descriptions and schedules, and much more.
- Updated comparison data and evaluation guides/tools that facilitate product selections
- Helpful application notes, downloadable interactive application notes, tutorials, online models, and other learning and problem-solving material
- Quick access to customer support services
- Information on recommended replacements for discontinued products
- Information in your local language\*
- The latest information on the status of your Agilent test and measurement order

### Take Action

- Selected Agilent products—including scopes, logic analyzers, EDA software, multimeters, data acquisition products, signal sources, counters, power supplies, and more\*
- Refurbished instruments\*
- Accessories\*
- Replacement parts\*

For more information on the test and measurement features, resources, and services available on Agilent's web site, see page 3.

Use our online test and measurement resources and services often!  
[www.agilent.com/find/tmc](http://www.agilent.com/find/tmc)

\*Availability of this feature may be limited; an expansion program is ongoing. Online purchases require a credit card.

For best results, view the Agilent web site with Microsoft's Internet Explorer browser.



<b>Instrument to Network Connectivity Initiative</b>	<b>82</b>
<b>Communications EDA Software</b>	<b>84</b>
<b>Test Software</b>	<b>86</b>
<b>MMS Products</b>	<b>90</b>
<i>See also</i> Consulting Services 76	
<b>VXibus Products</b>	<b>93</b>
<i>See also</i> Test Software 86 System Switches 97 Data Acquisition Systems 530 Consulting Services 76	
<b>System Switches</b>	<b>97</b>
<i>See also</i> VXibus Products 93	
<b>Interface Products</b>	<b>101</b>
<b>Additional Literature</b>	<b>103</b>

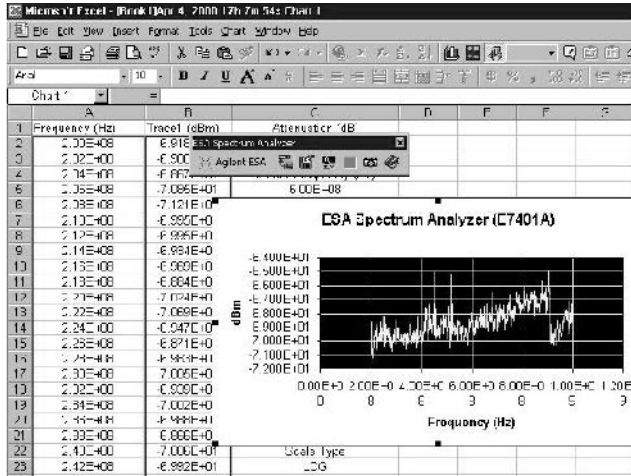

Microsoft Excel spreadsheet, with data imported from an Agilent ESA spectrum analyzer, showing the add-in toolbar feature and a waveform screen capture from the instrument.

### Connecting PCs to Instruments

Agilent offers a set of connectivity tools that enable you to quickly and easily move data from your Agilent instruments to your PC. Whether you are an experienced programmer or would prefer not to program at all, our connectivity solution is designed to give you a high-level of instrument control using software applications that you are probably already using on your PC.

### A Simple Toolbar Add-in for Excel and Word

Agilent's solution provides an easy-to-use toolbar that enables you to save instrument settings to file and retrieve them for later use, insert instrument readings into Microsoft Excel or Microsoft Word, and log instrument readings in Excel. Once installed, the toolbar is automatically loaded and operates just like any other tool bar in these applications.

### Connectivity Strategy

The connectivity technologies developed by Agilent provide you with a significant competitive advantage. Agilent is committed to the value added by built-in connectivity capabilities included with our test and measurement equipment such that we have dedicated full-time resources chartered with the following activities:

- Exploit the macro-trend toward computer-based instruments by enabling more instrument/measurement functionality in software while reducing complexity and cost of hardware. By reducing the complexity of the hardware, and programming more features and functions into the software, Agilent is making it easier to use our test and measurement equipment.
- Create value and differentiation by making it faster and easier to create measurements and test by focusing on ease-of-use, ease-of-learning by using familiar environments and paradigms. You want to be able to use your equipment in familiar environments such as web browsers, Microsoft applications, MATLAB, Visual Studio, and Agilent VEE.
- Use a software component strategy and a suite of new services to deliver on the vision. Component technology is a key enabler for providing customer value and improves internal efficiencies.
- Capitalize on key Agilent competencies by providing ways to create, encapsulate, and deliver "measurement science" and "test technology" in software and services.
- Provide unique and compelling value by easing the migration of measurements across the lifecycle of our customer's products. Working with you, our partner, we provide solutions for today while developing the next generation of technologies, tools, and methods.

### Built-in Software Features

With our connectivity test and measurement solutions you can move instrument data to your PC-based applications such as MS Office, visualize, analyze, and print your test and measurement results. And, if you are developing test programs for automated test systems, Agilent's connectivity products work seamlessly with your standards-based development environment, ensuring the fastest time to test.

Agilent Technologies instruments work effortlessly and seamlessly with the use of an integrated toolbar—access to your instrument's data and graphics is only a few mouse-clicks away. We provide a faster and easier way to create reports and analyze measurement results by focusing on ease-of-use and ease-of-learning while using familiar environments such as:

- Toolbars in MS Office provide direct access to instrument data, screen shots and instrument setups.
- Active X controls and COM driver objects
- On-line Help

Programming Examples or little programming of instrumentation

- Minimal test automation needs
- Accurate, full-featured instruments
- Interactive environment for experimentation
- Analysis and visualization tools to aid in interpretation of measurement results
- Better understand and manage the transition of a design from the "virtual" world to the "real" world
- Maintenance of a lab notebook, report generation, design documentation

### Linking Your Equipment

Agilent Technologies believes you should be able to access and monitor your instruments at anytime and at anyplace. Agilent accomplishes this by basing its I/O strategy on established computer I/O standards, such as Ethernet and IEEE 1394 while supporting legacy test and measurement standards such as IEEE 488.

As an R&D Engineer, you need to easily get data from your instruments into your PC applications (e.g., Excel, Word, and technical analysis applications) without programming.

You will be able to use the same I/O connector and cable to connect your instrument to your PC as you do for your other PC peripherals.

- On the desktop (Serial)
- Within a system (GPIB)
- Throughout the enterprise (LAN)

Easily connect to your instrument from your favorite choice of programming environments.

- Measurement Specific (i.e., Agilent VEE)
- General Purpose (i.e., Microsoft Visual Studio)

### Integrated with Your Programming Environment

Agilent Technologies helps you accelerate your measurement insight in design verification, manufacturing test, process control, and data acquisition by providing software tools in the environment of choice using the familiar programming for each task and accelerating flexible deployment.

### Minimum System Requirements

#### PC Operating System Requirements:

Windows 95 or Windows 98  
 Windows NT 4.0 SP 4 or higher, Windows 2000  
 Pentium-90  
 32 MB RAM  
 20 MB free disk space

#### Environments Supported

Applications:  
 Microsoft Excel 97, Excel 2000  
 Microsoft Word 97, Word 2000

#### Software Development

Visual Basic 5.0/6.0  
 VBA 5.0/6.0  
 Agilent VEE 5.0 or greater  
 Visual C/C++ 5.0/6.0

### Driver Standards

IVI, or Interchangeable Virtual Instruments, is a new instrument driver standard based on the COM (Component Object Model) computer standard. The IVI Foundation, an open consortium of companies chartered with defining software standards for instrument interchangeability, is developing IVI Open Architecture, which will give you the ability to use IVI drivers in the development environment of your choice. By defining a standard instrument driver model that enables you to swap instruments with reduced software changes, the IVI Foundation members believe that significant savings in time and money will result:

- Test software on long-life test systems can more easily be updated when instruments become obsolete.
- A single test software system can be deployed on test systems with different instrument hardware to maximize use of existing resources.
- Test code developed in R&D labs can be ported to different instruments in the production environment. In situations where drivers alone cannot provide the required level of interchangeability, IVI-MSS components can provide more robust interchangeability.

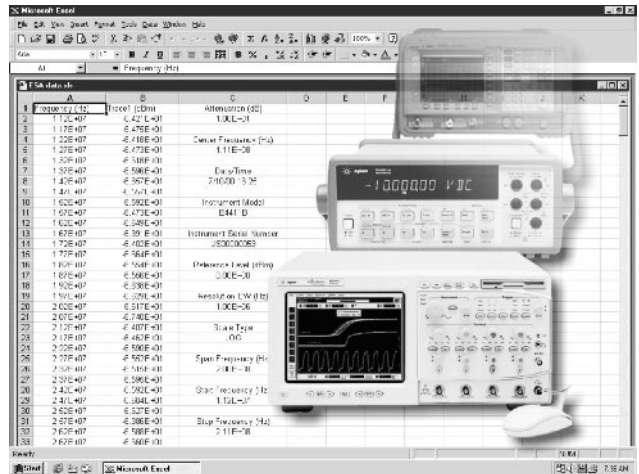

### 3 Types of IVI Standards:

- IVI-Open Architecture—The foundation needed to create driver.
- Classes—define the category: API (Application Programming Interface) for type of instrument.
- IVI-MSS Solution—In situations where drivers alone cannot provide the required level of interchangeability, IVI-MSS components can provide more robust interchangeability.
- Critical production test systems can remain online when instruments malfunction or need recalibrating.

Once loaded, the IVI instrument drivers can be used to access "home base" applications, which include Visual Basic, Visual C++, Microsoft Office, Agilent's VEE, and MathWorks MATLAB as well as browsers.

For more information, visit our web site at: [www.agilent.com/find/gp](http://www.agilent.com/find/gp)

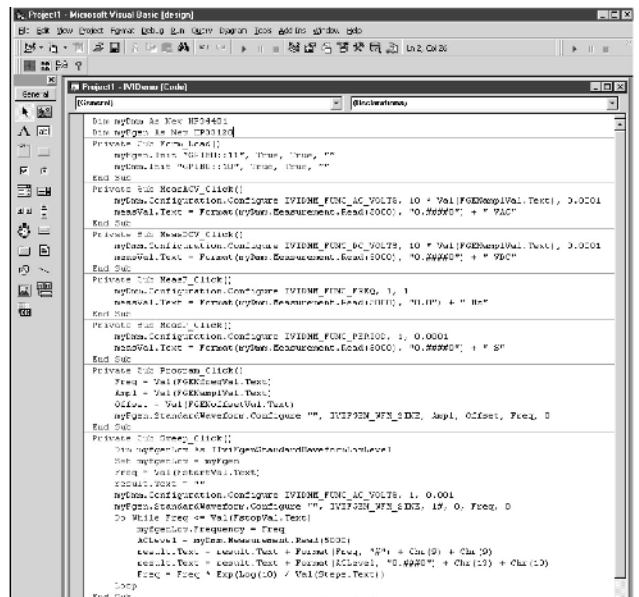

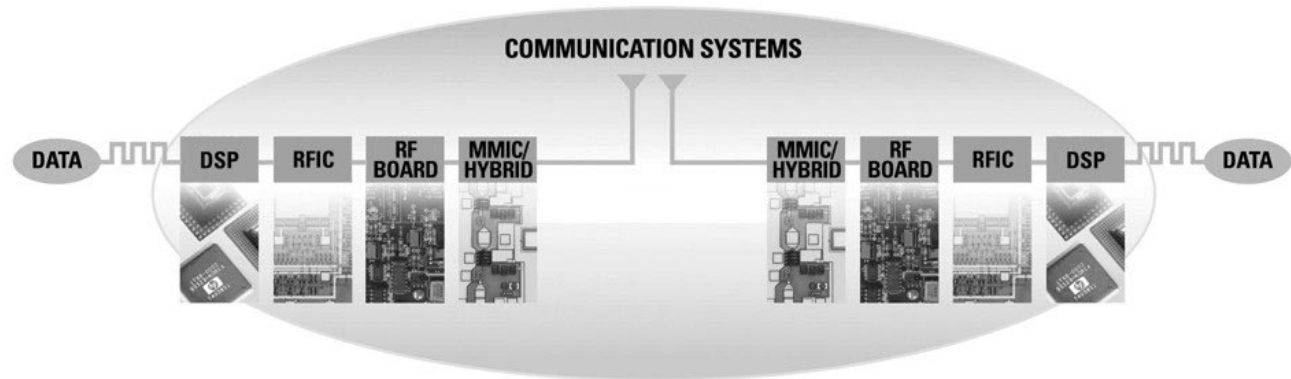

## Advanced Design System—A Unified Environment for Communication Signal Path Design

3

The challenge of communications design is to shorten time to market, while making better, smaller, faster products. Agilent EEsof EDA's Advanced Design System simulates the entire communications signal path for today's and tomorrow's next generation communications product design. This unique solution integrates proven RF, DSP, and electromagnetic simulators into a single, flexible design environment.

### Combining Proven Technology with New Innovation

Advanced Design System provides new DSP design and synthesis technologies and significant new design capabilities for RF, microwave, and RFIC, all integrated into one efficient, flexible design solution. The integration of RF and DSP analysis engines allows real-time co-simulation and is unique in the EDA industry. The integration of multi-discipline design tools into a single environment and database eliminates the barriers caused by separate processes and allows design teams to easily examine tradeoffs and optimize design margins. This design environment is available for both PC and UNIX platforms. The PC version can be run on a modern laptop, creating a more flexible design environment.

### Bridging the Gap Between Simulation Technology and Applications

To answer the many challenges that communication design engineers face today, Agilent EEsof EDA offers a significant new direction and approach for the communications EDA industry. Agilent EEsof EDA now bridges the gap between simulation technology—software simulation tools and real-world design—your applications. Breakthroughs in simulation technology and rapid expansion of new products like DesignGuides, synthesis tools, Design Libraries in Advanced Design System, and application-oriented education significantly reduces design time, increases productivity and efficiency, and ultimately gives designers an edge over the competition.

### System Design

The Advanced Design System top-level design solution, Communication Systems Designer, offers unprecedented speed and accuracy in mixed DSP/RF system simulation.

Communication System Designer's RF system simulation capability is enhanced with an extremely fast harmonic balance simulator that allows engineers to compute full budget simulations on any RF topology. Included are measurements for dozens of system-level

parameters such as incident power, noise figure, third-order products, signal-to-noise ratio (SNR), noise bandwidth, and more. RF system simulation analysis of control circuits such as phase-locked loops and automatic gain control loops allows engineers new freedom to experiment with innovative approaches to their designs. An instrument server lets users link to RF and communication measurement instrumentation.

For DSP design, Communication System Designer has a new signal-processing engine that allows processing of data in vector and matrix form. Included are over 300 DSP models, Bit Error Rate (BER) testers that have both Monte Carlo prediction and a faster variance reduction algorithm, and advanced post-processing such as FFT, correlation, cumulative distribution function (CDF), probability distribution function (PDF), and complex math functions. The optional link to MATLAB has a user-friendly C-code interface.

Communication System Designer also offers optional Design Libraries for wireless standards such as EDGE, cdma2000, W-CDMA/3GPP, GSM, and CDMA.

### RFIC Design

Circuit simulation technology in Advanced Design System features dramatic enhancements resulting from patented new technologies. RFIC Designer offers integrated RFIC simulation technologies that provide the most efficient and accurate verification of RFIC performance against modern digital wireless standards specifications, such as adjacent channel power ratio (ACPR) and error vector magnitude (EVM) of CDMA systems.

Co-simulation of RF and DSP interactions in RFIC chipsets ensures on-spec performance without costly iterations.

Agilent EEsof EDA provides services to integrate Advanced Design System into design flows that use Cadence and Mentor Graphics products.

### DSP Design and Synthesis

Digital Signal Processing is a vital part of today's communications designs. Advanced Design System addresses this need with the inclusion of two new DSP tools: DSP Designer and DSP Synthesis. These two products were developed especially to help DSP design engineers create and evaluate baseband designs.

The Agilent Ptolemy simulation engine facilitates co-simulation of time, frequency, and data-flow technologies and significantly expands the DSP development capability for mixed RF/analog/DSP communications projects. Agilent EEsof EDA is the only EDA vendor to deliver RF/DSP co-simulation capability within a complete design environment.

DSP Synthesis offers powerful capabilities to help both DSP and IC designers move quickly from a system-level design to implementation, which improves productivity and reduces development cost.



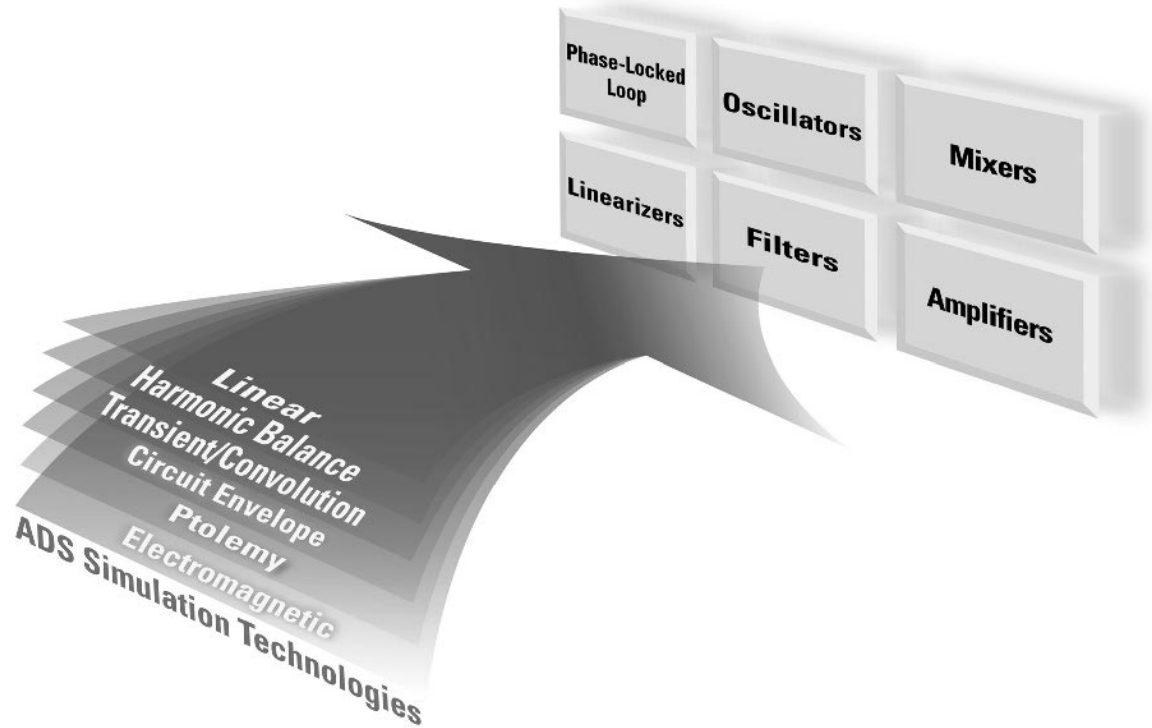

DesignGuides apply the breadth of Advanced Design System simulation technologies to a wide variety of applications.

### Microwave Circuit Design

For traditional design, the microwave circuit designer benefits from the integration of system, circuit, and electromagnetic simulation, as well as full schematic and layout, microwave hybrid, and MMIC design tools. Microwave Circuit Designer includes a Design Rule Checker with an easy-to-use, rules-writing interface. A Graphic Cell Compiler allows the designer to create footprints graphically without programming and to compile them into AEL (Application Extension Language) macro language, providing layout enhancements for ground-plane management and better trace handling.

### Planar and 3D EM Design

Electromagnetic design and simulation tools are an integral part of the RF and microwave design process.

Agilent HFSS Designer provides accurate EM modeling of arbitrarily shaped passive 3D structures. Agilent Momentum is a planar EM simulator that allows RF and microwave designers to significantly expand the range and accuracy of their passive circuits. Optimization technology provides design as well as analysis capabilities for both planar and 3D structures.

### RF Board Design

Whether a cellular/PCS phone, pager, or next generation wireless product, today's communications products ultimately are built using PCB technology. RF Board Designer provides design, simulation, and analysis capabilities for a complete top-down design from system to circuit and physical design, all within a single integrated environment.

### Libraries

Part of Advanced Design System's power lies in its extensive libraries. Advanced Design System provides over 100,000 models for popular devices from numerous vendors. Design Libraries for W-CDMA, EDGE, GSM, and 3GPP standards provide pre-built behavioral models, simulation systems, and test benches that speed up new product development.

### Device Modeling Systems

Agilent EEs of EDA Device Modeling Systems are the first total systems specifically dedicated to active device modeling. They combine parameter extraction and test hardware with IC-CAP modeling software. Industry-standard SPICE models as well as Agilent EEs of EDA high-frequency models are available for FET, HEMT, BJT, MOS, diode, and thin-film devices.

The IC-CAP software provides the total framework environment in which standard, modified, or fully custom device models may be extracted or generated. Specific models include Agilent Root FET and MOS Model Generators, as well as FET, BJT, HEMT, diode, and thin-film models.

### Key Literature

Advanced Design System Brochure, p/n 5966-2870E  
 What's New in Advanced Design System 1. 3, p/n 5968-8754E  
 RF Board Designer Brochure, p/n 5966-2872E  
 RFIC Designer Brochure, p/n 5966-2871E  
 Microwave Circuit Designer, p/n 5966-0671E  
 High-Frequency Structure Simulator Brochure, p/n 5967-5846E  
 Communication Systems Designer Brochure, p/n 5966-0670E  
 DSP Designer Brochure, p/n 5966-2869E  
 DesignGuides Folder, p/n 5968-8157E  
 Device Modeling Systems, p/n 5968-6082E

### Support

A complete line of support products includes software updates and telephone technical support. Please contact the Agilent Test & Measurement Call Center in your region for more details.

### Ordering Information

**E8900** Advanced Design System, Agilent 85180A High-Frequency Structure Simulator, and the 85122A Precision Modeling System come in a number of configurations and bundles.

For more information, please call the Agilent Test & Measurement Call Center at 1-800-452-4844 (in North America), or refer to our web site: [www.agilent.com/eesof-eda](http://www.agilent.com/eesof-eda)

- For manufacturing functional test
- Version 4.1 for standalone applications
- Configuration tools for rapid system integration
- Available on Windows NT and Windows 2000
- Agilent Intelligent Test compatible

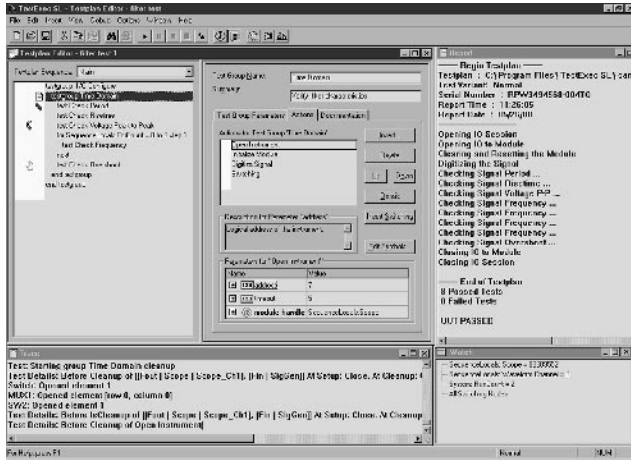

Test Exec SL Testplan Editor

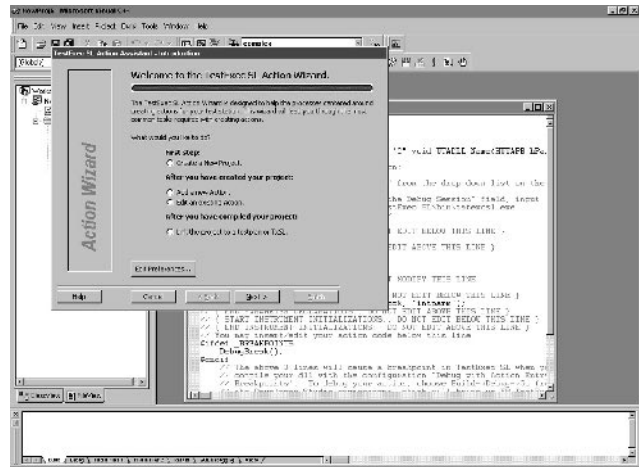

Test Exec SL Action Wizard plug-in for Microsoft Visual Studio

### TestExec SL



TestExec SL is a fully featured test executive platform that offers both a robust system development environment and a simple-to-use but fast execution engine. TestExec SL speeds time to market based on rapid test plan development and integration with a software framework for re-use. It also helps improve production capacity with tools that profile test execution and enable multiple-UUT testing.

#### Rapid Test Plan Development

TestExec SL features a complete software framework for developing and debugging even the most complex test plans.

- Test plans use a structured hierarchy for logical grouping and association of test groups, tests, and actions.
- Test sequencing supports conditional flow control.
- Tests and actions can be developed in language of choice (C++, VEE, LabVIEW, etc).
- Action wizard utility generates DLL-style C code to integrate user-defined actions.
- Debug environment includes breakpoint settings and watch and trace windows.
- Framework for software reuse includes facilities for managing action libraries.
- Test plan compatible with all earlier embedded versions of TestExec SL.

#### Usability Tools for High Performance

TestExec SL has many valuable time-saving integration tools that help test engineers take some of the pain out of system integration.

- Throughput multiplier enables hardware-sharing multiple-UUT testing without the need for custom software.
- Switch manager helps manage the complex topologies between instrument and UUT.
- Configurable data logging exports data in CSV ASCII, XML and Agilent 3070 formats.
- Test profiler compiles and displays key test performance results for optimal system tuning.
- Run-time user interface customization supports Visual Basic and ActiveX.

### Test Development Environments Supported

- Microsoft Visual Studio (C, C++, and Visual Basic)
- Agilent VEE Pro
- BASIC for Windows
- National Instruments LabVIEW
- National Instruments LabWindows/CVI

### Compatible Instrument Drivers

- C/C++ DLL-style or COM instrument drivers
- VXIplug&play devices
- Message-based instruments including IEEE 488.2 instruments
- Drivers included with VEE, LabVIEW, or LabWindows/CVI

### Minimum System Requirements

- 300 MHz Pentium-class PC
- 64 MB available RAM
- 35 MB disk storage minimum
- Microsoft Windows NT 4.0 or Windows 2000

### Evaluation Copy

The easiest way to appreciate the extensive capabilities of TestExec SL is to try it. The evaluation copy lets you explore the entire product and includes a comprehensive walkthrough tutorial. To download an evaluation copy of version 4.1 of TestExec SL or to request it on CD-ROM (p/n 5980-1487E), visit our web site at: [www.agilent.com/find/testexec](http://www.agilent.com/find/testexec)

### Worldwide Support

With TestExec SL, you have access to Agilent's worldwide resources for startup assistance, phone support, training, consulting, and update services. Telephone technical support is offered worldwide 24/7 through our 4 regional response centers with 4 hour response time.

### Key Literature

TestExec SL Product Data Sheet, p/n 5980-1240E or visit our web site at [www.agilent.com/find/testexec](http://www.agilent.com/find/testexec)

### Ordering Information

- E2011E TestExec SL Version 4.1
- Opt US1 Development License
- Opt ROL Run-Time only license
- Opt AGE Upgrade from version 3.2 or earlier
- Opt H00 Annual Site support contract
- Opt P00 Add caller to support contract
- Opt 24C TestExec SL Intro Training (2 days)
- Opt 24D TestExec SL Developer Training (3 days)



Indicates QuickShip availability

- The easy graphical programming environment
- Fast measurement analysis results

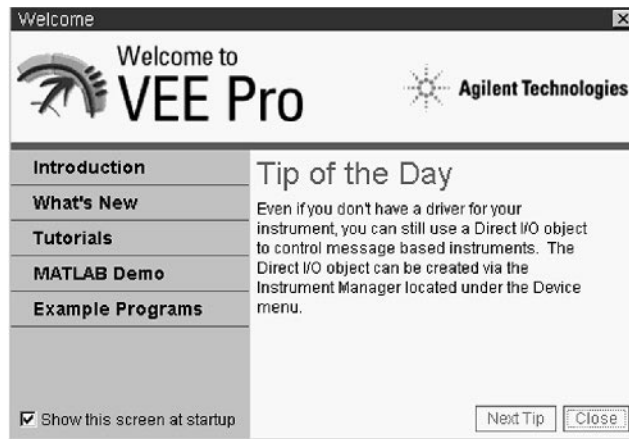

**VEE Pro and VEE OneLab**



**Measurements to Minds**

Agilent Technologies is in the business of connecting measurements to minds to market. The Agilent VEE software family builds upon the popularity of HP VEE 5.0 with its industry-standard approach to math analysis, visualization, and signal processing. It integrates two separate software packages into a single graphical environment that handles both measurements/data collecting and spreadsheet/math analysis. You actually get the built-in power of MATLAB Script and the Signal Processing Toolkit from The MathWorks. These capabilities are embedded within VEE at no extra charge. With VEE 6.0, tests are developed faster, results are analyzed more easily, understanding is increased, and data analysis is greatly enhanced. VEE makes it possible within your familiar “home base” environment, leveraging the solutions you have in place today.

**VEE Is Graphical**

VEE is an award-winning, uniquely productive, two-dimensional programming environment. To create a program, you choose high-level graphical objects from the menu and connect them with wires (no more low-level icons to represent each textual line of code). The wire connections help specify functionality and sequence in intuitive block diagrams. You program at a higher, task-oriented level using built-in scientific and engineering routines. VEE jumpstarts your programming effort, and maximizes the 2-D programming space for faster measurement analysis results.

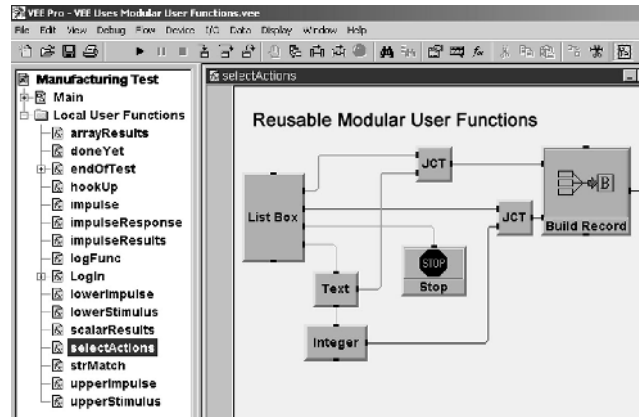

**VEE Is Efficient**

VEE's is self-documenting: it illustrates the connections between individual objects and the wires that join them to create a program. Where appropriate, many objects (such as MATLAB objects) also include powerful textual code within the object itself. Objects include graphs, displays, advanced math, signal processing, and more. The objects can be built into reusable, modular UserFunctions (or UFs), making it easy to configure and reconfigure programs. Events between objects can be managed by special sequencing wires or objects. Since execution of code is determined by dataflow through wires, VEE can multitask by running multiple execution threads and UFs in parallel.

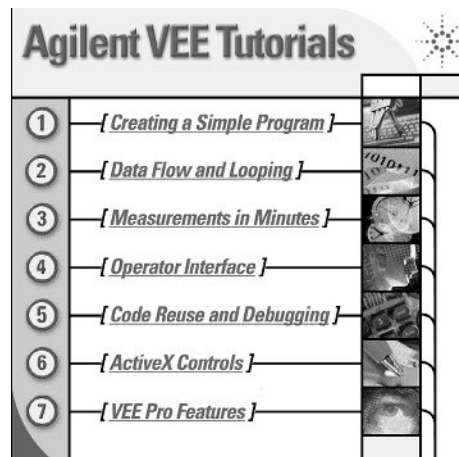

**VEE Is Highly Usable**

- Includes seven multimedia built-in tutorials (for Windows).
- Converts automatically among 16 data types without extra programming.
- Opens welcome windows automatically for the VEE example directory and MATLAB demos.
- Provides context-sensitive tips and help.

E2120G  
E2111G  
E2117G  
E2119G  
E2123G  
H2327G  
H2328G  
82345G  
82351G  
82353G

3

E2120G  
E2111G  
E2117G  
E2119G  
E2123G  
H2327G  
H2328G  
82345G  
82351G  
82353G

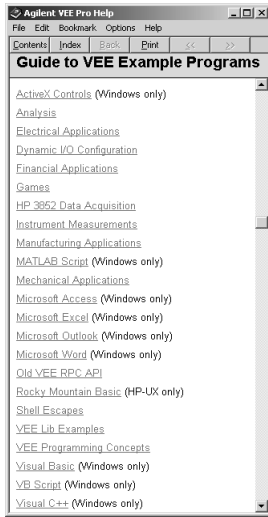

### VEE is Multi-Language Environment

As an open graphical environment, VEE works with leading products across all market segments. It accepts data from any vendor's instrument or PC card. It supports leading applications such as Microsoft Excel and Word, The MathWorks MATLAB, Microsoft Internet Explorer, and Netscape Navigator. It supports popular programming languages including Visual Basic, C, and Visual C++. It works with manufacturing equipment via ActiveX, including surface-mount machines and robots. Agilent VEE can be used as a standalone solution or it can deliver measurement analysis results from custom in-house solutions. It becomes part of your environment without changing the way you do business.

### VEE Is Measurement Smart

- Program the properties of your instruments quickly, easily, graphically.
- Take any measurement and control any PC card or instrument from any vendor.
- Use over 500 National Instruments LabWindows/CVI drivers.
- Create runtime executables easily with embedded I/O configuration, and distribute the programs, at no extra charge.
- Verify instrument addresses and other parameters automatically at runtime.
- Troubleshoot instrument timeouts and other errors automatically.

### VEE Expanded Family: VEE Pro and VEE OneLab

With the introduction of the Agilent VEE 6.0 family, a new member is added—VEE OneLab 6.0. VEE OneLab creates an unprecedented industry price/performance point for individual engineers and scientists programming measurement solutions. VEE Pro 6.0 is designed for large projects using complex measurements and includes web enablement, ability to create unlimited RunTime versions, interprocess communication, and advanced debugging and documentation tools.

### Minimum System Requirements

- PC with a Pentium 120 MHz processor; 266 MHz Pentium II or higher recommended
- Microsoft Windows 95, Windows 98, Windows NT 4.0, or Windows 2000 operating system
- 24 MB RAM with Windows 95/98, 48 MB RAM with Windows NT/Windows 2000
- Hard disk free space: 25 MB minimum (without MATLAB); 60 MB with MATLAB and tutorials
- CD-ROM drive

### Free Evaluation Copy

Check out our web site: [www.agilent.com/find/vee](http://www.agilent.com/find/vee)

### Worldwide Service and Support

With Agilent VEE, you have access to Agilent's worldwide resources for start-up assistance, telephone support, training classes, and update services. Additionally, through contracts with leading PC plug-in card suppliers, Agilent provides total solutions for test, measurement, and data acquisition. Many companies offer hardware/software solutions based on Agilent VEE.

Join the Agilent VEE electronic users group. Sign up through the Agilent VEE web site and get assistance on using the Agilent VEE from experts around the world: [www.agilent.com/find/vee](http://www.agilent.com/find/vee)

### Ordering Information

#### VEE Pro 6.0

Model Number	Option No.
VEE Pro 6.0 for Windows	E2120G
VEE Pro 6.0 ISA GPIB Automation Kit	82345G
VEE Pro 6.0 PCI GPIB Automation Kit	82351G
VEE Pro 6.0 HP-UX 10.2	E2111G
VEE Pro 6.0 Ten-Seat Site License* Previous purchase credit per copy (up to five maximum)	E2119G CDT
VEE Pro 6.0 Site License Upgrade	E2119G # AGE
VEE Pro 6.0 Faculty	H2327G # WN1
VEE Pro 6.0 Faculty +GPIB	H2327G # PCN
VEE Pro 6.0 Upgrade from 3.2 or later	E2120G # UP1

\*Quantity discounts available †After 50 discount

#### VEE OneLab 6.0

Model Number	Option No.
VEE OneLab for Windows	E2123G
VEE OneLab ISA GPIB Kit	82353G
VEE OneLab Faculty	H2328G # WN1
VEE OneLab Faculty + GPIB	H2328G # PCN
VEE OneLab Upgrade to VEE Pro	E2120G # LAB

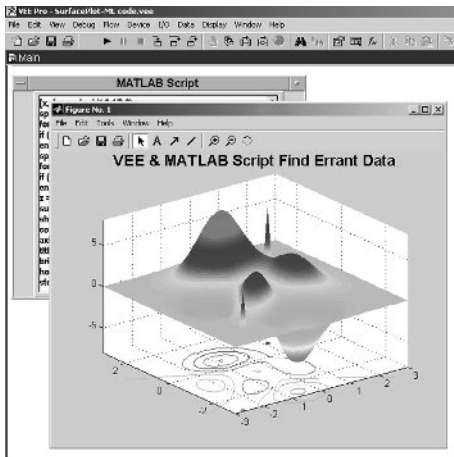

### Embedded MATLAB Script Yields Built-In Analysis

The power of MATLAB Script and the Signal Processing Toolkit embedded within VEE, (from The Mathworks) delivers unprecedented analysis and visualization capabilities in a single graphical environment. You get hundreds of functions with VEE, plus the 500 most popular MATLAB functions preprogrammed as one-click VEE objects, including:

- Numeric and symbolic computation, including linear algebra and matrix computation, Fourier and statistical analysis, differential equation solving, matrix manipulation, trigonometric and other math operations.
- Data analysis, manipulation and reduction.
- Volume visualization of scalars and vectors, multiple lighting sources, camera-based viewing.
- Engineering and scientific graphics: 2-D and 3-D displays; triangular and gridded data; waterfall diagrams; and quiver, ribbon, scatter, bar, pie, and stem plots.
- Signal processing functions including signal and linear system models, analog filter design, FIR and IIR digital filter design, spectrum estimation, and time-series modeling

### VEE Is Customizable

You don't have to create a front panel for your VEE program, but if you want to create a user interface without access to your code, you simply add the objects and UserFunctions to your front panel. VEE's compiler generates optimized code that can be further enhanced with its built-in Profiler. The Profiler allows you to quickly analyze critical sections of code to save development time when fine-tuning your programs. When you're ready to distribute your VEE program, you can automatically create a runtime executable directly from the menu. You get unlimited runtime with VEE—distribute your programs at no extra charge.



- New Windows-style editor
- New Windows graphical user interface
- New integrated debugger speeds development
- Easy to learn/Use textual programming language
- Powerful graphic commands to display data

E2060D

3

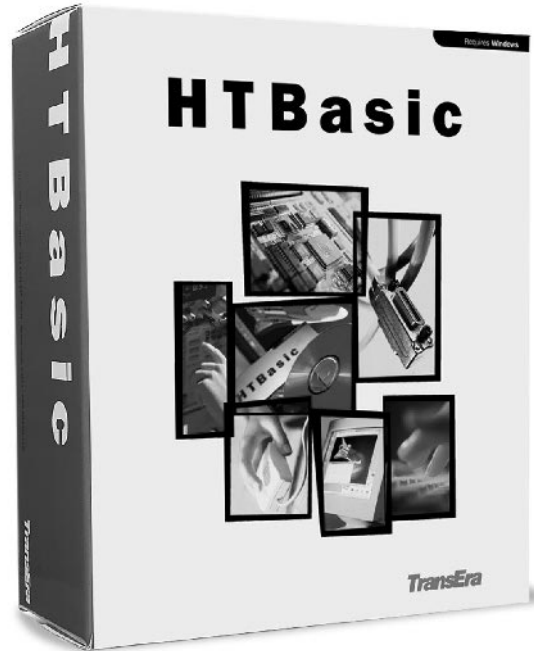

E2060D HTBasic for Windows, brings the power and ease of use of the popular HP BASIC (also known as Rocky Mountain Basic) to the PC and the Microsoft Windows operating system.

In addition to the traditional HTBasic Legacy Editor, HTBasic for Windows includes a new windows-style editor with cut, copy and paste, undo and redo, bookmarks, user-definable fonts, keyword colors, colored syntax error identification, and the ability to turn line numbering on or off for programming ease.

The DLL Toolkit allows HTBasic to call Dynamic Link Libraries (DLLs) written in other languages (most notably C/C++).

HTBasic now includes LONG integers, STATIC variables, COMPLEX numbers, matrix math, and structured programming. The TRANSFER function for GPIB, serial and file is fully supported.

Integrated debugger speeds program development. Set conditional and global breakpoints, step into, step over, or step out of subprograms. Includes six exclusive debugging windows for Watch Variables, Line Breakpoints, Global Breakpoints, Trace, Call Stack, and a Code Window.

Improved HELP online documentation and fully functional search capabilities including find/replace and next/previous error searches.

Uses familiar HP BASIC syntax to control GPIB, GPIO, and data acquisition cards.

HTBasic for Windows also includes both HTBasic Legacy products: HTBasic for DOS and HTBasic for Windows (3.1 support). Diskette creation utilities are included to create diskettes for running these older Legacy Versions on machines without a CD-ROM drive.

Includes BASIC Plus with Dialog Statements for information like errors, file names, lists, questions, and warnings; Data Input Widgets like keypad, pushbutton, radiobutton, scrollbar, slider, and togglebutton; Data Output Widgets like bars, bitmaps, clocks, meters, and stripcharts; and Menu Creation Widgets like menu button, cascade menus, and pulldown menus.

**Specifications**

HTBasic for Windows Requirements	
CPU	486/Pentium
Operating System	Microsoft Windows 95/98/NT 4.0/2000
Hardware	30 MB of free disk space 32 MB system RAM CD-ROM drive
HTBasic Legacy Version Requirements	
CPU	386/486/Pentium
Operating System	DOS 3.x or later, Microsoft Windows 3.1 (requires WIN32s, which is included), Windows 95/98/NT 4.0/2000
Memory	4MB of free disk space, 8MB of system RAM
I/O Cards Supported	
GPIB (IEEE-488)	<a href="http://www.htbasic.com/support/gpib.html">www.htbasic.com/support/gpib.html</a>
Serial	Windows compatible serial interfaces
GPIO	2075A GPIO TransEra Model 600
SRM	TAMS E2085G

**Ordering Instructions**

[www.agilent.com/find/htbasic](http://www.agilent.com/find/htbasic)

Description	Product No.
HTBasic for Windows	E2060D

Support and volume products are also available; see web site or contact Agilent.

Overview

- Optimized for RF and microwave automatic test systems
- Modular for easier system integration
- Wide variety of products and configurations available



Agilent Technologies developed and supplies an integrated rack of RF test equipment for communication satellite payload test. MMS signal generators, spectrum analyzers and power meters were selected for a compact, EMC-rugged, highly-accurate, 1 GHz to 20 GHz broadband system. The 70611A Attenuator/Switch Driver (an MMS system module) is included providing a convenient inter-face to a custom switch matrix.

### Modular Measurement System

The Modular Measurement System (MMS) is an open, industry standard controlled by a consortium. The high-performance, modular platform is especially suited for RF, microwave, and lightwave test applications. It offers the lowest life-cycle cost when you integrate, support or upgrade your system. The MMS offers system designers a number of advantages:

- A wide variety of over 50 modules offer low frequency, RF, microwave and light-wave measurement capability.
- Easy system integration is aided by standard- and custom-switching modules, plus an open architecture with design tools that allow you to design and build your own specialized modules.

- Easy-to-use displays allow you to operate a system from local or remote locations, and mainframes and displays can be separated by up to 1 kilometer.
- Electromagnetic compatibility (EMC) design is optimized for microwave environments. Rugged mainframes, shielded enclosures, grounding and a 40 kHz switched power supply reduce emissions and module-to-module interference.
- Automatic system control can be based on DOS, BASIC or UNIX<sup>®</sup> operating systems.
- Compatibility with other open standards allows you to make use of new and existing hardware, software and engineering expertise. MMS and VXI combine easily to solve complex measurement requirements. Both platforms continue to take advantage of their own internal high-speed bus, but can be tied to a common 10 MHz clock reference. Both use common trigger signal levels.

### Maximize Your Investment

Several factors reduce MMS life-cycle costs:

- MMS integrates quickly, using off-the-shelf mainframes, components and software packages.
- MMS allows system configuration to provide just the right amount of measurement capability.

- Downsizing enhances ATE systems by reducing rack space.
- A central, shared display allows operator focus and monitors up to four instruments at once in real time. This further reduces rack space. The system will even work without a display, saving more space and reducing cost.
- Built-in diagnostics and modularity team up to maximize system uptime, allowing the best use of your investment.

### 70000 Modular Measurement System

Agilent offers a variety of products and services to help you customize your entire system. Multiple support alternatives allow you to customize the logistics of each system to fit installation needs. With MMS, you are assured of the highest performance and best customer support—today, and in the years to come. Your Agilent sales representative can help you configure the best solution for your specific application.

The following pages highlight selected components and systems in the 70000 family. A complete listing of all MMS products and most MMS products from other suppliers with full descriptions, specifications and services is also available on our web site: [www.agilent.com](http://www.agilent.com)



71400C with 70810B



71451B

### 70000 MMS Product Information

#### Mainframes and Displays

Product	Description
<b>70001A System Mainframe</b>	8-slot mainframe for MMS plug-in modules
<b>70205A Display</b>	Compact, 3-slot module format
<b>70004A Color Display and Mainframe</b>	Integrated mainframe and display 4 available module slots

#### Instruments

Choose from instruments that are single modules or multiple modules configured into a system.

#### Sources

Product	Description
<b>71708A Microwave Source, 2.4 to 25.8 GHz</b>	Excellent LO substitute for radar, phase noise measurement systems; test source for receiver test systems
<b>70428A Microwave Source Module, 2.4 to 25.8 GHz</b>	600 MHz frequency resolution (0.1 Hz option) Up to +16 dBm output power 8-slot system includes mainframe display; 4-slot module

#### Signal Analyzers

Product	Description
<b>70100A Power Meter, 100 kHz to 50 GHz</b>	Single-channel module 1-slot width
<b>70110A Digital Multimeter</b>	3 1/2 to 6 1/2 digits of resolution 2-slot width
<b>P 70120A Universal Counter</b>	100 MHz, 200 MHz, 2.4 GHz inputs 1-slot width
<b>70703A Digitizing Oscilloscope</b>	4-input, 2-channel operation 500 MHz 2-slot width
<b>71500A Microwave Transition Analyzer, DC to 40 GHz</b>	2-channels, sampler-based, internal trigger Time-domain measurements with FFTs
<b>71707A Microwave Downconverter, 2 GHz to 26.5 GHz</b>	Translates microwave signals to RF frequencies for phase noise measurements
<b>70427A Microwave Downconverter Module, 2 GHz to 26.5 GHz</b>	

#### Spectrum Analyzers and Receivers

Product	Description
<b>All 70000 series spectrum analyzers offer the following:</b>	10 Hz minimum bandwidth 90 dB calibrated display range 0.1 ppm frequency stability
<b>71100C RF Spectrum Analyzer, 100 Hz to 2.9 GHz</b>	Synthesized, high performance RF spectrum analysis -134 dBm sensitivity, -156 dBm with preamplifiers
<b>71209A Microwave Spectrum Analyzer, 100 Hz to 26.5 GHz</b>	Continuous sweeps from 100 Hz to 26.5 or 40 GHz -138 to -128 dBm sensitivity across the frequency range (71209A/P); -107 dBm at 40 GHz (Option Z40)
<b>71209A Option Z40 Spectrum Analyzer, 100 Hz to 40 GHz</b>	Built-in external mixer interface for mm applications 2-mainframe system with 5 slots
<b>71210C Microwave Spectrum Analyzer, 100 Hz to 22 GHz</b>	Fundamentally mixed, highest microwave performance -139 dBm sensitivity at 1 GHz; -133 dBm at 22 GHz; -155 dBm at 22 GHz with
<b>71910A</b>	Includes 71209A/P

#### Lightwave and Communication

Product	Description
<b>71400C Lightwave Signal Analyzer, 100 Hz to 22 GHz</b>	Calibrated measurement of intensity modulation from 100 kHz to 22 GHz 1200 to 1600 nm operation (750 to 870 nm option 850)
<b>71401C Lightwave Signal Analyzer, 100 Hz to 2.9 GHz</b>	RIN measurements to -165 dB/Hz Interferometer for laser linewidth and chirp measurements Systems based on 71210C spectrum analyzer
<b>70810B Lightwave Signal Analyzer Module</b>	2-mainframe systems with 4 slots available
<b>71450B Optical Spectrum Analyzer</b>	Spectral measurements from 600 to 1700 nm Double-pass monochromator Real-time sweep rates
<b>71451B Optical Spectrum Analyzer</b>	-90 dBm sensitivity, 60 dB dynamic range Wavelength and amplitude calibration across full measurement range
<b>71452B Optical Spectrum Analyzer</b>	Optional current source and white light source 5 modes of operation (71452B) 1 mainframe system with color display
<b>71501C Jitter Analysis System</b>	Expanded measurement range: 50 Mb/s to > 12 Gb/s Jitter transfer, tolerance, output/generation Test systems, networks, modules or components, MUX/DEMUX Eye-diagram and analysis capability

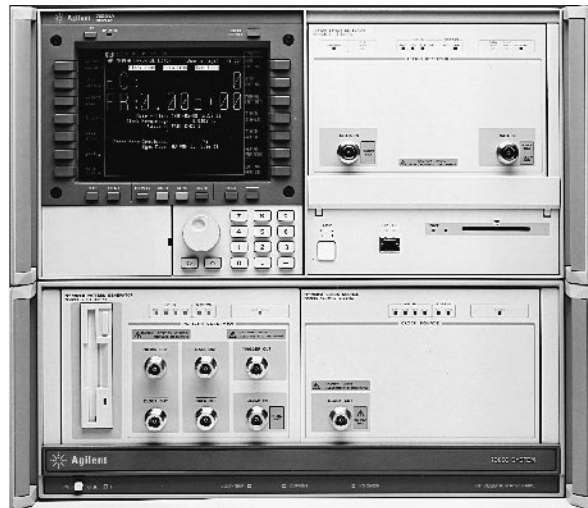

71604B



MMS System with 70612A

Product	Description
<b>71603B Gigabit Error Performance Analyzer</b>	100 Mb/s to 1 Gb/s pattern generation and error performance analysis Low-phase-noise clock source User-programmable patterns up to 4 Mb with screen-based editor
<b>71604B Pattern Generator</b>	Ability to trigger anywhere in pattern Variable clock/data delay Automatic setting of threshold and decision point True complementary outputs 2-mainframe systems with color display
<b>71612A Series Gigabit Error Performance Analyzers and Pattern Generators</b>	100 Mb/s to 12 Gb/s pattern generation and error performance analysis 8 Mb programmable pattern Fast transition times, low jitter Burst-mode capability for fiberloop testing Four sub-rate outputs Location of specific errored bits 2-mainframe systems with color display

POA = Price on application.

### System Building Blocks

Configure an instrument or system for unique applications using off-the-shelf modules.

Product	Description
<b>70310A Precision Frequency Reference</b>	10 MHz to 100 MHz precision reference 1-slot width
<b>70620B Preamplifier, 1 GHz to 26.5 GHz</b>	Boost sensitivity of analyzers by 15 to 25 dB -156 dBm sensitivity at 2.9 GHz -150 dBm sensitivity at 22 GHz Optional 100 kHz low-end frequency Built-in switches for preamplifier bypass
<b>70621A Preamplifier, 100 kHz to 2.9 GHz</b>	Optional 100 kHz low-end frequency Built-in switches for preamplifier bypass
<b>70900B Local Oscillator</b>	Master control module for spectrum analyzers 2-slot width
<b>70860A Upgrade Kit</b>	High-speed controller board upgrades 70900A with features of 70900B
<b>70861A Upgrade Kit</b>	RAM/ROM board upgrades firmware to 70900B capabilities

Product	Description
<b>70902A IF Section, 10 Hz to 300 kHz</b>	Adds signal processing elements for spectrum analyzers 1-slot width
<b>70903A IF Section, 100 kHz to 3 MHz</b>	
<b>70911A IF Section, 10 MHz to 100 MHz bandwidths</b>	Used in 71910A wide bandwidth receiver 2-slot width
<b>70904A RF Section, 100 Hz to 2.9 GHz</b>	Broadband input conversion for spectrum analyzers 1-slot width
<b>70908A RF Section, 100 Hz to 22 GHz</b>	Fundamentally mixed broadband input conversion for analyzers 2-slot width
<b>70909A RF Section, 100 Hz to 26.5 GHz</b>	Diode-pair mixing, built-in preamplifier for improved sensitivity Switchable bypass filter around YIG tuned filter (70910A) 2-slot width
<b>70910A RF Section, 100 Hz to 26.5 GHz</b>	
<b>70907B External Mixer Interface Module</b>	Interface for external mixers 1-slot width

### System Integration

Quickly integrate your test system using these resources and tools.

Product	Description
<b>70611A Attenuator/Switch Driver</b>	Controls up to 31 electro-mechanical mechanical switches or attenuator 1-slot module

### Service and Support

The MMS offers many support alternatives. The system design allows modules to be exchanged in the field without loss of system calibration. For multiple-module systems, you can add new modules or replace existing ones and run the one-button internal calibration routine. Spares can be stocked based on the MTBF of individual modules—often greater than 15,000 hours. Many MMS instruments have built-in or downloadable diagnostic routines for locating faults. And Agilent provides for return-to-factory repair and calibration of systems, and offers MIL-STD-45622A certification that is valid for up to three years.



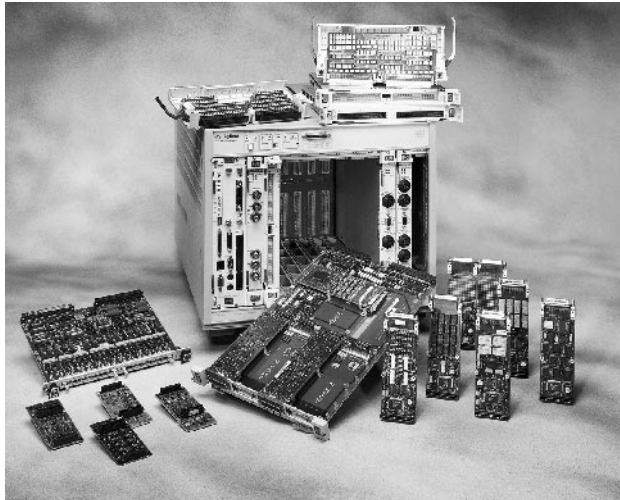

The E8408A is Agilent's smallest footprint, lowest-priced C-size mainframe.

## VXIbus Introduction

In 1987, a consortium led by several major test and measurement manufacturers, including Hewlett-Packard, introduced VXIbus, a new standard modular instrument architecture. VXIbus was developed to meet the needs for portable applications, particularly for the military, and to provide an industry-standard instrument architecture with an interface speed significantly higher than that of the GPIB interface. The design of this new architecture allowed the integration of VXIbus products into traditional GPIB test systems and for standalone applications. Today, the VXIbus Consortium continues to refine the VXIbus standard and Hewlett-Packard remains an active member.

Since the inception of VXIbus, other standards have been developed, which reduce users' dependence on any one vendor. This lowers the risks and provides maximum investment protection in hardware and software purchases and system development. Agilent's VXIbus products support the industry-accepted *VXIplug&play* instrument drivers<sup>1</sup>. One set of these standard drivers for the MS Windows environment, for example, is supported by any of several popular software packages: Agilent VEE, Microsoft C/C++, Visual Basic, Borland C/C++, and NI Lab Windows. Other supported environments are Windows 95/NT, HP-UX, and SUN-OS.

Compact size, high throughput, and flexibility best characterize VXIbus. Today you can use VXIbus products to build a variety of test systems from portable testers for field use and remote data acquisition applications to high-performance data acquisition and functional test systems. While some systems are entirely VXIbus products, many users are integrating VXIbus along with traditional GPIB instruments. Today VXIbus manufacturers and numerous third-party integrators now are offering dedicated measurement solutions using the VXIbus platform. Agilent offers several integrated products based on VXIbus.

The pages which follow give a brief overview of the VXIbus Standard and a list of VXIbus products offered. For additional configuration and product ordering information, separate documents are available. For a free Agilent Test System and VXI Products Catalog, in the USA call 1-800-452-4844 or visit our web site: [www.agilent.com/find/vxi](http://www.agilent.com/find/vxi)

<sup>1</sup> HP (now Agilent) joined the *VXIplug&play* Alliance in 1994 and has contributed to the definition of its industry-standard instrument drivers now provided by numerous VXI manufacturers.

## The VXIbus Architecture

VXIbus is defined around the highly popular VMEbus architecture known for its excellent computer backplane. High-speed data rates of 40 MB/s along with the necessary communication protocols make it ideal for building instrument systems for high throughputs. VXIbus incorporates the ease-of-use features of intelligent GPIB instruments (for example, ASCII-level programming) into its message-based devices. It also takes advantage of the high-throughput capability of VMEbus devices which are programmed and communicate directly in binary.

Although VMEbus is an excellent computer backplane, it is not adequate for instrumentation without further standardization. The VXIbus Consortium fully defined the operating environment for instrumentation modules. All VXIbus mainframes must state how much power and cooling they provide. And all VXIbus modules must state how much power and cooling they require. Also, there are strict limits on how much conducted and radiated interference is allowed between modules. These parameters allow you to easily configure a workable system.

VXIbus systems provide backplane management and resource management functions. Slot 0, a unique physical location in every VXIbus mainframe, handles the backplane by providing clock signals, data movement arbitration, and more. The Resource Manager program configures the modules for proper operation whenever the system is powered on.

## Mechanical and Electrical

The VXIbus specification defines a scalable family of four module sizes. The two smaller sizes, A and B, are the defined VMEbus module sizes, and are true VMEbus modules in every sense of the word. The two larger sizes, C and D, are additional sizes to allow higher performance instrumentation. Increased module spacing in the C- and D-size systems makes it possible to fully shield sensitive circuits for high-performance measurements. VXIbus is a scalable architecture, and allows smaller module sizes to fit into larger mainframes.

VXIbus provides other resources for instrumentation. These include additional power supply voltages for powering analog and ECL circuits, and implementation buses for measurement synchronization and triggering. Included are an analog summing bus and a set of local bus lines for private module-to-module communication. Additionally, stringent EMC and noise requirements are specified to maintain an interference-free environment for sensitive instrumentation.

VXIbus specifies three 96-pin DIN connectors: P1, P2, and P3 (page 94). The P1 connector, the only mandatory connector in VMEbus or VXIbus, carries the data transfer bus (up to 24 bits addressing and 16 bits data), the interrupt buses, and some power. The optional P2 connector, available to all card sizes except A-size, expands the data transfer bus and provides the additional resources as shown with particular pin assignments. The local bus indicated is a powerful feature provided by VXIbus. This flexible daisy-chain bus structure allows for adjacent modules to conduct private, high-speed communication.

## VXIbus Connectors

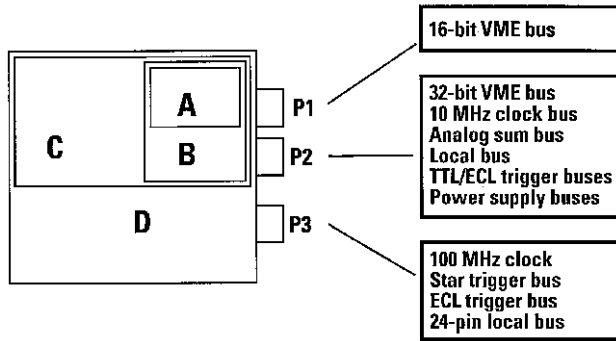

## Power and Cooling

3

VXIbus specifies a set of guidelines to ensure adequate cooling. Every vendor's mainframe specifications sheet provides cooling specifications for worse-case module configuration. Available airflow as a function of the maximum allowable pressure differential across any module is specified. This is matched against the specified airflow and pressure parameters specified for each module.

Values of peak dc current and peak-to-peak dynamic current are specified for each module. The system integrator can match the total module current loading to the capacity of the mainframe. The dynamic current specification assures ripple-free noise on the mainframe's power supply lines.

## Communications

A more standardized set of communication protocols is defined for VXIbus systems to handle autoconfiguration, resource management, and device communication. The Resource Manager, a message-based commander, takes care of the configuration tasks. It sets up the shared address space, manages the system self-test, creates the commander-servant hierarchies, and then releases the system for operation fully configured.

A message-based device, which communicates directly in SCPI (ASCII), is commonly the most intelligent VXIbus device. Typically it uses a microprocessor and is more costly than a register-based device, but is easier to integrate into a VXIbus system. Most message-based devices provide moderate throughput performance in a VXIbus system.

The most basic level of communication is that handled through register-level (binary-level) reads and writes to the registers of the register-based device (in some instances, direct-register access is provided on a message-based device to improve throughput performance). The register-based device is often controlled by an intelligent message-based device, its commander (command module or embedded controller). The commander interprets SCPI (ASCII) instrument commands converting them into binary for communication to the register-based device. To avoid the speed-reducing effects of the SCPI interpretation, compiled SCPI is used to compile the SCPI instrument commands before runtime. Runtime speeds, then, are commensurate with binary-level speeds as though the user had programmed directly in binary.

An IEEE-488-to-VXIbus interface is also defined in the VXIbus specification allowing for easy integration of VXIbus and GPIB products into one system. Agilent's Command Module (E1406A), for example, provides the GPIB connection for interfacing to an external GPIB controller. For high-throughput systems, an industry-standard interface, IEEE-1394 (FireWire), is provided in the E8491B PC link to VXI.

## Summary

- The benefits of industry-standard VXIbus systems are these:
- Downsizing to save costly rack space
  - High-performance, high-throughput measurement capability
  - Reduced time and cost for system development
  - Reduced dependency on proprietary architectures

The following pages provide a listing of Agilent's VXI products. For product details and specifications, please refer to Agilent's Test System and VXI Products Catalog. To obtain a copy, please visit our web site: [www.agilent.com/find/vxi](http://www.agilent.com/find/vxi), or in the U.S. call 800-452-4844.



The E8491B PC to VXI Link provides IEEE-1394 (FireWire) interface capability to your VXI test system.



The E6432A VXI Microwave Synthesizer delivers CW signals with low phase noise and excellent spectral purity.

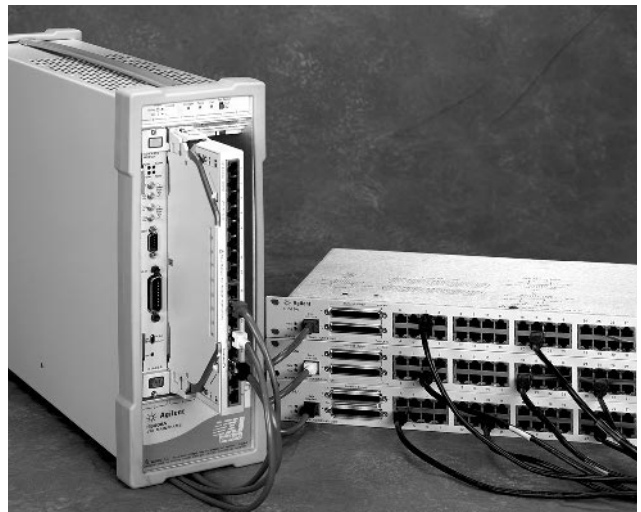

The E1529A Remote Strain Conditioning Unit simplifies structural testing of designs that require many channels of strain measurement.

### 75000 VXI Products Information

Model No.	Description
<b>Mainframes</b>	
<b>E8408A</b>	4-Slot, C-Size VXI Mainframe with options to add GPIB Command Module or IEEE-1394 Slot-0 Interface
<b>E8401A</b>	Low-cost, Medium Power C-Size VXI Mainframe, 13-Slot
<b>E8403A</b>	High Power, C-Size VXI Mainframe, 13-Slot, standard monitoring.
<b>E8404A</b>	High Power, Enhanced Monitoring C-Size VXI Mainframe, 13-Slot
<b>E1401B</b>	High-Power Mainframe, C-size, 13-slot; racking options available
<b>E1421B</b>	Mainframe, C-size, 6-slot; racking options
<b>E1300B/01B</b>	Mainframes, B-size, 7-slot; built-in 68000 processor and IEEE-488 and RS-232 interfaces; Options: dc power, memory, mass storage, IBASIC
<b>Controllers</b>	
<b>E1406A</b>	Command Module, C-1, message-based commander, SCPI translator for register-based modules; optional expanded memory available
<b>E6234A</b> <b>E6237A</b>	VXI Pentium® PC Controller WIN 95/NT VXI Pentium® PC Controller LynxOS
<b>E9850A</b>	VXI Embedded PC Controller, 450 MHz WIN NT <span style="float:right">NEW</span>
<b>E4208D</b>	SCSI Disk, C-1, 4 GB hard drive, 1.44 MB, 3.5-inch floppy
<b>E3249B</b>	SCSI System Disk, C-2, 4.3 GB hard drive, 4 GB DAT tape
<b>N2216AA</b>	Data Disk and SCSI-2 Interface, VXI <span style="float:right">NEW</span>
<b>Interface</b>	
<b>E8491B</b>	IEEE-1394 PC Link to VXI C-Size, Opt 001
<b>E1482B</b>	VXIbus-to-MXIbus Extender, C-size, 1-slot; Connect two or more VXI mainframes together, or interface to external MXIbus controllers
<b>E1489C</b>	EISA/ISA-to-MXI interface; For direct VXI backplane interface to HP 9000 series 700 controllers
<b>E2749A</b>	Fibre Channel Data I/O Module
<b>Application Software</b>	
<b>E2120G</b>	VEE Pro 6.0, Graphical Programming Language, Windows version <span style="float:right">NEW</span>
<b>E2060C</b>	HP BASIC for Windows: based on the popular HP Rocky Mountain Basic language

Model No.	Description	Price
<b>Measurement</b>		
<b>E1312A,</b> <b>E1412A</b>	6.5 Digit Multimeter, B-2/C-1, RB/MB, Vac/dc, lac/dc, 2/4-w ohms, frequency, period	
<b>E1411B,</b> <b>E1326B</b>	5 Digit Multimeter, C-1/B1, RB, Vdc/ac, 2/4-w Ω, temperature	
<b>E1428A</b>	1GSa/s Digitizing Oscilloscope, C-1, MB, 2-Ch., 8 b, 250 MHz bw	
<b>E1430A</b>	10 MSa/s A/D with DSP, C-1, RB 1-Ch., 23 b, 4 MHz bw, 24 digital filters, FIFO	
<b>E1432A</b>	16-Ch. 51.2 kHz Digitizer plus DSP C-1, RB, 16-bit, 4-32 MB FIFO, digital anti-alias filters	
<b>E1433B</b>	8-Ch. 196 kSa/s Digitizer plus DSP, C-1, RB, 16 b, digital anti-alias filters, 4-32 MB FIFO, 88 kHz bw	
<b>E1437A</b>	20 MSa/s Digitizer with DSP, C-1, MB/RB, 1-Ch., 23 b, 8 MHz bw, 24 digital filters, FIFO	
<b>E1438A,</b>	100 MSa/s Digitizer with DSP, C-1, RB, 1-Ch., 12 bit, 40 MHz BW, AAF, 17 dig. filters, FIFO <span style="float:right">NEW</span>	
<b>E1439A</b>	95 MSa/s Digitizer with DSP, 70 MHz IF input, C-1, RB, 1-Ch., 12 bit, 36 MHz BW, AAF, 17 dig. filters, FIFO <span style="float:right">NEW</span>	
<b>SCMVX008</b>	Digital Signal Processor, Dual 60 MHz, Tms 320, C40 DSP with 6 expansion slots	
<b>E3242A</b>	Breakout Box accessory interfaces charge and IEPE accelerometers to E1432A/33AVXI Digitizers	
<b>E3243A</b>	Breakout Box accessory interfaces microphones and IEPE accelerometers to E1432A/33A VXI Digitizers	
<b>E3245A</b>	12-channel mini-phone plugbreakout box to 26-pin high density connector.	
<b>E1413C</b>	64-Ch. Scanning A/D, C-1, RB, 16 b, 100 kSa/s	
<b>E1415A</b>	Algorithmic Closed-Loop Controller, C-1, RB, 16 b A/D with signal conditioning	
<b>E1419A</b>	Multi-Function Measurement and Control	
<b>E1420B</b>	High-Performance Universal Counter, C-1, MB, 2-Ch., 200 MHz/2 GHz	
<b>E1332A</b>	4-Ch. Counter/Totalizer, B-1, RB, 4 MHz	
<b>E1333A</b>	3-Ch. Universal Counter, B-1, RB, 1 GHz	
<b>E1740A</b>	150 MHz Time Interval Analyzer, C-2, MB, 80 M rdgs/s, 100 ps rms	
<b>E1416A</b>	Power Meter, C-1, MB, 1-Ch., 110 GHz	
<b>E1485C</b>	Digital Signal Processor, C-1, 40 MHz Motorola 96002 DSP with 4 expansion slots	
<b>SCMVX008</b>	Digital Signal Processor, C-1, two 60 MHz TMS320C40 DSPs with 6 expansion slots	
<b>E1529A</b>	Remote strain conditioning unit	
<b>E1563A,</b> <b>E1564A</b>	2-, 4-Ch., 800 kSa/s Digitizers	
<b>M-Modules</b>		
<b>E2251A</b>	C-Size M-Module Carrier	
<b>E2261A</b>	Quad RS-232 Interface M-Module	
<b>E2270A</b>	16-Ch. Form A Switch M-Module	
<b>E2271A</b>	4x4 Matrix Switch M-Module	
<b>E2272A</b>	Dual 8-to-1 Relay Multiplexer M-Module	
<b>E2273A</b>	8-Ch. Form C Switch M-Module	
<b>E2290A</b>	16-bit Digital I/O M-Module	

### 75000 VXI Products Information

Model No.	Description
<b>Sources and Amplifiers</b>	
<b>E1445A</b>	Arbitrary Function Generator, C-1, MB, 13 b, 40 Msa/s, 10.2 V p-p (50 Ω), sweep, waveforms: arb, sine, square, ramp; Optional waveform software available
<b>E1328A</b>	4-Ch. D/A Converter, B-1, RB, 16 b, 1.3 kSa/s, 10.92 V dc
<b>E1434A</b>	4-Ch. 65 kSa/s Arbitrary Source, C-1, RB, 16-20 bit, 10 V, sine, 25.6 kHz, bw, random, swept sine, 4-32 MB RAM FIFO
<b>E1418A</b>	8/16-Ch D/A Converter, C-1, RB programmable isolation, ± 16 V, ± 20 mA, 16 bit 1 kHz update rate
<b>E1441A</b>	Arbitrary Waveform Generator
<b>E1750A/52A</b>	Broadband Freq./Pulse Amplifiers, C-1, RB, 10 MHz/10 M PPS, 6-Ch., sine/pulse, 1 Vrms (50 Ω)
<b>E6432A</b>	Microwave synthesizer (10 MHz to 20 GHz with 1 Hz resolution)
<b>E8311A</b>	C-1, 165 MHz/Pulse/Pattern Generator, 2 output channels, 10Vpp (50 Ω into 50 Ω), 20Vpp (1 K Ω into 50 Ω), 16kbit patterns, 5ps timing resolution, 0.01% frequency accuracy, variable transition times (2 ns to 200 ms)
<b>E8312A</b>	C-1, 330 MHz/660 Mbit/s, Pulse/Pattern Generator, 2 output channels, 3.8Vpp, 16kbit patterns, 5ps timing resolution, 0.01% frequency accuracy, 0.8ns or 1.6ns fixed transition times
<b>Digital</b>	
<b>E1330B</b>	Quad 8-bit Digital I/O, B-1, RB, 32-Ch., I or O, TTL, 325 kb/s
<b>E1339A</b>	72-Ch. Open-Collector Dig Out/Relay Driver
<b>E1452A</b>	Pattern I/O Module, C-1, RB 32-Ch., Input or Output, TTL/CMOS, 20 M patterns/s
<b>E1458A</b>	96-Ch. Digital I/O, C-2, RB, 96-Ch., I or O, TTL
<b>E1459A</b>	64-Ch. Isolated Dig Input/Interrupt
<b>Switches—Relay Multiplexer</b>	
<b>E1343A</b>	16-Ch., 3-w, B-1, RB, Reed, < 10 μV, 250 V, 10 MHz, 50 mA
<b>E1344A</b>	16-Ch., T/C, 3-w, B-1, RB, Reed, < 10 μV, 250 V, 10 MHz, 50 mA
<b>E1345A</b>	16-Ch., 3-w, B-1, RB, Reed, < 4 μV, 120 V, 10 MHz, 50 mA
<b>E1346A</b>	48-Ch., 1-w, B-1, RB, Reed, < 50 μV, 120 V, 10 MHz, 50 mA
<b>E1347A</b>	16-Ch., T/C, 3-w, B-1, RB, Reed, < 4 μV, 120 V, 10 MHz, 50 mA
<b>E1351A</b>	16-Ch., 2-w, B-1, RB, FET, < 25 μV, 16 V, 100 kHz, 1 mA
<b>E1352A</b>	32-Ch., 2-w, B-1, RB, FET, < 25 μV, 16 V, 100 kHz, 1 mA
<b>E1353A</b>	16-Ch., 1-w, B-1, RB, FET, < 25 μV, 16 V, 100 kHz, 1 mA
<b>E1460A</b>	64/32/128-Ch. 2/3/1-w, C-1, RB, Armature/L, < 7 μV, 60 V, 1 MHz, 1 A
<b>E1476A</b>	64-Ch. 3-w, 32-Ch. 4-w, C-1, RB, Reed, voltage, current, temperature (T/C)
<b>E8460A</b>	256-Ch. Reed Relay Multiplexer
<b>E8462A</b>	256-Ch. Armature Relay Multiplexer

Model No.	Description
<b>Switches—RF Relay Multiplexer</b>	
<b>E1366A</b>	Dual 1x4, 50 Ω, B-1, RB, Armature, < 6 μV, 42 V, 1.3 GHz, 1 A
<b>E1367A</b>	Dual 1x4, 75 Ω, B-1, RB, Armature, < 6 μV, 42 V, 1.3 GHz, 1 A
<b>E1470A</b>	60-Ch. Cascade RF Multiplexer, 60:1 to 20 3:1, 50 Ω, C-1, RB, Armature, < 6 μV, 30 V, 500 MHz (3:1), 450 mA (AC)
<b>E1472A/73A</b>	Six 1x4, 50 Ω, C-1, RB, Armature, < 6 μV, 42 V, 1.3 GHz, 1 A
<b>E1474A/75A</b>	Six 1x4, 75 Ω, C-1, RB, Armature, < 6 μV, 42 V, 1.3 GHz, 1 A
<b>Switches—Microwave</b>	
<b>E1368A</b>	50 Ω, 3-Ch. Form C (SPDT), B-1, RB, Armature, 18 GHz
<b>E1369A</b>	Switch Driver, B-1, RB, drives switches up to 26.5 GHz
<b>E1370A</b>	Switch/Attenuator Driver, B-2, RB, drives switches up to 26.5 GHz
<b>Switches—Matrix</b>	
<b>E1361A</b>	4x4, 2-w, B-1, RB, Armature, < 14 μV, 250 V, 10 MHz, 1 A
<b>E1465A</b>	16x16, 2-w, C-1, RB, Armature/L, < 5 μV, 200 V, 10 MHz, 1 A
<b>E1466A</b>	4x64, 2-w, C-1, RB, Armature/L, < 5 μV, 200 V, 10 MHz, 1 A
<b>E1467A</b>	8x32, 2-w, C-1, RB, Armature/L, < 5 μV, 200 V, 10 MHz, 1 A
<b>E1468A</b>	8x8, 2-w, C-1, RB, Armature/L, < 7 μV, 220 V, 10 MHz, 1 A
<b>E1469A</b>	4x16, 2-w, C-1, RB, Armature/L, < 7 μV, 220 V, 10 MHz, 1 A
<b>Switches—General Purpose</b>	
<b>E1364A</b>	16-Ch., Form C (SPDT), B-1, RB, Armature, < 7 mV, 250 V, 10 MHz, 1 A
<b>E1463A</b>	32-Ch. Form C (SPDT), C-1, RB, Armature, < 7 mV, 125 V, 10 MHz, 5 A
<b>E1442A</b>	64-Ch., Form C/A (SPDT), C-1, RB, Armature, < 170 mV, 150 V, 10 MHz, 1 A
<b>Optical Switches</b>	
<b>E4502A/03A/04A</b>	2-1x4 / 1-1x16 / 2-1x8 Optical Switches, C-1, RB
<b>Special Purpose Modules</b>	
<b>WJC9119S/M</b>	High Frequency Tuner (down converter) C-2, RB, 32 MHz

C-1 means C-size, 1 slot; B-2 means B-size, 2 slot; RB means Register-based; MB means Message-based, DIO means digital input/output



Agilent's switch family provides you with long-lasting quality, reliability, and performance for your small, medium, or large test system. Agilent offers modular test systems with plug-in switch modules and dedicated instrumentation and fixturing.

### VXIbus Modular Test Systems

The 75000 B- and C-size VXI test systems provide a modular architecture with numerous switches and instruments. These systems contain the most versatile switching solutions in the industry-standard VXI format. The C-size VXI system is the most popular architecture for high-performance, high-speed applications that require both switching and instrumentation. The B-size VXI system is ideal for applications requiring switching and some instrumentation.

- General purpose
- Matrix
- Multiplexers/scanners
- Microwave/RF
- Full line of instruments (refer to pages 95–96 for more information on VXI test systems)

### 3499 for Manufacturing Test and Desktop Switching

The Agilent 3499A/B switching/control systems are ideal for use in manufacturing test application where a high-speed, high density switching solution is needed. The 3499 family includes two mainframes, one with two slots and the other with five slots, it also includes 26 plug-in modules, making it cost effective for any size application. Existing 3488A users can easily upgrade to the 3499A because both the

hardware and software are compatible. The following modules are available for the 3499A/B:

- 40-channel multiplexer
- 4 x 8 Matrix
- 12 General Purpose + 3 high current General Purpose + 16-bit Digital I/O
- 4 x 4 Matrix + 16-bit Digital I/O
- 40-channel high speed multiplexer
- 8-channel 8 A General Purpose
- 40-channel General Purpose
- 32-bit Digital I/O
- 10-channel 1000 V multiplexer
- 32-bit Isolated Digital I/O + 2 DACs
- 3.5 GHz Dual 1 x 4 multiplexer
- Quad 1 x 2 optical multiplexer, SC/APC
- Dual 1 x 4 optical multiplexer, SC/APC

Refer to page 98 for more information on the 3499A/B.

### 34970A for Low-Cost Switching

The 34970A Data Acquisition/Switch Unit is ideal for cost-sensitive applications with small- to mid-sized channel count requirements. The three-slot mainframe offers eight switch and control modules which cover a broad spectrum of capabilities.

- Low-frequency multiplexing to 300 V
- 2 GHz RF switching (both 50 and 75 ohms)
- Matrix switching/General Purpose/Form-C switching
- Digital IO/Analog output/Event counting

Refer to page 154 for more information on the 34970A.

The Switch Module Selection Table on this page provides comparative information for each of the VXIbus switches.

Model #	Description	Size, Slots	Switching Type (L-latching)	Thermal Offset (per ch.)	Max. Volts (DC)	Bandwidth (–3 dB)	Current Rating	Closed Channel Resistance ( $\Omega$ , initial)
<b>Relay Multiplexers</b>								
E1343A	16-Channel, 3-wire	B, 1	Reed relay	<10 $\mu$ V	250 V	10 MHz	50 mA	100 $\pm$ 10%
E1344A	16-Channel T/C, 3-wire	B, 1	Reed relay	<10 $\mu$ V	250 V	10 MHz	50 mA	100 $\pm$ 10%
E1345A	16-Channel, 3-wire	B, 1	Reed relay	<4 $\mu$ V	120 V	10 MHz	50 mA	100 $\pm$ 10%
E1346A	48-Channel, 1-wire	B, 1	Reed relay	<50 $\mu$ V	120 V	10 MHz	50 mA	100 $\pm$ 10%
E1347A	16-Channel T/C, 3-wire	B, 1	Reed relay	<4 $\mu$ V	120 V	10 MHz	50 mA	100 $\pm$ 10%
E1351A	16-Channel, 3-wire	B, 1	FET	<25 $\mu$ V	16 V	100 kHz	1 mA	<3.1 k
E1352A	32-Channel, 1-wire	B, 1	FET	<25 $\mu$ V	16 V	500 kHz	1 mA	<3.1 k
E1353A	16-Channel, T/C 3-wire	B, 1	FET	<25 $\mu$ V	16 V	500 kHz	1 mA	<3.1 k
E1460A	64 Channel Relay Unit	C, 1	Armature, L	<7 $\mu$ V	220 V	3/10 MHz	0.3, 1 A	<1.5
E1476A	64-Channel, 3-wire	C, 1	Reed relay	<2 $\mu$ V	120 V	100 kHz	35 mA	100 $\pm$ 5%
E8460A	256-Ch. Relay Multiplexer	C, 1	Reed relay	50 $\mu$ V	200 V	100 kHz	300 mA	<3
E8462A	256-Ch. Armature MUX	C, 1	Armature	3 $\mu$ V	250 V	—	2 A	<0.5
E2272A	Dual 8 x 1, MUX	M-Mod	DPST, L	<3 $\mu$ V	60 V	>10 MHz	2 A	0.2
<b>RF Multiplexers</b>								
E1366A	Dual 1 x 4, 50 $\Omega$	B, 1	Armature	<6 $\mu$ V	42 V	1.3 GHz	1 A	<1
E1472A/73A	Six 1 x 4, 50 $\Omega$	C, 1	Armature	<6 $\mu$ V	42 V	1.3 GHz	1 A	<1
E1367A	Dual 1 x 4, 75 $\Omega$	B, 1	Armature	<6 $\mu$ V	42 V	1.3 GHz	1 A	<1
E1474A/75A	Six 1 x 4, 75 $\Omega$	C, 1	Armature	<6 $\mu$ V	42 V	1.3 GHz	1 A	<1
E1470A	60-Channel RF Cascade Multiplexer	C, 1	Armature	—	30 V	500 MHz (1 x 3)	400 MA	<1.5 (typical)
<b>Microwave Switches</b>								
E1368A	50 $\Omega$ , 3-Ch. Form C (SPDT) Switch Driver	B, 1	Armature	—	—	18 GHz	—	—
E1369A	Switch Driver	B, 1	—	—	—	Up to 26.5 GHz	—	—
E1370A	Switch/Attenuator Driver	B, 2	—	—	—	Up to 26.5 GHz	—	—
<b>Matrix Switches</b>								
E1361A	4 x 4, 2-wire	B, 1	Armature	<14 $\mu$ V	250 V	10 MHz	1 A	<1.5
E1465A/66A	16 x 16/4 x 64, 2-wire	C, 1	Armature, L	<5 $\mu$ V	200 V	10 MHz	1 A	<1.8
E1467A	8 x 32, 2-wire	C, 1	Armature, L	<5 $\mu$ V	200 V	10 MHz	1 A	<1.8
E1468A	8 x 8, 2-wire	C, 1	Armature	<7 $\mu$ V	220 V	10 MHz	1 A	<1.5
E1469A	4 x 16, 2-wire	C, 1	Armature, L	<7 $\mu$ V	220 V	10 MHz	1 A	<1.5
E2271A	4 x 4 Matrix	M-Mod	DPST, L	<3 $\mu$ V	60 V	>10 MHz	—	0.3
<b>General Purpose Switches</b>								
E1364A	16-Channel Form C (SPDT)	B, 1	Armature	<7 $\mu$ V	250 V	10 MHz	1 A	<1.5
E1442A	64-Ch. Form C/A (SPDT)	C, 1	Armature	<70 $\mu$ V	150 V	10 MHz	1 A	<1.5
E1463A	32-Channel Form C (SPDT)	C, 1	Armature	<7 $\mu$ V	125 V	10 MHz	5 A	<0.25
E2270A	16-Ch. Form A Switch	M-Mod	SPST, L	<3 $\mu$ V	60 V	>10 MHz	2 A	<0.2
E2273A	8-Ch. Form C Switch	M-Mod	Armature	<20 $\mu$ V	60 V	>10 MHz	1 A	—

3499A  
3499B

- Close/open 200 channels in parallel in 0.1 second
- 26 electronic and fiber-optical modules available
- Switching modules with built-in relay cycle counters

- DC to 26.5 GHz, 1mA to 8A, 1mV to 1000V
- Easy wiring with connection kits
- Multi-function modules for space saving



3499A/B front panel

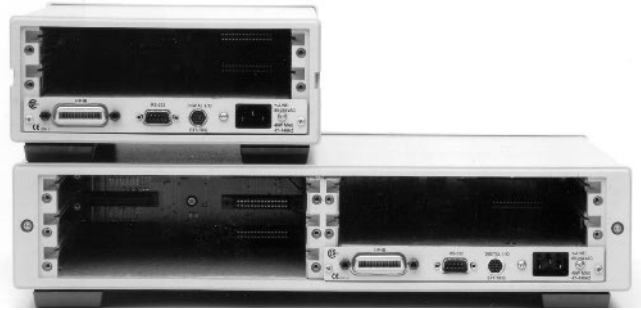

3499A/B front panel

3

## 3499A/B Switch/Control System

The Agilent 3499 family is a high speed, high density, switching solution for electronic/optical automated test (ATE) applications that provides a 30% cost and space savings over its predecessor—the 3488A.

It can scan at rate up to 300 channels per second, or open/close 200 channels in less than 0.1 second. The 3499A can accommodate up to 5 plug-in modules, routing up to 200 channels in a test system. The user can choose from 24 plug-in modules, to switch electronic signals from DC to 26 GHz, 1mV to 1000V, and 1mA to 8A.

The 3499B is a half-rack-width, 2-slot mainframe, switching up to 80 channels in ATE or desktop operations. Both units have a concise user interface that is extremely useful for manual operation on the manufacturing floor or in desktop applications.

### High Speed Switching

While traditional switching mainframes open/close relays in sequence, the Agilent 3499A/B use innovative parallel driving circuits to open/close switches simultaneously. The 3499A can drive as many as 50 channels in 25 ms. With the fast reed relays, the N2266A multiplexer can scan at a speed up to 300 channel/second. The high-speed 3499A/B dramatically increase the test throughput of an automated test system.

### Highly Reliable Switching

The switches are the linkage between the instruments and the DUT, and are the central parts in a test system. Reliability is the most important consideration when designing a switching system. If a low reliable switching system is chosen, it will be the weakest link in your test system, thus increasing your production down cost. When designing the plug-in modules, we provided fail-safe protection circuitry and enough design margin to ensure its high reliability, especially the high current and high voltage switching modules.

## High Density Switches

The Agilent 3499 family allows the user to select a cost-effective configuration for a specific application. Newly designed high density switch modules reduce cost by condensing a large number of channels on a single module. The 3499A contains five slots that accommodate up to 200 switching channels for those large applications on the manufacturing floor. The 3499B contains two slots for switching up to 80 channels, a cost-effective solution for small manufacturing or desktop applications. Both units are designed for easy installation on a standard rack.

### Ease of Maintenance

The built-in relay cycle counters on eleven newly-designed switching modules help you predict relay end-of-life, thereby avoiding costly production line down-time. The relay cycle counter automatically counts every individual relay closure and stores the number in the on-board non-volatile memory. A simple command recalls the total number of cycles for individual relay, making preventative maintenance much simpler.

### Ease of Wiring

The Agilent 3499 family provides two connection kits to reduce the time and effort of wiring. Both the screw connection kits and crimp & insert connection kits are detachable from the switching modules, eliminating the need to rewire the connectors if a switching module is replaced. 3499 is also equipped with DIN96-to-D50 (25) cables for easy attachment to your DUTs and test instruments.

### Applications

The 3499A/B with the diverse plug-in modules are an ideal switching solution for automated test system applications. Typical applications include the production test system of cellular phones, base stations, antennas, pagers, printers, power supplies, optical, and electronic components. You will discover that the Agilent 3499 family is the preferred highly reliable switching solution with its high density plug-in modules, high switching speed, ease of wiring, ease of maintenance, and low cost per channel.

### Plug-in Module Description

#### 40-channel high speed Multiplexer

**N2266A**

The Agilent N2266A is a high speed multiplexer module for high throughput production test system applications, scan speed is up to 300 channel/second. It can be configured as a 1-wire 80-channel, a 2-wire 40-channel, or a 4-wire 20-channel multiplexer.

#### 8-channel 8 A General Purpose

**N2267A**

The N2267A is a highly reliable GP module for high current, low resistance switching applications, such as AC/DC power supply test. It can also be used to switch AC (up to 250V) or DC power supplies, current sources, and line powers.

#### 10-channel 1000 V Multiplexer

**N2270A**

The N2270A is a highly reliable 2-wire multiplexer. It can be used to source voltage up to 1000V to any of ten DUTs or to monitor voltage from different sources with a voltmeter. Applications include capacitor breakdown voltage test and high-resistance measurement of transformers, capacitors, relays, connectors, PCBs and cables.

#### Dual 1 x 4 RF (50 Ω 3.5 GHz) Multiplexer

**N2268A**

The N2268A has two independent 1 x 4 multiplexers with SMA connectors, providing very low insertion loss, high isolation and excellent VSWR performance. The high isolation performance makes this module ideal for RF signal measurements with spectrum analyzers, network analyzers and GSM/CDMA test sets. Each group of four channels is isolated from the other and from the chassis to prevent ground loops. The typical applications include 1.8/1.9 GHz wireless communication device, Bluetooth transceiver and L1/L2 GPS receiver test.

#### 32-bit Isolated DIO+2 DACs

**N2269A**

The N2269A multifunction module is a combination of two DACs, 16-bit digital input and 16-bit digital output. The optically isolated module is designed for industrial automation, it provides excellent signal integrity by eliminating ground noise.

#### 40-channel Multiplexer

**N2260A**

The N2260A can be configured as 1-wire 80-channel, 2-wire 40-channel, dual 2-wire 20-channel, or a 4-wire 20-channel multiplexer for scanning or multiple-signal/instrument connection.

#### 40-channel General Purpose

**N2261A**

The N2261A is ideal for creating isolated control between circuits, providing power control of DUTs, or control of stepping motors and solenoids.

#### 4 x 8 Matrix

**N2262A**

The N2262A provides the most flexible way to connect a group of test instruments to multiple test points on DUTs.

#### 32-bit Digital I/O

**N2263A**

The N2263A, with its 32 TTL compatible digital bits, and 3 handshake lines, can be used to drive/control external devices, to monitor external status, or to communicate with other devices. It provides 3 modes (Static, Strobe, Handshake) for different I/O control applications.

#### 12 + 3 GP + 16-bit Digital I/O

**N2264A**

The N2264A multi-function module is designed for applications that require general purpose relays and up to 3 high current relays (5A maximum) within one module for rack space saving. The 3 high current relays are very useful in applications where a few low resistance channels are needed, such as in cellular phone or battery production test system. There are also 16 bits of Digital I/O on this module.

#### Quad Optical 1 x 2 Multiplexer, SC/APC

**N2280A**

3499A

#### Dual Optical 1 x 4 Multiplexer, SC/APC

**N2281A**

3499B

The 1 x 2 and 1 x 4 optical modules bring the flexibility of modular switching to optical test system. Test engineers can set up an ATE system with just enough optical switching channels to fit the current application, and add more channels later as the application grows. These two modules are ideal for SONET test, fiber-optical component test and fiber network monitoring. These modules are optically passive, and operate independently of data rate, data format and optical signal direction. The SC/APC connectors provide reliable and easy connection to the modules.

#### 4 x 4 Matrix + 16-bit Digital I/O

**N2265A**

The N2265A is designed for applications that require 4x4 matrix and 16 bits digital I/O within one module for rack space saving.

#### 10-channel Multiplexer

**44470A**

#### 20-channel Multiplexer

**44470D**

#### 10-channel General Purpose

**44471A**

#### 20-channel General Purpose

**44471D**

#### Dual 1 x 4 RF Multiplexer

**44472A**

#### 4 x 4 Matrix

**44473A**

#### 16-Bit Digital I/O Module

**44474A**

#### Breadboard

**44475A**

#### 7 Form-C Relay

**44477A**

#### 18 GHz Microwave Switches

**44476A**

#### 1.3 GHz 50 Ω RF Multiplexer

**44478A**

#### 1.3 GHz 75 Ω RF Multiplexer

**44478B**

#### Microwave Relay Driver

**44476B**

This module can drive any following two 876XX coaxial switches. Agilent coaxial switches that can be used are:

Coaxial Switch	Ports	Frequency
<b>8762A, B, C, F</b>	3	4 GHz to 26.5 GHz
<b>8763A, B, C</b>	4	4 GHz to 26.5 GHz
<b>8764A, B, C</b>	5	4 GHz to 26.5 GHz

Notes: The 8762F is for 75 Ω signal switching.

Please choose option 011 when ordering above coaxial switches for the coil voltage of 5 V DC. For details of Agilent 876xx specification, please refer to p/n 5964-9527E.

### 3499A/B Mainframe Specification

**Power Supply:** 100 to 240 VAC universal input; 47 Hz to 440 Hz; 40 VA maximum

**Operating Environment:** 0° C to 55° C, <80% RH (0° C to 40° C)

**Storage Environment:** -40° C to +70° C

**Size:**

3499A: 89mm H x 426mm W x 348mm D (3.5 in x 16.8 in x 13.7 in)

3499B: 89mm H x 213mm W x 348mm D (3.5 in x 8.4 in x 13.7 in)

**Net Weight:**

3499A: 3.8 kg (8.4lbs);

3499B: 2.5 kg (5.5lbs)

**Safety:** Conforms to CSA, UL-1244, IEC 1010 Cat I

**RFI and ESD:** CISPR 11, IEC 80 1/2/3/4

**Slot Capacity:** 3499A: 5 slots; 3499B: 2 slots

**Rear Panel Connectors:** GPIB; RS-232; 8-pin Mini DIN

**Trigger Source:** External (9-pin Mini DIN); GPIB; RS-232

**Built-in 4 digital I/O:** Input: TTL compatible; Vout (H) ≤42V

**Warranty:** 1 year

### Key Literature

Agilent 3499 Switching Family Data Sheet, p/n 5980-2797EN

Please refer to the following table for plug-in modules selection.

Module	Description	Max. voltage per chan.	Max. current	Initial closed channel resistance	Thermal offset per chan.	Bandwidth (-3 dB)	Connection type	Relay cycle counter
<b>Multiplexer modules</b>								
N2266A	40-channel	200 V	0.5	<1 Ω	<50μV	40 MHz	T or C	Yes
N2270A	10-channel	1000 V	1A	<1 Ω	<200μV	5 MHz	Crimp & Insert	Yes
N2260A	40-channel	200 V	1A	<1 Ω	<3μV	10 MHz	T or C	Yes
44470A	10-channel	250 V	2A	<1 Ω	<3μV	10 MHz	T	
44470D	20-channel	250 V	2A	<1 Ω	<3μV	10 MHz	T	
<b>General purpose relay modules</b>								
N2267A	8-channel	250 V	8A	<0.08Ω	<3uV	20 MHz	Crimp & Insert	Yes
N2261A	40-channel	200 V	1A	<0.5Ω	<3uV	10 MHz	T or C	Yes
44471A	10-channel	250 V	2A	<1 Ω	<3uV	10 MHz	T	
44471D	20-channel	250 V	1A	<1 Ω	<3uV	10 MHz	T	
44477A	7-Form C	250 V	2A	<1 Ω	<3uV	10 MHz	T	
<b>Matrix modules</b>								
N2262A	4 x 8 matrix	200 V	1A	<1 Ω	<3uV	10 MHz	T or C	Yes
44473A	4 x 4 matrix	250 V	2A	<1 Ω	<3uV	10 MHz	T	
<b>Digital I/O modules</b>								
N2263A	32-bit TTL	42 V	0.6A	-	-	-	T or C	
44474A	16-bit TTL	30 V	0.125A	-	-	-	T	
<b>Multi-function modules</b>								
N2269A	2 DAC	12V	10mA	-	-	20 KHz	T or C	
	32-bit DIO	TTL Compatible	-	-	3.5MHz	T or C		
N2264A	12 GP	200 V	1A	<0.5 Ω	<3uV	10 MHz	T or C	Yes
	3 GP	125 V	5A	<0.1 Ω	<3uV	10 MHz	T or C	Yes
	16-bit DIO	42 V	0.6A	-	-	-	T or C	
N2265A	4 x 4 matrix	200 V	1A	<1 Ω	<3uV	10 MHz	T or C	Yes
	16-bit DIO	42 V	0.6A	-	-	-	T or C	

Notes: GP = General Purpose; DIO = Digital I/O; T = Terminal Block; C = Cable

Modules	Description	Insertion loss	Stability	Repeatability	Wavelength	Connector	Switching Time
<b>Fiber-optical multiplexer modules (typical specs)</b>							
N2280A	Quad 1 x 2	<0.5 dB	±0.03 dB	±0.003 dB	1310/1550 nm	SC/APC	15 ms
N2281A	Dual 1 x 4	<0.5 dB	±0.03 dB	±0.003 dB	1310/1550 nm	SC/APC	15 ms

Modules	Description	Insertion loss	Cross talk	SWR	Bandwidth	Impedance	Connector
<b>RF &amp; Microwave modules</b>							
N2268A	Dual 1 x 4	<0.35 dB	<-70 dB	<1.20	3.5 GHz	50 Ω	SMA
44472A	Dual 1 x 4	<0.75 dB	<-85 dB	<1.12	300 MHz	50 Ω	BNC
44478A	Dual 1 x 4	<1.1 dB	<-70 dB	<1.35	1.3 GHz	50 Ω	BNC
44478B	Dual 1 x 4	<1.1 dB	<-70 dB	<1.35	1.3 GHz	75 Ω	BNC
44476A	Triple 1 x 2	<0.25 dB	<-90 dB	<1.15	18 GHz	50 Ω	SMA
44476B	Relay driver can support 2 microwave switches. Technical specs depend on the mounted relays.						

## Ordering Information

**3499A** 5 slots full-rack-width Switch/Control Mainframe, includes User's Manual and power cord. Plug-in modules are purchased separately and are required to operate.

**Opt 1CP** Rackmount kit with handles

**Opt 1CM** Rackmount kit

**Opt 0B0** Delete User's Manual

**Opt 0B3** Add Service Manual

**Opt 0B1** Add additional User's Manual

**3499B** 2 slots half-rack-width Switch/Control Mainframe, includes User's Manual and power cord. Plug-in modules are purchased separately and are required to operate.

**Opt 1CM** Rackmount Kit with filler panel

**Opt 0B0** Delete User's Manual

**Opt 0B3** Add Service Manual

**Opt 0B1** Add additional User's Manual

**N2266A** 40-channel high speed Multiplexer

**N2267A** 8-channel 8 A General Purpose

**N2268A** Dual 1 x 4 RF (3.5 GHz) Multiplexer

**N2269A** 32-bit optical isolated DIO+2 DACs

**N2270A** 10-channel 1000 V Multiplexer

**N2260A** 40-channel Multiplexer Module

**N2261A** 40-channel General Purpose Relay Module

**N2262A** 4 x 8 Matrix Module

**N2263A** 32-bit Digital I/O Module

**N2264A** 12 + 3 GP + 16-bit Digital I/O Module

**N2265A** 4 x 4 Matrix + 16-bit Digital I/O Module

**N2280A** Quad 1 x 2 Optical Multiplexer, SC/APC

**N2281A** Dual 1 x 4 Optical Multiplexer, SC/APC

**N2289A** Mini-Din-to-D9 cable for built-in DIO in 3499A/B

**N2290A** Screw Connection Kit for N2260/6A

**N2291A** Screw Connection Kit for N2261A

**N2292A** Screw Connection Kit for N2262A

**N2293A** Screw Connection Kit for N2263A

**N2294A** Screw Connection Kit for N2264A

**N2295A** Screw Connection Kit for N2265A

**N2296A** Crimp & Insert Connection kit for N2260-5A

**N2297A** DIN96-to-Twin-D50 cable for N2260-5A

**N2298A** DIN96-to-D25 cable for 4x8 matrix (N2262A)

**N2299A** DIN96-to-Quad-D25 cable for N2260-5A

**N2320A** Crimp & Insert Connection kit for N2270A

**N2327A** Crimp & Insert Connection kit for N2267A

**N2329A** Screw Connection Kit for N2267A

Plug-in modules (include terminal connectors)

**44470A** 10-channel Relay Multiplexer Module

**44470D** 20-channel Relay Multiplexer Module

**44471A** 10-channel GP Relay Module

**44471D** 20-channel GP Relay Module

**44472A** Dual 4-channel RF Multiplexer Module

**44473A** 4x4 Matrix Switch Module

**44474A** 16-bit Digital I/O Module

**44475A** Breadboard Module

**44476A** Microwave Multiplexer Module

**44477A** Form-C Relay Module

**44476B** Microwave Switch Driver Module

**44478A** 1.3 GHz 50 Ω RF Multiplexer

**44478B** 1.3 GHz 75 Ω RF Multiplex



Agilent offers a full line of interface products to connect your instrumentation and/or VXI mainframe to your PC or workstation. These GPIB interface cards and software make it easy for you to access and control instruments, exchange data, and create your own automated test applications. These GPIB products include:

- GPIB interface hardware and software for PCs
- GPIB interface hardware and software for HP-UX workstations
- LAN/GPIB Gateway for distributed control of GPIB instruments

Agilent also offers PC Automation Kits which provide the hardware, I/O software, and application software you need to automate your bench or lab at the best possible price.

### GPIB Interface Products for PCs

- Plug-in interface cards for personal computers
- SICL/VISA support
- VEE for Windows compatibility
- BASIC for Windows compatibility
- Easy access to test automation
- Wide range of performance and price options

### GPIB Interface Products for PCs

Model	82341C	82341D	82350A
<b>Description</b>	High-performance GPIB interface for ISA bus computers	Plug and Play GPIB interface for PC	High-performance GPIB interface for PCI bus computers
<b>Operating System</b>	Windows 95 Windows 98 Windows NT Windows 2000	Windows 95	Windows 95 Windows 98 Windows NT Windows 2000
<b>I/O Library</b>	SICL, VISA	SICL, VISA	SICL, VISA
<b>Backplane</b>	ISA/EISA	ISA/EISA	PCI
<b>Max. Speed</b>	750 KB/s	750 KB/s	750 KB/s
<b>Buffering</b>	Built-in	Built-in	Built-in
<b>Languages Supported</b>	C/C++, Agilent BASIC for Windows, Agilent VEE for Windows, Visual Basic	C/C++, Agilent BASIC for Windows, Agilent VEE for Windows, Visual Basic	C/C++, Agilent BASIC for Windows, Agilent VEE for Windows, Visual Basic

Some of these products can be purchased online—visit [www.agilent.com](http://www.agilent.com) and search on the product number.

### PC Automation Kits

Agilent's PC Automation Kits provide the hardware, I/O software, and application software you need to automate your bench or lab at the best possible price. The software included is either Agilent VEE, the popular visual programming language, or BASIC, the world's most popular programming language for test and measurement applications.



PC Autokits provide hardware and software in a low-cost bundle

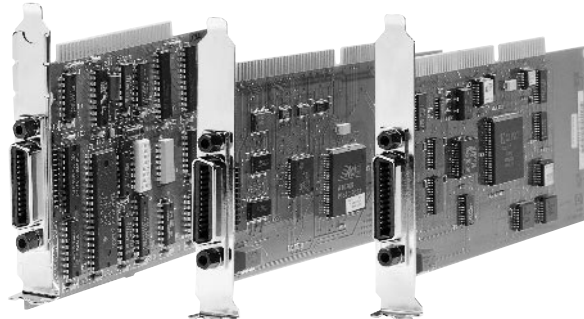

### PC Automation Kits and Products

Model	82345G	82351G	82353G	82346C	82356C
<b>GPIB Interface Card</b>	82341C GPIB ISA card	82350A GPIB PCI card	82350A GPIB PCI card	82341C GPIB ISA card	82350A GPIB PCI card
<b>GPIB Cable</b>	10833B 2 m cable	10833B 2 m cable	10833B 2 m cable	10833B 2 m cable	10833B 2 m cable
<b>Operating System</b>	Windows 95 Windows 98 Windows NT Windows 2000	Windows 95 Windows 98 Windows NT Windows 2000	Windows 95 Windows 98 Windows NT Windows 2000	Windows 95 Windows NT	Windows 95 Windows NT
<b>Software</b>	Agilent VEE Pro for Windows	Agilent VEE Pro for Windows	Agilent VEE OneLab for Windows	Agilent BASIC for Windows	Agilent BASIC for Windows

Some of these products can be purchased online—visit [www.agilent.com](http://www.agilent.com) and search on the product number.

E2071C  
E2071D  
E2078A

## HP-UX Workstation Interface Products

- High-performance GPIB interface cards
- Plug-in instrument control for HP-UX workstations
- VISA and SICL support
- Easy access to test automation

Models	E2071C	E2071D	E2078A
<b>Description</b>	High-performance GPIB interface for HP Series 700	High-performance GPIB interface for HP Series 700	High-performance GPIB interface for PCI bus
<b>Operating System</b>	HP-UX 9.x, HP-UX 10.01	HP-UX 10.20	HP-UX 10.20
<b>I/O Library</b>	SICL, VISA	SICL, VISA	SICL, VISA
<b>Backplane</b>	EISA	EISA	PCI
<b>Maximum Speed</b>	Speed 750 KB/s	Speed 750 KB/s	Speed 750 KB/s
<b>Buffering</b>	Built-in	Built-in	Built-in
<b>Languages Supported</b>	ANSI C, Agilent BASIC, HP-UX, Agilent VEE	ANSI C, Agilent BASIC, HP-UX, Agilent VEE	C/C++, Agilent BASIC, HP-UX, Agilent VEE

3

The E2071C/D and E2078A products include the interface card, I/O software, GPIB cable, GPIB connection extender, and documentation.

## LAN/GPIB Gateway

The E2050A LAN/GPIB Gateway provides low-cost access to GPIB instrumentation over an existing LAN. It allows the use of SICL- or VISA-based applications designed for GPIB over the LAN without modifying the application beyond a simple address change.

The gateway is a combination of hardware and SICL/VISA software. It uses client/server technology to extend the standard remotely on the LAN. This gives you the opportunity to put your controller at an alternative, more convenient, or safer location. Therefore, you can go through the gateway instead of a GPIB interface card.

## Ordering Information

- E2050A** LAN/GPIB Gateway (Cables not included)
  - Opt AG1** I/O software for HP-UX 9.x, 10.x operating system
  - Opt AG6** I/O software for Microsoft Windows 95/98/NT/2000 operating systems
- E2051A** Rackmount Kit for LAN/GPIB Gateway (height is 1U)



The E2050A LAN/GPIB Gateway is easy to use and low cost.

**Test Software**

35639A DataViewer Product Overview

[5962-9499E](#)

37204A Multi-Point GPIB Extender Technical  
Data Sheet

[5962-6971E](#)

**VXIbus Products**

Feeling Comfortable with VXI

[5965-6497E](#)

Test System and VXI Products Data Book

[5966-2812E](#)

Test System and VXI Products Catalog

[5968-3698EN/EUS](#)

VXI Catalog

[5980-0307E](#)

**MMS Products**

71910A Wide Bandwidth Receiver, Technical  
Specifications

[5964-3895E](#)

(PN 71612A) Extending High-Speed BER Testing  
to 20 Gb/s with the 71612A Error  
Performance Analyzer

[5964-6133E](#)

(PN 71612A) 71612A Error Location Analysis

[5968-2811E](#)

(PN 71612A) Testing 10-Gb/s SONET/SDH  
Equipment and Components

[5968-2812E](#)

**System Switches**

(PN 75000) Rigorous Stressing of SONET/  
SDH Alarms Using Programmable  
3-Stage Sequences

[5965-2742E](#)

(PN 75000) Series 95-1 75000 Series 95  
SDH Tributary Test Solutions

[5091-8060E](#)

(PN 75000) Series 95-2 75000 Series 95  
SONET Tributary Test Solutions

[5091-8174E](#)

**Oscilloscopes** Agilent Technologies provides a wide selection of performance from general purpose and troubleshooting, to modular high bandwidth multiple channel instruments, with considerable built-in ease-of-use capabilities.

**Oscilloscope Probes and Accessories** Agilent offers a wide selection of probes and accessories to fit your application, and maximize accuracy of signal reproduction.

**Electronic Counters** Agilent offers the industry's broadest line of electronic counters and counter timers, including Frequency Counters, Universal Counters, and Modulation Domain Analyzers. The breadth of the Agilent offering allows the best product to be selected for each application, and delivers the most cost effective solution.

**Digital Multimeters/Digital Voltmeters** Agilent offers a range of products from 3½ all the way to 8½ digits, with the right functionality and performance to get the job done.

## Data Acquisition and Switching

**Function Generators and Waveform Synthesizers** Agilent not only offers standard functions like sine, square and triangle waveforms, but in addition, Agilent instruments address needs such as multichannel signals, arbitrary waveforms, or even a mix of arbitrary and digital signals.

**dc Electronic Loads** Agilent electronic loads deliver precise control and the capabilities needed for analyzing dc power sources and devices.

**dc Power Supplies** Agilent offers a broad line of system and general purpose power supplies. They include: single- and multiple-output, precision, mobile communications, autoranging, as well as solar array simulators.

**ac Power Source/Analyzers** Agilent's ac power source/analyzers provide everything needed to generate, measure and analyze ac power.

Mixed Signal  
General Purpose  
Digitizing  
Infiniium

High Impedance Passive  
Surface Mount  
Differential  
Active  
High Voltage, Current

Modulation Domain and Time  
Interval Analyzers  
High Performance RF and Universal  
CW Microwave Counter with Power  
Measurement  
Pulse/CW Microwave

Low Cost 6½ Digital Multimeter  
Nanovolt/Micro-ohm Meter  
8½ Digital Multimeter  
Handheld Digital Multimeter  
Accessories

Low Cost Data Acquisition/  
Switch Unit Modules

1 MHz to 21 MHz Synthesizers  
and Function/Sweep Generators  
Multi-functional Synthesizers  
Function Arbitrary Waveform  
Generator

Single-Input Loads  
Modular Mainframes

Modular Power System  
Mobile Communication dc Sources  
Precision Measurement Single-  
Output System  
Multiple-Output System  
Single-Output Systems  
Solar Array Simulators  
Autoranging  
Laboratory

ac Power Source Analyzers  
Regulatory Test Solutions



*See also*  
Frequency & Time  
Standards 504  
VXIbus Products 93

**Oscilloscopes 106**

*See also*  
Digital Communication  
Analyzers 475

**Oscilloscope Probes &  
Accessories 124**

**Modulation Domain  
Analyzers 132**

**Electronic Counters 137**

**Digital Multimeters 145**

*See also*  
LCR & Resistance Meters 494

**Data Acquisition & Switching 154**

**Function Generators &  
Waveform Synthesizers 158**

**DC Electronic Loads 165**

**Power Supplies 169**

**AC Source / Analyzers 192**

*See also*  
Network Analyzers 271

**Additional Literature 194**

## 10 Steps to Selecting the Right Oscilloscope

Since its introduction, the oscilloscope has been one of the most important and most used test and measurement tools. Its capabilities have grown and changed along with electronics technology, and today there are now a multitude of variations in performance and price. As a result, selecting the right one is an important task that can be time-consuming and confusing.

The steps outlined here are intended to speed your selection process and help you avoid possible pitfalls. Whether it's an Agilent scope or one from another vendor, following this process will help you make sure you end up with the right scope for your needs. For a more detailed version, look at the Infiniium scopes web site: [www.agilent.com/find/infiniium](http://www.agilent.com/find/infiniium)

### 1. Analog or Digital?

Analog scopes have familiar front panel controls and are often considered "easy to use." Digitizing oscilloscopes feature a wide range of functionality that cannot be obtained with an analog scope, and recent advances in user interfaces have greatly enhanced usability. As analog-to-digital converters get faster and less expensive with every passing year, the advantage balance continually tilts further toward the digitizing scope, with its increased measurement capabilities and virtually unlimited functionality. Like many T&M manufacturers, Agilent offers only digitizing scopes.

### 2. How Much Bandwidth?

Scope bandwidth is typically defined as the frequency above which a sine wave's amplitude is degraded by more than 3 dB. Trying to look at a signal that's too fast for a scope's bandwidth will introduce errors in amplitude and/or time-interval measurements.

There are two types of bandwidth: repetitive (or equivalent time) bandwidth, and real-time (or single-shot) bandwidth. Repetitive bandwidth applies only to repetitive signals, and the display is built up from samples taken during multiple signal acquisitions. Repetitive bandwidth should typically be at least three times greater than the bandwidth of the signals you want to measure. You can estimate non-sinusoidal bandwidth by the equation  $BW=0.35/\text{your signal's fastest rise-time}$ . Real-time bandwidth is the highest frequency a scope can capture in a single acquisition, and is critical when capturing events that occur infrequently. Real-time bandwidth is tied to sample rate, so if real-time bandwidth is important to you, look carefully at "Sample Rate" in Step 3.

Since more bandwidth usually means more money, you'll want to evaluate the frequency content of the signals you usually view against your budget.

### 3. How Much Sampling Speed ?

There are basically two types of signals you may want to view with a scope: those that occur repetitively and those that happen infrequently. For repetitive waveforms, a scope can either take all the samples in that occurrence (real-time sampling), or take a few samples each time the waveform occurs and combine the samples into a single picture (repetitive sampling). Infrequently occurring events require the scope to capture enough information on a single occurrence of the trigger to accurately represent the waveform. Here's a useful rule of thumb when comparing sample rate and signal bandwidth: if the scope you're looking at has interpolation (filtering to allow reconstruction between sample points), the sample rate to real-time bandwidth ratio should be at least 4:1. Without interpolation, use a ratio of 10:1.

### 4. How Many Channels?

The number of channels you need depends on your application. Two-channel scopes are popular for economical general-purpose troubleshooting. However, if you need to view the relationship of several analog signals you'll want a four-channel instrument. Many engineers working on systems with both analog and digital signals also consider four-channel scopes. Another newer option, called a mixed-signal oscilloscope, combines the channel count and triggering power of a logic analyzer with the greater resolution of an oscilloscope in a single instrument with a time-correlated display.

### 5. How Much Memory Depth?

Memory depth is a measure of how many samples the scope can store. If you need to capture a pulse train without interruption, you'll need a scope with enough memory to capture the whole thing. You can calculate the memory depth you need by dividing the length of time you want to capture by the sample rate needed to reproduce the signal accurately.

Effective triggering, so you capture your signal at the right place, can often reduce the amount of memory your scope really needs. It is also important to understand that deep memory digitizing oscilloscopes are typically more complex to operate. Agilent Technologies has introduced a scope, the 54620 Series, that combines ease-of-use and deep memory for many 100 MHz applications. For higher bandwidth measurements, you'll want to clearly understand possible trade-off between memory depth and ease-of-use.

Memory depth and sampling rate are intimately related. The memory depth you need depends on the overall time span you need to measure and the time resolution you require. Deep memory instruments are more complex to operate because the user must choose the memory depth that reduces "dead time" needed to fill up the extra memory, or display changing signals inaccurately.

### 6. What Kind of Triggering Do I Need?

Many general-purpose scope users get by using edge triggering alone. You may find it helpful in some applications, mainly in troubleshooting new designs, to have additional triggering power. Advanced triggering allows you to isolate events of interest to apply the sampling rate and memory depth most efficiently.

In digital applications, it is very helpful to trigger on a specific pattern across channels. In addition, state triggering allows you to sync up your pattern trigger to a clock edge. Pulse width triggering allows you to trigger on a positive- or negative-going pulse width or extremely narrow pulse. Other trigger capabilities are often available, and it is important to find out how easy they are to set up and use.

### 7. Can You Find Those Elusive Anomalies?

Three primary factors affect a scope's ability to display the unknown and complex signals that you encounter in your daily testing and debugging: screen update rate, peak detect, and triggering power (discussed in Step 6).

Update rate gives you an idea of how quickly your scope can respond to signal and control changes, while peak detect helps you capture fast signal peaks in slower signals. Your best bet is to see the scope performing on YOUR signals and view the update rate and peak detect in action, making sure these features aren't compromised by lack of flexibility in other areas.

### 8. Determine the Analysis Functions You Need

One of the greatest advantages of digitizing oscilloscopes is that they have the ability to make measurements on acquired data and to perform various analysis functions at the touch of a button. The features available vary from vendor to vendor and model to model, but they typically include measurements like frequency, rise time, pulse width, and more. Some digitizing oscilloscopes offer Fast Fourier Transform (FFT) capability as well.

### 9. What about Probing?

It is easy to forget that the probe becomes part of the circuit as soon as it is attached. As a result it introduces resistive, capacitive, and inductive loading, that can cause the scope to show a different measurement than is actually occurring in the unit under test. The goal, therefore, is to have appropriate probes available for different applications and then choose one that will minimize the loading effects, and allow the most accurate replication of the signal.

### 10. Will This Scope Be Easy to Use?

It's pretty obvious—if you can't access the features, or spend too much time learning them, your scope becomes less valuable.



54620 Series Oscilloscopes

### 54620 Series Oscilloscopes

Easily see more in mixed analog and digital designs with

- Unique 2+16-channel mixed signal oscilloscope (MSO) and 2- or 4-channel models
- 2 MB MegaZoom deep memory per channel
- Patented high-definition display maps 2 MB deep memory to show hidden details
- Powerful, flexible triggering including new I<sup>2</sup>C

Model	Bandwidth	Channels	Sample Rate	Memory Depth
54621A	60 MHz	2	200 MSa/s	2 MB/ch
54621D	60 MHz	2 + 16	200 MSa/s	2 MB/ch
54622A	100 MHz	2	200 MSa/s	2 MB/ch
54622D	100 MHz	2 + 16	200 MSa/s	2 MB/ch
54624A	100 MHz	4	200 MSa/s	2 MB/ch

For more information on Agilent 54620 series oscilloscopes, see pages 108–112.

### 500 MHz 54610 Series Oscilloscopes

- High value, general purpose oscilloscopes
- Up to 2 GSa/s sample rate
- Look and feel of analog with the power of digital

Model	Bandwidth	Channels	Sample Rate	Memory Depth
54610B	500 MHz	2	20 MSa/s	4k
54615B	500 MHz	2	1 GSa/s	5k
54616B	500 MHz	2	2 GSa/s	5k

For more information on Agilent 54610 series troubleshooting scopes, see pages 113–115.

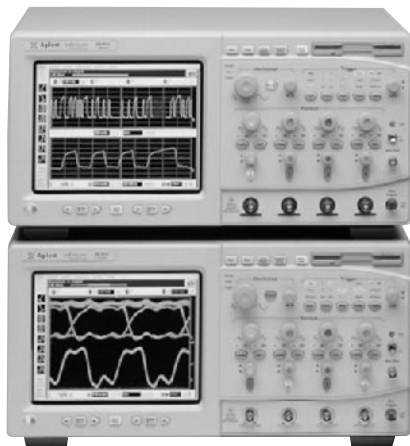

Infiniium Oscilloscopes

### Infiniium Oscilloscopes

- High-performance, low-frustration oscilloscopes
- 500 MHz to 1.5 GHz bandwidth with up to 8 GSa/s sample rate
- Analog-like front panel for simple, understandable operation
- Easy access to advanced features through Windows-based graphical user interface
- Built-in information system and measurement expertise
- New hands-free VoiceControl option

Model	Bandwidth	Channels	Sample Rate	Memory Depth
54810A	500 MHz	2	1 GSa/s	32K
54815A	500 MHz	4	1 GSa/s	32K
54820A	500 MHz	2	2 GSa/s	32K
54825A	500 MHz	4	2 GSa/s	32K
54835A	1 GHz	4	4 GSa/s (2 ch. mode) 2 GSa/s (4 ch. mode)	64K (2 ch. mode) 32K (4 ch. mode)
54845A	1.5 GHz	4	8 GSa/s (2 ch. mode) 4 GSa/s (4 ch. mode)	64K (2 ch. mode) 32K (4 ch. mode)

For more information on the Agilent Infiniium family of scopes, see pages 116–120.

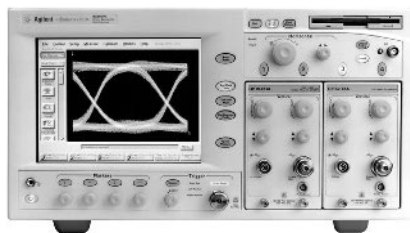

Infiniium DCA Wide-Bandwidth Oscilloscope

### 86100A Infiniium DCA – Wide-Bandwidth Oscilloscope

- Bandwidth to 50 GHz
- 100 Mbs to 10 Gbs and beyond
- Built-in compliance tests
- Integrated optical and electrical channels
- Familiar Windows-based graphical user interface
- Compatible with 83480A/54750A series modules

Model	Bandwidth	Channels	Sample Rate	Memory Depth
86100A	50 GHz	1 to 4	N/A	N/A

For more information on the Agilent 86100A Infiniium DCA, see pages 121–123

### 54750A – Wide-Bandwidth Oscilloscope

- High-bandwidth, high-accuracy oscilloscope
- 12 to 50 GHz bandwidth
- Rich set of features and measurements
- Single-ended and differential TDR

Model	Bandwidth	Channels	Sample Rate	Memory Depth
54750A	12 GHz to 50 GHz	2 or 4	N/A	4 K

54621A  
54621D  
54622A  
54622D  
54624A

Easily see more when debugging mixed analog and digital designs with unique 2+16-channel Mixed Signal Oscilloscope and 2- or 4-channel oscilloscopes with:

- 2 MB/ch MegaZoom deep memory
- Revolutionary new high-definition display system
- Powerful, flexible triggering including new I<sup>2</sup>C
- Built-in Quick Help



54620 Series Oscilloscope

If your designs include both analog and digital components, the new 54620 series oscilloscopes can help you easily see more of what's going on in your designs. The unique 2+16-channel mixed signal oscilloscope (MSO) models and the traditional 2- and 4-channel models are optimized with just the capabilities you need for verifying and debugging mixed analog and digital designs.

	Bandwidth	Channels	Sample Rate	Memory Depth
54621A	60 MHz	2	200 MSa/s	2 MB/ch
54621D	60 MHz	2 + 16	200 MSa/s	2 MB/ch
54622A	100 MHz	2	200 MSa/s	2 MB/ch
54622D	100 MHz	2 + 16	200 MSa/s	2 MB/ch
54624A	100 MHz	4	200 MSa/s	2 MB/ch

All five scopes in the series give you the tools you need to solve your engineering challenges more easily. First, the series offers the configuration you need – 60 or 100 MHz, 2+16-channel, 2- or 4-channel models.

- Each offers 2 MB of MegaZoom deep memory on each channel so you can capture long, non-repeating signals; maintain high sample rate; and quickly zoom in on areas of interest.
- A revolutionary ultra-responsive, high definition display maps the 2 MB of memory to 32 levels of intensity with twice the horizontal resolution and update rates of 25 million vectors per second.
- Flexible triggering lets you easily isolate and analyze the complex signals and fault conditions common in mixed analog and digital designs including edge, pattern, pulse width, TV, and new I<sup>2</sup>C.
- Many other standard features you need such as built-in quick help in 9 languages, 1.44 MB floppy drive, RS-232 and parallel ports for PC/printer connectivity, advanced math functions including FFTs and much more.

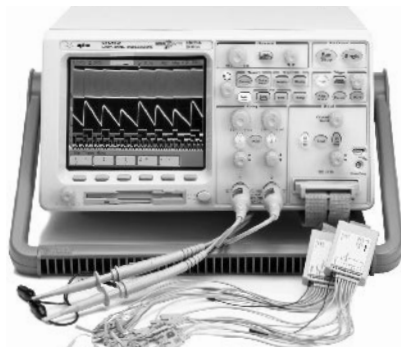

54622D: 2+16-channel Mixed Signal Oscilloscope lets you view fast digital and slower analog signals at the same time.

### 54621D and 54622D Mixed Signal Oscilloscopes (MSO)

The new 60 MHz 54621D and 100 MHz 54622D MSOs are perfect for designs based on 8- or 16-bit microcontrollers. With 2 analog channels and 16 digital channels, these scopes uniquely combine the detailed signal analysis of a scope with the multi-channel timing measurements of a logic analyzer. They let you see the complex interactions among your signals on up to 18 channels at the same time. No more guesswork and no more poking around to see a few channels at a time. These scopes can easily conquer mixed analog and digital debugging problems that a traditional scope can't begin to address, because they let you simultaneously test and monitor the high-speed digital control signals and the slower analog signals in your design. The combination of analog channels, digital timing channels, and 2 MB MegaZoom deep memory with triggering across all 18 channels provides totally new ways to debug mixed analog and digital 8- or 16-bit microcontroller-base designs. Plus the MSOs are easy to use as they are built on the 54600 scope foundation with improved usability.

### 54624A 4-Channel Scope

If your designs include heavy analog content, the 100 MHz 54624A will give you the channel count and measurement power you need, including 2 MB/ch MegaZoom deep memory, high definition display, and flexible triggering. Whether you are testing designs with four inputs such as anti-lock brakes, or monitoring multiple outputs of a power supply, the 4-channel model helps you get your debug and verification done with ease.

### 54621A and 54622A 2-Channel Scopes

The two-channel models bring all the benefits of MegaZoom deep memory, high-definition display, and flexible triggering to those value-minded designers with lower channel requirements. Available in both 60- and 100-MHz models, these scopes give you an affordable way to see long time periods while maintaining high sample rate so you can see details in your designs.



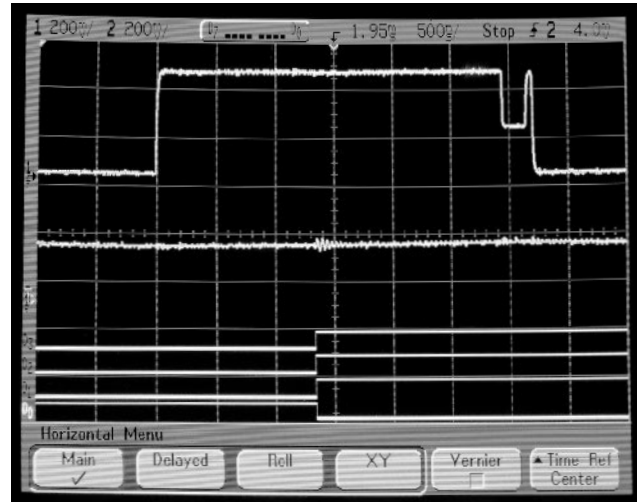
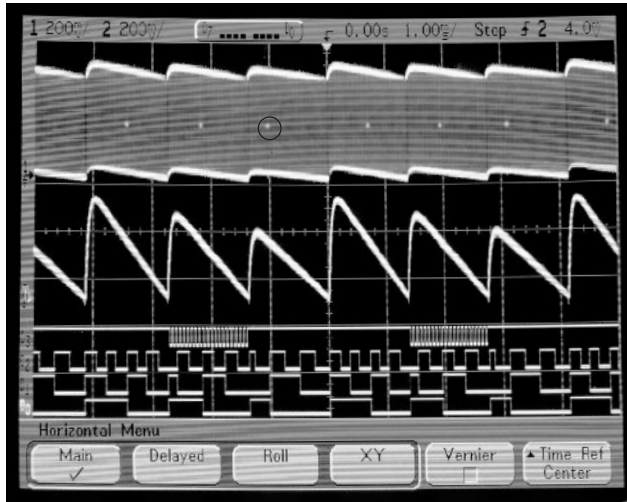

The bright dot on the high definition display is a distortion in one of the 1,500 pulses captured in this single shot measurement. Simply dial in for a closer look using MegaZoom pan and zoom and you'll see the details that would have escaped other scopes.

### MegaZoom Deep Memory

With 2 MB of MegaZoom deep memory behind every channel, the 54620 series scopes give you deep memory capture without the sluggish response and complex operation you have had to tolerate with other deep memory scopes. And unlike the alternatives, MegaZoom deep memory is not a special mode; it operates with the same familiar controls you use for regular scope measurements. That means it is always available to help you do a better job finding details buried in complex signals, discovering anomalies in the absence of good trigger events, correlating high-speed digital with slower analog signals and capturing infrequent events.

The dilemma of having to do two captures to get a long time capture or to see detailed resolution is solved with MegaZoom deep memory as you can have both with a single measurement. Deep memory means that the sample rate can be kept high even when you capture long time periods. You will have a hard time finding another scope that easily lets you collect 10 milliseconds of data with the ability to see 5 nanosecond details like you can with MegaZoom deep memory.

### Revolutionary High-Definition Display

When you combine MegaZoom deep memory with a new patented high-definition display system, you get an accurate and responsive "window into your world." The 2 MB/ch MegaZoom deep memory is mapped into 32 levels of intensity on a display that has superior horizontal resolution. And with a screen update rate of 25 million vectors/sec, you get a responsive display that reflects changes in your waveform instantaneously—so you see a more realistic representation of your signals.

### Flexible Triggering

With mixed analog and digital designs, sometimes it is hard to trace an anomaly back to its root cause unless you can trigger on it and correlate it with other signals. The new 54620 series scopes come with flexible triggering including edge, pulse width, pattern, TV, sequence, duration, and I<sup>2</sup>C across all channels. You can easily isolate and analyze complex signals and interactions.

### Standard Features

The 54620 series scopes include the standard features you need to get your job done easier and faster.

#### Connectivity Made Easy

- Parallel and RS-232 interfaces make connection to printers and PCs a snap. These scopes all come with standard parallel and RS-232 interfaces on the rear panel. For faster data transfer, an optional GPIB interface module (N2757A) is available.
- BenchLink XL, a free software application, simplifies PC connectivity when you need to transfer images and waveform data to your PC. BenchLink XL software lets you insert a snapshot of the scope screen directly into your Microsoft Excel spreadsheets or Word documents at the click of a button on your PC.

#### Built-in Floppy Drive

A built-in 1.44 MB floppy drive makes it easy to store waveform data, screen images, or scope setups. You can store waveform images as TIF or BMP files and you can store waveform data as ASCII files for easy import into other PC applications. If you share your lab equipment with others you can save your setups and traces to diskette, making it easy to reproduce your setups.

54621A  
54621D  
54622A  
54622D  
54624A

54621A  
54621D  
54622A  
54622D  
54624A

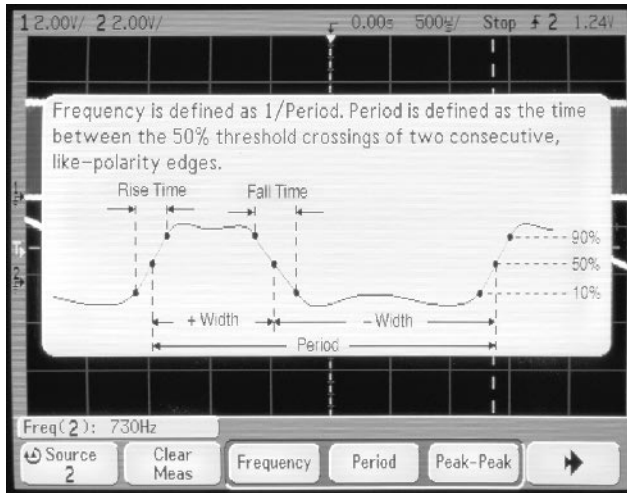

Press and hold any key for built-in Quick Help in 9 languages

### 4

#### Built-in Quick Help

An innovative built-in quick help system in 9 different languages (English, French, German, Spanish, Italian, Japanese, Korean, Traditional, and Simplified Chinese) gives you quick access to the help you need. If you have a question about a particular feature, simply press and hold the corresponding front-panel key for a few seconds and a help screen pops up to explain its function.

#### Other Standard Features Include:

- Waveform math including FFTs, integrate, differentiate, -, and \*
- 5-ns peak detect means you won't have to worry about missing narrow glitches.
- Autoscale lets you quickly display any active signals, automatically setting the vertical, horizontal, and trigger settings for best display
- High resolution mode offers up to 12 bits of resolution in single shot mode, significantly reducing noise by averaging.
- Printer connectivity is easy to DeskJets, LaserJets, or the optional integrated thermal printer in a pouch (N2727A).
- 3-year warranty is standard with optional 5-year warranty coverage.

For more information, visit our web site at [www.agilent.com/find/megazoom](http://www.agilent.com/find/megazoom)



Scope with array of probes

#### Complete Line of Probes and Accessories

To get the most out of your scope, you need the right probes and accessories for your particular applications. Quality scope probes and accessories can improve measurement results while minimizing setup time and overall frustration. Call the measurement specialists at Agilent or visit our web site: [www.agilent.com/find/gp](http://www.agilent.com/find/gp) for information on our comprehensive array of scope accessories including passive probes, differential probes, current probes, and the innovative Wedge probe adapter.

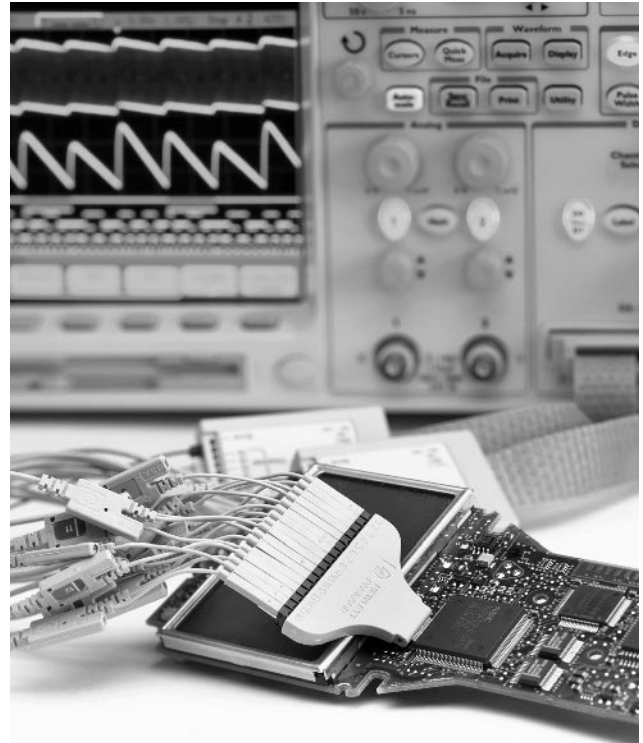

16-pin Wedge probe adapter is perfect for probing fine pitch 0.5 mm or 0.65 mm ICs.

	54621A	54622A	54624A	54621D	54622D
<b>Channel</b>	2 scope	2 scope	4 scope	2 scope+16 logic	2 scope+16 logic
<b>Scope</b>					
Bandwidth	60 MHz	100 MHz	100 MHz	60 MHz	100 MHz
Channels	2	4	2	2	2
Sample Rate	200 MSa/s	200 MSa/s	200 MSa/s	200 MSa/s	200 MSa/s
Max input (dc+peak ac)	400 V	400 V	400 V	400 V	400 V
Resolution	8 bits	8 bits	8 bits	8 bits	8 bits
High Resolution Mode	12 bits when > 200 us/ div (ave mode)	12 bits when > 200 us/ div (ave mode)	12 bits when > 200 us/ div (ave mode)	12 bits when > 200 us/ div (ave mode)	12 bits when > 200 us/ div (ave mode)
Range (per division)	1 mV to 5 V	1 mV to 5 V	1 mV to 5 V	1 mV to 5 V	1 mV to 5 V
<b>Logic</b>					
Channels	n/a	n/a	n/a	16	16
Sample rate				400 MSa/s	
Input level				500 mVp-p min; ±40 V max	
<b>Memory</b>					
Scope Channels	2 MB/channel MegaZoom deep memory				
Logic Channels					
Single pod active				8 MB/ch	
Dual pod active				4 MB/ch	
<b>Timebase</b>			5 ns/div to 50 s/div		
<b>Peak Detect</b>			5 ns		
<b>Triggering</b>	Edge, pattern, pulse width, TV, sequence, I <sup>2</sup> C, duration External trigger and trigger out				
<b>Display</b>	High definition with 32 levels of intensity; 1,000 points horizontal resolution				
<b>Display Update Rate</b>	Up to 25,000,000 vectors per second per channel				
<b>Display Modes</b>	Normal, average, peak detect, roll, XY with Z-blanking				
<b>Measurements</b>	Peak-to-peak, maximum, minimum, average, amplitude, top, base, overshoot, undershoot, RMS, frequency, period, + width, – width, duty cycle, time at max, debug, phase				
<b>Standard Math Functions</b>	FFT, differentiate, integrate, subtract, multiply				
<b>Storage</b>	Built-in 1.44 MB floppy drive				
<b>Connectivity</b>	Standard RS-232 and parallel on rear panel; optional GPIB interface module (N2757A)				
<b>Built-in Quick Help</b>	Quick Help at press/hold of any key in 9 languages				
<b>Warranty</b>	3 years standard, optional increase to 5 years				
<b>Size/Weight</b>	17.27 cm H x 32.26 cm W x 31.75 cm D (6.09 in x 14.1 in x 12.5 in); 6.35 kg (14 lb)				

For complete specifications ask for data sheet, or visit our web site at [www.agilent.com/find/megazoom](http://www.agilent.com/find/megazoom)

54621A  
54621D  
54622A  
54622D  
54624A

54621A  
54621D  
54622A  
54622D  
54624A

## Ordering Information

**54621A** 2-channel 60 MHz Oscilloscope  
**54621D** 2+16-channel 60 MHz Mixed Signal Oscilloscope  
**54622A** 2-channel 100 MHz Oscilloscope  
**54622D** 2+16-channel 100 MHz Mixed Signal Oscilloscope  
**54624A** 4-channel 100 MHz Oscilloscope

Accessories Included	54621A	54621D	54622A	54622D	54624A
User's Guide (localized), Service Manual, and Programmer's Manual	•	•	•	•	•
Power cord	•	•	•	•	•
10074C 10:1 probes with readout	2	2	2	2	4
16:2 x 8 input logic probe		•		•	
Accessories pouch and front panel cover			•	•	•
BenchLink XL software and RS-232 cable			•	•	•

Note: BenchLink XL is available free from the web site: [www.agilent.com/find/gp](http://www.agilent.com/find/gp)

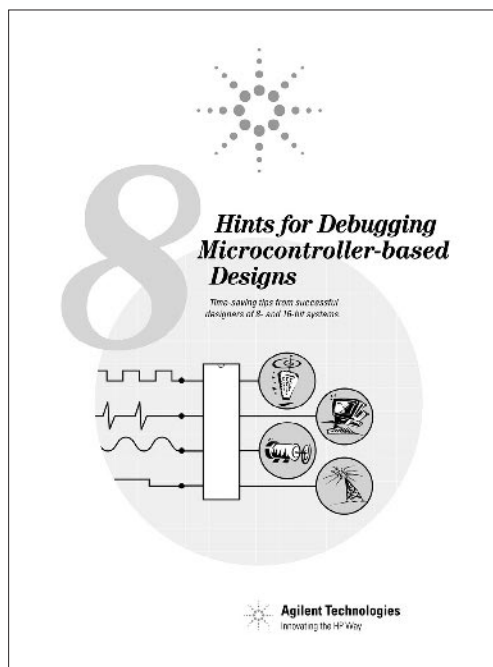

Ask for your free copy of debugging tips from successful designers of 8- and 16-bit systems.

**Manual Options:** ABA (English), ABD (German), ABE (Spanish), ABF (French), ABZ (Italian), ABJ (Japanese), AB0 (Traditional Chinese), AB1 (Korean), AB2 (Simplified Chinese)

### Available Options

- Opt 003** Shielding option for use in severe environments or with sensitive devices under test—shields both ways: RS-03 magnetic interface shielding added to CRT and RE-02 display shield added to CRT to reduce radiated interference
- Opt 0B0** Delete manuals
- Opt 1CM** Rack mount kit (or part number 1186A)

### Warranty and Calibration Options

All models include standard 3-year warranty. Contact local sales Agilent office for prices of extended options:

- Opt A6J** ANSI/NSCL Z540 calibration with test data (replaces 1BP)
- Opt W32** 3-year Customer-return calibration service
- Opt W34** 3-year, Customer-return standard comp cal service
- Opt W50** Additional 2-year warranty (5 year total)
- Opt W52** 5-year Customer-return calibration service
- Opt W54** 5-year Customer-return standard comp cal service

### Accessories

- Opt 1183A** Testmobile scope cart
- Opt 1185A** Hardshell carrying case
- Opt 1186A** Rack mount kit (or option 1CM)
- Opt N2726A** Accessories pouch and front panel cover (standard with 100-MHz models, optional for 60-MHz models)
- Opt N2727A** Integrated thermal Seiko printer in a pouch (parallel cable, power cable, extra paper, front panel cover)
- Opt N2728A** 10 rolls of thermal printer paper
- Opt N2757A** GPIB interface module for 54621A/D, 54622A/D, or 54624A

### Probes

See the complete line of passive, current, high voltage, differential probes, and fine pitch probing accessories including the Agilent Wedge in the probes and accessories section on page 124.

For an interactive demo, visit our web site: [www.agilent.com/find/megazoom](http://www.agilent.com/find/megazoom)



- Analog look and feel
- 500 MHz bandwidth
- Up to 2 GSa/s sample rate
- 1 ns peak detect

54610B  
54615B  
54616B

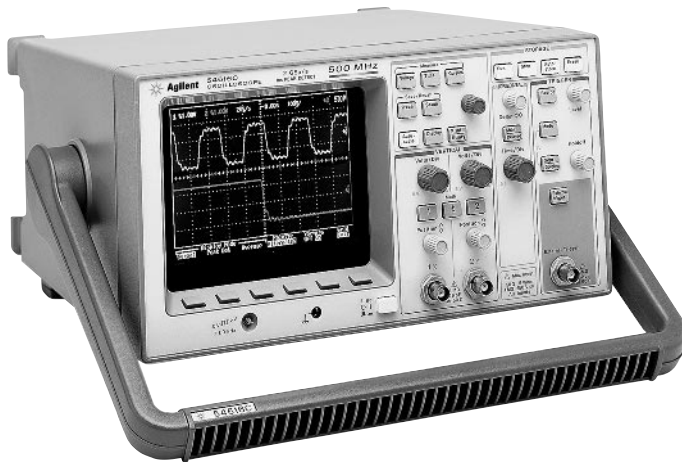

### 54610 Series of Oscilloscopes

When you need the bandwidth to handle demanding applications and want the flexibility to choose the one troubleshooting scope that is ideal for your lab, there is a 500 MHz scope in the Agilent 54610 Series to meet your needs. This 500 MHz series of scopes gives you the familiar controls and interactive displays you've grown accustomed to. To solve your most difficult problems, these scopes provide powerful digital features, such as autoscale, pre-trigger viewing, peak detect, waveform storage, and automatic measurements such as Vpp and frequency.

#### Value-Priced 500 MHz Scopes

The Agilent 54610B is the lowest priced 500 MHz oscilloscope on the market, but it does not compromise on measurement quality. You get  $\pm 0.01\%$  horizontal accuracy and a maximum display update rate of 1.5 million points per second.

The 54615B boosts the sample rate to 1 GSa/s while preserving the intuitive analog feel and instantaneous response. With horizontal accuracy of  $\pm 0.005\%$  and horizontal resolution of 20 ps, you will

uncover details that hide from slower scopes. For even more signal detail, the 54616B doubles the sample rate to 2 GSa/s, delivering a single-shot bandwidth of 500 MHz.

Agilent uses a multiple-processor architecture in the 54610 series to deliver ease of use with a responsive high-update-rate display. The parallel processing utilized in the 54610 series allows acquisition and display systems of the oscilloscope to function independently of human interface and measurement systems. This makes for a general purpose troubleshooting scope that is responsive to changes in your waveform as well as changes in the front panel settings.

For PC or printer connectivity, add a GPIB or RS-232/parallel interface module. The measurement storage interface modules also add extra functionality such as FFTs and mask testing to speed your problem solving.

Model	Bandwidth	Chs	Sensitivity	Sample Rate
54610B	500 MHz	2	2 mV to 5 V/div	20 MSa/s
54615B	500 MHz	2	2 mV to 5 V/div	1 GSa/s
54616B	500 MHz	2	2 mV to 5 V/div	2 GSa/s

54610B  
54615B  
54616B

- Hard copy output to printer or plotter
- Free BenchLink XL 54600 software for easy PC connectivity
- Remote instrument control
- Enhanced automatic measurements, FFT, mask testing



### A Full Family of Add-On Interface and Enhancement Modules

The Agilent 54610 series scopes use a complete range of optional interface modules for hard copy output, remote programmability, and added functionality including mask testing and FFTs. These modules plug into the back of the 54610B, 54615B or 54616B scopes.

#### 54650A GPIB Interface Module

This module provides full computer remote control via a GPIB interface connection in accordance with IEEE-488.2.

**Specifications:** The interface capabilities of the 54610B, 54615B or 54616B/C scopes with this module installed are defined by IEEE-488.1 as SH1, AH1, T5, L4, SR1, RL1, PP1, DC1, DT1, C0 and E2.

#### 54652B RS-232/Parallel Interface Module

This module provides computer interface via RS-232 and printing via the parallel interface in one module.

**Specifications:**

**Connector Type:** 9 pin (m) DTE port, works with 34398A cable

**Protocols:** Xon/Xoff, hardware; 8 data bits; parity none

**Baud Rates:** 1200, 2400, 9600, or 19200

**Supported printer protocols:** HP PCL (DeskJet or LaserJet), HP-GL compatible plotters, Epson FX-80

#### 54657A GPIB and 54659B RS-232/Parallel Measurement/Storage Modules

With the addition of either the 54657A GPIB module or the 54659B RS-232 and parallel module, the 54610B, 54615B or 54616B scopes will have added capabilities:

**More Automatic Measurements:**

Complementing the standard set of automatic measurements, these modules add phase, delay, Vpre and Vovershoot, plus user definable thresholds: select from 10/90%, 20/80% or absolute voltage levels.

**Waveform Math Functions:**

**Function 1:** addition, subtraction, and multiplication

**Function 2:** FFT, differentiation, integration

**FFT windows:** exponential, flat top, Hanning and rectangular

**FFT sample:** 1024 points

**Storage:**

**Trace memory:** up to 100 nonvolatile memories

**Real-Time Clock:** 24 hour format with battery back-up

**Mask Testing:**

**Testing Method:** Comparison to waveform mask

**Number of Masks:** 2

**Mask Generation and Operations:** Automask, controlled from the front panel, generates mask from displayed waveform with selectable tolerance.

Mask editor function allows pixel-by-pixel editing.

**54657A:** GPIB (see specifications for 54650A)

**54659B:** RS-232 and parallel interfaces (see specifications for 54652B)

### BenchLink XL 54600 Software (free)

#### PC Connectivity Made Easy

Receive BenchLink XL software FREE with the purchase of any RS232/Parallel or GPIB interface module. Use it to retrieve waveform images, waveform data—even automatic measurements—directly into Microsoft Excel and Word without programming. Additionally, an ActiveX control simplifies programming in Visual Basic, VBA, Visual C++, Agilent VEE, and National Instruments LabVIEW.

### 34810B BenchLink Scope Windows Software (Option 106)

BenchLink Scope is a standalone optional software package that makes it easy to move important information from a 54610B, 54615B, or 54616 B/C scope to your PC. You'll be able to:

- Transfer a bitmap picture of the scope display to your PC for viewing as TIF formats
- Transfer the actual waveform data to your PC for further review and analysis. Instrument setup can be saved to the PC for transfer back to the scope

### Enhanced Performance for Video Applications (Option 005)

With the addition of Option 005, enhanced TV/video triggering, to the 54610B, 54615B, 54616B oscilloscopes, you will be able to trigger on any specified line of video in either NTSC, PAL, PAL-M, SECAM or generic video formats. With this additional triggering, you will be able to easily view signals that are often very dim or invisible on most analog scopes. Once you have the signal of interest displayed, you can measure it with digital precision.

## 54610-Series Scope Interface and Enhancement Modules

**Ordering Information**

Product	Description	GPIB	RS-232 and Parallel	FFT and Advanced Meas.	BenchLink XL Software (free)	BenchLink Scope Software
1. 54650A 54652B	GPIB Interface Module RS-232 and Parallel Interface Module	•	•		•	
2. 54657A 54659B	GPIB Measurement/Storage Module RS-232 Measurement/Storage Module	•	•	•	•	
3. E2657A E2659A	Measurement/Connectivity Kit for GPIB Measurement/Connectivity Kit for RS-232	•	•	•	•	•

**1. Basic Connectivity**

If all you need is a PC interface, add GPIB with the 54650A or both RS-232 and parallel connections with the 54652B. BenchLink XL 546000 Software ships free with all modules.

**2. Connectivity and Advanced Measurements**

For high-performance tools usually found only in much more expensive scopes—including FFTs to view signals in the frequency domain—add the 54657A (GPIB) or 54659B (RS-232 and parallel) measurement/storage module.

**3. Complete Connectivity, Including Software**

Get the complete package, including measurement storage module, BenchLink Scope standalone software and appropriate cable for documenting and analyzing measurement results.

### Product Specific Performance Characteristics

Vertical system	54610B	54615B	54616B
Bandwidth (BW) Channels	dc to 500 MHz 2	dc to 500 MHz 2	dc to 500 MHz 2
Input R & C	1 M $\Omega$ , ~9 pF	1 M $\Omega$ , ~9 pF	1 M $\Omega$ , ~9 pF
Dynamic range (from center screen)	$\pm$ 12 divisions	$\pm$ 12 divisions	$\pm$ 12 divisions
Sensitivity (per division) Ch. 1 and 2	2 mV to 5 V	2 mV to 5 V	2 mV to 5 V
Accuracy	$\pm$ 2% of full scale	$\pm$ 2% of full scale	$\pm$ 2% of full scale
Maximum input dc + peak ac	250 V or 5 V RMS in 50 $\Omega$ mode	250 V or 5 V RMS in 50 $\Omega$ mode	250 V or 5 V RMS in 50 $\Omega$ mode
Selectable BW limit	30 MHz	30 MHz	30 MHz
<b>Horizontal system</b>			
Accuracy	$\pm$ 0.01% of full scale	$\pm$ 0.005% of full scale	$\pm$ 0.005% of full scale
Resolution	25 ps	20 ps	20 ps
Delay jitter	10 ppm	1 ppm	1 ppm
Sweep speed	5 s/div to 1 ns/div	5 s/div to 1 ns/div	5 s/div to 1 ns/div
<b>Acquisition system</b>			
Max. sample rate	20 MSa/s	1 GSa/s	2 GSa/s
Single shot BW	2 MHz	250 MHz	500 MHz
Peak detect	50 ns	1 ns	1 ns
Record length (pts. vectors off/on)	4k/2k	5k/2k	5k/2k
Max. update rate vectors off	1.5 M pts/s	0.5 M pts/s	0.5 M pts/s
<b>Trigger system</b>			
Sensitivity Ch. 1 and 2	dc to 25 MHz, 0.35 div or 3.5 mV dc to 500 MHz, 1 div or 10 mV	dc to 100 MHz, 0.5 div or 5.0 mV dc to 500 MHz, 1 div or 10 mV	dc to 100 MHz 0.5 div or 5.0 mV dc to 500 MHz, 1 div or 10 mV
External trigger range	$\pm$ 18 V	$\pm$ 2 V	$\pm$ 2 V
External trigger input maximum input	250 V (dc + peak ac) 5 V rms in 50 $\Omega$	250 V (dc + peak ac) 5 V rms in 50 $\Omega$	250 V (dc + peak ac) 5 V rms in 50 $\Omega$
<b>Measurements</b>	Over 15 automatic measurements including Vpp, Vavg, Vrms, Frequency, Period, $\pm$ Pulse width, Rise/Fall time		
<b>Math functions</b>	+, -, invert, *, FFT, integrate, differentiate with optional measurement storage module		
<b>Printer/computer</b>	with optional RS232/Parallel or GPIB modules, receive free BenchLink XL Software support		

### Ordering Information

**54610B** Two-Channel 500-MHz Oscilloscope  
**54615B** Two-Channel 500 MHz Oscilloscope  
**54616B** Two-Channel 500 MHz Oscilloscope  
 All 54610 Series scopes ship with two 1.5m 10X probes (10073A), operating and service guide, and line cord

### Accessories

**1183A** Scope cart (Testmobile)  
**1185A** or Option 104 hardshell carrying case  
**1186A** or Option 1CM rack mount kit (7" EIA standard)  
**54650A** GPIB interface module\*  
**54652B** RS-232 and parallel interface module\*  
**54657A** Measurement/storage module with GPIB interface\*  
**54659B** Measurement/storage module with RS-232 and parallel\*  
**E2657A** Measurement/connectivity kit for GPIB  
**E2659A** Measurement/connectivity kit for RS-232  
 \*Modules ship with free BenchLink XL 54600 Software

### Options

**Opt 001** Display EMI shield (54600-68703)  
 Provides extra shielding for the CRT, for MIL standards or harsh magnetic environments  
**Opt 002** Display filter (54600-68704)  
 Provides additional reduction in radiated emissions, for MIL standards or measurement environments sensitive to radiated emissions  
**Opt 005** Enhanced video trigger  
 Adds the ability to trigger on a specified line of NTSC, PAL, PAL-M, SECAM, or general format video. IRE graticule, IRE cursor readout, video autoscale, and rear-panel outputs for trigger and channel input are added with this option  
**Opt 101** Accessory pouch and front-panel cover (10098A)  
**Opt 106** BenchLink XL software (34810B)  
 Windows software that interfaces the scope (via GPIB or RS-232 module) to a PC for storage, analysis, or easy integration of waveform data into desktop publishing software  
**Opt 090** Delete probes  
**Opt W50** Additional two-year warranty (for a total of five years)

### For the Educators

These oscilloscopes are ideally suited for classroom use. Contact the Agilent Call Center in your region for details on specific education discount programs.

 Indicates QuickShip availability.



54610B  
54615B  
54616B

# Oscilloscopes

## Infiniium Oscilloscopes

54810A  
54815A  
54820A  
54825A  
54835A  
54845A

- 500 MHz, 1 GHz and 1.5 GHz bandwidth
- 2- or 4-channel models
- Up to 8 GSa/s sample rates
- Simple, analog-like front panel
- Windows-based graphical user interface
- Built-in information system
- VoiceControl option



### Performance You Can Use

Infiniium oscilloscopes combine a simple, analog-like front panel, a familiar Windows-based graphical user interface, and a built-in information system, to make high-performance scope features easy to access. We call it usable performance. We think you'll call it a significant improvement.

### Simple Analog-like Front Panel

Dedicated scale and offset knobs for each vertical channel, color coded with the waveform colors, provide intuitive scope operation. Backlit LEDs on the front panel show at a glance how the scope is set up. A single QuickMeas button gives you four of your favorite measurements with statistics at the push of a button.

### Familiar Graphical User Interface

Infiniium oscilloscopes employ a Windows-based graphical user interface. Pull down menus give you easy access to advanced features. And, many advanced features can be used without accessing the menus. For instance, drag-and-drop measurements, direct control of the waveforms, and zooming in on an area of interest can easily be performed using a standard mouse or any PS/2 pointing device.

### LAN Connectivity

Infiniium makes it easy to document and share your results with others. Simply print out screen images to high quality color printers connected to your network. You can also share screenshot files with other Infiniium users. Or mount Infiniium's hard disk drive to your PC over the network to easily transfer files for analysis or documentation. And now, Infiniium can also be controlled with GPIB strings over LAN.



### Internal Hard and High Capacity Floppy Disk Drives

Use the internal 3.2 GB hard disk drive or the 3.5-inch LS-120 120 MB floppy disk drive (compatible with standard 1.44 MB floppies) to store instrument setups, waveforms, or screen images. Images can be stored as BMP, TIF, GIF, PCX, PS or EPS files to disk or transferred over the LAN, for easy import into various documentation programs.

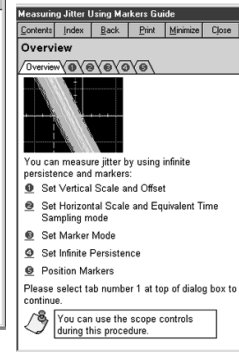

Built-in measurement expertise: Infiniium's task-oriented Setup Guide is designed around the way you work. You'll find step-by-step instructions for more than 20 different advanced measurements and procedures.

### Built-in Information System

Infiniium's built-in information system puts measurement assistance at your fingertips. A Setup Guide walks you step-by-step through making more than 20 common complex measurements like jitter and runt triggering. In addition, context-sensitive help is available to define all features available in the Windows dialog boxes.



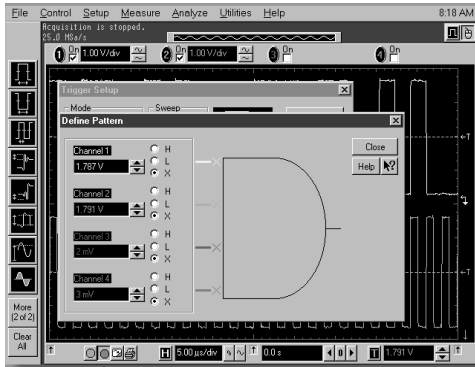

Graphical dialog boxes make it easy to set up Infiniium's powerful triggering capability.

### Advanced Triggering

In addition to the standard trigger modes such as edge, glitch, pattern, state, delay, video and line, Agilent's violation trigger adds capabilities such as runt trigger, setup/hold time trigger, pulse width trigger, and transition trigger to capture those elusive violations. And, Infiniium's graphical dialog boxes make it easy to set up advanced trigger conditions.

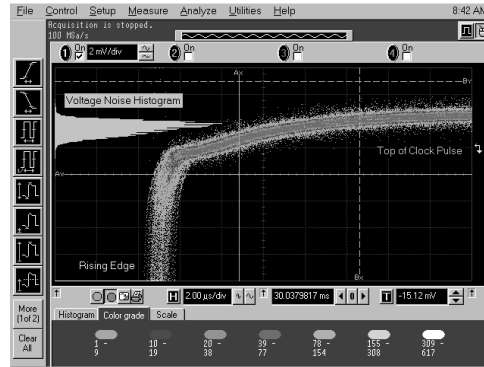

Color-grade persistence makes it easy to pick out signal anomalies.

### Color-grade persistence and histograms

Color-grade persistence provides a colorful, visual representation of waveform distribution, which makes it easy to pick out signal anomalies and see how often they occur. Histograms quantify both noise and jitter in your system.

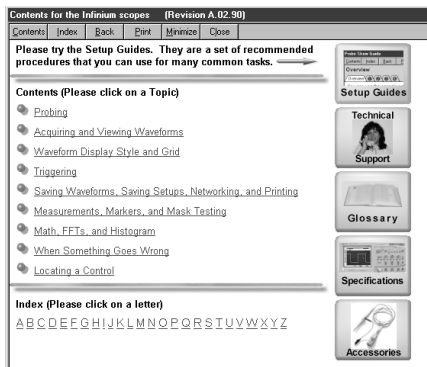

Remotely display and control your Infiniium over the web.

### Web-Enabled Connectivity and E-mail on Trigger



The new web-enabled connectivity feature allows you to remotely display and control your Infiniium from any java-enabled web browser over the built-in LAN interface. In addition, if you set up your Infiniium to trigger on an intermittent event, it can send you an e-mail with a bitmap of Infiniium's screen when the trigger event occurs. Now you don't have to be in your lab to view and control Infiniium.

- 54810A
- 54815A
- 54820A
- 54825A
- 54835A
- 54845A

54810A  
54815A  
54820A  
54825A  
54835A  
54845A

- Over 20 industry standard ANSI T1.102, ITU-T G.703 and IEEE 802.3 communication masks
- Mask testing for positive and negative pulses
- Electrical communication adapters optimized for use with Infiniium oscilloscopes
- Automatic “isolated ones” triggering for all pulse masks
- One button alignment of mask to signal
- Single dialog box sets up the pass/fail test

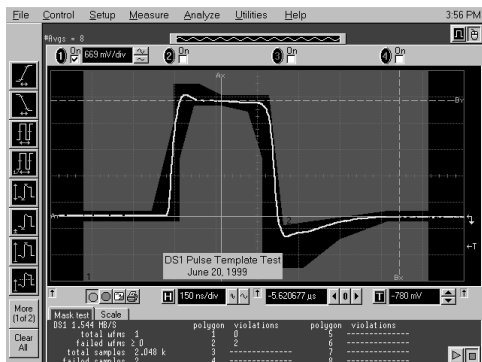

Mask Testing

### Option 100—Communication Mask Test Kit

Perform compliance testing to ANSI, ITU-T and IEEE standards with Infiniium’s Communication Mask Library and electrical communication adapters.

For more detailed information on Option 100, refer to the Infiniium Mask Test Kit datasheet (p/n 5968-9625).



The Option 100 kit includes a set of adapters to assure convenient, reliable and accurate connections to your DUT.

### Communication Mask Library

Standard	Mask Template	Data Rate (Mb/s)
ANSI T1.102	DS1	1.544
	FCC Part 68.308 Opt. B,C	1.544
	DS1A	2.048
	DS1C	3.152
	DS2	6.312
	DS3	44.736
	STS1 (pulse)	51.840
	STS1 (eye)	51.840
	DS4NA (eye)	139.264
STS3 (eye)	155.520	
ITU-T G.703	DS1	1.544
	E1	2.048
	DS2	6.312
	E2	8.448
	E3	34.368
	DS3	44.736
	E4	139.264
STM1E	155.520	
IEEE 802.3	10BASE-T	10

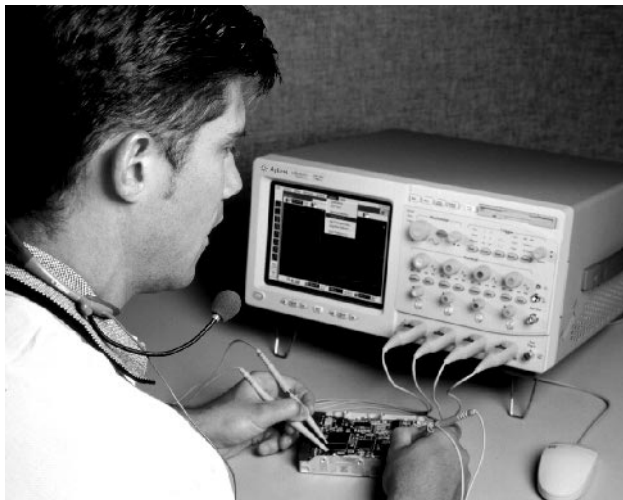

Use Infiniium’s award-winning VoiceControl for hands-free control of the scope’s front panel.

### Option 200—VoiceControl Option

Infiniium can now be controlled with VoiceControl (Option 200). Using a microphone, which is included, users can now control front panel functions with the use of voice commands (English only) allowing hands-free operation of the scope. This is an extremely valuable option for users who need both hands to probe fine-pitch, surface mount parts. VoiceControl is both speaker and gender independent and does not require training as most voice recognition systems.

### Easy Probing

A full line of compatible passive, active, and differential probes are available for Infiniium. These probes contain the AutoProbe interface, which completely configures Infiniium for the proper attenuation ratio, input impedance, probe power, and offset range if needed. See the Infiniium Probes and Accessories datasheet for more information, p/n 5968-7141.

## General Specifications Chart for Infiniium Oscilloscopes

	54810A	54815A	54820A	54825A	54835A	54845A
<b>Bandwidth</b>	500 MHz	500 MHz	500 MHz	500 MHz	1 GHz	1.5 GHz
<b>Channels</b>	2	4	2	4	4	4
<b>Sample Rate</b>	1 GSa/s	1 GSa/s	2 GSa/s	2 GSa/s	2 ch. mode: 4 GSa/s 4 ch. mode: 2 GSa/s	2 ch. mode: 8 GSa/s 4 ch. mode: 4 GSa/s
<b>Memory/Channel</b>	32K				2 ch. mode: 64K 4 ch. mode: 32K	2 ch. mode: 64K 4 ch. mode: 32K
<b>Vertical Resolution</b>	8 bits; 12 bits or greater with averaging					
<b>Sensitivity<sup>1</sup></b>	1 M $\Omega$ : 1 mV/div to 5 V/div 50 $\Omega$ : 1 mV/div to 5 V/div			1 M $\Omega$ : 2 mV/div to 2 V/div 50 $\Omega$ : 2 mV/div to 1 V/div		
<b>Input Impedance</b>	1 M $\Omega$ $\pm$ 1% ( $\approx$ 8pF) or 50 $\Omega$ $\pm$ 1%				1 M $\Omega$ $\pm$ 1% ( $\approx$ 12pF) or 50 $\Omega$ $\pm$ 1.5%	
<b>Timebase Range</b>	500 ps/div to 20 s/div				100 ps/div to 20 s/div	
<b>Trigger Enhancements</b>	Edge, glitch, pattern, state, delay by time, delay by events, video, line, violation (runt, setup/hold time, pulse width, transition)					
<b>Measurements</b>	27 automatic waveform parameter measurements with statistics					
<b>Math Functions</b>	4 functions, F1–F4. Select from add, subtract, multiply, divide invert, magnify, Vs, min, max, integrate, differentiate, FFT magnitude. Any of the waveform math functions (e.g., FFT) can be averaged.					
<b>Other Analysis Functions</b>	Histograms (vertical/horizontal), automask capability, eye diagram measurements, variable persistence, dual density, infinite persistence, color grade persistence waveforms.					
<b>Storage</b>	Instrument setups, waveforms, and screen images can be stored to either the 3.2 GB hard disk or the LS-120 120 MB Super Disk floppy drive (reads/writes to standard 3.5" floppy disks). Four nonvolatile waveform memories also available.					
<b>Display</b>	Large 8.4-inch color active matrix LCD display.					
<b>Display Annotation</b>	Up to 12 labels, with up to 100 characters each, can be inserted into the waveform display area.					
<b>Waveform Update Rate</b>	>2,100 waveforms/sec					
<b>Printer Support</b>	Full support of HP DeskJet and LaserJet printers.					
<b>I/O</b>	10/100 Mbps LAN, GPIB, RS-232, and Centronics					
<b>Power</b>	Voltage: 100-240 VAC, $\pm$ 10%, Cat II, 47 to 440 Hz; max. power dissipation: 390 W					
<b>Weight</b>	10.6 kg (23.4 lb)				12.0 kg (26.5 lb)	
<b>Size</b>	216 mm H x 437 mm W x 440 mm D (8.5 in x 17.2 in x 17.3 in)					
<b>Warranty</b>	3 years					

<sup>1</sup>54810A/15A/20A/25A: Magnification is used below 7 mV/div range. Below 7 mV/div, full scale is defined as 56 mV. 54845A: Magnification is used below 10 mV/div range and between major attenuation settings. Full scale is defined as the major attenuator setting above an intermediate setting. (Major settings 50  $\Omega$ : 10 mV, 20 mV, 50 mV, 100 mV, 200 mV, 500 mV, 1V, 1 M $\Omega$ : all the above plus 2V.)

54810A  
54815A  
54820A  
54825A  
54835A  
54845A

4

### E2633A Infiniium Performance Upgrade— Hardware and Software Upgrading by Agilent

For a nominal charge, Agilent will upgrade the hardware and software in your Infiniium oscilloscope. The type of upgrade you need is determined by the serial number of your scope. Some upgrade items include:

- Updating the scope processor and installing additional RAM and a LAN card
- Installing a new LS-120 SuperDisk 120 MB floppy drive (reads and writes to 3.5" floppies)
- Installing the latest version of the Infiniium scope application software
- Performing other product adjustments and changes as needed, and calibrating the scope.

You'll end up with a better, faster Infiniium that makes it even easier to get your job done.

### Ordering Information

**54810A** 500 MHz (2 ch., 1 GSa/s) oscilloscope  
**54815A** 500 MHz (4 ch., 1 GSa/s) oscilloscope  
**54820A** 500 MHz (2 ch., 2 GSa/s) oscilloscope  
**54825A** 500 MHz (4 ch., 2 GSa/s) oscilloscope  
**54835A** 1 GHz (4ch., 2 GSa/s or 2 ch., 4 GSa/s) oscilloscope  
**54845A** 1.5 GHz (4 ch., 4 GSa/s or 2 ch., 8 GSa/s) oscilloscope

#### All of the above models include:

2 1160A 10:1 10M  $\Omega$  passive probes (54810A, 54820A)  
 4 1160A 10:1 10M  $\Omega$  passive probes (54815A, 54825A)  
 4 1161A 10:1 10M  $\Omega$  passive probes (54835A, 54845A)  
 Mouse, Infiniium Mouse Pad, keyboard, protective front cover  
 1 User's Quick Start Guide, 1 Service Guide, 1 Programmer's Guide, 1 Programmer's Quick Reference Guide, Information System in English, French, German, Japanese, Korean, Chinese  
 1 Accessory Pouch, 1 US power cord, three-year warranty

#### Options

- Opt 001** Provides additional standard probes  
 2 1160A probes for the 54810A/815A/820A/825A  
 2 1161A probes for the 54835A/845A
- Opt 002** Add 1 1162A 1:1 passive probe
- Opt 003** Add 1 1163A 10:1 500  $\Omega$ , low C passive probe
- Opt 006** Add 1 1152A 2.5 GHz, 0.6 pF active probe (54835A/845A)
- Opt 008** Add 1 1153A 200 MHz differential probe
- Opt 009** Add 1 1154A 500 MHz differential probe
- Opt 010** Add 1 1159A 1 GHz differential probe
- Opt 015** Extended (runt) triggering (standard on the 54835A and 845A)
- Opt 090** Deletes standard probes  
 2 1160A probes for the 54810A/820A  
 4 1160A probes for the 54815A/825A  
 4 1161A probes for the 54835A/845A
- Opt 100** Communication Mask Test Kit (E2625A)
- Opt 200** Voice Control for Infiniium oscilloscopes
- Opt 1BP** Mil Std 45662A and ANSI/NCSS Z-540 calibration with test data
- Opt 1CM** Add 1 rackmount kit (E2609A)—includes TouchPad
- Opt UL5** Add 1 TouchPad pointing device (E2612A)
- Opt UL6** Add 1 Clip-on track ball pointing device (E2611A)
- Opt W32** Three-year return for calibration
- Opt W34** Three-year return for standards compliant calibration
- Opt W50** Five-year, customer return, repair coverage (additional 2 years)
- Opt W52** Five-year return for calibration service
- Opt W54** Five-year return for standard-compliant calibration

**E2617A** Infiniium Oscilloscope Transit Case  
 Heavy-duty hard cover carrying case is constructed from rugged A.B.S. and has a rubber grip, steel handles, and steel latches. Moving the instrument is easy with the pull out handle and wheels. The case can be padlocked.

**E2633A** Infiniium Oscilloscope Performance Upgrade  
 The upgrade price is determined by the serial number prefix (the 4 numbers that follow the letters "U.S.") in the serial number of your Infiniium. You can find your scope's serial number by using your mouse to click on Help/About Infiniium or by looking on the back of your scope.

**Opt 001** Serial number prefixes beginning with U.S. 3805

This option includes: All Opt 003 features, upgrading processor from 133 MHz to 300 MHz, increasing RAM to 64MB, adding a LAN card (if not already installed)

**Opt 002** Serial number prefixes from U.S. 3805 to U.S. 3844

This option includes: All Opt 003 features, upgrading processor from 200 MHz to 300 MHz

**Opt 003** Serial number prefixes beginning with U.S. 3845

This option includes: Upgrading your scope to Windows 98 and the latest version of Infiniium software, replacing the 1.44MB floppy drive with LS-120 SuperDisk 120MB floppy, other hardware adjustments and updates, scope calibration

**Opt 004** Infiniium VoiceControl upgrade

This option includes upgrading to the latest version of the Infiniium software, adding VoiceControl software, adding VoiceControl hardware (sound card, collar-mounted microphone), and installation. This option must be ordered along with one of the above 3 options (001–003).

Once your order has been received, Agilent will provide instructions on how to return your Infiniium to the nearest Agilent service center for the upgrade. The scope will be upgraded and returned to you within 3 weeks after receipt by Agilent.



E2611A Clip-on Trackball

If you don't have the bench space for a standard mouse, a clip-on trackball is available for Infiniium oscilloscopes. The trackball clips into slots on the instrument. The driver for the clip-on trackball is pre-installed in the Infiniium oscilloscope.

For more information on Infiniium oscilloscopes, please visit our web site at: [www.agilent.com/find/infiniium1](http://www.agilent.com/find/infiniium1)



- Bandwidth to 50 GHz
- 100 Mb/s to 12.5 Gb/s and beyond
- Built-in compliance tests
- Integrated optical and electrical channels
- Familiar Windows-98 user interface
- Compatible with 83480A series modules

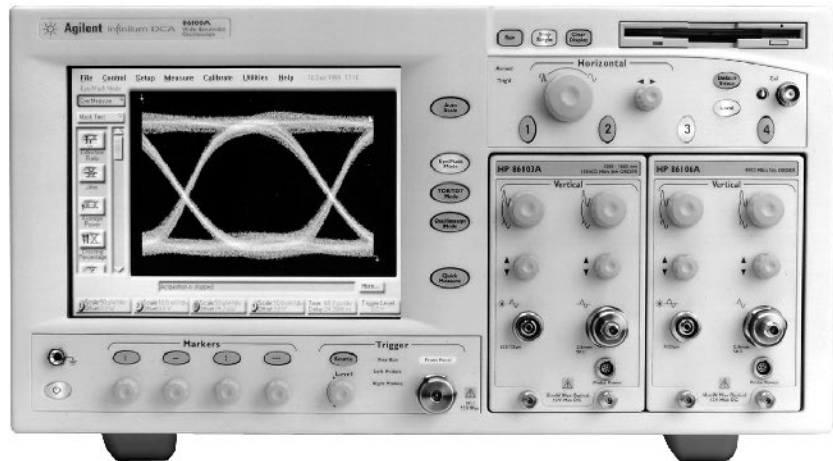

86100A

86100A

## 86100A Infiniium DCA – Wide-Bandwidth Oscilloscope



Agilent 86100A Infiniium DCA was designed to make accurate waveform measurements fast and simple. The Infiniium DCA can be viewed as three instruments in one. It's a general purpose equivalent time sampling oscilloscope, a digital communication analyzer, and time-domain reflectometer. Just select the instrument mode and start making measurements.

### Familiar Windows-98 User Interface

The Infiniium DCA has an intuitive graphical user interface, so you won't have to spend a lot of time learning or relearning the instrument. Pull-down menus give you easy access to advanced features and icons provide quick access to an extensive set of common tests and measurements. Use the high-performance touchscreen or a mouse to navigate the instrument interface.

The simple, uncluttered front panel has the feel of an analog scope with dedicated scale and position knobs for each vertical channel. Trigger LEDs show you trigger status at a glance. To speed up measurements, you can configure the Quick Measure key for instant access to any four measurements in each instrument mode.

### Measurement Speed

Measurement speed has been increased with both fast hardware and a friendlier user interface. In the lab, you can't afford to waste time figuring out how to make a measurement, the Infiniium DCA eliminates the relearning curve. In manufacturing, it is a battle to continually reduce cost per test. Infiniium DCA has fast PC-based processors, resulting in high measurement throughput and reduced test time.

### Smaller Modular Platform

The Infiniium DCA has a large and growing family of plug-in modules designed for a broad range of data rates for optical and electrical waveforms. The Infiniium DCA can hold up to 2 modules for a total of 4 measurement channels. To protect your investment in Agilent's previous platform, all modules from the 83480A and 54750A family are forward compatible with the Infiniium DCA.

The Infiniium DCA is smaller and much lighter than the previous generation wide-bandwidth oscilloscopes. It also uses less than half the power the 83480A and 54750A used.

### GPIB Code Compatible

The remote programming command set for the Infiniium DCA has been designed to be directly compatible with software written to control the 83480A and 54750A. (Due to improvements and updates in performance, a small set of remote commands may need minor modifications to control the Infiniium DCA.)

### Compliance Tests

Accurate eye-diagram analysis is essential for characterizing the quality of transmitters used from 100 Mb/s to beyond 12.5 Gb/s. The Agilent Infiniium DCA was designed specifically for the complex task of analyzing digital communications waveforms. Compliance mask and parametric testing no longer require a complicated sequence of setups and configurations. The important measurements you need are right at your fingertips, including:

- Industry standard mask testing with built-in margin analysis
- Extinction ratio measurements with improved accuracy and repeatability
- Automatic eye measurements: crossing %, eye height and width, '1' and '0' levels, jitter, rise or fall times and more.

### Time Domain Reflectometer (TDR)

TDR measurements are focused on high-speed applications where it is necessary to optimize electrical system components, such as microstrip lines, PC board traces, SMA edge launchers and coaxial cables where imperfections cause signal distortion and reflections. Signal integrity is a critical requirement in high-speed digital signal transmission.

### Built-in Information System

Infiniium DCA's built-in information system puts measurement assistance at your fingertips. You'll no longer have to look for the manual when you need help setting up the DCA or making complex measurements. A set-up guide gives you step-by-step instructions for many measurements and procedures. Links on the measurement screen take you directly to the information you need in the on-line manual.

### Internal Hard and Floppy Disk Drives

Use the internal 3 GB hard drive or the 3.5 inch, 120 MB SuperDisk floppy disk drive to store instrument setups, waveforms, or screen images. Screen images can be stored in many standard industry file formats. LAN access is supported for network access and file sharing.

### Gated Triggering

Rear panel trigger gating port allows easy external control of data acquisition for circulating loop or burst-data experiments. Use TTL-compatible signals to control when the instrument does and does not acquire data.

### Stimulus Response Testing Using the 86130A BitAlyzer

Error performance analysis represents an essential part of digital transmission test. The Infiniium DCA and 86130A BitAlyzer error performance analyzer come together to create a powerful test solution where two instruments together can perform measurements that would not be possible. For more information on the 86130A BitAlyzer see page 406.

4

86100A Series



86100A with plug-in modules

## Modules for the 86100A Infiniium DCA

The Infiniium DCA has a large family of plug-in modules designed for a broad range of data rates for optical and electrical waveforms. The Infiniium DCA can hold up to 2 modules for a total of 4 measurement channels. All optical measurement plug-in modules also have a dual bandwidth electrical channel.

The Agilent 86101A and 86103A modules incorporate an optical channel with over 2.85 GHz of bandwidth and a 20 GHz electrical channel. The electrical channel has both a 20 GHz mode for better waveform fidelity, and a 12.4 GHz mode for optimum noise performance. The calibrated, integrated optical channel has over 2.85 GHz bandwidth for easy, precise single-mode and multimode optical measurements. The 86101A and 86103A utilize switchable reference filters for transceiver compliance testing at OC-3, OC-12, OC-48, Fibre Channel, 1063, and Gigabit Ethernet 1250 data rates. The 86101A operates over the 750 nm to 860 nm wavelength range, and the 86103A operates over the 980 nm to 1625 nm wavelength range.

The 86105A module incorporates a single-mode optical channel with over 20 GHz of bandwidth and a 20 GHz electrical channel. The electrical channel has both a 20 GHz mode for better waveform fidelity, and a 12.4 GHz mode for optimum noise performance. The 86105A utilizes switchable reference filters for transceiver compliance testing at OC-3, OC-12, OC-48, and OC-192 data rates.

The 86106A module incorporates a 10 Gb/s optical reference receiver and a 40 GHz electrical channel. The electrical channel also has a reduced bandwidth setting of 18 GHz for improved noise performance. It includes a reference receiver path for 10 Gb/s transmitter test that has been designed to meet OC-192/STM-64 standards.

The 86109A module incorporates a 30 GHz optical measurement channel and a 40 GHz electrical channel. The electrical channel has a reduced bandwidth setting of 18 GHz for improved noise performance. The optical channel frequency response is designed to minimize distortion of the displayed optical pulse and does not include any provision for switching a SDH/SONET filter into the channel.

The 86112A electrical module provides two measurement channels with user selectable bandwidths. The 12.4 GHz bandwidth mode provides better noise performance for accurate measurement of small signals. The 20 GHz bandwidth mode provides high fidelity display and measurement of very high speed waveforms.

The 83484A electrical module provides two measurement channels with user selectable bandwidths. The 26.5 GHz bandwidth mode provides better noise performance for accurate measurement of small signals, and 50 GHz bandwidth mode provides higher fidelity for very high speed waveforms.

The 54753A is a two channel electrical plug-in with a TDR step generator built into channel one. The TDR channel has 18 GHz of bandwidth while the second channel has 20 GHz of bandwidth. The 54754A is a differential TDR with two channels, each of which have a built-in step generator and 18 GHz of bandwidth.

The 8349XA series of clock recovery modules provide a recovered clock and recovered data output, and the ability to trigger on data for slower rates. The 83491A accepts electrical inputs, the 83492A accepts multimode fiber inputs, and the 83493A accepts single mode fiber inputs. The new 83494A clock recovery module provides clock recovery for both 2.488 and 9.953Gb/s testing. All four clock recovery modules support standard telecom and/or enterprise data rates.

Plug-in Module	Electrical Channels		Optical Channel					
	Number	Bandwidth GHz	Fiber Input	Wavelength	Unfiltered Bandwidth GHz (typical)	Filters	Filter Rates Mb/s	Mask Test Sensitivity (Characteristic)
83484A	2	26.5/50						
86101A (83487A)	1	12/20	62.5/125 um	750–860 nm	2.85 (>3.0)	2 or 3	155, 622, 1063, 1250, 1563, 2125, 2488	(–17 dBm)
86103A (83486A)	1	12/20	62.5/125 um	980–1625 nm	2.85 (>3.0)	2 or 3	155, 622, 1063, 1250, 2125, 2488	(–20 dBm)
86105A (83485A)	1	12/20	9/125 um	980–1625 nm	20	1, 2 or 3	155, 622, 2488, 3125, 9953	(–10 dBm)
86106A (83485B)	1	18/40	9/125 um	980–1625 nm		1	9953	(–8 dBm)
86109A (83482A)	1	18 & 40	9/125 um	980–1625 nm	30			
86112A (83483A)	2	12 & 20						
54753A	1 TDR/ Elec. & 1 Elec.	12/18 and 12/20						
54754A	2 TDR/ Elec.	12/18						
Clock Recovery	Input	Operating Input Power Level for Clock Recovery	Insertion Loss	Data Rates for Clock recovery	Tracking/ Acquisition Range	Module Contributed Jitter (Characteristic)		
83491A	50 Ohm Electrical	–10 to +3 dBm	DC-2500 MHz: 7 dB 4500 MHz: 10 dB	155, 622, 1060, 1250, 2125, 2488, 2500 Mb/s	±0.1%	<0.0125 UI RMS (<0.01 UI RMS)		
83492A	62.5/125 um	750–860 nm: –10 to +3 dBm 1000–1600 nm: –13 to +3 dBm	≤5.0 dBm max	155, 622, 1060, 1250, 2125, 2488, 2500 Mb/s	±0.1%	<0.0125 UI RMS (<0.01 UI RMS)		
83493A	9/125 um	1000–1600 nm: –20 to +3 dBm	≤1.5 dBm max	155, 622, 1250, 2488, 2500 Mb/s	±0.1%	<0.0125 UI RMS (<0.01 UI RMS)		
82494A	9/125 um	1000–1600 nm: –10 to +3 dBm	≤1.5 dBm max	2488 and 9953 Mb/s				



54118A 18 GHz Trigger



N1020A TDR Probe



PicoSecond ATE Static Protection Unit



54008A 20 GHz Delay Line



54007A RF Accessory Kit



N1025A 1 GHz Differential Probe

### Static Protection Unit from picosecond ATE Inc.

The picosecond ATE Inc. Static Protection Unit model 1202 offers static damage protection for TDR measurements. A foot switch or TTL signal allows connection of the device under test after static charge is removed. Risettime is <40 ps. In North America contact Stu McNaughton at picosecond ATE Inc. (503) 641-3295; [www.picosecondate.com](http://www.picosecondate.com).

### 54118A, 500 MHz to 18 GHz Trigger

#### Simple, Stable Triggering at Microwave Frequencies

For applications requiring more than 2.5 GHz trigger bandwidth, use the 54118A 18 GHz trigger. The 54118A gives your 54750 or 81600A series oscilloscope true event triggering from 500 MHz to 18 GHz, with less than 1.7 ps of rms jitter at 18 GHz. This powerful and versatile accessory extends the oscilloscope's measurement capabilities to applications in lightwave communications, pulsed RF, gigabit logic, pseudo-random bit-stream eye patterns, and other microwave signals.

### N1020A TDR Probe

The N1020A TDR Probe is a useful accessory when making time domain reflectometry measurements on printed circuit boards. If no convenient method of connection is available, such as an SMA launch, then probing is the only viable solution.

When used in conjunction with the Agilent TDR Oscilloscope Family (81600A or 54750), it provides X, Y and Z positioning in one fluid motion. Its unique 3-D joystick has a 3:1 motion reduction with a fully articulating arm which allows simple positioning in anything from card cages to microstrip-line.

### N1025A 1 GHz Active Differential Probe

NEW

One full gigahertz of bandwidth, excellent common-mode rejection ratio (CMRR) and low noise make the N1025A ideal for today's high-speed data communications applications. The N1025A probe provides a range of sensitivities from x1 gain to  $\div 10$  and  $\div 20$  attenuation (with plug-on attenuators) for diverse signals. At full gain, the noise is less than 35 nV/root Hz, allowing direct measurement of low-amplitude and high-bandwidth signals, such as LVDS.

### Launching and Probing Solutions from Inter-Continental Microwave (ICM)

ICM offers both fixed- and variable-spacing 50- $\Omega$  TDR/TDT probe assemblies for launching a TDR pulse into transmission systems under test, such as in a PC board trace. These probes can be hand-held or placed in a manipulator. ICM offers an automated flying probe system with a robotic TDR probe arm. In North America contact Werner Schuerch at ICM, 1515 Wyatt Dr., Santa Clara, CA 95054-1524; (408)727-1596; [www.icmicrowave.com](http://www.icmicrowave.com).

### 54008A 22 ns Delay Line

#### Viewing the Trigger Signal

The 54008A delay line provides 22 ns of delay with a useable frequency response of 20 GHz. By adding this accessory to your 86100A or 54750 oscilloscope system, you will be able to view the trigger event. The 54008A has enough delay to view the trigger event with the 54118A trigger installed in the trigger path also.

### 54007A Accessory Kit

#### Low-Loss Measurements for 86100A and 54750A Oscilloscope Systems

The 54007A accessory kit provides an assortment of parts with 3.5-mm connectors. This kit is highly recommended for low-loss reflection and transmission measurements. It also includes semi-rigid coax, formed for use with the 11667B power splitter.

### PicoSecond Pulse Labs 4015C

#### 15-ps, 9 V External TDR or TDT Source

The PicoSecond Pulse Labs model 4015C pulse generator extends the TDR/TDT performance of the 86100A or 54750 series oscilloscopes. The pulse generator produces a 15-ps fall time with an amplitude of 9 V, which can be triggered by any 86100A or 54750 series TDR step generator. The 1167C power splitter is not included. In North America contact Dr. Jim Andrews at PSPL, P.O. Box 44, Boulder, CO 80306; (303)443-1249; [www.picosecond.com](http://www.picosecond.com).

### 83440 Series Unamplified Lightwave Converters and 11982A Amplified Lightwave Converter

These products are wide-range optical-to-electrical converters for characterizing SONET/SDH optical waveforms. See page 477 for more information.

54007A  
54008A  
54118A  
N1020A  
N1025A

4

# Oscilloscope Probes & Accessories

## Choosing the Right Probe, High Impedance Passive Probes

### Oscilloscope/Probe Compatibility

Oscilloscope	General Purpose Passive Probes										
	10:1	100:1	1000:1	1:1	Low Mass 10:1	Low Mass 20:1	Low Z	50 Ohm	Active	Differential	Current
Infiniium Oscilloscopes 54810/15/20/25A	1160A 1164A	10440B <sup>2</sup> , 10076A	N2771A	1162A	1170A	1172A	1163A	10437B	1152A, 1155A,	1153A <sup>3</sup> , 1154A, 1159A	1146A, N2774A
54835A, 54845A, 54846A Infiniium Oscilloscopes	1161A	10440B <sup>2</sup> , 10076A	N2771A	1162A	1171A	1173A	1163A 10020A	10437B 10020A	1152A <sup>2</sup> , 1155A <sup>2</sup> ,	1153A <sup>3</sup> , 1154A, 1159A	1146A, N2774A
54751/52A/B	–	–	–	–	–	–	54006A	–	54701A <sup>2,4</sup>	1141A <sup>2,3</sup>	–
54711/12/21/22A	–	–	–	–	–	–	54006A	–	54701A <sup>4</sup>	1141A <sup>2,3</sup>	–
54714/15A/13B	10441B	10440B, 10076A	N2771A	10439B	1170A <sup>1</sup>	1172A <sup>1</sup>	10442B	10437B	1144A <sup>3</sup> , 1145A <sup>3</sup> , 54701A <sup>4</sup>	1141A <sup>2,3</sup>	–
54645A/D	10074C	10440B, 10076A	N2771A	10070C	1171A <sup>1</sup>	1173A <sup>1</sup>	–	–	1144A <sup>3</sup> , 1145A <sup>3</sup> w 50 Ohm term	1141A <sup>3</sup> w 50 Ohm term N2772A	1146A, N2774A
54621A/D 54622A/D/24A	10074C	10440B, 10076A	N2771A	10070C 10439B	1171A	1173A	–	–	–	1141A <sup>3</sup> w 50 Ohm term N2772A	1146A, N2774A
54615/16B	10073B	10440B, 10076A	N2771A	10070C 10439B	1170A <sup>1</sup>	1172A <sup>1</sup>	1163A <sup>1</sup> 10442B	10437B	1144A, 1145A	1141A <sup>3</sup> N2772A	1146A, N2774A
54610A/B	10073B	10440B, 10076A	N2771A	10070C 10439B	1170A <sup>1</sup>	1172A <sup>1</sup>	1163A <sup>1</sup> 10442B	10437B	1144A <sup>3</sup> , 1145A <sup>3</sup>	1141A <sup>2,3</sup> N2772A	1146A, N2774A
54600/01/02/03A/B	10074C	10440B, 10076A	N2771A	10070C 10439B	1171A <sup>1</sup>	1173A <sup>1</sup>	–	–	1144A <sup>3</sup> , 1145A <sup>3</sup> w 50 Ohm term	1141A <sup>3</sup> w 50 Ohm term N2772A	1146A, N2774A
54520/22/40/42A/C	10441B	10440B <sup>2</sup> , 10076A	N2771A	10439B	1170A <sup>1</sup>	1172A <sup>1</sup>	10442B	10437B	1144A, 1145A	1141A	1146A, N2774A
54502/03/04/10A/05/06/10/12B	10441B	10440B <sup>2</sup> , 10076A	N2771A	10439B	1170A <sup>1</sup>	1172A <sup>1</sup>	10442B	10437B	1144A <sup>3</sup> , 1145A <sup>3</sup>	1141A <sup>3</sup>	1146A, N2774A
54501A	10433B	10440B 10076A	N2771A	10439B	–	–	–	–	1144A <sup>3</sup> , 1145A <sup>3</sup> w 50 Ohm term	1141A <sup>3</sup> w 50 Ohm term	1146A, N2774A
54201A/D	10433B	10440B 10076A	N2771A	10439B	1170A <sup>1</sup>	1172A <sup>1</sup>	10442B	10437B	–	1141A <sup>3</sup>	1146A, N2774A
54200A/D	10433B	10440B 10076A	N2771A	10439B	1170A <sup>1</sup>	1172A <sup>1</sup>	–	–	–	1141A <sup>3</sup> w 50 Ohm term	1146A, N2774A
54121/22/23/24T	–	–	–	–	–	–	54006A	10020A	54701A <sup>2,4</sup>	1141A <sup>3</sup>	–
54111/112D	10441B	10440B 10076A	N2771A	10439B	1170A <sup>1</sup>	1172A <sup>1</sup>	10442B	10437B	1144A <sup>3</sup> , 1145A <sup>3</sup>	1141A <sup>3</sup>	1146A, N2774A
1980, 1950AA/B	10433B	10440B 10076A	N2771A	10439B	–	–	10442B	10437B	–	–	1146A, N2774A
1740/41/42/43/44/45/46A	10436B	10076A	N2771A	10439B	–	–	10442B	10437B	1144A <sup>3</sup> , 1145A <sup>3</sup>	1141A <sup>3</sup>	1146A, N2774A
1715/22/25/26/27	10433B	10440B 10076A	N2771A	10439B	–	–	10442B	10437B	1144A <sup>3</sup> , 1145A <sup>3</sup>	1141A <sup>3</sup>	1146A, N2774A

<sup>1</sup>Must remove pogo pin and configure scope for probe manually  
<sup>2</sup>Not commensurate with oscilloscope bandwidth

<sup>3</sup>Requires the 1142A probe power supply  
<sup>4</sup>Requires the 1143A probe offset and power module

### 10070 Passive Divider Probe Family

The 10070 family of rugged, general purpose probes are designed to operate with the 54600 family of oscilloscopes. This family provides a range of high-quality probing solutions at very reasonable prices.

These reliable probes come with one retractable hook tip, eight color identification tags, one ground bayonet, one IC Tip, one adjustment tool, and one ground lead.

See page 128 for compatible SMT probing kit.

10070 Passive Divider Probe Series



Model	Length	Division ratio	Circuit loading (1 MΩ scope input)	Typical scope bandwidth	Compensates oscilloscope input
10070C	1.5 m	1:1	1 MΩ; 70 pF	20 MHz	High Impedance
10073B	1.5 m	10:1	2.2 MΩ; 12 pF	500 MHz	1 MΩ; 6 to 15 pF
10074C <sup>3</sup>	1.5 m	10:1	10 MΩ; 15 pF	150 MHz	1 MΩ; 9 to 17 pF
10076A	1.8 m	100:1	66.7 MΩ; 3 pF	250 MHz	1 MΩ; 7 to 20 pF

<sup>3</sup> Probe ID pin

### Other 10070 Series Probe Accessories

Accessory	p/n
Probe tip to BNC (m) adapter	5081-7705
Replacement parts accessory kit	5081-7690
SMT probe accessory kit	10072A
0.5 mm IC probing kit	10075A
Retractable hook tip, qty 2	N2769A
Alligator ground lead, qty 2	N2770A

### Other Accessories

Accessory	p/n
BNC 50 Ω feedthrough	10100C
BNC 75 Ω feedthrough	11094B
BNC AC blocking capacitor	10240B



### 10400B Passive Divider Probe Family

The 10400B probe family are reliable general-purpose high performance passive probes that replace the 10400A family of probes. These probes include a no-slip browser. The crown point of the browser digs in to solder and won't slip while the pogo pin allows small hand movements without losing contact.

The 10400B family of probes also comes complete with a range of accessories. For grounding, there's an alligator ground lead for general-purpose probing, 4 spring grounds for high frequency measurements and a socketed ground lead. The accessories also include 2 IC clips for probing 50 mil SMDs and a dual-lead adapter so that both the probe tip and ground can easily be connected to surface mount devices.

The miniature probe has a narrow, sharp tip that is good for probing SMDs. The handle of the probe can be unscrewed and pulled back on the cable to reduce the probe's mass and size. This makes attaching to fine pitch ICs and small devices easier. For connection to fine pitch ICs order the Wedge probe adapter or the 0.5 mm IC clips.

The 10400 family of probes are built and tested for high reliability. The cable has a Kevlar strengthener for added pull strength and the general purpose retractable hook tip is made from durable music wire. The probe tips are replaceable.

See page 128 for compatible SMT probing solutions.

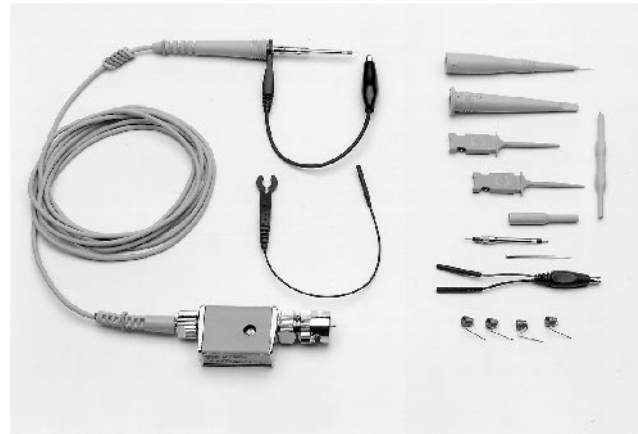

10400B Passive Divider Probe Series

10400 Family

4

Model	Length	Division ratio	Circuit loading	Typical scope bandwidth	Compensates oscilloscope input
10437B	2 m	1:1	50 Ohm	—	50 Ohm
10439B <sup>1</sup>	1.5 m	1:1	65 pF	—	High Z
10433B	2 m	10:1	10 MOhm; 10 pF	300 MHz	1 MOhm; 10 – 16 pF
10436B	2 m	10:1	10 MOhm; 11 pF	100 MHz	1 MOhm; 18 – 22 pF
10441B	1.8 m	10:1	10 MOhm; 9 pF	500 MHz	1 M; 6 – 9 pF
10442B	2 m	10:1	500 Ohm; 1.2 pF	1 GHz	50 Ohm
10440B	2 m	100:1	10M; 2.5 pF	300 MHz	1 M; 6 – 14 pF

<sup>1</sup>This probe can be used with many oscilloscopes, but because of the relatively high capacitance, there will be bandwidth degradation

### 10400B Family Replacement Parts

p/n	Description	Qty
5063-2115	Browser	1
5063-2120	Socketed ground lead	1
5063-2135	General-purpose retractable hook tip	2
5063-2140	Alligator ground lead	2
5063-2147	Dual lead adapter	1
5063-2149	SMD clips	5
01160-68701	Accessory Kit: spring grounds browser pogo pins barrel insulators screwdriver	4 4 4 1
5063-2167	10433B probe tip	5
5063-2168	10436B probe tip	5
5063-2138	10437B probe tip	5
5063-2138	10439B probe tip	5
5063-2171	10440B probe tip	5
5063-2172	10441B probe tip	5
5063-2139	10442B probe tip	5

### Fine Pitch IC Probing Accessories

p/n	Description	Qty
E2613B	Wedge probe adapter, 0.5 mm, 3-signal	2
E2614A	Wedge probe adapter, 0.5 mm, 8-signal	1
E2615B	Wedge probe adapter, 0.65 mm, 3-signal	2
E2616A	Wedge probe adapter, 0.65 mm, 8-signal	1
E2643A	Wedge probe adapter, 0.5 mm, 16-signal	1
E2644A	Wedge probe adapter, 0.65 mm, 16-signal	1
10467-68701	0.5mm IC clips for surface SMT parts with lead spacings of 0.5 mm (.020 in) to 0.8mm (0.32 in)	4

### PC Board Mini-Probe Sockets

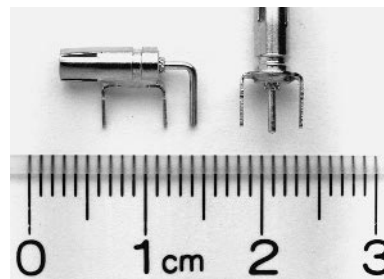

The PC board mini-probe sockets are ideal for reliable, stable, and convenient connection between the probe tip and the circuit under test. These probe sockets are designed for use with the 1160A-family and 10400B-family of passive probes.

### Ordering Information

- N2765A Horizontal Mini-Probe Socket, qty 5
- N2766A Horizontal Mini-Probe Socket, qty 25
- N2767A Vertical Mini-Probe Socket, qty 5
- N2768A Vertical Mini-Probe Socket, qty 25

1160A

### 1160A Family Miniature Passive Probes

The 1160 family of miniature probes are reliable general-purpose probes for use with Infiniium Oscilloscopes (54800 series). The 1160 family probes include a no-slip browser with a crown point that digs in to solder, and won't slip. The pogo pin allows hand movement without losing contact.

A variety of grounding accessories are included. An alligator ground lead for general-purpose probing, 4 spring grounds for high frequency measurements, a socketed ground lead and 2 SMD IC clips for probing 50 mil SMD. Also included is a dual lead adapter so that both the probe tip and ground can be connected to SMD devices. For connection to 0.5 mm–0.8 mm devices, order the 10467-68701 0.5 mm IC clips.

The 1160 family probes are built and tested for high reliability. The cable has a kevlar strengthener for added pull strength. The general-purpose retractable hook tip has a durable music wire hook. And probe tips are replaceable.

The miniature probe has a narrow, sharp tip that is good for probing SMD. To fully miniaturize the probe, unscrew the handle and pull it back on the cable. The 1160 family probes are compatible with the AutoProbe Interface, which completely configures the Infiniium Oscilloscope for the probe.

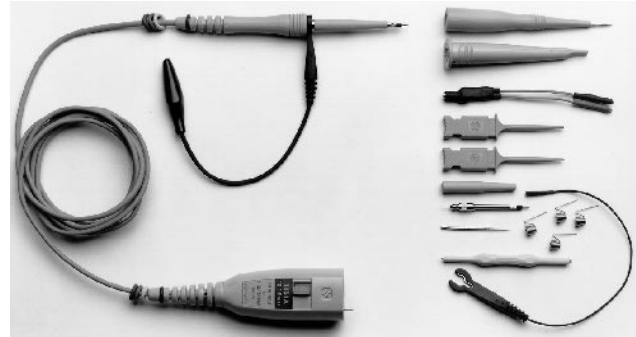

1160A Miniature Passive Probe Series

4

Model	Type of probe	Length	Division ratio	Circuit loading	System bandwidth (scope and probe)	Oscilloscope input
1160A	High Impedance, Passive	1.5 m	10:1	10 MOhm, 9pF	500 MHz <sup>1</sup>	1 MOhm, 6–9 pF
1161A	High Impedance, Passive	1.5 m	10:1	10 MOhm, 10 pF	500 MHz <sup>2</sup>	1 MOhm, 12–14 pF
1162A	High Impedance, Passive	1.5 m	1:1	1 MOhm, 50 pF +scope input	25 MHz <sup>3</sup>	1 MOhm
1163A	500 Ohm Resistive Divider	1.5 m	10:1	500 Ohm, 1.5 pF	1.5 GHz <sup>2</sup>	50 Ohm
1164A	High Impedance, Passive	2.0 m	10:1	10 MOhm, 10pF	500 Mhz <sup>1</sup>	1 MOhm, 6–9 pF

<sup>1</sup> System bandwidth with 54810A/15A/20A/25A

<sup>2</sup> System bandwidth with 54845A

<sup>3</sup> System bandwidth with all Infiniium scopes

### 1160 Family Replacement Parts

p/n	Description	Qty
5063-2115	Browser	1
5063-2120	Socketed ground lead	1
5063-2135	General-purpose retractable hook tip	2
5063-2140	Alligator ground lead	2
5063-2147	Dual lead adapter	1
5063-2149	SMD IC clips	5
01160-68701	Accessory kit: Spring grounds Browser pogo pins Barrel insulators Screwdriver	4 4 4 1
5063-2136	1160A probe tip	5
5063-2137	1161A probe tip	5
5063-2138	1162A probe tip	5
5063-2139	1163A probe tip	5

### Fine Pitch IC Probing Accessories

p/n	Description	Qty
E2613B	Wedge probe adapter, 0.5 mm, 3-signal	2
E2614A	Wedge probe adapter, 0.5 mm, 8-signal	1
E2615B	Wedge probe adapter, 0.65 mm, 3-signal	2
E2616A	Wedge probe adapter, 0.65 mm, 8-signal	1
E2643A	Wedge probe adapter, 0.5 mm, 16-signal	1
E2644A	Wedge probe adapter, 0.65 mm, 16-signal	1
10467-68701	0.5mm IC clips for surface SMT parts with lead spacings of 0.5 mm (.020 in) to 0.8mm (0.32 in)	4

### PC Board Mini-Probe Sockets

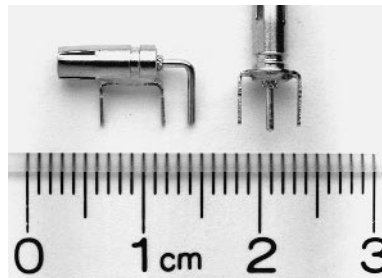

The PC board mini-probe sockets are ideal for reliable, stable, and convenient connection between the probe tip and the circuit under test. These probe sockets are designed for use with the 1160A-family and 10400B-family of passive probes.

### Ordering Information

- N2765A Horizontal Mini-Probe Socket, qty 5
- N2766A Horizontal Mini-Probe Socket, qty 25
- N2767A Vertical Mini-Probe Socket, qty 5
- N2768A Vertical Mini-Probe Socket, qty 25



The 1170A Low Mass Passive Probe

The 1170 family of low mass high performance passive probes for the Infinium Oscilloscopes is designed specifically to make the probing of fine pitch ICs and dense circuit boards easier. The probe tip is exceptionally small and light, weighing less than 1 gram, so it is easier to attach to those small devices and surface mount ICs. Even though small and light, these probes are designed for high performance and the ruggedness required for general purpose use. The cable is re-enforced with Kevlar for added pull strength.

The probe also includes a no-slip browser for precise and safe browsing. The crown point of the browser digs in to solder and won't slip and the pogo pin allows small movements without losing contact.

The 1170A family of probes will connect directly to the Wedge probe adapter for an easy hands-free solution for probing 0.5 and 0.65 mm IC packages. See pages 128 for more information

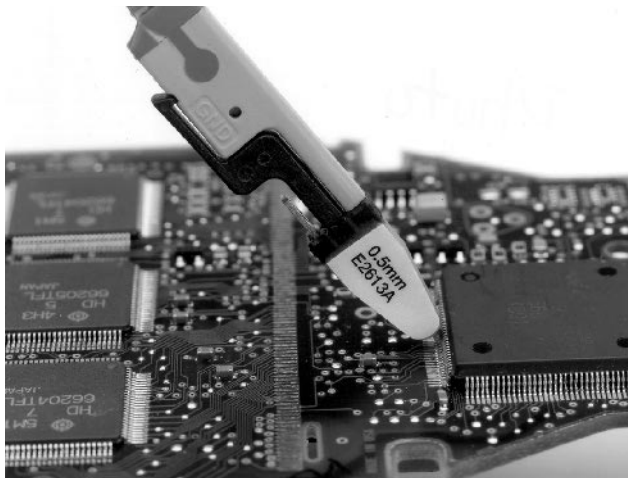

Easy hands-free connection to fine pitch ICs using the Wedge and 1170A probe.

All probes come complete with a range of accessories for both general purpose probing and the probing of fine pitch ICs and dense circuit boards.

The 1170A family of probes is compatible with the AutoProbe Interface, which completely configures the Infinium Oscilloscope for the probe.

Model	Length	Division Ratio	Circuit Loading	System Bandwidth (scope and probe)	Oscilloscope Input
1170A	1.5m	10:1	10 MOhm; 9 pF	500 MHz	1 MOhm; 6–9 pF
1171A	1.4m	10:1	10 MOhm; 10 pF	500 MHz	1 MOhm; 12–14 pF
1172A	1.3m	20:1	10 MOhm; <5 pF	500 MHz	1 MOhm; 6–9 pF
1173A	1.2m	20:1	10 MOhm; <5 pF	500 MHz	1 MOhm; 12–14 pF

### 1170A Family Replacement Parts

#### Ordering Information

##### Fine Pitch IC Probing Accessories

- E2613A** Wedge probe adapter, 0.5 mm, 3-signal, qty1
- E2613B** Wedge probe adapter, 0.5 mm, 3-signal, qty2
- E2614A** Wedge probe adapter, 0.5 mm, 8-signal, qty1
- E2615A** Wedge probe adapter, 0.65 mm, 3-signal, qty1
- E2615B** Wedge probe adapter, 0.65 mm, 3-signal, qty2
- E2616A** Wedge probe adapter, 0.65 mm, 8-signal, qty1
- E2643A** Wedge probe adapter, 0.5 mm, 16-signal, qty1
- E2644A** Wedge probe adapter, 0.65 mm, 16-signal, qty1
- 10467-68701** 0.5mm IC clips for surface SMT parts with leg spacing of 0.5 mm (.020 in) to 0.8mm (0.32 in), qty 4

##### Other Accessories

- E9638A** Probe tip to BNC adapter

### Fine-Pitch Probing Kits

#### A Complete Solution at a Bargain Price!

These fine-pitch probing kits take the 1170A family of probes and add the most useful accessories to give you a versatile and complete probing solution. Each kit includes 2 1170A-family probes (20:1 models) and related accessories, 2 of the 0.5 mm Wedge probe adapter, 4 of our 0.5 mm IC clips and 10 standard IC clips. All for a price substantially less than the individual parts.

#### Ordering Information

- E2652A** Fine-pitch probing kit for the 54810/15/20/25A Infinium Oscilloscopes
- E2653A** Fine-pitch probing kit for 54835A and 54845A Infinium Oscilloscopes

1170A Series  
10467–68701  
E2613A  
E2613B  
E2614A  
E2615A  
E2615B  
E2616A

10467-68701  
10072A  
10450A  
10467A  
E2613A  
E2613B  
E2614A  
E2615A  
E2615B  
E2616A  
E2643A  
E2644A

- Easy connection to 0.5mm, 0.65 mm TQFP and PQFP packages
- Reliable contact with little chance of shorting to adjacent pins
- Mechanically noninvasive
- Can be inserted while the board is active
- 3, 8, and 16-signal versions

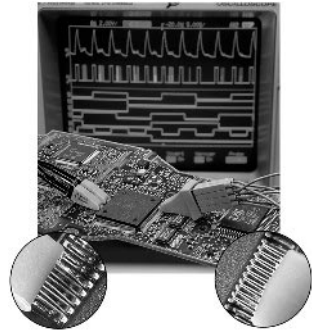

At one end, Wedge conductor segments are inserted into the space between IC pins; at the other end, they easily connect to scopes and logic analyzers.

4

### Wedge Probe Adapter

#### Precise Problem-free Probing

The AgilentWedge probe adapter solves the problem of connecting your scope or logic analyzer to fine pitch thin quad flat pack (TQFP) and plastic quad flat pack (PQFP) surface mount ICs. It provides accurate, mechanically noninvasive and reliable electrical contact to 0.5 and 0.65 mm IC packages, with little chance of shorting. It is available in 3-, 8-, and 16-signal versions.

#### Easy to Insert, Then Stays Put

It works by inserting compressible dual conductors between adjacent IC pins. The flexible conductors conform to the size and shape of each leg to ensure tight contact. It's then a simple matter to connect your scope or logic analyzer to the Agilent Wedge.

#### Electrical Reliability

The Wedge's unique design delivers secure redundant contact on each pin, with little chance of shorting to adjacent pins. The redundant physical connection created by two contact points on each pin of the IC and its short electrical length dramatically increases the reliability of the electrical connection. Since the Agilent Wedge doesn't latch directly onto the IC and doesn't require expansion beforehand (as a clip does), it can be inserted while the board is active. Plus, it's mechanically noninvasive so it won't damage your device under test.

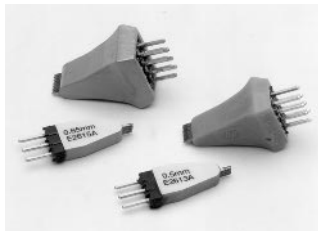

3- and 8-signal versions for 0.5 and 0.65 mm IC Packages

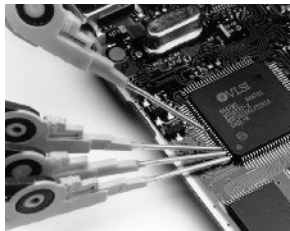

10467-68701 0.5 mm IC Clips

### 0.5 mm IC Clips

These IC clips are the smallest in the industry to date and are suitable for connecting to PQFP and SOIC SMT packages from 0.5 – 0.8 mm pitch. The thin body allows clips to be mounted side by side for probing adjacent IC pins. They are suitable for use with all Agilent oscilloscope probes and logic analyzers and have a maximum input voltage of  $\pm 40V$  (dc + peak ac).



10467A 0.5 mm IC Clip Accessory Kit

#### 10075A and 10467A 0.5 mm IC Clip Accessory Kit

These kits include four 0.5mm IC clips (10467-69701) and two dual-lead adapters for use with the passive probes. Plug the probe tip into one end of the adapter and connect the IC clips to the other end.

The 10075A is compatible with the 10070A family of passive probes. The 10467A is compatible with the 10400A family of passive probes. The 1160A and 10400B family of probes include a dual-lead adapter as a standard accessory. For these probes the accessory kit is not required. Order the IC clips 10467-68701.

#### Ordering Information

- E2613A Wedge probe adapter, 0.5 mm 3-signal, qty 1
- E2613B Wedge probe adapter, 0.5 mm 3-signal, qty 2
- E2614A Wedge probe adapter, 0.5 mm 8-signal, qty 1
- E2615A Wedge probe adapter, 0.65 mm 3-signal, qty 1
- E2615B Wedge probe adapter, 0.65 mm 3-signal, qty 2
- E2616A Wedge probe adapter, 0.65 mm 8-signal, qty 1
- E2643A Wedge probe adapter, 0.5 mm 16-signal, qty 1
- E2644A Wedge probe adapter, 0.65 mm 16-signal, qty 1
- 10467-68701 0.5 mm IC Clips, qty 4
- 10467A 0.5 mm IC Clip Accessory Kit
- 10072A SMT probe accessory kit

### 10072A SMT Probe Accessory Kit

The 10072A includes 10 SMT lead clips that adapt the 10070A family of low-cost probes to fine-pitch devices.

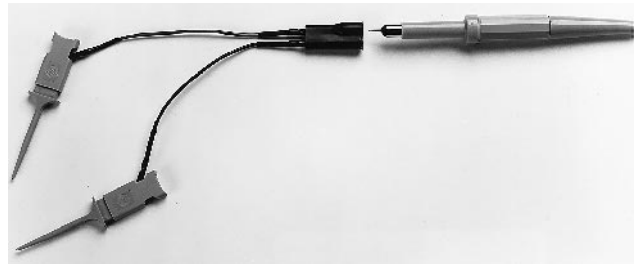





### 1141A Differential Probe with 1142A Power Supply

The 1141A is a 1X FET differential probe with 200 MHz bandwidth and a 3000:1 CMRR (Common Mode Rejection Ratio). The probe has a high-input resistance and low-input capacitance of 7pF to minimize circuit loading. The 1141A must be used with the 1142A probe control and power module, which controls input coupling modes dc, dc with variable offset, and dc reject. Two attenuators, 10X and 100X, are provided to expand the linear differential input range to  $\pm 30V$ .

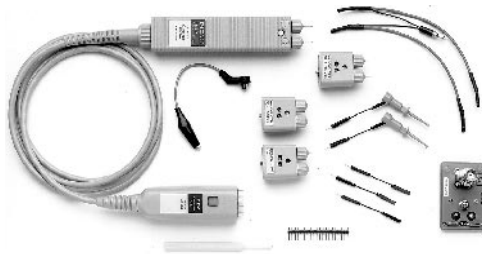

### 1153A 200 MHz Differential Probe

The 1153A is a 200 MHz Differential Probe for use with Agilent Infiniium Oscilloscopes. It is a 1X FET differential probe with 200 MHz bandwidth and 3000:1 CMRR (Common Mode Rejection Ratio). The probe has high-input resistance of 1 MOhm and low-input capacitance of 7 pF to minimize circuit loading. The 1153A is compatible with the AutoProbe Interface, which provides power and completely configures the Infiniium Oscilloscope for the probe.

Input coupling modes include dc, dc with variable offset, and If reject. Two attenuators, 10X and 100X, are provided to expand the linear differential input range to  $\pm 30V$ .



### N2772A Differential Probe with N2773A Power Supply

NEW

The N2772A is a new active differential probe compatible with any of the 54600 series oscilloscopes. With 20 MHz bandwidth and switchable attenuation of 20:1 and 200:1, N2772A provides the versatility for a broad range of applications including high-voltage circuits, motor speed controls, power supply design, electronic high-power converters, and numerous other situations where signals are floating above earth ground.

The N2772A differential probe has an input impedance of 10 MOhm and the CMRR is  $>50$  dB at 1 MHz.

The probe requires a 9V dc battery or N2773A power supply. The power supply has selectable ac frequency settings for 115V and 230Vac at 50 Hz, 60 Hz, and 400 Hz.



### 1154A, 1159A Differential Probes for Infiniium

NEW

The new 1154A and 1159A are high bandwidth differential probes compatible with Infiniium family oscilloscopes. The 1154A offers 500 MHz bandwidth with flexibility of 10X gain and 10:1 attenuation for a maximum of 100:1 attenuation. The 1159A gives you 1 GHz bandwidth and 1:1 attenuation, making it ideal for fast, low voltage signals.

The new 1154A and 1159A differential probes have an input resistance of 1 MOhm and low input capacitance of  $<6$  pF to minimize circuit loading. The CMRR is  $>40$  dB at 10 MHz for 1154A and  $>19$  dB at 500MHz for 1159A without external attenuators connected. The 1154A and 1159A are compatible with the AutoProbe interface which completely configures the Agilent Infiniium Oscilloscope for the probe. The probes also feature external AC coupling to eliminate dc for simplified measurement of ac voltage. These probes connect directly to the Wedge probe adaptor to make probing fine-pitch devices easier to use and more reliable.

### Ordering Information

- 1141A 200 MHz Differential Probe
- 1142A Power Supply
- 1153A 200 MHz Differential Probe
- 1154A 500 MHz Differential Probe
- 1159A 1 GHz Differential Probe
- N2772A 20 MHz Differential Probe
- N2773A Power supply for N2772A

- 1141A
- 1142A
- 1153A
- 1154A
- 1159A
- N2772A
- N2773A

1142A  
1143A  
1144A  
1145A  
1152A  
1155A  
54701A

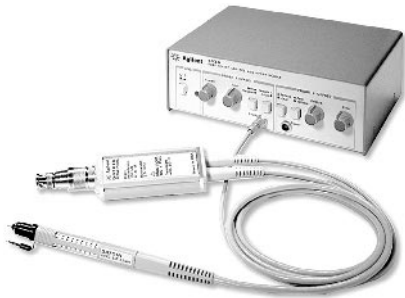

### 54701A 2.5 GHz, 0.6 pF Active Probe with 1143A Power Supply

The 54701A 2.5 GHz, 10:1 active probe provides ultra-low loading of the device-under-test because of its low 0.6 pF capacitive loading and its high 100 KOhm resistive loading. Its 40Vac maximum input voltage, ±15 KV ESD tolerance and replaceable probe tips make the probe extremely reliable.

The 1143A probe offset and power module provides power for 2 54701A probes with any instrument with 50 Ohm input impedance. The power supply is not required if the probe is used with the 54700 series oscilloscopes.

four channels of probing. If the 1144A is used with any scope not listed above, then the 1142A power supply is required. The 01144-61604 adapter can be used with this power supply to provide power for two channels of active probing



### 1152A 2.5 GHz, 0.6 pF Active Probe

The 1152A's 0.6pF, 100 KOhm input provides ultra low loading of the device-under-test, making it an ideal companion for the 54845A 1.5 GHz and 54835A 1 GHz Infiniium Oscilloscope. Its 40Vac maximum input voltage, ± 15 KV ESD tolerance and replaceable probe tips make the 1152A extremely reliable. The 1152A is compatible with the AutoProbe Interface which provides power and completely configures the Infiniium Oscilloscope for the probe.

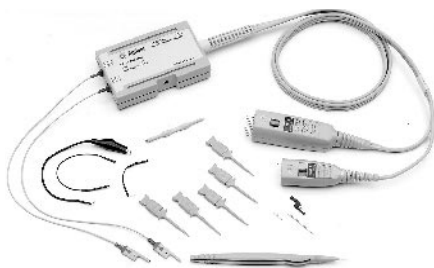

### 1155A Low Mass Active Probe for Surface-Mount Devices

The two-channel 1155A low mass active probe for Infiniium oscilloscopes has a probe tip that weighs less than 1 gram making it ideal for attaching to fine pitch ICs and probing surface mount components. The probe combines high bandwidth (750 MHz), low input capacitance (2 pF), and high input resistance (1 Mohm). A versatile set of accessories are provided, including an Agilent browser with a crown point that digs deep in to solder and a spring loaded tip that helps absorb small movements. When used in conjunction with the Agilent Wedge, the 1155A provides a hands-free solution for probing 0.5 mm and 0.65 mm IC packages. See page 128 for more information.



### 1145A Low Mass Active Probe for Surface-Mount Devices

The two-channel 1155A low mass active probe has a probe tip that weighs less than 1 gram making it ideal for attaching to fine pitch ICs and probing surface mount components. The probe combines high bandwidth (750 MHz), low input capacitance (2 pF) and high input resistance (1 Mohm). A versatile set of accessories are provided and when used in conjunction with the Wedge, the 1145A provides a hands-free solution for probing 0.5mm and 0.65mm IC packages. See page 128 for more information.

This probe can access power directly from the 54520/40 series and 54615/16B oscilloscopes. The 1142A power supply is required for all other instruments. This configuration requires 50 Ohm inputs.



### 1144A 800 MHz Active Probe

The 1144A features 800-MHz bandwidth, 1 MΩ input resistance, 2 pF input capacitance, 10:1 attenuation, and ±40 Vdc + peak ac maximum-input voltage. The 1144A can access power directly from the 54520 and 54540 series and the 54615B and 54616B oscilloscopes. These oscilloscopes provide power for two channels of active probing. If four channels of probing are needed, a special one-input, two-output adapter is available (p/n 01144-61604). Two adapters are needed for

### Ordering Information

- 1142A Power supply for 1144A and 1145A
- 1143A Probe Offset and Power Module for 54701A
- 1144A 800 MHz Active Probe
- 1145A 2-Channel, 750 MHz Active Probe
- 1152A 2.5 GHz, 0.6 pF Active Probe
- 1155A Low Mass Active Probe
- 54701A 2.5 GHz, 0.6 pF Active Probe



### 10076A 100:1 High-Voltage Probe

NEW

The 10076A 4 kV 100:1 passive probe gives you the voltage and bandwidth you need for making high-voltage measurements. Its compact design makes it easier to probe today's small power electronics components and its rugged construction means it can withstand rough handling without breaking. You can measure dc voltages up to 4 kV peak. The 250 MHz probe bandwidth enables you to capture fast, high-voltage signals. The 10077A accessory kit can be used with this high voltage probe for wider range of application.



### N2771A 1000:1 High-Voltage Probe

NEW

The N2771A is a new 1000:1 high voltage probe for the measurement of fast high voltage signals, up to 30 kV dc + peak ac, 10 kVrms and 50 MHz probe bandwidth.

The probe's large size and rugged construction provides superior protection. The ground lead is fed through the body of the probe and protrudes behind the safety barrier, keeping the ground connection away from the high voltage.



### 10020A Resistive Divider Probe Kit

The 10020A Resistive Divider Probe Kit is for measuring fast transition signals in high-impedance systems. It is designed for use with oscilloscopes with 50 Ohm inputs but may be used with other than 50 Ohm systems if a 50 Ohm feedthrough termination is used. The kit includes 6 resistive dividers ranging from 1:1, 50 Ohm to 100:1, 5 KOhm and has an input capacitance of less than 0.7 pF.



### 54006A 6-GHz Passive Divider Probe

The low 0.25 pF input capacitance and sophisticated ground design of the 54006A probe lets you probe multi-GHz systems with minimal loading of the circuit under test. The small size of this probe also allows you to access very small components. The 54006A is supplied with 10:1, 500  $\Omega$ , and 20:1, 1 k  $\Omega$  resistive dividers.

1146A  
10020A  
10076A  
10077A  
54006A  
N2771A

4



### 1146A Oscilloscope AC/DC Current Probe

This ac/dc current probe expands oscilloscope applications into industrial, automotive or power environments, and is ideal for analysis and measurement of distorted current waveforms and harmonics. This probe permits accurate display and measurement of currents from 100 mA to 100 A rms, dc to 100 kHz without breaking into the circuit. The 1146A uses Hall-effect technology to measure ac and dc signals. Compatible with any scope or voltage measuring instrument with BNC input, 0.2 to 0.5 V/div, and a minimum input impedance of 1 MOhm. 1 mV/100 mA Range; Output Signal: 10 mV/A ac/dc. 1mV/10mA Range; Output Signal: 100 mV/A ac/dc. Working Voltage: 660 V max., Battery: 9 V alkaline.

### Ordering Information

1146A Oscilloscope AC/DC Current Probe  
10020A Resistive Divider Probe Kit  
10076A 100:1 High Voltage Probe  
10077A Accessory Kit for 10076A  
54006A 6-GHz Passive Divider Probe  
N2771A 1000:1 High Voltage Probe

## Modulation Domain Analysis: A New View of Complex Signals

As a pioneer of counter/timer technology, Hewlett-Packard recognized a need to expand traditional frequency and time measurement techniques. Now, with modulation domain analyzers, Agilent Technologies offers a unique method for viewing complex signals that is both intuitive and insightful.

Oscilloscopes display amplitude (voltage) versus time: the time domain. Spectrum analyzers show amplitude versus frequency: the frequency domain. The 53310A, E1725C and E1740A bring a new dimension to frequency and time interval analysis with views of the modulation domain:

- Frequency versus time
- Phase versus time
- Time interval versus time

### Improved Measurement Analysis

A wide range of applications benefit from modulation domain analysis. Jitter measurements in digital communication systems, disk and tape drives, and mechanical systems are dramatically improved. Identify the sources of jitter—the first step in improving system performance.

Modulation domain analyzers simplify the study of step response for voltage-controlled oscillators. They easily characterize the frequency-hopping performance of an agile transmitter. Chirp linearity and phase switching in radar systems are easily understood from displays of frequency or phase versus time.

## Modulation Domain Analyzers

Agilent modulation domain analyzers provide a range of features and performance. Analysis features include views of frequency and phase versus time, with built-in statistics and histograms. GPIB programmability lets you control these analyzers remotely, or use the front panel measurement and display options for quick on-the-spot measurements.

The 53310A combines modulation domain analysis in a low-cost offering. Single-button functions and automated setup and measurement capabilities make the 53310A the easiest to operate of the modulation domain analyzers. The 53310A Option 031 includes features that further simplify the analysis steps for RF mobile communications designers, and Option 305 provides software for complete phase analysis.

**53310A:** Affordable, easy-to-use modulation domain analyzer

### Time Interval Analyzers

Agilent's expertise with modulation domain analyzer technology has resulted in a family of time interval analyzer (TIA) products tuned for specific applications. Choose from preconfigured instruments, or design your own solution using the basic TIA module and selecting from a range of software offerings.

The E1725C TIA is based on the E1740A TIA module, a VXI card that can be plugged into a VXI cardcage. The on-card functionality includes basic arming and measurement control and a large 512K memory for storing results. Histograms are also executed in hardware on the E1740A for accelerated analysis operations.

The E1725C instruments combine the E1740A in a VXI cardcage with a portable computer. The computer's Microsoft Windows interface and optional Agilent software packages simplify measurements and offer powerful display and analysis capabilities for viewing and interpreting measurement results.

**E1740A:** Two-slot VXI module

**E1725C:** Highest performance time interval analyzer with configurable personalities

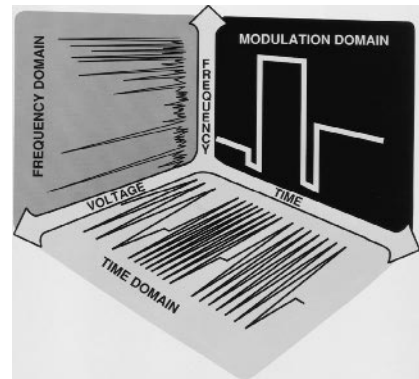

The Modulation Domain adds a third dimension of frequency vs. time

### Application Solutions

With a range of add-on software packages, the E1725C TIAs can be tailored as complete solutions for specific applications. The current family of E174XA software products provide full-function and easy-to-use platforms for these complex measurement situations:

**Data storage:** Evaluate designs and troubleshoot problems for today's high-speed digital storage solutions.

**Clock jitter:** Study and solve jitter problems in clock distribution networks.

**SONET/SDH networks:** Evaluate existing equipment for use with new high-speed technologies.

**Network Synchronization** Determine compliance with industry standards.

**E1741A/E1747A:** Data storage test analysis

**E1742A:** SONET/SDH tributary jitter analysis

**E1743A:** Clock jitter analysis

**E1748A:** Multiple-channel network synchronization measurement

### Modulation Domain Analyzer Selection Guide

Model	Key selection criteria	Feature highlights
53310A	Low-cost, easy to use	Auto set-up RF transmitter characterization features Fast histograms
E1725C	Highest performance analyzer	80 MHz sample rate Microsoft Windows user interface with custom analysis software
E1740A	2-slot VXI module	High performance histograms, window margin analysis, statistics 512K on-card memory



### Modulation Domain Analyzer Applications

The application examples on this page and the next illustrate some of the many situations that benefit from Agilent Technologies modulation domain analyzers. For complete product specifications or to arrange a product demonstration, contact the Agilent Call Center in your region.

#### Modulation Analysis for Mobile Communications

The 53310A's Option 031 "Digital RF Communications Analysis/High Resolution 2.5 GHz Input" provides automatic measurements of synthesizer settling time, Frequency Shift Keyed (FSK) center frequency, and FSK peak deviation on DECT, CT2 and CT3 radios. Features for optimizing RF designs include:

- High resolution measurements—built-in downconversion provides superior frequency resolution for RF signals.
- RF envelope trigger—simplifies measurement setup by automatically triggering on a detected TDMA burst.
- Automatic measurements—synthesizer settling time, Frequency Shift Keyed (FSK) center frequency, and FSK deviation.

Option 305 phase analysis software adds the power of phase analysis to your 53310A. Direct phase analysis lets you measure digital communication systems and extract data, including phase settling time, phase noise (phase spectrum), phase deviation, and phase trajectory. When used in combination, Options 031 and 305 allow direct profiles of both wide- and narrowband modulations up to a 500 KHz modulation rate and eliminate the need for external downconversion.

#### Data Storage Analysis

The E1725C Option 141 instrument is tailored for the specific requirements of data storage analysis. High-speed measurements and large 512K on-board memory allow you to measure a full track on high density hard disk drives and several types of optical disks. Complete acquisition control allows measuring of data edges in the presence of servo or header fields. The Option 141 TIA software can be combined with the Option 147 timing pattern analysis software to provide powerful display and analysis capabilities:

- Window margin analysis and histograms for understanding drive timing (view peak shift, jitter, worst-case data patterns).
- Flexible measurement setup for measuring the edges of your choice, specifying trigger delays and measurement duration, and pacing measurements.
- Sequential displays for characterizing PLL dynamics, viewing spindle speed variations, or verifying correctly written data patterns.
- Computed clock for measuring to an ideal reference.
- Timing pattern analysis for studying worst-case data patterns or viewing problematic data patterns and the surrounding code spacings.
- Online Help for quick answers to operation questions.
- Data export capability for transferring results to another analysis package or to spreadsheet or wordprocessor packages.

#### Characterization and Reduction of Clock Jitter

The E1725C Option 243 TIA and clock jitter analyzer software provides digital designers with a powerful tool for understanding and reducing clock jitter. High-speed clock distribution networks are critical for high performance digital systems. The clock buffers found in these networks—PLLs, frequency dividers, fanout and translation ICs—are also affected by jitter.

The E1725C Option 243 includes powerful jitter measurement and display capabilities:

- Capture every clock cycle up to 80 MHz, continuously for a trillion cycles using fast histogram or 256K cycles using a vs. time display.
- Understand true peak-to-peak and cycle-to-cycle jitter using a complete range of statistics.
- Display jitter spectrum (using a built-in FFT) to determine the root causes of jitter.
- View the phase power spectral density display to see phase noise as noise power offset from the carrier.
- Use the Allan variance display to understand the type and level of noise (white phase, flicker phase, random walk phase, flicker FM, random walk FM, and white FM).
- Export data to another analysis package or to spreadsheet or wordprocessor packages.

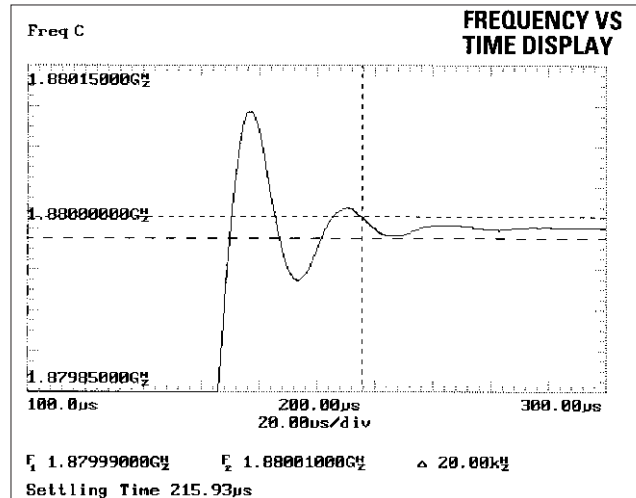

Settling time is displayed automatically on this direct measurement of the synthesizer step.

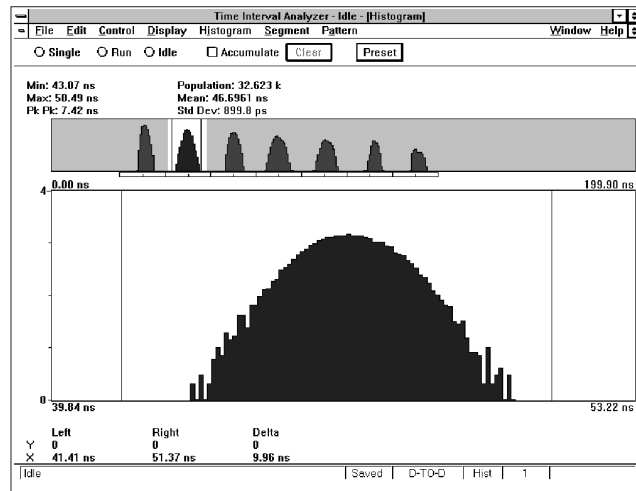

The E1741A features extensive statistical, histogram, and window margin analysis features to simplify jitter characterization in data storage products.

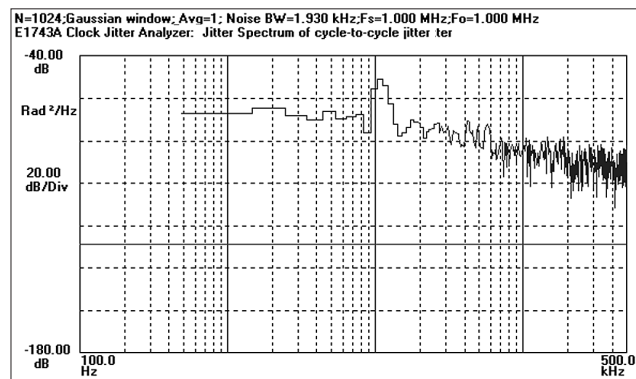

The E1743A phase power spectrum feature allows you to examine jitter spectrum, in this case of cycle-to-cycle jitter on a clock signal. A jitter component near 10 kHz can be easily identified.

## SONET/SDH Tributary Jitter Analysis

When integrating new SONET/SDH technologies with existing telecommunications equipment, network equipment designers use the E1725C TIA Option 242 tributary jitter analyzer software to make sure that new designs conform to standards. Agilent's unique software clock extraction scheme and software filters provide consistent, repeatable results when measuring jitter. The display screens make it easy to examine mapping jitter, pointer-induced jitter, and waiting time jitter.

After a measurement is performed, the E1742A software (included in Option 242) extracts the clock signal and performs a variety of analysis functions:

- Phase deviation display shows the cumulative phase difference of a signal relative to the extracted clock.
- Jitter display uses a built-in 10 Hz high pass filter to simultaneously display peak-to-peak jitter, positive peak, negative peak, mapping jitter, and other jitter components.
- Power spectrum display shows the frequency components which contribute to the jitter and gives a better understanding of the jitter sources.
- Frequency deviation display explains the effect of a pointer hit on the desynchronizer phase lock loop inside a network element.
- Allan variance, TVAR, and FFT functions enhance further study and analysis of the tributary jitter. Each measurement can be stored for future analysis. Graphic and numeric results can be transferred to other Windows applications for inclusion in documents or spreadsheets.

## Ensure Compliance with Network Synchronization Standards

Network synchronization problems can lead to slips and degrading voice, fax and video services. The E1748A network synchronization measurement software, available as Option 248 with the E1725C TIA, gives network managers a powerful tool for evaluating network synchronization and ensuring compliance with industry standards.

All measurements adhere to ITU (CCITT) 0.171, Bellcore and ANSI requirements. On an operational network, MTIE and TDEV are measured and plotted against proposed ITU, ANSI, and ETSI masks for fast reviewing of results. With these measurements, network managers can characterize SSUs and SDH switches. MTIE can be measured over long times, sampling at the ITU-specified rate of 80 samples per second. A unique software clock extraction scheme and software filters result in consistent, repeatable results. Measurement times can be extended even further utilizing concatenation available with the E1748A software. As industry standards evolve, the masks, sample rates, and filters used by the E1748A software package can be updated.

Jitter levels are accurately measured with the E1748A and the E1725C TIA. Its unsurpassed timing resolution of 100 ps rms, combined with the power of its Phase Power Spectral Density plot, deliver enough detail to determine which network components are improving or degrading incoming signals.

The E1748A multiple-channel network synchronization measurement software shortens measurement time on multiple channels with simultaneous recording of channels. Overlay displays offer quick visual comparison of data obtained from multiple MTIE or TDEV measurements.

A scrolling text window below the data display automatically records every action the instrument takes and records every result. This includes marker clicks and other actions performed in order to read, examine, or interpret results. Custom notes can be intermixed in this file to record important information such as type/length of cable, number of PHYs, pass/fail, and so forth. The file can be saved and used in reports or other documents to provide a complete record of the test.

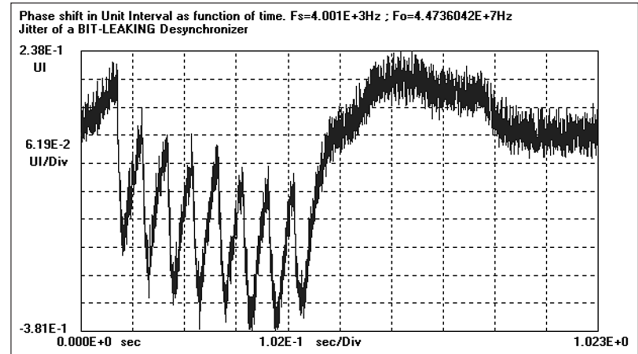

This E1742A display shows the peak-to-peak jitter during an 8 UI phase transient. The phase transient is being leaked out to the tributary over 0.5 seconds one bit at a time.

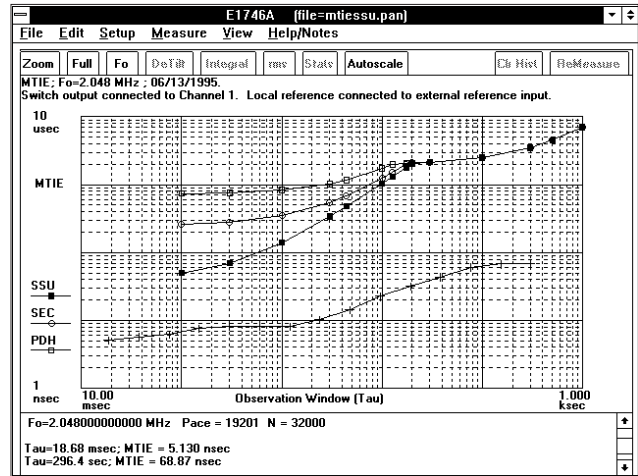

Typical MTIE measurements made with E1748A multiple channel network synchronization measurement software show sufficient margin compared to ETSI draft DE/TM 3017 masks. The four simultaneous measurements show, however, degradation from cascading timing signals.

- 200 ps rms single-shot resolution, 1 ps with averaging
- DECT, CT2, CT3 mobile communications measurements
- Easy to use

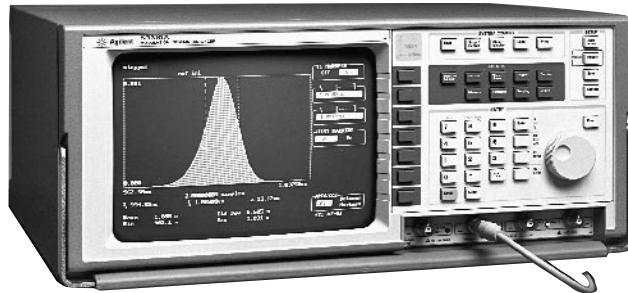

53310A

### 53310A Modulation Domain Analyzer



#### Affordability and Ease of Use

The most affordable modulation domain analyzer, the 53310A, includes many innovations for ease of use. Characterization of modulation and jitter is easy with built-in analysis. Parameters such as peak-to-peak deviation, carrier frequency, and modulation rate are all quickly and automatically displayed. Jitter analysis is simplified with automated mean, standard deviation, and probability functions. Key features of this frequency and time interval analysis product include:

**Automated setup:** A single button can set up the 53310A for measurement. Signals are automatically evaluated.

**Single-touch measurements:** Peak-to-peak deviation, carrier frequency, and modulation rate are easily and quickly measured for quantifying modulation. The Save/Recall function stores up to 10 measurement steps for fast repeat operations.

**Built-in statistics:** Mean, standard deviation, and probability function buttons simplify jitter analysis.

**Softkey-driven menus:** Measurement parameters and analysis functions are easily selected while viewing measurement data.

**Large display:** The expanded screen displays measurement results clearly and aids analysis.

**Low cost:** The 53310A is priced to fit budget-constrained projects and departments.

#### Product Features

The 53310A offers powerful analyzer features:

**Dual timebases:** Main timebase and window timebase allow data capture while viewing measurement details in the window.

**Auto or triggered operation:** Select auto triggering, edge triggering (rising or falling), or a unique feature: measurement value triggering (frequency or time interval). Value triggering can eliminate the need for and expense of external sync signal generation, shortening project time and lowering costs.

**Display vs. time or histogram:** Select appropriate views.

**Fast histograms:** Up to 16 million measurements per acquisition.

**Automated measurements:** Autoscale selects appropriate setup parameters; built-in analysis functions eliminate calculations.

#### Specifications and Ordering Information

See page 136 for key specifications and ordering details.

- Highest performance TIA
- Fast histograms, statistics, and window margin analysis
- Analyze data storage devices
- Study and identify clock jitter
- Analyze jitter in SONET/SDH networks

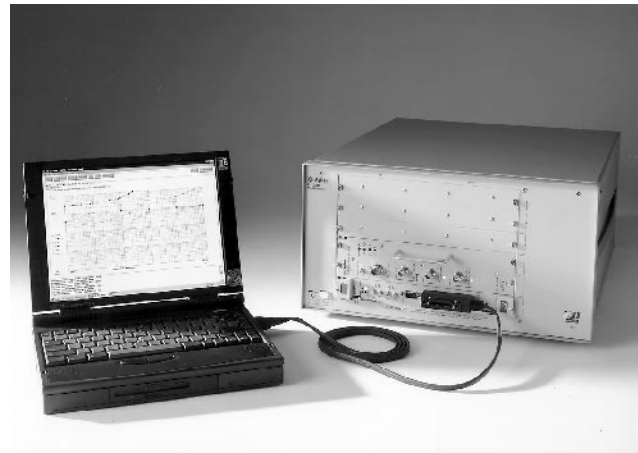

E1725C

### E1725C Time Interval Analyzer



The E1725C time interval analyzer (TIA) combines a fast measurement sampling rate with a large memory and advanced analysis capabilities. Optional software packages, purchased separately or as options with the E1725C system, tailor the instrument to meet a variety of demanding application areas.

#### Advanced Analysis Software

The current E174XA software solutions address four application areas described in the two previous pages of this catalog. These applications and corresponding software include:

- Data storage and test: E1741A and E1747A
- SONET/SDH tributary jitter analysis: E1742A
- Clock jitter analysis: E1743A
- Multiple-channel network synchronization measurement: E1748A

#### Versatile Design and Operation

Tailored for benchtop use, the E1725C system integrates a high performance time interval analyzer with an external portable computer based on an Intel processor. The MS<sup>®</sup>-Windows interface streamlines setup and offers complete control of measurement and analysis parameters. Measurements are carried out and stored in the instrument's 512K of memory. Built-in histograms, window margin analysis, and statistics functions speed access to many results.

For customers who desire a VXI solution, Agilent offers the E1740A time interval analyzer card. The E1725C benchtop instrument and E1740A VXI TIA card offer equivalent measurement capabilities, and the software packages that run on the E1725C can be purchased as add-on products for the E1740A.

#### Specifications and Ordering Information

See page 136 for key specifications and ordering details.

53310A  
E1725C  
E1740A  
E1741A  
E1742A  
E1743A  
E1747A  
E1748A

# Modulation Domain Analyzers

136

## Modulation Domain Analyzers

Summary

### Modulation Domain Analyzer Specification Highlights

Model	Frequency range (extension)	Single-shot freq. res. (1s gate)	Time interval resolution (single-shot/averaging)	Maximum continuous meas. rate (meas/s)	Memory size	Output meas/s	Analysis and display
53310A	200 MHz (2.5 GHz)	10 digits	200 ps/1ps	2.5 M	8000 (32,000 w/Option 001)	GPIB: to 7,500	Frequency and time interval vs. time; auto-scale (setup); large display; jitter analysis; simple triggering; digital RF communications (Option 031)
E1740A E 1725C	150 MHz	10 digits	100 ps/1ps	80 M	512K	6,500; VXI shared memory available	Frequency, time interval, time stamps, histogram, statistics, and window margin analysis. Additional analysis and display capability available using the E174xA software.

### Ordering Information

#### 53310A Modulation Domain Analyzer

- Opt 001** Extended Measurement Memory (4 x)
- Opt 010** High Stability Oven Timebase
- Opt 030** 2.5 GHz Channel C
- Opt 031** Digital RF Communications Analysis/High Resolution 2.5 GHz Input
- Opt 305** Phase Analysis Software
- Opt W30** 3-Year Extended Repair Service
- Opt W32** 3-Year Calibration Service
- Opt W34** 3-Year Standards Compliant Cal Service
- Opt W50** 5-Year Return Repair Service
- Opt W52** 5-Year Return Calibration Service
- Opt W54** 5-Year Standards Compliant Cal Service

#### Available Separately

53305A Phase Analysis Software

#### E1725C Time Interval Analyzer

Includes E1740A TIA module, E1406A Command Module, HP OmniBook portable computer, MS-Windows 98 MS-DOS 6.22, National Instruments PCMCIA-GPIB kit, and 4 oscilloscope probes.

- Opt 002** Replace 6-slot card cage with E1401A 13-slot mainframe
- Opt 141** Time Interval Analyzer Software
- Opt 147** Timing Pattern Analysis Software
- Opt 242** SONET/SDH Tributary Jitter Analyzer Software
- Opt 243** Clock Jitter Analyzer Software
- Opt 248** Multiple-channel Network Synchronization Software
- Opt W32** 3-Year Service
- Opt W50** 5-Year Return Repair Service
- Opt W52** 5-Year Return Calibration Service

#### Available Separately

- E1740A Time Interval Analyzer Module
  - Opt W32** 3-Year Return Calibration Service
  - Opt W50** 5-Year Return Repair Service
  - Opt W52** 5-Year Return Calibration Service
- E1741A Time Interval Analyzer Software
- E1742A SONET/SDH Tributary Jitter Analyzer Software
- E1743A Clock Jitter Analyzer Software
- E1747A Timing Pattern Analysis Software
- E1748A Multiple-channel Network Synchronization Software



## Electronic Counters

Starting with the first frequency-measurement projects in the 1940s, Hewlett-Packard pioneered the major technologies enabling today's electronic counters and modulation-domain analyzers. Today, Agilent Technologies offers the industry's broadest line of electronic counters and counter/timers.

Electronic counter/timers are used throughout most technical industries for measuring and analyzing frequency, phase, and time-interval signal characteristics. The breadth of the Agilent offering allows the best product to be selected for each application. An ideal functional and performance fit delivers the greatest value: the best and most cost-effective solution.

Agilent counter/timers offer:

- High-measurement accuracy
- Fast system throughput/GPIB capability
- Low cost of ownership
- Ease of use
- Data reduction on many models
- Triggering simplicity

## New Measurement Technology

Modulation domain products feature "continuous count" technology. Unlike traditional counters, these products do not stop between measurements to process data. Rather, they measure continuously and process results on the fly. As a result, new kinds of measurements are made possible.

Modulation domain products include:

**53310A:** Combines affordability and ease of use

**E1725C:** Highest performance time-interval analyzer

**E1740A:** 150 MHz time-interval analyzer; high-performance analysis for VXI systems

For more information on modulation domain products, see the section starting on page 132.

## Counter Products

### RF Counter



The 53181A RF counter offers outstanding measurement performance in a low-cost, easy-to-use package.

The 53181A leads off Agilent's newest line of frequency counters. The 53181A RF counter employs continuous measurement technology to provide superior performance at a very low price. Frequency and period measurements are provided over the range of 0.1 Hz to 225 MHz with exceptional resolution of 10 digits in one second. An optional second channel increases the frequency range to 1.5 GHz, 3 GHz, 5 GHz, or 12.4 GHz, making it easy to cover your exact RF measurement needs. Other features of the 53181A include GPIB, automatic limit testing, analog display mode, single-button recall, extensive in-box statistical and math analysis, and more.

The 53181A RF counter is designed for systems and bench applications where high-precision frequency measurements are required in an easy-to-use, small and rugged package.

**53181A:** The low-cost RF counter for systems and bench use

### Universal Counters



The 53131A universal counter offers high performance for system or bench.

The Agilent universal counter/timers incorporate frequency measurements, just like the 53181A, and additional capabilities for time-interval measurements. Specifically, these counters measure precise timing between two trigger events. These high-performance universal products also provide complete, automatic characterization of rise time, pulse width, and other signal parameters. Options are available (frequency extensions, high-precision time bases) to customize the products.

The current Agilent universal counter offering includes two high-performance universal counters: the 53131A and 53132A.

The 53131A is designed for manufacturing test, troubleshooting, and service. This counter allows you to easily make highly reliable frequency and timing measurements. Featured are extensive in-box analysis, automatic limit testing, analog display mode, single button recall, and more. The 53131A's half-rack size and light weight make it well suited for both benchtop and rackmounting.

The 53132A is designed for high-performance ATE systems. It combines the functionality of the 53131A with improved frequency and time interval resolution.

**53131A:** High-performance system and bench counter (10 digits/sec. and 500 ps LSD)

**53132A:** Highest resolution universal counter for system applications (12 digits/sec. and 150 ps LSD)

### Microwave and Millimeter-Wave Frequency Counters

These products provide fundamental high-performance frequency measurements, dc to 46 GHz. Many enhancements—power measurement, battery operation, systems interface (GPIB), and high-accuracy time bases—are available standard or as options.

Pulse counters add the capability to automatically measure and profile burst or pulsed microwave or millimeter-wave signals.

**53150A/53151A/53152A:** Portable CW microwave counter with power measurement for telecommunications service

**53147A/53148A/53149A:** Portable CW microwave counter with dc DVM plus true power meter for improved power accuracy

### High-Precision Oscillators

The accuracy of frequency and time-interval measurements is vitally dependent on the time base or reference element selected. Agilent has pioneered the field of high-precision crystal oscillators. The current counter product line benefits from Agilent's leadership in quality and precision oscillator technology. Three oscillator varieties are standard or optional with Agilent counters and counter/timers:

**RTXO:** Room-temperature crystal oscillators are designed for minimum frequency change over a change in temperature

**TCXO:** Temperature-compensated oscillators use external components to offset temperature effects. TCXO time bases have temperature characteristics which are typically five times better than an RTXO, or  $<5 \times 10^{-7}$  for a  $0^\circ$  to  $50^\circ$  C change.

**Oven Time Base:** This alternative places the crystal and temperature-sensitive elements within a temperature-controlled environment. A heating element maintains a consistent temperature. The best stability is achieved when the operating point is  $15^\circ$  to  $20^\circ$  C above the highest temperature to which the unit will be exposed. After warm-up, the frequency remains very stable, typically  $<7 \times 10^{-9}$  over a  $0^\circ$  to  $50^\circ$  C variation.

For more information, please request Application Note 200-2, "Fundamentals of Quartz Oscillators" from the Agilent Call Center in your region.

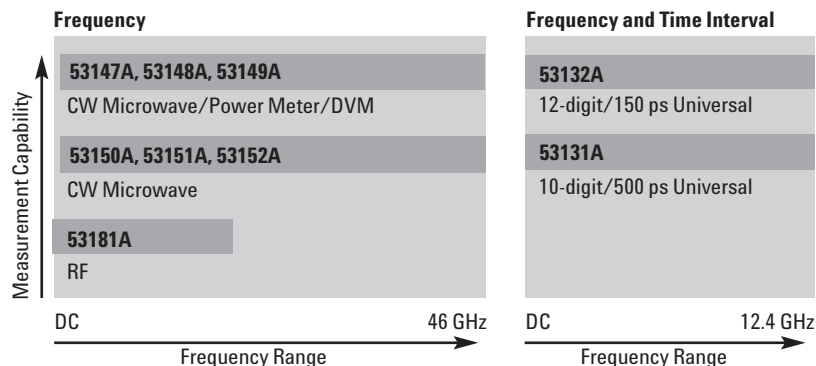

## Counter Selection Guide

Model	Frequency range (extension)	Freq. resolution (1 s gate time)	Best sensitivity	Time-interval res. (single-shot LSD)	Additional features	Page
<b>Universal Counters</b>						
53131A	225 MHz (3, 5, 12.4 GHz)	10 digits	20 mVrms	500 ps	GPIB standard, full math, statistics, limit testing, auto pulse characterization	139
53132A	225 MHz (3, 5, 12.4 GHz)	12 digits	20 mVrms	150 ps	GPIB standard, full math, statistics, limit testing, auto pulse characterization	139
<b>RF Counter</b>						
53181A	225 MHz (1.5, 3, 5, 12.4 GHz)	10 digits	20 mVrms	—	GPIB standard, full math, statistics, limit testing	139
<b>CW Microwave Counters</b>						
53150A	20 GHz	1 Hz	-30 dBm	—	GPIB standard, battery optional, simultaneous power measurement	141
53151A	26.5 GHz	1 Hz	-30 dBm	—	GPIB standard, battery optional, simultaneous power measurement	141
53152A	46 GHz	1 Hz	-30 dBm	—	GPIB standard, battery optional, simultaneous power measurement	141
<b>CW Microwave Counter/Power Meter/DVMs</b>						
53147A	20 GHz	1 Hz	-30 dBm	—	DVM and GPIB standard, battery optional, -70 dBm to +20 dBm true power meter	143
53148A	26.5 GHz	1 Hz	-30 dBm	—	DVM and GPIB standard, battery optional, -70 dBm to +20 dBm true power meter	143
53149A	46 GHz	1 Hz	-30 dBm	—	DVM and GPIB standard, battery optional, -70 dBm to +20 dBm true power meter	143

Indicates QuickShip availability.

Additionally, Agilent offers electronic counters and counter/timers in an industry standard platform: VXIbus. With VXIbus counters from Agilent, you can rely on the same exceptional performance that you have always had from Hewlett-Packard's high-performance rack-and-stack universal counters. All B-size instruments can be adapted to fit

into the C-size VXIbus mainframes. Please request the 2000 Test System and VXI Catalog, p/n 5980-0307E-catalog; p/n 5980-0308E-CD-ROM for additional configuration and product ordering information. Also, see the *VXIbus Products, Agilent 75000 VXIbus Family* section in this catalog.

- High-resolution frequency measurements to 225 MHz (optional 1.5, 3.0, 5.0 or 12.4 GHz)
- High-resolution time-interval measurements with 53131A and 53132A
- Intuitive user interface with shallow menu structure
- GPIB standard with data transfer rate of up to 200 fully-formatted measurements/second; talk-only RS-232
- Limit test capability

- 53181A: 10-digit/s resolution
- 53131A: 10-digit/s and 500 psec resolution
- 53132A: 12-digit/s and 150 psec resolution

53131A  
53132A  
53181A

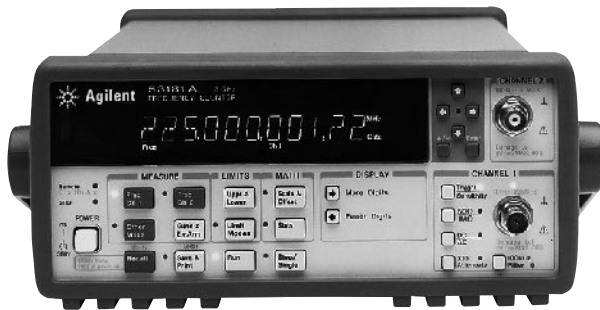

53181A RF Counter



53131A and 53132A Universal Counters

### A Full Family of High-Performance RF and Universal Counters

#### Within Budget, Without Compromise

The 53131A/132A/181A high-performance counters offer exceptional price and performance in a rugged, lightweight package with a unique combination of ease of use, complete measurement set, extensive analysis capability, reliability, and high measurement and data transfer speed.

These instruments use real-time digital signal processing technology to analyze data while simultaneously taking new readings, speeding measurement throughput. The technology, developed for Agilent's high-end line of modulation-domain analyzers, allows the counters to gather more data for each measurement so you get the high-resolution measurements in a fraction of the time it takes a conventional counter.

#### Powerful Analysis Capability

The 53131A/132A/181A counters offer built-in statistics and math functions so you can scale measurements and simultaneously measure and track average, min./max. and standard deviation. Automated limit testing lets you set upper and lower limits for any measurement. When a measurement falls outside those limits, the counters log the out-of-limit conditions, notify the operator and generate an output signal to trigger external devices or stop the test. An analog display mode carries limit testing one step further, letting you see at a glance whether a measurement falls within pass/fail limits.



Analog display mode uses an asterisk to represent the current measurement relative to user-defined upper and lower limits. The colon on the left represents the lower limit and the colon on the right represents the upper limit.

#### High-Speed Automated Test Capability

For computer-controlled systems applications, each counter includes a standard GPIB interface with a data transfer rate of up to 200 fully-formatted measurements per second. The counters use the Standard Commands for Programmable Instruments (SCPI) protocol, letting you leverage your programming investment across your measurement system. The standard RS-232 talk-only interface provides printer support or data transfer to a computer through a terminal-emulation program.

### 53181A RF Counter



Optimized for RF applications, the single-channel 53181A gives you frequency, period, and peak-voltage measurements with up to 10 digits/sec frequency and period resolution. The low-cost 53181A counter is ideal for benchtop, system RF and analog applications.

A digit-blanking function lets you easily eliminate unnecessary digits when you want to read measurements quickly. For higher-frequency measurements, an optional second channel provides 1.5, 3, 5 or 12.4 GHz bandwidth.

### 53131A and 53132A Universal Counters



The two-channel 53131A counter offers 10 digits per second of frequency and period resolution at up to 225 MHz. Single-shot time-interval resolution is specified at 500 ps and averaging can reduce this even further. Measurements include frequency, time interval, ratio, period, phase angle, totalize, peak voltage, pulse parameters and more. For quick access to frequently used tests, a single key-stroke recalls up to 20 different stored front-panel set-ups. Choose the 53131A for general bench or system test where you need excellent performance at an unbeatable price.

For applications requiring higher resolution, the 53132A offers the same features and functions as the 53131A with up to 12 digits/s frequency and period resolution. Single-shot time-interval resolution is specified at 150 ps. Choose the 53132A when you need the very best in accuracy and resolution, or when speed in an automated system is critical. With the 53132A, expanded external arming features can be used to control time interval measurements using an external signal.

Whichever counter you choose, you'll have an accurate, reliable counter that will serve you for years to come. We back that claim with a standard three-year warranty that can be extended an additional two years.

#### Options Increase Versatility

The 53131A/132A/181A counters can be ordered with an optional RF-input channel to provide frequency measurements up to 3 GHz (Option 030), 5 GHz (Option 050) or 12.4 GHz (Option 124). (See table on page 140.)

A choice of optional timebases is available for the 53131A/132A/181A counters to increase your measurement accuracy. Option 010 provides a high-stability oven timebase with aging of less than  $5 \times 10^{-10}$  per day. Option 012 provides an ultra-high-stability oven timebase with aging of less than  $1 \times 10^{-10}$  per day. (See table on page 140.)

BenchLink Meter, 34812A optional software turns your PC and counter into a powerful, easy-to-use measurement system. HP BenchLink Meter lets you easily configure and run tests from your Windows-based PC, making data gathering more convenient. HP BenchLink software helps you get more information from your data by providing a variety of basic display formats and analysis tools that let you manipulate and understand your data quickly and easily.

## Abridged Measurement Specification & Characteristics

	53131A	53132A	53181A
<b>Measurements</b>	Frequency, frequency ratio, time interval, period, rise/fall time, positive/negative pulse width, duty cycle, phase (CH 1 to CH 2), totalize, peak voltage, time interval average, time interval delay		Frequency, frequency ratio (with optional CH 2), period, peak voltage
<b>Analysis</b>	Automatic limit testing, math (scale and offset), statistics (minimum, maximum, mean, standard deviation). Statistics available on all measurements or only measurements that fall within limits.		
<b>Measurement characteristic</b>			
Frequency range	CH 1 & 2: dc–225 MHz	CH 1 & 2: dc–225 MHz	CH 1: dc–225 MHz
Frequency resolution:	10 digits/s	12 digits/s	10 digits/s
Time interval resolution (LSD)	500 ps	150 ps	NA
Measurement speed:	Up to 200 meas/s over GPIB	Up to 200 meas/s over GPIB	Up to 200 meas/s over GPIB
<b>Voltage range &amp; sensitivity (Sinusoid)</b>			
DC to 100 MHz:	20 mVrms to ±5 Vac + dc	20 mVrms to ±5 Vac + dc	20 mVrms to ±5 Vac + dc
100 MHz to 200 MHz:	30 mVrms to ±5 Vac + dc	30 mVrms to ±5 Vac + dc	30 mVrms to ±5 Vac + dc
200 to 225 MHz:	40 mVrms to ±5 Vac + dc	40 mVrms to ±5 Vac + dc	40 mVrms to ±5 Vac + dc
<b>Input conditioning</b>	(Independently selectable on CH 1 & 2)	(Independently selectable on CH 1 & 2)	(Selectable on CH 1)
Impedance, coupling	1 MΩ or 50 Ω, ac or dc	1 MΩ or 50 Ω, ac or dc	1 MΩ or 50 Ω, ac or dc
Low pass filter	100 kHz, switchable	100 kHz, switchable	100 kHz, switchable
Attenuation	x1 or x10	x1 or x10	x1 or x10
<b>External timebase reference input</b>	1, 5, 10 MHz	10 MHz	1, 5, 10 MHz
<b>Trigger</b>	CH 1 & 2 Trigger on rising/falling edge; set level by percent of signal level or absolute voltage; set sensitivity to LOW, MED, or HIGH	CH 1 & 2	CH 1
<b>Gating and arming</b>	Auto, manual (set gate time or number of digits of resolution); external, delay (expanded on 53132A)		
<b>Interfaces</b>	GPIB (IEEE 488.1 and 488.2) with SCPI-compatible language; talk only RS-232		
<b>Power</b>	100 to 120 VAC ± 10% –50, 60 or 400 Hz ± 10% } AC line voltage selection is automatic 220 to 240 VAC ± 10% –50 or 60 Hz ± 10%		
<b>Net weight / size</b>	3 kg (6.5 lbs), 88.5mm H x 212.6mm W x 348.3mm D (3.54 in x 8.50 in x 13.932 in)		

For full specifications, request a Product Overview, or visit our web site: [www.agilent.com/find/bi](http://www.agilent.com/find/bi)

## Standard and Optional High-Stability Timebases

	Standard (0° to 50° C)	Medium Stability Oven (Option 001)	High Stability Oven (Option 010)	Ultra High Stability Oven (Option 012, 53132A only)
<b>Temperature Stability:</b> (referenced to 25° C)	< 5 x 10 <sup>-6</sup>	< 2 x 10 <sup>-7</sup>	< 2.5 x 10 <sup>-9</sup>	< 2.5 x 10 <sup>-9</sup>
<b>Aging Rate</b> (after 30 days) Per Day: Per Month: Per Year:	< 3 x 10 <sup>-7</sup>	< 4 x 10 <sup>-8</sup> < 2 x 10 <sup>-7</sup>	< 5 x 10 <sup>-10</sup> < 1.5 x 10 <sup>-8</sup>	< 1 x 10 <sup>-10</sup> < 3 x 10 <sup>-9</sup> < 2 x 10 <sup>-8</sup>
<b>Turn-on stability vs. time:</b> (in 30 minutes)		< 2 x 10 <sup>-7</sup> (referenced to 2 hours)	< 5 x 10 <sup>-9</sup> (referenced to 24 hours)	< 5 x 10 <sup>-9</sup> (referenced to 24 hours)
<b>Calibration:</b>	Manual Adjust	Electronic	Electronic	Electronic

Note that power to the time base is maintained when the counter is placed in standby via the front panel switch. The internal fan will continue to operate under this condition to maintain long-term instrument reliability.

## Optional High-Frequency Channels

	Frequency range	Coupling	Power range and sensitivity	Damage level
<b>Option 015<sup>1</sup></b> <b>1.5 GHz channel</b>	100 MHz to 1.5 GHz	ac	-27 dBm to +19 dBm	5 Vrms
<b>Option 030</b> <b>3.0 GHz channel</b>	100 MHz to 3.0 GHz	ac	-27 dBm to +19 dBm (100 MHz to 2.7 GHz) -21 dBm to +13 dBm (2.7 GHz to 3 GHz)	5 Vrms
<b>Option 050</b> <b>5.0 GHz channel</b>	200 MHz to 5.0 GHz	ac	-23 dBm to +13 dBm	25 dBm
<b>Option 124</b> <b>12.4 GHz channel</b>	200 MHz to 12.4 GHz	ac	-23 dBm to +13 dBm	25 dBm

<sup>1</sup> Option 015 is available only for 53181A counters.

## Ordering Information

- 53131A Universal Counter
- 53132A Universal Counter
- 53181A RF Counter
- Opt 001 Medium-Stability Timebase
- Opt 010 High-Stability Timebase
- Opt 012 High-Stability Timebase (53132A Only)
- Opt 015 1.5 GHz Ch. w/BNC Connector (53181A only)
- Opt 030 3 GHz Channel with BNC Connector
- Opt 050 5 GHz Channel with Type-N Connector
- Opt 124 12.4 GHz Channel with Type-N Connector
- Opt 060 Rear-Panel Connectors
- Opt 1BP MIL-STD-45662 Calibration w/ Data
- Opt 1CM Rackmount Kit
- Opt W50 Additional 2-year warranty
- 34812A HP BenchLink Meter Software
- 34161A Accessory Pouch
- 34131A Hard Transit Case

 Indicates QuickShip availability.



- Ultra wide range, single input (from 50 MHz up to 46 GHz)
- Simultaneous frequency and power measurement with analog peaking indicator
- Fully programmable via GPIB and RS-232 standard
- Lightweight with optional battery

53150A  
53151A  
53152A



53152A

### 53150A, 53151A, 53152A Microwave Counters

The Agilent 53150 series represent a total re-thinking of microwave counters: innovative designs that offer no-compromise performance and quality while attaining true portability. The 53150A, 53151A, and 53152A measure both frequency and power over the frequency ranges of 20 GHz, 26.5 GHz, and 46 GHz, respectively, and feature a single, extremely wideband microwave input (50 MHz up to 46 GHz).

#### No Compromise Performance

Utilizing a unique single board design with low phase noise PLL circuitry, the 53150 series offers exceptional sensitivity, excellent power measurement accuracy and repeatability as well as fast acquisition times and full programmability. Performance equals or surpasses the industry standard HP 5350 series in virtually every aspect, and in a package that is less than half the weight and size.

#### Frequency and Power Measurements with a Single Connection

The heart of the 53150 series is an advanced sampler design that integrates a separate zero bias Schottky diode for the accurate measurement of input power. This allows the convenient measurement of both frequency and power with a single connection. The unique cable-loss-compensation feature (power correction) yields accuracies and repeatabilities that rival power meters. Best of all, since the frequency of the test signal is measured simultaneously, the diode's frequency response is automatically adjusted for. And like the latest in diode sensors, deviation from square law is also compensated for.

#### Functionality Without Clutter

The 53150 series offers a clean, uncluttered front panel with a minimum of push buttons. Despite their simple appearance, these counters retain all the powerful functions one expects in precision instrumentation, with such useful functions as: measurement averaging, arbitrary as well as nulling offsets for both frequency and power, display of power in either dBm or Watts and full control of resolution, sampling rate, and GPIB address plus extensive self-diagnostics.

#### Field Tough but Ready for Benchtop or ATE Applications

The 53150 series is as comfortable in the field as in the laboratory. The rugged case with an integrated tilting handle can tolerate the vibration and shock expected in field use. For easy transportation, a soft carrying case is also available. The "see anywhere" backlit LCD display ensures visibility in all environments, from dark to full sunlight. And in situations where AC is unavailable, the internal, replaceable camcorder batteries provide over 2.5 hours of continuous operation. Alternatively, the unit can be powered from an external 11-18 VDC source.

For benchtop and ATE applications, the 53150 series delivers full functionality and high measurement speed along with fully programmable RS-232 interface and high speed GPIB (SCPI compliant) as standard. In addition, these counters are compatible with standard Agilent rackmount hardware.

53150A  
53151A  
53152A

## 53150 Series Abridged Measurement Specifications and Characteristics

All measurement specifications are over the full signal ranges of channels 1 and 2. For full specifications, please call your Agilent representative and request a Product Overview for the 53150 series microwave counters.

### Input Characteristics

	Input 1 (1 M $\Omega$ )	Input 2 (50 $\Omega$ )		
<b>Frequency Range</b>				
53150A	10 Hz to 125 MHz	.05–20 GHz		
53151A	10 Hz to 125 MHz	.05–26.5 GHz		
53152A	10 Hz to 125 MHz	.05–46 GHz		
<b>Sensitivity</b>		<b>53150/51</b>	<b>53152</b>	
<30 Hz	40 mVrms		—	—
to 125 MHz	25 mVrms		—	—
<250 MHz	—	–20 dBm	–20 dBm	
to 12.4 GHz	—	–33 dBm	–33 dBm	
to 18 GHz	—	–33 dBm	–30 dBm	
to 20 GHz	—	–29 dBm	–27 dBm	
to 26.5 GHz	—	–25 dBm (151)	–27 dBm	
to 40 GHz	—	—	–23 dBm	
to 46 GHz	—	—	–17 dBm	
<b>Maximum Input</b>	2 Vrms	+5 dBm, < 2 GHz +13 dBm, > 2 GHz		
<b>Damage Level</b>	5 Vrms to 120 Vp	+27 dBm		
<b>Coupling</b>	AC	AC		

### Channel 1

**Resolution:** Selectable 1 Hz to 1 MHz  
**Connector:** BNC female  
**Low Pass Filter:** 50 kHz, selectable

### Channel 2

**Resolution:** Selectable 1 Hz to 1 MHz  
**Acquisition Time:** 100 ms to 140 ms  
**Gate Time:** 1/Resolution  
**FM Tolerance:** 20 MHz p-p max. @ 10 MHz rate to 26.5 GHz;  
12 MHz p-p max. @ 10 MHz rate to 46 GHz  
**AM Tolerance:** Any depth/rate within dynamic range of input  
**Amplitude Discrimination** (above 250 MHz): 20 dB typ. for greater than 75 MHz separation; 10 dB typ. for less than 75 MHz separation  
**Connector:** 3.5 mm SMA compatible (53150A/53151A);  
2.92 mm removable (53152A)

### Power Measurement

**Range:** Counter sensitivity to +7 dBm  
**Units:** dBm or milliwatts/microwatts  
**Resolution:** 0.01 dB

**Accuracy\*** (0 to –20 dBm):

	53150/51	53152
< 12.4 GHz	±1.5 dB	±1.0 dB
to 20 GHz	±1.5 dB	±1.5 dB
to 26.5 GHz	±2.0 dB (151)	±1.5 dB
to 46 GHz	—	±2.0 dB

\*At channel two input connector

### General

**Display:** Backlit LCD  
**Sample Rate:** User-selectable Fast, Medium, Slow or Hold  
**Programming:** GPIB and RS-232C, SCPI compatible

### Math Functions

**Offset:** Last reading and/or entered offset to reading for either power or frequency

**Averaging:** 1 to 99 measurement running average

**Power Correction** (Cable Loss Compensation): Offsets power reading via linear interpolation of up to 10 user-entered frequency attenuations

**Save and Recall:** Up to 9 complete instrument setups may be saved and later recalled

**Sleep Mode** (battery option only): Automatically activated if no input is present for 5 minutes

### Power Requirements

75 VA max. (25 W typ.)

90–132 VAC; 50, 60, 400 Hz

216–264 VAC; 50, 60 Hz

11–18 VDC; 2A max.: battery option only

### Battery (option):

**Type:** VHS camcorder, sealed lead acid (2 each)

**Charge Time:** 8 hours in unit

**Capacity:** 2.5 hours minimum at 25° C

### Timebase:

	TCX0 (std)	Option 001
Aging Rate	1 x 10 <sup>-7</sup> /mo	5 x 10 <sup>-10</sup> /day
Short Term (1 sec. avg.)	1 x 10 <sup>-9</sup>	2 x 10 <sup>-10</sup>
Temperature (0°–55° C)	<1 x 10 <sup>-6</sup>	<3 x 10 <sup>-9</sup>

**Accessories Furnished:** Power cord and operating, programming, and service manuals

**Size:** 88.5 mm H x 213 mm W x 300 mm D (3.54 in x 8.52 in x 12 in)

**Weight:** 4 kg (8.8 lb) without battery option; 6.4 kg (14.08 lb) with battery option

### Ordering Information

**53150A** 20 GHz Microwave Counter

**53151A** 26.5 GHz Microwave Counter

**53152A** 46 GHz Microwave Counter

### Options

**Opt 001** Oven Timebase

**Opt 002** Battery/DC Input

**Opt 007** Soft Carrying Case

**Opt 1BP** MIL-STD-45662 Calibration w/data

**Opt 1CM** Rack Mounting Kit

**Opt W30** 3-Yr. Return Repair Service

**Opt W50** 5-Yr. Return Repair Service

- Three frequency ranges up to 46 GHz
- True power meter with 8480 series sensors
- DVM standard and battery optional
- Fully standard programmable GPIB and RS-232 standard

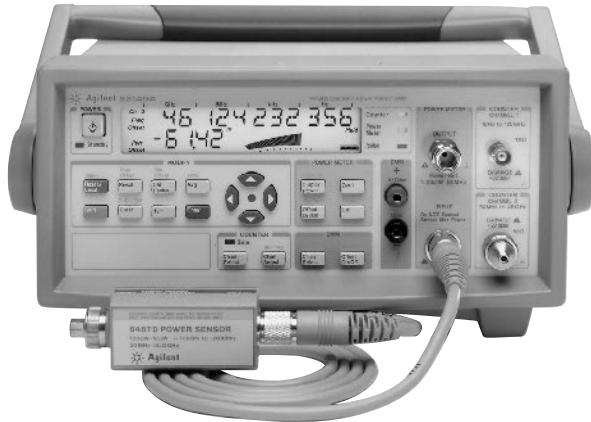

53149A

### 53147A, 53148A, 53149A Microwave Counter/Power Meter/DVMs GPIB

The Agilent 53140 series microwave counter/power meter/dvms have all the fundamental measurements required to install and maintain today's digital microwave radio links. Rugged field portability and a battery option complete the ensemble. These instruments are also at home in ATE applications with GPIB and RS-232 fully programmable I/O ports as standard features. For those demanding R&D application, the 53140 series offer the laboratory-level performance and accuracy you've come to expect from Agilent Technologies.

#### 53140 Series Abridged Measurement

##### Specifications and Characteristics

For full specifications, please call your Agilent representative and request a Product Overview for the 53140 series microwave counters.

#### Counter Specifications

##### Input Characteristics

	Input 1 (1 M $\Omega$ )	Input 2 (50 $\Omega$ )	
<b>Frequency Range</b>			
53147A	10 Hz to 125 MHz	.05-20 GHz	
53148A	10 Hz to 125 MHz	.05-26.5 GHz	
53149A	10 Hz to 125 MHz	.05-46 GHz	
<b>Sensitivity</b>		<b>53147A/48A</b>	<b>53149A</b>
< 30 GHz	40 mVrms	—	—
to 125 MHz	25 mVrms	—	—
< 250GHz	—	-20 dBm	-20 dBm
to 12.4 GHz	—	-33 dBm	-33 dBm
to 18 GHz	—	-33 dBm	-30 dBm
to 20 GHz	—	-29 dBm	-27 dBm
to 26.5 GHz	—	-25 dBm (148)	-27 dBm
to 40 GHz	—	—	-23 dBm
to 46 GHz	—	—	-17 dBm
<b>Damage Level</b>	5 Vrms to 120 Vp	+27 dBm	

##### Channel 1

**Resolution:** Selectable 1 Hz to 1 MHz  
**Low Pass Filter:** 50 kHz, selectable

##### Channel 2

**Resolution:** Selectable 1 Hz to 1 MHz  
**Acquisition Time:** 100 ms to 140 ms  
**Gate Time:** 1/Resolution  
**FM Tolerance:** 20 MHz p-p max. @ 10 MHz rate to 26.5 GHz;  
 12 MHz p-p max. @ 10 MHz rate to 46 GHz  
**Amplitude Discrimination (above 250 MHz):** 20 dB typ. for greater than 75 MHz separation; 10 dB typ. For less than 75 MHz separation  
**Connector:** 3.5 mm SMA compatible (53147A/53148A)  
 2.92 mm removable (53149A)

#### Power Meter Specifications

**Frequency Range:** 10 MHz to 50 GHz, sensor-dependent  
**Power Range:** -70 dBm to +20 dBm, sensor-dependent  
**Power Sensors:** 8480 series  
**Display Units:** Watts, dBm  
**Resolution:** 0.01 dB in log mode, 0.1% of full scale in linear mode  
**Accuracy**  
**Instrumentation:**  $\pm 0.02$  dB or  $\pm 0.5\%$   
**Power Reference**  
**Power Output:** 1.00 mW. Factory set to  $\pm 0.7\%$ , traceable to U.S. National Institute of Standards and Technology.

#### DVM Specifications

**Function:** DC volts  
**Range:**  $\pm 50$  Vdc

#### General

**Display:** Backlit LCD  
**Programming:** GPIB and RS-232C, SCPI compatible  
**Math Functions**  
**Offset:** Last reading and/or entered offset to reading for either power of frequency  
**Averaging:** 1 to 99 measurement running average  
**Save and Recall:** Up to 9 complete instrument setups may be saved and later recalled  
**Power Requirements:**  
 90 – 132 VAC; 50, 60, 400 Hz  
 216 – 264 VAC; 50, 60 Hz  
 11 – 18 VDC: battery option only  
**Battery (option):**  
 Type: VHS camcorder, sealed lead acid (2 each)  
 Charge Time: 8 hours in unit  
 Capacity: 2 hours typical

##### Timebase:

	TXCO (std)	Oven (opt)
Aging Rate	$1 \times 10^{-7}$ /mo	$5 \times 10^{-10}$ /day
Short Term (1 sec. avg.)	$1 \times 10^{-9}$	$2 \times 10^{-10}$
Temperature (0° C–55° C)	$< 1 \times 10^{-6}$	$< 3 \times 10^{-9}$

**Accessories Furnished:** Power cord, 1.5 m power sensor cable (11730A), operating, programming and service manuals

#### Ordering Information

**53147A** 20 GHz Counter/Power Meter/DVM  
**53148A** 26.5 GHz Counter/Power Meter/DVM  
**53149A** 46 GHz Counter/Power Meter/DVM

##### Options

- Opt 001** Oven Timebase
- Opt 002** Battery/DC Input
- Opt 007** Soft Carrying Case

- Frequency extensions to 26.5 GHz, 40 GHz
- Measure frequency (pulsed or CW), PRI, PRF, pulse width, off-time, and frequency profiles directly



5361B

### 5361B Pulse/CW Microwave Counter



The 5361B offers both high-precision pulse and CW performance. With built-in frequency modulation profiling, the 5361B characterizes radar, EW, and communications systems or components. This counter lowers your equipment costs by eliminating the need for a separate CW counter, pulse generator, and computer.

Key features include:

**Pulse measurements:** Frequency, PRF, PRI, pulse width, and off-time.  
**Frequency profiling:** Characterize frequency transients, modulation (such as chirp), and linearity using the PROFILE function. No external gate is required.

**Fast track:** Measure a signal that is sweeping at up to 800 MHz/s.

**Low FM rate:** Measure signals that vary slowly in frequency.

**Simplified operation:** To offload the operator, built-in automatic functions include calibration, signal assessment (pulsed or CW), signal acquisition, gate width calculation and setting, gate positioning, PRF mode, tracking of sweeping signals, pulse averaging for desired resolution and measurement display.

**Scope-View:** Set up externally gated measurements by viewing the downconverted pulse with a dc offset.

The 5361B is a cost-effective choice for manufacturing and service. High-speed throughput saves operator time and lowers cost. Periodic maintenance is limited to time-base calibration.

For radars, VCOs, and DTOs, the 5361B makes frequency, timing, and profiling measurements at the touch of a button. The counter makes more complex measurements for the carrier frequency of agile signals, staggered PRIs, or the frequency transients in a pulsed or CW signal. With one instrument you can characterize radar pulses or test a Stable Local Oscillator (STALO). Functions for measuring step response, post-tuning drift, and settling time facilitate accurate and easy testing of VCOs and DTOs.

### Summary Specifications

#### Input Characteristics

	Input 1 (50 Ω)	Input 2 (1M Ω)	Input 2 (50 Ω)
<b>Frequency range</b>	500 MHz to 20, 26.5, 40 GHz	10 Hz to 80 MHz	10 MHz to 525 MHz
<b>Sensitivity</b>		25 mV rms	25 mV rms
0.5 to 12.4 GHz	-28 dBm		
12.4 to 20 GHz	-23 dBm		
0.5 to 26.5 GHz (Option 026, 040)	-20 dBm		
26.5 to 40 GHz (Option 040)	0.37 x f (in GHz) -29.8 dBm		

#### Frequency (Input 1)

**Automatic and Manual Acquisition:** 500 MHz to 20 GHz; 500 MHz to 26.5 GHz (Option 026); 500 MHz to 40 GHz (Option 040)

**Least Significant Digit:** 1 MHz to 1 Hz for frequency, 0.001 Hz for PRF

#### Pulse Frequency Measurements

**Pulse Width** (minimum): Manual mode, 60 ns; auto mode, 100 ns

**Pulse Rep. Freq.:** Minimum 1 Hz; maximum 2 MHz

**Measurement Time, Resolution, Accuracy:** See data sheet

#### CW Frequency Measurements

**FM Tolerance:** 55 MHz peak-to-peak

**Tracking Speed** (fast acquisition): 800 MHz/s

**Acquisition Time:** Manual mode, <40 ms; automatic mode, fast acq., <100 ms

**Gate Times** (1 Hz resolution): 200 to 1000 ms

**Measurement Time:** ≥ 8.5 ms (in Dump Mode)

**Accuracy:** See data sheet

#### Pulse Parameters (Input 1)

	Pulse width	PRI	Offtime	PRF
<b>Min./Max.</b>	60 ns/10 ms	500 ns/1 s	400 ns/1 s	1 Hz/2 MHz to 0.001 Hz
<b>LSD</b>	(PW <1 ms) 1 ns; (PW ≥1 ms) 100 ns			
<b>Accuracy (100 Avg.)</b>	± (20 ns + timebase uncertainty x measurement ± LSD)			± (20 ns) x (PRF) <sup>2</sup> ± LSD ± timebase uncertainty

#### Profile (Input 1)

**Frequency Range** (min./max. for Y axis): 500 MHz/40 GHz

**FM Chirp Tolerance** (max. span for Y axis): 50 MHz peak-to-peak

**Time Range** (min./max. for span x axis): 100 ns/10 ms

**Time Resolution:** 1 ns

**Internal Gate Width:** Minimum: 11 to 23 ns; typical minimum: 14 ns

**External Gate Width:** Minimum: manual acquisition 20 ns;

auto-acquisition 60 ns

**Number of Data Points:** Up to 100

#### Profile Frequency Measurements

**Printers Supported:** HP 2225A, HP 2227B, HP 3630A Option 002

**Profile Phase Measurements:** See Application Note 377-4, p/n 5952-8023 for details. Computer required.

#### Frequency (Input 2)

**Range:** 10 Hz to 525 MHz

**Accuracy:** 0.001 to 1 Hz

**Resolution / LSD:** 0.001 to 1 Hz

#### Options

**Option 001 Oven Timebase:** Aging rate < 5 x 10<sup>-10</sup> / day

**Option 006, Increased Damage Level:** Pulsed, + 50 dBm (100 W) peak; CW, +39 dBm (8 W)

**Option 010 High-Stability Oven Timebase:** Aging rate < 7 x 10<sup>-10</sup> / week (Standard timebase: Aging rate < 1 x 10<sup>-7</sup> / month)

**Option 026:** Frequency extensions for input 1 to 26.5 GHz

**Option 040:** Frequency extensions for input 1 to 40 GHz

#### Ordering Information

**5361B Pulsed/CW Microwave Counter**

**Opt 001** Oven Timebase

**Opt 006** Microwave Limiter

**Opt 010** High-Stability Timebase

**Opt 026** 26.5 GHz Frequency Extension

**Opt 040** 40 GHz Frequency Extension

**Opt 908** Rackmount Kit for Use with Front Handles Removed

**Opt 910** Additional Operating and Programming Manual

**Opt 913** Rackmount Kit for Use With Supplied Front Handles

**Opt 915** Service Manual

**Opt W30** Extended Repair Service

**Opt W32** Calibration Service





Agilent offers a full line of digital multimeters.

### Find Your Fit in the Agilent Family

From a bench top to a test rack to a VXibus system, there's an Agilent digital multimeter (DMM) that's right for the job:

#### 3458A Multimeter

Up to 8½ digits and up to 100,000 readings per second. Test engineers, R&D engineers, and metrologists worldwide rely on its accuracy and speed.

#### 34420A Nanovolt/Micro-ohmeter

With 7½ digits of resolution, 8 nVpp noise, and built-in resistance and SPRT functions, the 34420A can handle your most demanding low-level measurements.

#### 34401A Multimeter

The world's best-selling benchtop/system DMM delivers 6½-digit performance at a 5½-digit DMM price.

#### VXibus DMMs

Five B- and C-size multimeters to choose from. Perfect for data acquisition and computer-aided test applications. Refer to the VXibus section of this catalog for more information.

### Digital Multimeters/Digital Voltmeters

	34401A	34420A	3458A	E1412A VXibus DMMs
<b>Digits</b>	6½	7½	8½	6½
<b>DC voltage</b>				
Basic 1 yr. accuracy	35 ppm	30 ppm	8 ppm (4 ppm opt.)	35 ppm
Sensitivity	100 nV	0.1 nV	10 nV	100 nV
Maximum reading rate	1,000 rdg/s	250 rdg/s	100,000 rdg/s	1,000 rdg/s
Maximum range	1,000 V	100 V	1,000 V	300 V
<b>Resistance</b>				
Basic 1 yr. accuracy	0.01%	0.006%	0.001%	0.01%
Sensitivity	100 µΩ	0.1 µΩ	10 µΩ	100 µΩ
<b>AC voltage</b>				
Basic 1 yr. accuracy	0.06%	NA	0.014%	0.06%
Bandwidth	3 Hz to 300 kHz	NA	1 Hz to 10 MHz	3 Hz to 300 kHz
<b>Functions</b>	dc and ac V dc and ac I 2- and 4-wire Ω Diode test Frequency Period Continuity Reading hold dB, dBm Null, min/max, pass/fail, ratio 512 reading storage GPIB, RS-232	dc V 2-channel voltage input 2- and 4-wire Ω Offset-compensated Ω Low power Ω Voltage clamped Ω Temperature (including SPRT) Analog and digital filter Chart recorder analog output 1,024 reading storage GPIB, RS-232	dc and ac V dc and ac I 2- and 4-wire Ω Offset-compensated Ω Frequency Period Math Ratio Internal Basic 20 KB reading memory Digitizing GPIB	dc and ac V dc and ac I 2- and 4-wire Ω Frequency Period Temperature dB, dBm Null, limit, min/max 1000 reading storage
<b>More information in this catalog</b>	page 146	page 148	page 150	page 93 VXibus products

# Digital Multimeters

146

## Low-Cost 6½ Digit Multimeter

34401A

- 12 measurement functions
- 1000 V maximum input
- 15 ppm basic dcV accuracy (24-hour)
- 1000 readings per second direct to GPIB
- GPIB and RS-232 standard
- 512-reading memory
- SCPI commands standard

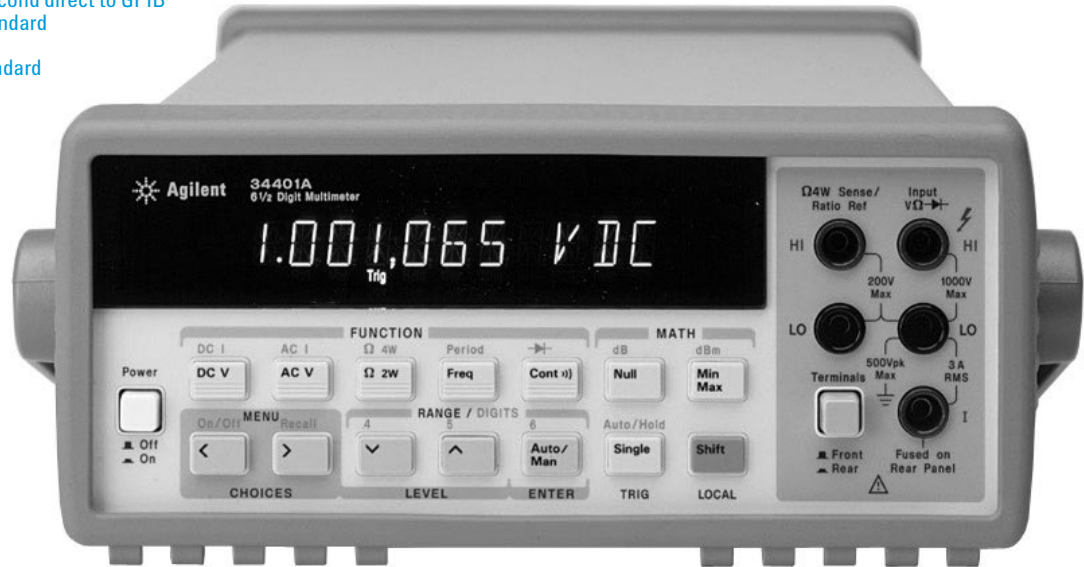

4

34401A

### 34401A Digital Multimeter



The 34401A digital multimeter establishes a new price/performance standard by offering such features as 6½ digits of resolution, 1000 readings per second, and 15 ppm basic dc accuracy at a surprisingly affordable price. The 34401A has been designed for superior performance while providing the flexibility to meet both your present and future needs.

#### Great Bench Performance

The clear, logical front panel of the 34401A allows you to easily select all primary measurement functions. Traditional "bench" functions, such as continuity and diode test, are included. Math functions, such as NULL, dB, dBm, limit test, and min/max/avg are easily selected. A simple menu scheme gives you access to powerful advanced features, such as the ability to store up to 512 readings in internal memory. Measurement results are displayed on a bright, high-visibility readout. A rugged case ensures survival even under the toughest conditions, and the optional accessory pouch makes it easy to pack up and go with the 34401A.

#### Superior Performance in Your System

The 34401A can take up to 1000 readings per second, including GPIB bus transfer in ASCII format. Both GPIB and RS-232 are standard, letting you select the interface that best meets your needs. The 34401A responds to three different command languages. It accepts SCPI commands (Standard Commands for Programmable Instruments), which ensures present and future compatibility. It also responds to commands for the HP 3478A and the Fluke 8840A, thereby protecting your software investment with backward compatibility. Drivers are also available for both National Instruments Labview and Agilent's VEE software.

### Abbreviated Technical Specifications

#### DC Voltage

##### Input Characteristics

Range	Maximum reading (6½ digits)	Resolution in digits			Input resistance
		6½	5½	4½	
100 mV	120.0000	100 nV	1 µV	10 µV	10 MΩ or > 10 GΩ
1 V	1.200000	1 µV	10 µV	100 µV	10 MΩ or > 10 GΩ
10 V	12.00000	10 µV	100 µV	1 mV	10 MΩ or > 10 GΩ
100 V	120.0000	100 µV	1 mV	10 mV	10 MΩ
1000 V	1050.000	1 mV	10 mV	100 mV	10 MΩ

**Input Protection:** >1000 V on all ranges

**Measurement Accuracy:** ±(% of reading + % of range)

Range	24-Hour 23° C ±1° C	90-Day 23° C ±5° C	1-Year 23° C ±5° C
100 mV	0.0030 + 0.0030	0.0040 + 0.0035	0.0050 + 0.0035
1 V	0.0020 + 0.0006	0.0030 + 0.0007	0.0040 + 0.0007
10 V	0.0015 + 0.0004	0.0020 + 0.0005	0.0035 + 0.0005
100 V	0.0020 + 0.0006	0.0035 + 0.0006	0.0045 + 0.0006
1000 V	0.0020 + 0.0006	0.0035 + 0.0010	0.0045 + 0.0010

**Noise Rejection:** (50 or 60 Hz, 1 kΩ unbalance in LO lead)

**DC CMRR:** 140 dB

**AC CMRR:** 70 dB

**Normal mode rejection** (60 Hz/50 Hz) ± 0.1%:

- 100 PLC (1.67 s/2.00 s): 60 dB
- 10 PLC (167 ms/200 ms): 60 dB
- 1 PLC (16.7 ms/20.0 ms): 60 dB
- <1 PLC (3 ms or 800 µs): 0 dB

**Maximum Reading Rate:** (readings/s)

Power line frequency	Resolution in digits		
	6½	5½	4½
60 Hz	6	300	1000
50 Hz	5	300	1000

#### AC Voltage (true rms)

**Measurement Accuracy:** ± (% of reading + % of range); 1 year, 23° C ± 5° C

Frequency	Ranges	Ranges
	100 mV	1, 10, 100, 750 V
3 to 5 Hz	1.00 + 0.04	1.00 + 0.03
5 to 10 Hz	0.35 + 0.04	0.35 + 0.03
10 Hz to 20 kHz	0.06 + 0.04	0.06 + 0.03
20 to 50 kHz	0.12 + 0.04	0.12 + 0.05
50 to 100 kHz	0.60 + 0.08	0.60 + 0.08
100 to 300 kHz	4.00 + 0.50	4.00 + 0.50

Note: -3 dB frequency typically >1 MHz

**Input Resistance:** 1 MΩ ±2%, in parallel with 100 pF

**Input Protection:** >750 V rms on all ranges

**Maximum Volt-Hz Product:** 8 × 10<sup>7</sup>

**Crest Factor:** Maximum of 5:1 at full scale

**Maximum Reading Rate:** 10 readings/s (50 readings/s with default delays defeated)

#### Frequency and Period

**Range:** 3 Hz to 300 kHz (333 ms to 3.33 µs)

**1-Year Accuracy:** 0.01% (40 Hz to 300 kHz); 0.05% (3 to 40 Hz)

**Resolution:** 10 µHz to 1 Hz

**Other Measurement Functions:** Continuity, Diode Test, Ratio dc:dc, Limit Test

**Math Functions:** NULL, Min/Max/Avg, dB, dBm, Limit Test

**Memory:** 512-reading internal storage

**Standard Programming Languages:** SCPI, HP 3478A and Fluke 8840A/42A

**Computer Interface:** GPIB and RS-232C standard

**Accessories Included:** Test lead kit, operators manual, service manual, test report, and power cord

**Warranty:** 3 years standard

**Resistance:** (2-wire Ω, 4-wire Ω)

#### Input Characteristics

Range	Maximum reading (6½ digits)	Resolution in digits		
		6½	5½	4½
100 Ω	120.0000	100 µΩ	1 mΩ	10 mΩ
1 kΩ	1.200000	1 mΩ	10 mΩ	100 mΩ
10 kΩ	12.00000	10 mΩ	100 mΩ	1 Ω
100 kΩ	120.0000	100 mΩ	1 Ω	10 Ω
1 MΩ	1.200000	1 Ω	10 Ω	100 Ω
10 MΩ	12.00000	10 Ω	100 Ω	1 kΩ
100 MΩ	120.0000	100 Ω	1 kΩ	10 kΩ

**Input Protection:** >1000 V on all ranges

**Measurement Accuracy:** ±(% of reading + % of range)

Specs are for 4-wire Ω or 2-wire Ω using Math Null

Range	24-Hour 23° C ±1° C	90-Day 23° C ±5° C	1-Year 23° C ±5° C	Current source
100 Ω	0.0030 + 0.0030	0.008 + 0.004	0.010 + 0.004	1 mA
1 kΩ	0.0020 + 0.0005	0.008 + 0.001	0.010 + 0.001	1 mA
10 kΩ	0.0020 + 0.0005	0.008 + 0.001	0.010 + 0.001	100 µA
100 kΩ	0.0020 + 0.0005	0.008 + 0.001	0.010 + 0.001	10 µA
1 MΩ	0.0020 + 0.001	0.008 + 0.001	0.010 + 0.001	5.0 µA
10 MΩ	0.0150 + 0.001	0.020 + 0.001	0.040 + 0.001	500 nA
100 MΩ	0.3000 + 0.010	0.800 + 0.010	0.800 + 0.010	500 nA*

\* Measurement is computed from 10 MΩ in parallel with input.

**Maximum Reading Rate:** Same as dcV

#### DC Current

**Measurement Accuracy:** ±(% of reading + % of range)

Range	24-Hour 23° C ±1° C	90-Day 23° C ±5° C	1-Year 23° C ±5° C	Shunt resistance
10 mA	0.005 + 0.010	0.030 + 0.020	0.050 + 0.020	5.0 Ω
100 mA	0.010 + 0.004	0.030 + 0.005	0.050 + 0.005	5.0 Ω
1 A	0.050 + 0.006	0.080 + 0.010	0.100 + 0.010	0.1 Ω
3 A	0.100 + 0.020	0.120 + 0.020	0.120 + 0.020	0.1 Ω

**Burden Voltage:** <2 V for 3 A input; <0.1 V for 10 mA input

**Input Protection:** Externally accessible 3 A 250 V fuse; internal 7 A 500 V fuse

**Maximum Reading Rate:** Same as dcV

#### AC Current (true rms)

**Measurement Accuracy:** ±(% of reading + % of range); 1 year, 23° C ± 5° C

Frequency	Ranges	Ranges
	1 A	3 A
3 to 5 Hz	1.00 + 0.04	1.10 + 0.06
5 to 10 Hz	0.30 + 0.04	0.35 + 0.06
10 Hz to 5 kHz	0.10 + 0.04	0.15 + 0.06

**Burden Voltage:** <1.5 V rms for 3 A input

**Input Protection:** Externally accessible 3 A 250 V fuse; internal 7 A 500 V fuse

**Maximum Reading Rate:** Same as acV

### General Specifications

**Power:** 100/120/220/240V, ±10%

**Power Line Frequency:** 45 to 66 Hz, 360 to 440 Hz

**Power Consumption:** 25 VA peak (10 W average)

**Operating Environment:** 0° to 55° C, full accuracy to 80% RH, 40° C

**Storage Environment:** -40° C to 75° C

**Size:** 88.5 mm H x 212.6 mm W x 348.3 mm D (4 in x 8.5 in x 14 in)

**Weight:** Net, 3.6 kg (8.0 lb); shipping, 5.9 kg (13 lb)

**Safety:** Designed to UL-1244, IEC-348, CSA

### Ordering Information

**34401A** Multimeter

**Opt 908** Rackmount Kit

**Opt 1BP** MIL-STD-45662A Certificate of Calibration with Data

**34397A** DC to AC Power Inverter

**HP 34812A** BenchLink/Meter Software

**34161A** Accessory Pouch

**34171A** Input Terminal Connector (sold in pairs)

**34172A** Input Calibration Short (sold in pairs)

 Indicates QuickShip availability.

34420A

- 1.3 nV rms noise/8 nVp-p
- 100 pV, 100 nΩ sensitivity
- Two-channel programmable voltage input; difference and ratio functions
- 7½ digit resolution
- 1 mV to 100 V ranges
- SCPI and Keithley 181 languages
- Direct SPRT, RTD, Thermistor, and thermocouple temperature measurements



34420A

### 34420A Nanovolt / Micro-ohm Meter



The Agilent 34420A sets a price/performance standard in low-level measurement capability. The noise performance of the 34420A nanovolt/micro-ohm meter is more than an order of magnitude better than that previously available from Hewlett-Packard.

#### Accurate, Repeatable Low-Level Measurements

A shielded copper pin screw-down connector, a 7½-digit A/D converter, 2 ppm basic dc accuracy, and a new measurement algorithm that gives 100 dB normal mode rejection without front-end filtering result in measurement capability you can depend on to make accurate and repeatable low-level measurements. Low noise input amplifiers and a highly-tuned input protection scheme bring reading noise down to 8 nVp-p. Longer integration times improve noise performance even further.

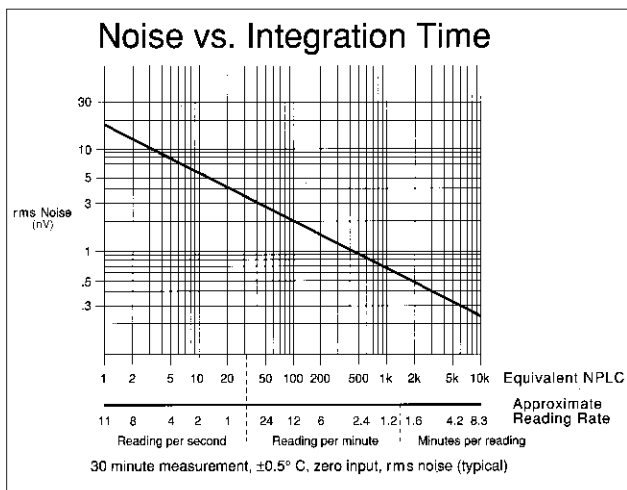

#### Unprecedented Functionality

Two input channels allow voltage measurements to be made independently, or they can be mathematically combined to make difference and ratio measurements. Ohms measurements combine the low-noise input circuits with a highly-stable current source to provide outstanding low-resistance measurements. Offset compensation is employed to eliminate the effects of stray thermal EMFs that would otherwise result in measurement error. Low power ohms and a low-voltage resistance measurement capability allow repeatable measurements to be made where a low voltage (20 mV) is required to avoid oxidation punch-through. A wide range of temperature measurement capabilities are also built in, providing support for SPRT, thermocouple, RTD, and thermistor temperature sensors.

#### Math Functions Enhance Capabilities

Math functions such as NULL, STATS, and SCALE ease the capture of minimum and maximum readings, provide averages and standard deviation, scale your measurement results, and ultimately makes it easier for you to characterize your input signal. The 34420A can also store up to 1024 readings in internal memory.

#### Built-in Versatility

You will find that the 34420A will fit equally well into your bench or your system applications. Designed with the bench user in mind, operation of the 34420A from the front panel is straightforward and intuitive. For system applications, the 34420A includes both GPIB and RS-232 interfaces standard, and uses Standard Commands for Programmable Instrumentation (SCPI). This ensures both present and future compatibility. The 34420A also responds to commands for the Keithley 181 nanovoltmeter.



### Abbreviated Technical Specifications

**Accuracy Specifications:** ± (% of reading + % of range)

#### DC Voltage<sup>1</sup> – 7½ digits resolution all ranges

Range	24-Hour 23°C ±1°C	90-Day 23°C ±5°C	1-Year 23°C ±5°C
1 mV	0.0025 + .0020	0.0040 + .0020	0.0050 + .0020
10 mV	0.0025 + .0002	0.0040 + .0002	0.0050 + .0003
100 mV	0.0015 + .0003	0.0030 + .0004	0.0040 + .0004
1 V	0.0010 + .0003	0.0025 + .0004	0.0035 + .0004
10 V	0.0002 + .0001	0.0020 + .0004	0.0030 + .0004
100 V	0.0010 + .0004	0.0025 + .0005	0.0035 + .0005

**DCV1/DCV2 (ratio):** Ratio error in % = channel 1 accuracy in % + channel 2 accuracy in %

**DCV1-2 (difference):** Difference error = channel 1 (% reading + % range) + channel 2 (% reading + % range)

#### DC Voltage Noise Specifications<sup>2</sup>

Range	2-Minute rms noise	2-Minute p-p noise	24-Hour p-p noise
1 mV	1.3 nV RMS	8 nV p-p	12 nV p-p
10 mV	1.5 nV RMS	10 nV p-p	14 nV p-p
100 mV	10 nV RMS	65 nV p-p	80 nV p-p
1 V	100 nV RMS	650 nV p-p	800 nV p-p
10 V	450 nV RMS	3 μV p-p	3.7 μV p-p
100 V	11 μV RMS	75 μV p-p	90 μV p-p

#### DC Voltage

##### Input Resistance:

10 MΩ ±1% (100 V range)

>10 GΩ (1 mV through 10 V range)

##### Input Protection:

150 V peak to Channel 1 LO

#### Resistance<sup>3</sup> – 7½ digits resolution all ranges

Range	Test current	24-Hour 23°C ±1°C	90-Day 23°C ±5°C	1-Year 23°C ±5°C
1Ω	10 mA	0.0015 + .0002	0.0050 + .0002	0.0070 + .0002
10 Ω	10 mA	0.0015 + .0002	0.0040 + .0002	0.0060 + .0002
100 Ω	10 mA	0.0015 + .0002	0.0040 + .0002	0.0060 + .0002
1 kΩ	1 mA	0.0015 + .0002	0.0040 + .0002	0.0060 + .0002
10 kΩ	100 μA	0.0015 + .0002	0.0040 + .0002	0.0060 + .0002
100 kΩ	10 μA	0.0015 + .0003	0.0040 + .0004	0.0060 + .0004
1 MΩ	5 μA	0.0020 + .0003	0.0050 + .0004	0.0070 + .0004

#### Low Power Resistance<sup>3</sup>

Range	Test current	24-Hour 23°C ±1°C	90-Day 23°C ±5°C	1-Year 23°C ±5°C
1 Ω	10 mA	0.0015 + .0002	0.0050 + .0002	0.0070 + .0002
10 Ω	10 mA	0.0015 + .0002	0.0040 + .0002	0.0060 + .0002
100 Ω	1 mA	0.0015 + .0002	0.0040 + .0002	0.0060 + .0002
1 kΩ	100 μA	0.0015 + .0002	0.0040 + .0002	0.0060 + .0002
10 kΩ	10 μA	0.0015 + .0004	0.0040 + .0004	0.0060 + .0004
100 kΩ	5 μA	0.0015 + .0012	0.0040 + .0015	0.0060 + .0015
1 MΩ	5 μA	0.0020 + .0003	0.0050 + .0004	0.0070 + .0004

#### Voltage Limited Resistance<sup>3</sup>

Voltage limit selectable: 20 mV, 100 mV, or 500 mV

Range	Test current	24-Hour 23°C ±1°C	90-Day 23°C ±5°C	1-Year 23°C ±5°C
10 Ω	1 mA	0.0020 + .0002	0.0050 + .0002	0.0070 + .0002
100 Ω	100 μA	0.0025 + .0002	0.0050 + .0002	0.0070 + .0002

#### Temperature – 0.001°C Resolution

Probe type	Accuracy
SPRT <sup>4</sup>	SPRT probe accuracy + 0.003°C
RTD	RTD probe accuracy + 0.05°C
Thermistor	Thermistor probe accuracy + 0.1°C
Thermocouple <sup>5</sup>	Thermocouple probe accuracy + 0.2°C

#### Temperature

**SPRT:** ITS-90 calibrated temperature within the range of –190°C to +660°C  
**RTD:** Type α = .00385 and α = .00392. R<sub>0</sub> from 4.9 Ω to 2.1 kΩ. ITS-90 (IEC 751) Callendar - Van Dusen conversion.

**Thermistor:** 5 KΩ

**Thermocouple:** ITS-90 conversions of type B, E, J, K, N, R, S, T

**Chart Out (Analog Out)**

**Resolution:** 16 bits

**Maximum Output:** ±3 V

**Span and Offset:** Adjustable

**Filter (Analog or Digital or Both)**

**Analog:** Low pass 2 pole @ 13 Hz, available for dcV on 1 mV, 10 mV, 100 mV ranges

**Digital:** Moving average filter. 10 (fast), 50 (medium) or 100 (slow) reading averages.

#### Math Functions

**NULL (Channel 1 dcV, Channel 2 dcV, Difference, Resistance, Temperature)**

**STATS (Min/max/avg, peak-peak, standard deviation, number of readings)**

**SCALE (Allows linear scaling as Y=MX + B)**

**CHART NULL (Establishes zero for rear-panel output)**

### General Specifications

**Front-Panel Connection:** Shielded, low-thermal, copper contacts

**Interface:** GPIB and RS-232 standard

**Languages:** SCPI-1994 (IEEE-488.2), Keithley 181

**Warranty:** 3 years standard

### Ordering Information

#### 34420A Nanovolt/Micro-Ohm Meter

Includes low-thermal input cable (34102A), low-thermal shorting plug (34103A), operating and service manuals, quick reference guide, test report with calibration sticker, 2.3 ml bottle of contact cleaner, and power cord.

#### Opt 1CM Rackmount Kit

#### Accessories

**34102A Low-Thermal Input Cable (four-conductor with copper spade lugs)**

**34103A Low-Thermal Shorting Plug**

**34104A Low-Thermal Input Connector**

**34161A Accessory Pouch**

<sup>1</sup> Specifications are for channel 1 or channel 2 (100 V range on channel 1 only), after 2-hour warm-up, resolution at 7.5 digits (100 NPLC), with filters off.

<sup>2</sup> After a 2-hour warm-up ± 1°C, 6.5 digits (10 NPLC) with analog filter off digital filter medium (50 readings), 2 minute rms and 24-hour noise typical.

<sup>3</sup> All resistance specifications are for channel 1 only, after 2-hour warm-up, resolution at 7.5 digits (100 NPLC) with filters off, for 4-wire Ω or 2-wire Ω using Null.

<sup>4</sup> For 25 Ω SPRT with triple-point of water check within last 4 hours. With no triple-point of water check, add 0.013°C for 24-hour, 0.035°C for 90-day, and 0.055°C for 1-year specifications.

<sup>5</sup> For fixed reference junction. Add 0.3°C for external reference junction, add 2.0°C for internal reference junction.

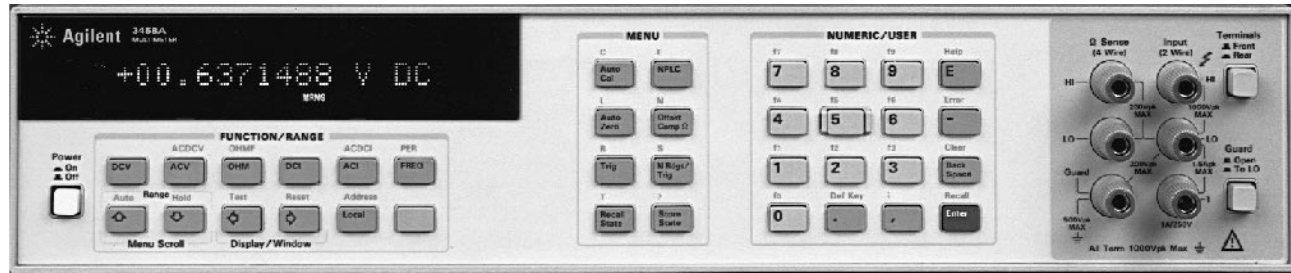

3458A

### 3458A Multimeter



The Agilent 3458A multimeter shatters long-standing performance barriers of speed and accuracy on the production test floor, in research and development, and in the calibration lab. The 3458A is the fastest, most flexible, and most accurate multimeter offered by Agilent Technologies. In your system or on the bench, the 3458A saves you time and money with unprecedented test-system throughput and accuracy, seven-function measurement flexibility, and low cost of ownership.

Select a rate of 100,000 reading per second for maximal test throughput. Or achieve highest levels of precision with up to 8½ digits of measurement resolution and 0.1 part per million transfer accuracy. Add to this the 3458A's simplicity of operation, and you have the ideal multimeter for your most demanding applications.

### High-Test System Throughput

#### Faster Testing

- Up to 100,000 readings/s
- Internal test setups > 340/s
- Programmable integration times from 500 ns to 1 s

#### Greater Test Yield

- More accuracy for tighter test margins
- Up to 8½ digits resolution

#### Longer Uptime

- Two-source (10 V, 10 kΩ) calibration, including ac
- Self-adjusting, self-verifying auto-calibration for all functions and ranges, including ac

### High-Resolution Digitizing

#### Greater Waveform Resolution and Accuracy

- 16 to 24-bits resolution
- 100,000 to 0.2 sample/s
- 12 MHz bandwidth
- Timing resolution to 10 ns
- Less than 100 ps time jitter
- Over 75,000 reading internal memory

### Calibration Lab Precision

#### Superb Transfer Measurements

- 8½ digits resolution
- 0.1 ppm dc volts linearity
- 0.1 ppm dc volts transfer capability
- 0.01 ppm rms internal noise

#### Extraordinary Accuracy

- 0.6 ppm for 24 hours in dc volts
- 2.2 ppm for 24 hours in Ω
- 100 ppm mid-band ac volts
- 8 ppm (4 ppm optional) per year voltage reference stability

### 3458A Multimeter Performance Features

#### DC Volts

- 5 ranges: 0.1 V to 1000 V
- 8½ to 4½ digits resolution
- Up to 100,000 readings/s (4½ digits)
- Maximum sensitivity: 10 nV
- 0.6 ppm 24-hour accuracy
- 8 ppm (4 ppm optional)/year voltage reference stability

#### Resistance

- 9 ranges: 10 Ω to 1 GΩ
- 2-wire and 4-wire Ω with offset compensation
- Up to 50,000 readings/second (5½ digits)
- Maximum sensitivity: 10 μΩ
- 2.2 ppm 24-hour accuracy

#### AC Volts

- 6 ranges: 10 mV to 1000 V
- 1 Hz to 10 MHz bandwidth
- Up to 50 readings/s with all readings to specified accuracy
- Choice of sampling or analog true rms techniques
- 100 ppm best accuracy

#### DC Current

- 8 ranges: 100 nA to 1 A
- Up to 1,350 readings/s (5½ digits)
- Maximum sensitivity: 1 pA
- 14 ppm 24-hour accuracy

#### AC Current

- 5 ranges: 100 μA to 1 A
- 10 Hz to 100 kHz bandwidth
- Up to 50 readings/second
- 500 ppm 24-hour accuracy

#### Frequency and Period

- Voltage or current ranges
- Frequency: 1 Hz to 10 MHz
- Period: 100 ns to 1 second
- 0.01% accuracy
- AC or dc coupled

### Throughput

#### Maximum Reading Rates

- 100,000 readings/s at 4½ digits (16 bits)
- 50,000 readings/s at 5½ digits
- 6,000 readings/s at 6½ digits
- 60 readings/s at 7½ digits
- 6 readings/s at 8½ digits

#### Measurement System Speed

- 100,000 readings/s over GPIB or with internal memory
- 110 autoranges/s
- 340 function or range changes/s
- Postprocessed math from internal memory

### Abbreviated Technical Specifications

#### DC Voltage

Range	Full scale	Maximum resolution	1-Year* accuracy	Transfer accuracy 10 min., tref ±0.5° C	Input impedance
<b>ppm of reading + ppm of range</b>					
100 mV	120.00000	10 nV	9(5) + 3	0.5 + 0.5	>10 GΩ
1 V	1.2000000	10 nV	8(4) + 0.3	0.3 + 0.1	>10 GΩ
10 V	12.0000000	100 nV	8(4) + 0.05	0.05 + 0.05	>10 GΩ
100 V	120.000000	1 μV	10(6) + 0.3	0.5 + 0.1	10 MΩ ±1%
1000 V	1050.00000	10 μV	10(6) + 0.1	1.5 + 0.05	10 MΩ ±1%

One-year specifications for NPLC 100 within 24 hours and ±1° C of last ACAL, Tcal ±5° C, MATH NULL, fixed range. Add 2 ppm of reading additional error for Agilent factory traceability of 10 V dc to US NIST. Traceability error is the absolute error relative to National Standards associated with the source of last external calibration. Transfer specifications for NPLC 100, following 4-hour warm-up. Full scale to 10% of full scale. Measurements on the 1000 V range are within 5% of the initial measurement value and following measurement settling. Tref is the starting ambient temperature. Measurements are made on a fixed range using accepted metrology practices.\* High stability (Option 002) ppm of reading in parentheses.

#### Noise Rejection (dB)<sup>1</sup>

	AC NMR <sup>2</sup>	AC ECRM	DC ECRM
NPLC < 1	0	90	140
NPLC ≥ 1	60	150	140
NPLC ≥ 10	60	150	140
NPLC ≥ 100	60	160	140
NPLC = 1000	75	170	140

<sup>1</sup>Applies for 1 kΩ unbalance in the LO lead and ±0.1% of the line frequency currently set for LFREQ.

<sup>2</sup>For line frequency ±1%, ACNMR is 40 dB for NPLC ≥ 1, or 55 dB for NPLC ≥ 100. For line frequency ±5%, ACNMR is 30 dB for NPLC ≥ 100.

#### Maximum Input

	Rated input	Nondestructive
HI to LO	±1000 V pk	±1200 V pk
LO to guard	±200 V pk	±350 V pk
Guard to earth	±500 V pk	±1000 V pk
HI or LO to earth	±1000 V pk	±1200 V pk

#### True rms AC Voltage

(Synchronous Subsampled Mode)

Range	Full scale	Maximum resolution	Accuracy* 24 hour–2 year 40 Hz to 1 kHz % of reading + % of range	Input impedance
10 mV	12.00000	10 nV	0.02 + 0.011	1 MΩ ±15% with <140 pf
100 mV	120.00000	10 nV	0.007 + 0.002	1 MΩ ±15% with <140 pf
1 V	1.2000000	100 nV	0.007 + 0.002	1 MΩ ±15% with <140 pf
10 V	12.0000000	1 μV	0.007 + 0.002	1 MΩ ±2% with <140 pf
100 V	120.00000	10 μV	0.02 + 0.002	1 MΩ ±2% with <140 pf
1000 V	700.0000	100 μV	0.04 + 0.002	1 MΩ ±2% with <140 pf

\*Specifications apply for full scale to 10% of full scale, dc <10% of ac, sine-wave input, crest factor of 1.4. Within 24 hours and ±1° C of last ACAL. Peak (ac+dc) input limited to 5 x full scale for all ranges. Add 2 ppm of reading additional error for Agilent factory traceability of 10 Vdc to US NIST.

#### Maximum Input

	Rated input	Nondestructive
HI to LO	±1000 V pk	±1200 V pk
LO to guard	±200 V pk	±350 V pk
Guard to earth	±500 V pk	±1000 V pk
HI or LO to earth	±1000 V pk	±1200 V pk
Volt-Hz product	1 x 10 <sup>8</sup>	—

#### Resistance

Range	Full scale	Maximum resolution	Current through unknown	1-Year Accuracy* (4-wire Ω) ppm of rdg+ppm of range
10 Ω	12.00000	10 μΩ	10 mA	15 + 5
100 Ω	120.00000	10 μΩ	1 mA	12 + 5
1 kΩ	1.2000000	100 μΩ	1 mA	10 + 0.5
10 kΩ	12.000000	1 mΩ	100 μA	10 + 0.5
100 kΩ	120.00000	10 mΩ	50 μA	10 + 0.5
1 MΩ	1.2000000	100 mΩ	5 μA	15 + 2
10 MΩ	12.000000	1 Ω	500 nA	50 + 10
100 MΩ	120.00000	10 Ω	500 nA	500 + 10
1 GΩ	1.2000000	100 Ω	500 nA	0.5% + 10

\*Specifications for 100 NPLC, offset compensation on, within 24 hours and ±1° C of last ACAL, Tcal ±5° C. Add 3 ppm of reading additional error for Agilent factory traceability of 10 kΩ to US NIST.

#### Memory

	Standard Readings	Bytes	Option 001 Readings	Bytes
Reading storage (16 bit)	10,240	20 k	+65,536	+128 k
Non-volatile, for subprograms and/or state storage	—	14 k	—	—

#### Math Functions

The 3458A performs the following math functions on measurements: NULL, SCALE, OFFSET, RMS FILTER, SINGLE POLE FILTER, THERMISTOR LINEARIZATION, DB, DBM, % ERROR, PASS/FAIL LIMIT TESTING, and STATISTICS. Two math functions may be used at one time.

### General Specifications

**Operating Temperature:** 0° C to 55° C

**Warmup Time:** Four hours to all specifications except where noted

**Humidity Range:** 95% RH, 0° C to 40° C

**Storage Temperature:** –40° C to +75° C

**Power:** 100/120 V, 220/240 V ±10%, 48 to 66 Hz, 360 to 420 Hz automatically sensed. Fused at 1.5 A @ 115 V or 0.5 A @ 230 V. <30 W, <80 VA (peak).

**Size:** 88.9 mm H x 425.5 mm W x 502.9 mm D (3.5 in x 16.75 in x 19.8 in)

**Weight:** Net, 12 kg (26.5 lb); shipping, 14.8 kg (32.5 lb)

### Ordering Information

**3458A** Multimeter (with GPIB, 20 KB reading memory, and 8 ppm stability)

**Opt 001** Extended Reading Memory (expands total to 148 KB)

**Opt 002** High-Stability (4 ppm/year) Reference

**Opt 1BP** MIL-STD-45662A Certificate of Calibration with Data

**Opt W30** Two Additional Years Return-to-Agilent Hardware Support

**Opt W32** Three-year Customer Return Calibration Coverage

**Opt 907** Front-handle Kit

**Opt 908** Rack Flange Kit

**Opt 909** Rack Flange Kit (with handles)

## Digital Multimeter Accessory Compatibility Chart and Products

Accessory	34401A	3458A	34420A <sup>1</sup>
<b>34132A</b> Deluxe Test Lead Kit	Yes	No	No
<b>34132B</b> Deluxe Test Lead Kit	Yes	Yes	No
<b>11059A</b> Kelvin Probe Set	Yes	Yes	No
<b>11062A</b> Kelvin Clip Set	Yes	Yes	Yes
<b>34133A</b> Precision Electronic Probe	Yes	No	No
<b>11060A</b> Surface-Mount Device Probe	Yes	Yes	No
<b>34171A</b> DMM Terminal Connector	Yes	No	No
<b>34172A</b> DMM Calibration Short	Yes	No	No
<b>11053A</b> Lug-Lug Jumper Set	No	Yes	No
<b>11174A</b> Lug-Banana Jumper Set	Yes	Yes	No
<b>11058A</b> Banana-Banana Jumper Set	Yes	Yes	No
<b>E2307A</b> Type-K Thermocouple Bead Temperature Probe	Yes <sup>2</sup>	No <sup>2</sup>	No
<b>E2308A</b> Thermistor Temp Probe	Yes <sup>2</sup>	Yes	No
<b>40653B</b> Thermistor Surface Sensor Assembly	Yes <sup>2</sup>	Yes	No
<b>34134A</b> AC/DC Current Probe	Yes	No	No
<b>34135A</b> AC/DC Current Probe	Yes	No	No
<b>34330A</b> 30 A Current Shunt	Yes	Yes	No
<b>34397A</b> 12 Vdc to 115V ac inverter	Yes	Yes	Yes
<b>34131A</b> Basic Instrument Transit Case	Yes	No	Yes
<b>34161A</b> Accessory Pouch	Yes	No	Yes

<sup>1</sup>Many accessories are listed as incompatible with 34420A because of the specialized termination. Many of these accessories may be rewired onto the low thermal input connector 34104A.

<sup>2</sup>Need 34812A BenchLink Meter or an external program to do temperature measurements.  
<sup>3</sup>Compatible with voltmeter inputs, however an external program would be needed for temperature calculations.



34132A



34133A



11060A

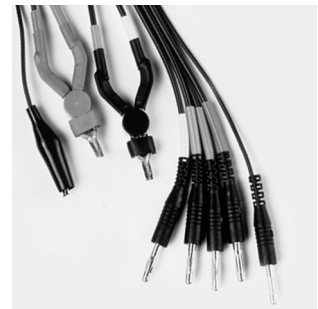

11059A

### Test Leads

#### 34132A/B Deluxe Test Lead Kits

The test leads in these kits feature a 1.4 m flexible cable and a soft Sanoprene over mold for a comfortable grip. They are rated at 1000V CAT III. Each kit contains red and black test leads, needle point and alligator test lead tips, and red and black retractable hook test leads. Supplied in a reusable nylon pouch. The kits are available with the following banana plug configurations:

Model	Description
<b>34132A</b>	Deluxe test lead kit with straight fixed sheath banana plugs
<b>34132B</b>	Deluxe test lead kit with straight retractable sheath banana plugs

#### 34133A Precision Electronic Test Leads

These precision electronic test leads are designed specifically for working with small components and in dense circuit boards. The test leads are small and light. The spring-loaded tip helps absorb those small movements and the crown point digs into solder. The test leads have a 1.2 m flexible cable, terminated in right angle shrouded banana plugs and have a Sanoprene over-mold for a comfortable grip. Each kit includes one black and one red test lead.

#### 11060A Surface Mount Device Tweezers

The gold plated beryllium copper tweezer design provides an easy method to access and accurately measure SMD resistive networks. Length 1.2 m.

### Kelvin Probe and Clips

#### 11059A Kelvin Probe Set

This high quality Kelvin probe set is complete and ready to use for making 4-wire Ohm measurements. The 4 color coded banana jacks and Kelvin clips are both gold plated for maximum conductivity and resistance to corrosion. The probe assembly also includes a ground to guard connector to help remove any ground related errors for the ultimate in high accuracy measurement, ideal for use with the 3458A 8½ digit DMM. The wires are encased in a woven shroud for ease of use and to protect the cables.

#### 11062A Kelvin Clip Set

These silver plated Kelvin clips are ideal for constructing your own Kelvin Probe set for 4-wire Ohm measurements. Each set contains 2 clips.





34134A



34135A



34171A



34172A



34397A



34161A



34131A



34330A

34131A  
34134A  
34135A  
34161A  
34171A  
34172A  
34330A  
34397A  
40653B  
E2307A  
E2308A

4

### Low Thermal Cables

These cables are used to minimize error in low voltage measurements. Each kit contains one red and one black cable. Length 1.2 m

- 11053A Low Thermal Lug to Lug Cable
- 11174A Low Thermal Lug to Banana Cable
- 11058A Low Thermal Banana to Banana Cable

### Current Measurement

#### 34134A DC Coupled Current Probe

A clamp on probe for a wide range of applications such as measuring ground currents, powers ripple or current distribution in systems. Output signals: 1 V/A (1 mV/mA) and 10 mV/A. Frequency range: DC to 2 kHz.

#### 34135A DC Coupled Current Probe

A clamp on probe idea for measuring high current electrical systems. Measurement range 1 to 600A (Peak) AC and 1 to 600A DC. Output signal: 1mV/A, Frequency range: DC to 10 KHz.

#### 34330A 30 A Current Shunt

This current shunt can be used to extend the current measurement range. Precision 0.001 Ohm resistor. Output is 1 mV per amp of current passing through the shunt. 15 A continuous; 30A for 15 min continuous.

### Temperature Measurement

#### 40653B Thermistor Surface Assembly

10,000 Ohm thermistor with fast response gives real time measurements. Temperature range: -10° C to 100° C. Accuracy: ±1° C. termination: bare wire.

#### E2307A Type-K Thermocouple Bead Temperature Probe

General-purpose thermocouple temperature probe. Accuracy: -260° C to 110° C, ±2% of reading. Length: 0.9m. Terminated in dual banana plug.

#### E2308A Thermistor Temperature Probe

General purpose temperature probe. 5 KOhm @ 25° C, encapsulated in a stainless steel case. Temperature range: -80° C to 150° C. Accuracy: 0° C to 70° C, ±2%. Time constant: 3 seconds typical.

### Miscellaneous DMM Accessories

#### 34171A DMM Terminal Connector

Provides a convenient and reliable method to connect wires to all five input terminals on the 34401A. Qty 2.

#### 34172A DMM Calibration Short

Provides a convenient and secure method to apply a short to the input connectors of the 34401A for calibration purposes. Qty 2.

#### 34397A 12 Vdc to 115 Vac Inverter

Hit the road and power your instruments from a cigarette lighter with this dc-to-ac inverter. Accepts inputs from 10.5 to 15 V and provides 100 W max. power at 115 Vac.

#### 34161A Accessory Pouch

Cordura pouch fits on top of the 34401A and 34420A voltmeters as well as the 54131/32/81A counter and the 33120A and 33250A function/arb generators.

#### 34131A Basic Instrument Transit Case

Heavy-duty hard-cover carrying case is constructed from rugged A.B.S. and has rubber-grip steel handles and steel latches. The case can be padlocked. For use with 34401A and 34420A voltmeters as well as the 53131/32/81A counter and the 33120A function/arb generator.

34970A

- 3-slot data acquisition and switching mainframe
- 6½-digit (22 bit) internal DMM
- 11 built-in measurement functions

- 8 switch and control plug-in modules
- BenchLink data logger software included



34970A (Front Panel)



34970A (Back Panel)

4

### 34970A Data Acquisition/Switch Unit

The Agilent 34970A is a high performance, low-cost data acquisition and switching mainframe ideal for data logging, data acquisition, and general-purpose switching and control applications. It consists of a half-rack mainframe with an internal 6½-digit (22 bit) digital multimeter. Three module slots are built into the rear of the unit to accept a combination of switch and control modules. Whether you need a few channels of simple data logging or a hundred channels of ATE performance, the 34970A meets your data acquisition needs at a price that meets your budget.

### Measurements You Can Trust

The 34970A incorporates the measurement engine from our best-selling benchtop digital multimeter (DMM). You get the benefit of proven Agilent performance, universal inputs with built-in signal conditioning, and modular flexibility, all in a low-cost, compact data acquisition package. The 34970A features 6½ digits (22 bits) of resolution, 0.004% basic dcV accuracy, and ultra-low reading noise. Combine that with scan rates of up to 250 channels/sec, and you've got the speed and accuracy you need to get the job done.

### Powerful Flexibility

The 34970A's unique design allows per-channel configurability for maximum flexibility and quick, easy setup. The internal autoranging DMM measures 11 different functions directly, eliminating the need for expensive external signal conditioning. Temperature conversion routines are built-in to display raw thermocouple, RTD, or thermistor inputs in degrees C, F, or Kelvin. Use Mx+B scaling to convert linear transducer outputs directly into engineering units. You can even set high/low alarm limits to warn you of out-of-tolerance conditions.

### Custom Configurations That Grow With You

Three module slots and eight switch and control modules allow you to customize the 34970A to meet your unique requirements. Buy only what you need, and add more modules later as your application grows. Measure up to 120 inputs with a single half-rack unit.

### Free BenchLink Software Simplifies Your Data Gathering

If you want PC-based data logging capabilities, but don't want to spend hours programming, BenchLink Data Logger is the answer. Use it to set up your test, acquire and archive measurement data, and perform real-time display and analysis of the incoming measurements.

A familiar spreadsheet environment makes it easy to configure and control your tests. A rich set of colorful graphics provides many options for displaying your data—all with point-and-click ease. Set up multiple graphics using strip charts, histograms, X-Y scatter charts, alarm lights and more. Also use HP BenchLink Data Logger to easily move data to other applications for further analysis, or for inclusion in your presentations and reports.

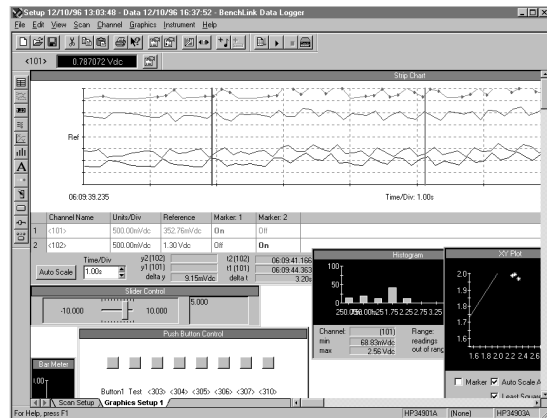
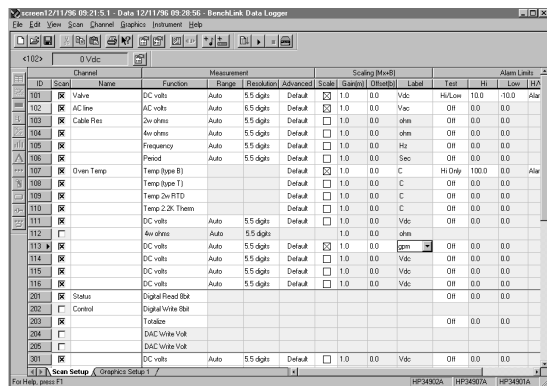

Free BenchLink Data Logger makes PC-based setup and analysis easy.

### Applications

#### Data Logging

Configured with the 34901A 20-channel relay multiplexer, the 34970A becomes a rugged, low-cost data logger that's ideal for quick tests in the lab or in the field. An intuitive front panel with self-guiding menus and a bright, easy-to-read vacuum fluorescent display make standalone set-up fast and easy. All readings are automatically time stamped and stored in a 50,000 reading memory – enough memory to hold a week's worth of data (20 channels scanned every five minutes). The non-volatile memory holds your data even after power is removed, so you can use the 34970A to collect data at a remote location for later uploading to a PC. The system configuration is also held in non-volatile memory, so in the event of a power failure the unit automatically resumes scanning when power is returned. And for PC-based testing, HP BenchLink Data Logger software is included to simplify your test configurations, data analysis and data management.

#### Automated Testing

For automated test and benchtop automation applications, the 34970A's three slots and choice of eight plug-in switch and control modules allow easy customization. The 6½-digit internal DMM brings you the power and performance of a world-class standalone DMM, but in a fraction of the space and at a fraction of the cost. Software drivers that support Agilent VEE and National Instruments LabVIEW are available to make an easy integration of the 34970A into your test system. Standard RS-232 and GPIB interfaces and SCPI programming language make integration even easier. A three-year warranty is also standard, as is our proprietary relay maintenance system which automatically counts and stores every individual switch closure to help you predict relay end-of-life and avoid costly production line downtime.

#### Switching

For test applications that don't require the built-in measurements of the 34970A, the unit can be ordered without the internal DMM. This provides an ultra low-cost solution for routing test signals to and from your device-under-test and assorted instruments, including external DMMs, scopes, counters and power supplies. Plus, you can add the DMM later if your needs change.

### Module Overview

Up to three modules, in any combination, can be inserted into a single mainframe. The 34970A's internal DMM connections are accessible only through the 34901A, 34902A, and 34908A multiplexers. The 34970A accuracy specifications already include the switching offset and reference junction errors shown in the table below; these errors are listed separately for determining system error with external measurement devices.



The **34901A** 20-channel multiplexer is the most versatile module for general-purpose scanning. It combines dense, multi-function switching with 60 channel/second scan rates to address a broad spectrum of data acquisition applications.



The **34902A** 16-channel high-speed multiplexer employs reed relays to achieve scan rates of up to 250 channels-per-second. This module is ideal for high-throughput automated test applications, as well as high-speed data logging and monitoring tasks.



Use the **34903A** 20-channel general-purpose switch module to cycle power to products-under-test, control indicator and status lights, actuate external relays requiring large drive signals, and to build custom switch configurations.



The **34904A** is a two-wire, 4x8 full cross-point matrix that gives you the most flexible connection path between your device-under-test and your test equipment, allowing different instruments to be connected to multiple points on your DUT at the same time.



The **34905A** and **34906A** RF multiplexers offer broadband switching capabilities for high-frequency and pulsed signals to 2 GHz. Use them to route test signals between your device-under-test and your signal generator, oscilloscope, spectrum analyzer, video amplifier, or receiver.



The **34907A** multifunction module allows great flexibility for a variety of sense and control applications. It combines two 8-bit ports of digital input and output, a 100 kHz gated totalizer, and two ±12 V analog outputs—all on a single module.



Use the **34908A** 40-channel single-ended multiplexer for the greatest density in common-low applications, such as battery test, component characterization, and benchtop testing.

### Module Specifications

Module Description	Type	Connects to internal DMM	Speed (ch./sec.)	Maximum Input Voltage, Current, Power	Offset Voltage	Bandwidth	Comments
<b>34901A</b> 20-ch. Multiplexer	2-wire armature (4-wire selectable)	yes	60	300 V 1 A 50 W	< 3 μV	10 MHz	2 current channels (22 ch. total) Built-in cold junction reference
<b>34902A</b> 16-ch. Multiplexer	2-wire reed (4-wire selectable)	yes	250	300 V 50 mA 2 W	< 6 μV	10 MHz	Built-in cold junction reference
<b>34903A</b> 20-ch. Actuator/GP Switch	SPDT / form C	no	120	300 V 1 A 50 W	< 3 μV	10 MHz	—
<b>34904A</b> 4 x 8 Matrix	2-wire armature	no	120	300 V 1 A 50 W	< 3 μV	10 MHz	Full crosspoint
<b>34905A</b> Dual 1: 4 RF Mux, 50 Ω	Common Low (unterminated)	no	60	42 V 0.7 A 20 W	< 6 μV	2 GHz	1 GHz through provided BNC-to-SMB adapter cables
<b>34906A</b> Dual 1: 4 RF Mux, 75 Ω	Common Low (unterminated)	no	60	42 V 0.7 A 20 W	< 6 μV	2 GHz	1 GHz through provided BNC-to-SMB adapter cables
<b>34907A</b> Multifunction Module	Two 8-bit digital I/O ports 26-bit event counter Two analog outputs	no no no	— — —	42 V 400 mA — 42 V — — ± 12 V 10 mA —	— — —	— 100 kHz dc	Open drain Gated; selectable input threshold 16-bit, earth referenced
<b>34908A</b> 40-ch. single-ended Mux	1-wire armature (common low)	yes	60	300 V 1 A 50 W	< 3 μV	10 MHz	No 4-wire measurements

34970A

These are abbreviated specifications. For more detailed information on the 34970A, refer to publication number 5965-5290.

## Accuracy Specifications ± (% of reading + % of range)<sup>1</sup>

Includes measurement error, switching error and transducer conversion error

Function	Range <sup>2</sup>	Frequency, etc.	1 Year 23° C ±5° C
<b>DC Voltage</b>	100.0000 mV		0.0050 + 0.0040
	1.000000 V		0.0040 + 0.0007
	10.00000 V		0.0035 + 0.0005
	100.0000 V		0.0045 + 0.0006
	300.0000 V		0.0045 + 0.0030
<b>True RMS AC Voltage<sup>3</sup></b>	100.0000 mV to 100.0000 V	3 Hz–5 Hz	1.00 + 0.04
		5 Hz–10 Hz	0.35 + 0.04
		10 Hz–20 kHz	0.06 + 0.04
		20 kHz–50 kHz	0.12 + 0.05
		50 kHz–100 kHz	0.60 + 0.08
	100 kHz–300 kHz <sup>4</sup>	4.00 + 0.50	
	300.0000 V	3 Hz–5 Hz	1.00 + 0.08
		5 Hz–10 Hz	0.35 + 0.08
		10 Hz–20 kHz	0.06 + 0.08
		20 kHz–50 kHz	0.12 + 0.12
50 kHz–100 kHz		0.60 + 0.20	
100 kHz–300 kHz <sup>4</sup>	4.00 + 1.25		
<b>Resistance<sup>5</sup></b>	100.0000 Ω 1.000000 kΩ 10.00000 kΩ	1 mA current source	0.010 + 0.004
		1 mA	0.010 + 0.001
		100 μA	0.010 + 0.001
	100.0000 kΩ 1.000000 MΩ 10.00000 MΩ 100.0000 MΩ	10 μA	0.010 + 0.001
		5.0 μA	0.010 + 0.001
		500 nA	0.040 + 0.001
		500 nA    10 MΩ	0.800 + 0.010
<b>Frequency and Period<sup>6</sup></b>	100 mV to 300 V	3 Hz–5 Hz	0.10
		5 Hz–10 Hz	0.05
		10 Hz–40 Hz	0.03
		40 Hz–300 kHz	0.01
			0.01
<b>DC Current (34901A only)</b>	10.00000 mA	<0.1 V burden	0.050 + 0.020
	100.0000 mA	<0.6 V	0.050 + 0.005
	1.000000 A	<2 V	0.100 + 0.010
<b>True RMS AC Current (34901A only)</b>	10.00000 mA and <sup>7</sup> 1.000000 A	3 Hz–5 Hz	1.00 + 0.04
		5 Hz–10 Hz	0.30 + 0.04
		10 Hz–5 kHz	0.10 + 0.04
	100.0000 mA <sup>7</sup>	3 Hz–5 Hz	1.00 + 0.5
		5 Hz–10 Hz	0.30 + 0.5
10 Hz–5 kHz	0.10 + 0.5		

Temperature	Type	Best Range Accuracy <sup>3</sup>	
<b>Thermocouple</b>	B	1100° C to 1820° C	1.2° C
	E	–150° C to 1000° C	1.0° C
	J	–150° C to 1200° C	1.0° C
	K	–100° C to 1200° C	1.0° C
	N	–100° C to 1300° C	1.0° C
	R	300° C to 1760° C	1.2° C
	S	400° C to 1760° C	1.2° C
	T	–100° C to 400° C	1.0° C
<b>RTD</b>	R <sub>0</sub> from 49 Ω to 2.1 kΩ	–200° C to 600° C	0.06° C
<b>Thermistor</b>	2.2 k, 5k and 10k	–80° C to 150° C	0.08° C

## Measurement Characteristics<sup>9</sup>

<b>DC Voltage</b>	
Measurement Method	Continuously integrating multi-slope III A–D Converter
A–D Linearity	0.0002% of reading + 0.0001% of range
Input Resistance	
100 mV, 1 V, 10 V ranges	Selectable 10 MΩ or > 10,000 MΩ
100 V, 300 V ranges	10 MΩ ± 1%
Input Bias Current	< 30 pA at 25° C
Input Protection	300 V all ranges
<b>True RMS AC Voltage</b>	
Measurement Method	AC coupled True RMS—measures the AC component of the input with up to 300 Vdc of bias on any range
Crest Factor	Maximum of 5:1 at full scale
Additional Crest Factor	
Errors (non-sinewave)	Crest Factor 1–2 0.05 % of reading Crest Factor 2–3 0.15 % of reading Crest Factor 3–4 0.30 % of reading Crest Factor 4–5 0.40 % of reading
Input Impedance	1 MΩ ± 2% in parallel with 150 pF
Input Protection	300 Vrms all ranges
<b>Resistance</b>	
Measurement Method	Selectable 4-wire or 2-wire Ohms. Current source referenced to LO input.
Offset Compensation	Selectable on 100 Ω, 1k Ω, 10k Ω ranges
Maximum Lead Resistance	10% of range per lead for 100 Ω and 1 kΩ ranges. 1 kΩ on all other ranges.
Input Protection	300 V on all ranges
<b>Frequency and Period</b>	
Measurement Method	Reciprocal counting technique
Voltage Ranges	Same as AC voltage function
Gate Time	1s, 100 ms, or 10 ms
Measurement Timeout	Selectable 3 Hz, 20 Hz, 200 Hz LF limit
<b>DC Current</b>	
Shunt Resistance	5 Ω for 10 mA, 100 mA; 0.1 Ω for 1 A
Input Protection	1A 250 V fuse on 34901A module
<b>True RMS AC Current</b>	
Measurement Method	Direct coupled to the fuse and shunt. AC coupled True RMS measurement (measures the ac component only).
Shunt Resistance	5 Ω for 10 mA; 0.1 Ω for 100 mA, 1 A
Input Protection	1A 250 V fuse on 34901A module
<b>Thermocouple</b>	
Conversion Conformity	ITS-90 based software routines
Reference Junction Type	Internal, Fixed, or External
Open Thermocouple Check	Selectable per channel. Open >5k Ω.
<b>RTD</b>	Type α = .00385 (DIN) and α = .00392
<b>Thermistor</b>	44004, 44007, 44006 series
<b>Measurement Noise</b>	
<b>Rejection 60 (50) Hz<sup>10</sup></b>	
dc CMRR	140 dB
ac CMRR	70 dB
<b>Integration Time</b>	<b>Normal Mode Rejection<sup>11</sup></b>
200 plc / 3.33s (4s)	110 dB <sup>12</sup>
100 plc / 1.67s (2s)	105 dB <sup>12</sup>
20 plc / 334 ms (400 ms)	100 dB <sup>12</sup>
10 plc / 167 ms (200 ms)	95 dB
2 plc / 33.3 ms (40 ms)	90 dB
1 plc / 16.7 ms (20 ms)	60 dB
< 1 plc	0 dB

<sup>1</sup> Specifications are for 1-hour warm-up and 6½ digits, slow ac filter

<sup>2</sup> 20% over range on all ranges except 300 Vdc and ac ranges and 1 A dc and ac current ranges

<sup>3</sup> For sinewave input > 5% of range. For inputs from 1% to 5% of range and < 50 kHz, add 0.1% of range additional error.

<sup>4</sup> Typically 30% of reading error at 1 MHz, limited to 1 x 108 V Hz

<sup>5</sup> Specifications are for 4-wire ohms function or 2-wire ohms using scaling to remove the offset. Without scaling, add 1 Ω additional error in 2-wire ohms function.

<sup>6</sup> Input > 100 mV. For 10 mV inputs, multiply % of reading error x 10.

<sup>7</sup> Specified only for inputs > 10 mA

<sup>8</sup> 1 year accuracy. For total measurement accuracy, add temperature probe error.

<sup>9</sup> 300 Vdc, ac rms isolation voltage (ch-ch, ch-Earth)

<sup>10</sup> For 1 kΩ unbalance in LO lead

<sup>11</sup> For power line frequency ± 0.1%

<sup>12</sup> For power line frequency ± 1%, use 40 dB or ± 3% use 30 dB



### Operating Characteristics<sup>1</sup>

#### Single Channel Measurement Rates<sup>2</sup>

Function	Resolution	Reading/s
<b>dcV, 2-wire resistance</b>	6% digits (10 plc)	6 (5)
	5% digits (1 plc)	57 (47)
	4% digits (0.02 plc)	600
<b>Thermocouple</b>	0.1° C (1 plc) (0.02 plc)	57 (47) 220
<b>RTD, Thermistor</b>	0.01° C (10 plc)	6 (5)
	0.1° C (1 plc)	57 (47)
	1° C (0.02 plc)	220
<b>acV</b>	6% Slow (3 Hz)	0.14
	6% Med (20 Hz)	1
	6% Fast (200 Hz)	8
	6% <sup>3</sup>	100
<b>Frequency, Period</b>	6% digits (1s gate)	1
	5% digits (100 ms)	9
	4% digits (10 ms)	70

System Speeds <sup>4</sup>	Channel/s
<b>INTO Memory</b>	
Single channel dcV	600
34902A scanning dcV	250
34907A scanning digital in	250
34902A scanning dcV with scaling and 1 alarm fail	220
34907A scanning totalize	170
34902A scanning temperature 160	
34902A scanning acV <sup>5</sup>	100
34902A scanning dcV/Ohms on alternate channels	90
34901A/34908A scanning dcV	60
<b>INTO and OUT of memory to GPIB or RS-232 (init/fetch)</b>	
34902A scanning dcV	180
34902A scanning dcV with timestamp	150
<b>OUT of memory to GPIB</b>	
Readings	800
Readings with timestamp	450
Readings with all format options ON	310
<b>OUT of memory to RS-232</b>	
Readings	600
Readings with timestamp	320
Readings with all format options ON	230
<b>DIRECT to GPIB or RS-232</b>	
Single channel dcV	440
34902A scanning dcV	200
Single channel MEAS DCV10/MEAS DCV 1	25
Single channel MEAS DCV/ MEAS OHMS	12
<b>HP BenchLink Performance</b>	
Scan and save to disk with 2 strip-charts displayed	100

### System Characteristics

<b>Scanning Inputs</b>	
Analog	34901A, 34902A, and 34908A multiplexer channels
Digital	34907A digital in and totalize
Scan list	Scans channels in ascending order
<b>Triggering</b>	
Source	Interval, external, button press, software, or on monitor channel alarm
Scan count	1 to 50,000 or continuous
Scan interval	0 to 99 hours; 1 ms step size
Channel delay	0 to 60 seconds per channel; 1 ms step size
External trig delay	< 2 ms. With monitor on < 200 ms.
External trig jitter	< 2 ms
<b>Alarms</b>	
Analog inputs	Hi, Lo, or Hi + Lo evaluated each scan
Digital inputs	34907A digital in: maskable pattern match or state change 34907A totalize: Hi limit only
Monitor channel	Alarm evaluated each reading
Alarm outputs	4 TTL compatible; selectable TTL logic Hi or Lo on fail
Latency	5 ms (typical)

<b>Memory</b> (Battery backed, 4 year typical life <sup>5</sup> )	
Readings	50,000 with timestamp Readable during scan
States	5 instrument states with user label
Alarm queue	Up to 20 events with channel number, reading, and timestamp
<b>System Features</b>	
Per-channel math	Individual Mx + B scaling and Min/Max/Average calculated real time
Power fail recovery	Resumes scanning automatically
Relay maintenance	Counts each relay closure and stores on module. User resettable.
Real time clock	Battery-backed, 4 year typical life <sup>5</sup>

#### BenchLink Data Logger software (not included with Option 001)

<b>System Requirements<sup>6</sup></b>	
PC Hardware	486, 66 MHz, 16 MB RAM, 12 MB disk space
Operating Systems	Windows 3.1/95/98, Windows NT 4.0
<b>Computer Interfaces<sup>7</sup></b>	
GPIB	82335B, 82340A/B/C, 82341A/B/C/D National Instruments AT-GPIB/TNT, PCI-GPIB E2050A (Windows 95 and NT only)
LAN -to- GPIB	PC COM 1-4
RS-232 (Serial Port)	

<sup>1</sup> Reading speeds for 60 Hz and (50 Hz) operation

<sup>2</sup> For fixed range and function, readings to memory, scaling and alarms off, autozero off

<sup>3</sup> Maximum limit with default settling delays defeated

<sup>4</sup> Speeds are for 4 1/2 digits, delay 0, display off, autozero off. Using 115 kB RS-232 setting.

<sup>5</sup> Storage at temperatures above 40° C will decrease battery life

<sup>6</sup> Software provided on CD-ROM and includes utility to create floppy disks for installation

<sup>7</sup> Interface and driver must be purchased separately

### General

**Power Supply:** 100 V/120 V/220 V/240 V ±10%  
**Power Line Frequency:** 45 Hz to 66 Hz automatically sensed  
**Power Consumption:** 12 W (25 VA peak)  
**Operating Environment:**  
 Full accuracy for 0° C to 55° C  
 Full accuracy to 80% R.H. at 40° C  
**Storage Environment:** -40° C to 70° C  
**Weight:** Net: 3.6 kg (8.0 lbs)  
**Safety:** Conforms to CSA, UL-1244, IEC 1010 Cat I  
**RFI and ESD:** CISPR 11, IEC 801/2/3/4  
**Warranty:** 3 years

### Ordering Information

**34970A** Data Acquisition/Switch Unit  
 Includes internal 6 1/2 digit DMM, operating and service manuals, test report, power cord, and Quick Start package (includes HP Benchlink Data Logger software, RS-232 cable, thermocouple, and screwdriver). Modules are purchased separately and are required to operate.

**Opt 001** Delete Internal DMM

Same as above but deletes DMM and quick start package.

Order 34970-80010 to retrofit DMM at a later time.

**Opt 1CM** Rackmount Kit

**Opt 0B0** Delete Manual Set

**34901A** 20-Channel Armature Multiplexer

**34902A** 16-Channel Reed Multiplexer

**34903A** 20-Channel Actuator/General Purpose Switch

**34904A** 4 x 8 Two-Wire Matrix Switch

**34905A** Dual 4-Channel RF Multiplexer, 50 Ohms

Includes (10) SMB-to-BNC(f) 50 Ω adapter cables

**34906A** Dual 4-Channel RF Multiplexer, 75 Ohms

Includes (10) SMB-to-BNC(f) 75 Ω adapter cables

**34907A** Multifunction Module

**34908A** 40-Channel Single-Ended Multiplexer

#### Accessories

**34161A** Accessory Pouch

**34131A** Hard Carrying Case

**34397A** dc-to-ac Inverter

**E2050A** LAN/GPIB Gateway

**34970-80010** DMM Field Installation Kit

Fully calibrated with Test Report and Quick Start Kit

For more information on high-performance data acquisition products from Agilent Technologies, refer to the Data Acquisition Systems section of this catalog starting on page 530.



The 33120A's and 33250A's functions and arbitrary waveforms are accurate and convenient to set up. Also, available software makes it easy to download modeled or captured waveforms.

## Find Your Fit in the Agilent Technologies Family

Besides producing sine waves accurate in frequency and amplitude, function generators and waveform synthesizers are versatile signal sources that can produce some or all of the following waveforms: square, triangle, ramp and pulse. Tuning is continuous over wide bands, and many models can modulate these waveforms and sweep them across a range of frequencies. Some function generators and all waveform synthesizers use frequency synthesis techniques to generate their outputs. Applications for these general purpose signal sources are diverse. Examples include speed sensor characterization, communications receiver design and test, and earthquake testing.

Some waveform synthesizers can also produce arbitrary waveforms, programmable at the front panel or on a PC and downloaded. This capability allows creating signals that mimic noise, vibration, control pulses, whatever signal is needed for realistic tests. A typical use for arbitrary waveforms is to simulate specific ECG waveforms to verify that an electronic hospital patient monitor responds in the proper manner.

From complex signals to simple waveforms, there is an Agilent generator that is right for the job. See the table and the individual product pages for more detail.

### 33120A

The 33120A uses the latest direct digital synthesis techniques to bring you a full-featured 15 MHz function generator that also has arbitrary waveform capability built in. The 33120A offers both linear and log sweep, internal AM, FM, FSK, and burst modulation, and a 12-bit, 40 MSa/s, 16,000 point deep arb generator. Option 001 phase lock/timebase increases the 33120A frequency stability and allows multiple 33120A's to produce precise phase-offset signals. Fully programmable, the 33120A includes both GPIB and RS-232 interfaces standard. An optional software package, the 34811A BenchLink/Arb, facilitates creating, modifying, and downloading arbitrary waveform to the 33120A.

### 33250A

For a higher-performance solution, the 33250A provides a full-featured 80 MHz Function/Arbitrary waveform generator with 50 MHz pulse capabilities. It not only provides a wide variety of standard waveforms, but also arbitrary waveforms with 12-bit resolution, 64K-point deep memory, and a sample rate of 200 MSa/s. In addition, it has both linear and logarithmic sweep, burst, as well as internal and external AM, FM, and FSK modulation capabilities all in a half-width package. External clock reference allows multiple 33250A's to be used with precise phase-offset signals, or with an external 10 MHz system clock. With GPIB and RS-232 provided standard, the 33250A is fully programmable, and perfectly suited for stand-alone bench and system applications.

### 8904A

The 8904A creates complex signals from six simple waveforms. The instrument offers standard functions, dc, and noise. Option 001 adds three more internal sources (total of four) which can be digitally summed together. Option 001 also adds AM, FM, PM, DSBSC, and pulse modulation using these three internal sources. In addition, Option 001 adds sequencing capabilities. These features address VOR, FM Stereo, and communications signaling applications. Option 002 adds a second independent synthesizer output. Option 005 allows multiple units to be phase synchronized to create complex waveforms with high timing accuracy.

## Function and Arbitrary Waveform Generator Specifications

	33120A	33250B	8904A
<b>Waveforms</b>			
Sine	100 $\mu$ Hz to 15 MHz	1 $\mu$ Hz to 80 MHz	DC to 600 KHz
Square	100 $\mu$ Hz to 15 MHz	1 $\mu$ Hz to 80 MHz	.1 Hz to to 50 KHz
Triangle/Ramp	100 $\mu$ Hz to 100 kHz	1 $\mu$ Hz to 1 MHz	.1 Hz to to 50 KHz
Pulse		500 $\mu$ Hz to 50 MHz	.1 Hz to to 50 KHz
Arbitrary			
Length	8 to 16,000 points	1 to 64K points	–
Vertical resolution	12 bits (including sign)	12 bits (including sign)	–
Sample rate	40 MSa/s	200 MSa/s	–
DC	$\pm 5$ Vpk into 50 $\Omega$	$\pm 5$ Vpk into 50 $\Omega$	$\pm 5$ Vpk into 50 $\Omega$
<b>Output (into 50 <math>\Omega</math>)</b>			
Amplitude (p-p)	50 mVpp to 10 Vpp	10 mVpp to 10 Vpp	10 Vpp
DC Offset	$\pm 5$ Vpk ac + dc	$\pm 5$ Vpk ac + dc	5 Vpp
Impedance	50 $\Omega$	50 $\Omega$	50 $\Omega$
<b>Modes</b>			
Trigger	int/ext	int/ext	Creates signals from six basic waveforms
Gate	ext	ext	
Counted Burst (cycles)	1 to 50,000 or infinite	1 to 1,000,000 or infinite	
<b>Modulation</b>			
AM	int/ext, including arbitrary	int/ext, including arbitrary	internal
FM	int, including arbitrary	int/ext, including arbitrary	internal
FSK	int/ext, including arbitrary	int/ext, including arbitrary	internal
PM	–	–	internal
<b>Sweep</b>			
Linear	int/ext trigger	int/ext trigger w/ marker	internal
Logarithmic	int/ext trigger	int/ext trigger w/ marker	none
<b>Interface</b>	GPIB and RS-232	GPIB and RS-232	GPIB
<b>Catalog Page</b>	161	163	159

- Sine to 600 kHz, square, ramp, triangle to 50 kHz
- 12-bit direct digital synthesis
- Tone, DTMF, digital, Hop Ram sequence modes
- One or two outputs
- One to four internal channels
- AM, FM,  $\emptyset$ M, DSBSC, and pulse modulation
- Unit-to-unit phase synchronization
- Optional 600  $\Omega$  high power, balanced output



8904A

## 8904A Function Synthesizer



The standard 8904A multi-function synthesizer generates accurate sine waves from 0 Hz to 600 kHz with 0.1 Hz resolution. The 8904A also has five other standard functions: square, triangle, ramp, from 0 Hz to 50 kHz plus dc, and Gaussian white noise. All waveform values in the 8904A are digitally calculated in real time by Agilent's Digital Waveform Synthesis IC yielding 12-bit digital accuracy. Full GPIB programmability is also included standard on the 8904A.

### Two Outputs

Option 002 adds a second, identical synthesizer and floating 50  $\Omega$  output section to the 8904A. Frequency, amplitude, waveform, and phase can be independently set for the two sources. Either synthesizer can be precisely varied in phase relative to each other from 0 degrees to 359.9 degrees with a resolution of 0.1 degree.

### Complex Signal Generation

Option 001 adds internal synthesizers (for a total of four) which can modulate channel A or be summed to give complex waveform generating capabilities to the 8904A. All four synthesizers are independent with precise phase offset capabilities. These synthesizers can be digitally summed before being output. In addition to summing, Option 001 allows channels B, C, and D to modulate channel A with AM, FM,  $\emptyset$ M, DSBSC, or pulse modulation.

### FM Stereo Composite Mode

Option 001 also includes a mode for generating FM stereo composite signals. Test signals in this mode include Left = Right, Left = - Right, Left Only, and Right Only. Single keystrokes select test-tone frequency, composite level, test signal mode, and pilot tone level. Stereo separation is typically greater than 65 dB.

### Communication Signaling

Option 001 also adds four sequence modes to the 8904A: tone, DTMF, digital, and Hop Ram sequence modes. These modes make the 8904A a powerful tool for use in communications signaling. Tone and DTMF modes allow creation of single or dual tone sequences up to 750 states in length. Digital sequence mode can generate bit streams up to 3000 bits in length with 100  $\mu$ s resolution. Hop Ram sequence mode allows sequencing of 16 tones, each with an associated amplitude, frequency, and phase value.

### Fast Hop

Option 003 adds the ability to externally hop channel A in frequency, phase, or amplitude. Up to 16 frequency/phase/amplitude states can be entered into the Hop Ram memory. To hop, an external device must address the four-bit wide, TTL-level address bus provided on the rear panel. Phase continuous switching can be done in as little as 20  $\mu$ s.

### Unit-to-Unit Phase Synchronization

With Option 005, multiple 8904As can be phase synchronized to provide more than two phase-related outputs. In the synchronous mode, one unit is specified to be the master clock unit and all others are designated slaves. Two signals are then routed from the clock master unit to all slave units through external low-loss power splitters. To synchronize the units, a phase reset command is given to the master 8904A via GPIB or from the front panel. The total phase error between units will be the larger of  $\pm 0.1$  degree or 60 ns for frequencies from 0.1 Hz to 100 kHz. Up to eight 8904As may be synchronized.

### 600 $\Omega$ Balanced Output

Option 006 changes output 1 from a 50  $\Omega$  electronically-floating output to a transformer-coupled, 600  $\Omega$  -balanced output. Option 006 provides high power, balanced signals into 600  $\Omega$  loads. Maximum output is 10 volts rms into 600  $\Omega$ . The Option 006 output restricts the frequency range of output 1 to 30 Hz to 100 kHz. In addition, complex wave forms such as square, ramp, and triangle waveforms are degraded and dc cannot be passed through the Option 006 output. In many applications, however, the 8904A Option 006 is a direct replacement for the 200CD wide range oscillator.

### 8904A Specifications (for 50 $\Omega$ output only)

#### Frequency

**Range:** Sine wave: 0 Hz to 600 kHz  
Square, triangle, ramp: 0 Hz to 50 kHz  
**Resolution:** 0.1 Hz  
**Accuracy** (internal 10 MHz timebase): 50 ppm

#### AC Amplitude (sine wave only)

**Range:** 0 to 10 V p-p into a 50  $\Omega$  load  
**Accuracy** (> 40 mV p-p into open circuit):  
1%, 0.1 Hz to 100 kHz; 3%, 100 kHz to 600 kHz  
**Flatness** (> 630 mV p-p into 50  $\Omega$ ):  
 $\pm 0.1\%$  ( $\pm 0.009$  dB), 0.1 Hz to 100 kHz

#### DC Amplitude

**Range:** 0 to  $\pm 10$  V p-p open circuit  
**Accuracy:** Larger of  $\pm 20$  mV or  $\pm 2.1\%$

#### Spectral Purity (sine wave only)

**THD + N** (including spurs, amplitude > 50 mV rms into 50  $\Omega$ ):  
-63 dBc rms (0.07%), 20 Hz to 7.5 kHz, 30 kHz BW  
-63 dBc rms (0.07%), 7.5 kHz to 20 kHz, 80 kHz BW

#### Gaussian Noise

**Spectral Characteristic:** Equal energy per unit bandwidth ("white")  
**Time-Domain Characteristic:** Gaussian distribution  
**Flatness** (>100 mV p-p): Typically  $\pm 0.5$  dB, 0.1 Hz to 100 kHz

### Option 001 Specifications

Modulation is for channel A only, and specified for sine-wave carrier and modulation. External modulation is NOT possible.

#### Modulation

##### Amplitude

**Rate:** 0 to 600 kHz  
**Depth Range:** 0% to 100 % of carrier amplitude

##### Frequency

**Rate:** 0 to 600 kHz  
**Deviation Range:** 0 to 600 kHz

##### Phase

**Rate:** 0 to 600 kHz  
**Deviation Range:** 0° to 179.9°/channel

##### Pulse or DSBSC

**Rate:** 0 Hz to 50 kHz (up to 600 kHz for DSBSC)

#### Summation

Two, three, or four channels may be summed.

**Channel to Channel Phase Accuracy** (equal amplitude sine waves): Larger of  $\pm 0.1^\circ$  or 30 ns, 0.1 Hz to 100 kHz

#### Modes

##### FM Stereo Composite

**Test Modes:** Left = Right, Left = -Right, Left Only, Right Only  
**Composite Signal Level:** Up to 10 V<sub>rms</sub> into 50  $\Omega$   
**Pre-Emphasis Modes:** Off, 25  $\mu$ s, 50  $\mu$ s, and 75  $\mu$ s  
**Channel Separation:** Typically > 65 dB, 20 Hz to 15 kHz rates

##### Tone Sequence

**Number of Frequencies:** 16 tones each with user-definable frequency, on-time and off-time  
**On/Off Time Duration Range:** 0 ms, 0.80 ms to 655.35 ms  
**Timing Accuracy:**  $\pm 0.02$  ms ( $\pm 20$   $\mu$ s)  
**Sequence Length:** 750 steps, user-definable

##### DTMF Sequence

**Number of Tone Pairs:** 16 standard DTMF tone pairs (0-9, A-D, #, \*) with user-definable on-time and off-time  
**On/Off Time Duration Range:** 0 ms, 1.00 ms to 655.35 ms  
**Timing Accuracy:**  $\pm 0.02$  ms ( $\pm 20$   $\mu$ s)  
**Sequence Length:** 750 steps, user-definable

##### Digital Sequence

**User Definable:** On level, off level, and bit period  
**Bit Period Duration Range:** 0.10 ms to 655.35 ms  
**Timing Accuracy:**  $\pm 0.02$  ms ( $\pm 20$   $\mu$ s)  
**Sequence Length:** Up to 3000 bits, user-definable

##### Hop Ram Sequence

**Number of Frequencies:** 16 tones each with user-definable frequency, phase, and amplitude  
**Sequence Clock Frequency Range:** 0.1 Hz to 10 kHz  
**Sequence Length:** 750 steps (all 16 tones used) or 3000 steps (tones 0 and 1 used), user-definable

### Option 002 Specifications (50 $\Omega$ outputs)

**Output 1 to Output 2 Phase Accuracy** (sine waves at the same frequency):  $\pm 0.1^\circ$  or 30 ns, 0.1 Hz to 100 kHz, whichever is greater

### Option 003 Specifications (Fast Hop)

**Direct Hopping of Channel A:** 16 phase-frequency-amplitude states may be addressed with four TTL-compatible inputs  
**Switching Speed** (via digital port): Typically < 20  $\mu$ s

### Option 005 Specifications (50 $\Omega$ outputs)

**Unit-to-Unit Phase Accuracy** (sine waves only): Larger of  $\pm 0.1^\circ$  or 60 ns, 0.1 Hz to 100 kHz  
**Maximum Number of Synchronized Units:** 8 units

### Option 006 Specifications (sine wave)

All specifications for the standard 50  $\Omega$  output 8904A are degraded by the accuracy, flatness, and distortion specifications of the Option 006, 600  $\Omega$  transformer coupled output.

**Output Type:** Fully floating/balanced transformer-coupled output

**Usable Frequency Range:** Typically 30 Hz to 200 kHz

**AC Amplitude Range:** 0 to 10 V<sub>rms</sub> into 600  $\Omega$

**AC Amplitude Accuracy** (> 40 mV<sub>rms</sub> into a balanced 600  $\Omega$  load):

6% (0.5 dB), 30 Hz to 20 kHz; 12% (1.0 dB), 30 Hz to 100 kHz

**Flatness** (> 40 mV<sub>rms</sub> into a balanced 600  $\Omega$  load):

+ 0.15 dB, - 0.75 dB, 30 Hz to 100 kHz

**THD + Noise** (including spurs, > 140 mV<sub>rms</sub> into a balanced 600  $\Omega$  load):

- 63 dB (0.07%), 7.5 kHz to 20 kHz, 80 kHz BW

#### General

**Store Recall:** 35 non-volatile registers

**Output Type** (standard unit): 50  $\Omega$  electronic floating or grounded output, GPIB programmable

**Maximum Float Voltage** (50  $\Omega$  output, signal + float): 10 V peak maximum from high or low output to chassis ground

**External Timebase Input:** 10 MHz accepted at a nominal level of 0.1 to 5 V peak, automatic switching

**Operating Temperature Range:** 0° to 50° C

**Storage Temperature Range:** -20° to 70° C

**Remote Operation:** GPIB

**Size:** 133 mm H x 213 mm W x 513 mm D (5.25 in x 8.36 in x 20.2 in)

**Weight:** Net, 5.9 kg (12.8 lb); shipping, 13 kg (28.6 lb)

#### Key Literature

8904A Technical Specifications, p/n 5965-9456E

8904A Brochure, p/n 5965-9457E

#### Ordering Information

**8904A** Multifunction Synthesizer<sup>1</sup>

**Opt 001** Adds three (two when ordered with Option 002) internal channels, Channel A modulation, summation, FM stereo mode, and sequence capability

**Opt 002** Adds second internal synthesizer and output

**Opt 003** Adds fast hop and digital modulation

**Opt 004** Connectors on rear panel only

(not available with Option 005 or 006)

**Opt 005** Adds unit-to-unit phase synchronization

**Opt 006** Changes output 1 from a 50  $\Omega$  output to

a transformer-coupled, 600  $\Omega$  balanced output

**Opt 910** Provides an additional operation and

calibration manual (08904-90007) and two

service manuals (08904-90008)

**Opt 915** Adds Service Manual (08904-90008)

**Opt W30** Extended Repair Service

**Opt W32** Calibration Service

**08904-61024** Rackmount Kit for a single 8904A

**08904-61025** Rackmount Kit for mounting two

8904A's side by side

**8904A** Retrofit Kits (customer retrofittable)

**11816A** Retrofit Kit for Option 001

**11817A** Retrofit Kit for Option 002

**11818A** Retrofit Kit for Option 003

<sup>1</sup> GPIB cables not included.

<sup>2</sup> Not available for units with serial prefix less than 2948A.

 Indicates QuickShip availability.





- 15 MHz sine- and square-wave outputs
- Sine, triangle, square, ramp, noise, and more
- 12-bit, 40 MSa/s, 16,000 point deep arbitrary waveforms
- Direct digital synthesis for excellent stability
- Linear and log sweeps built-in
- AM, FM, FSK, and burst modulation built-in
- GPIB and RS-232 interfaces both standard
- Optional BenchLink Arb software



33120A

33120A

### 33120A Function/Arbitrary Waveform Generator



The Agilent 33120A is a high-performance, full-function 15 MHz synthesized function generator. It features sine, triangle, square, ramp, and noise waveforms, a 12-bit, 40 MSa/s, 16,000 point deep arbitrary waveform generator, and both internal sweep and modulation capabilities. The 33120A is ideal for both bench and system applications. Both GPIB and RS-232 interfaces are standard, as is a full three-year warranty. All this is available for a surprisingly affordable price.

#### Unprecedented Functionality

The 33120A will fill all your basic signal source needs by giving you a full complement of standard functions. But this source goes beyond the basics. You get both linear and log sweeps to 15 MHz, plus full-modulation capabilities. AM, FM, FSK, and burst modulation are just a button push away. You can internally modulate with any of the standard waveforms as well as Arb. You can even use an external source for AM, FSK, and burst modulation, if desired. Finally, you get near-infinite custom waveform capability with the inclusion of a 12-bit, 40 MSa/s, 16,000 point deep arbitrary waveform generator.

#### Superb Performance

The performance of the 33120A was designed in, not left out. This means that you get clean, low-distortion sine waves, fast rise- and fall-time squarewaves, and linear triangle and ramp waveforms. Further, due to the latest direct digital synthesis techniques utilized in the 33120A, you can get down to 10  $\mu$ Hz frequency resolution.

#### Built-In Versatility

You will find that the 33120A will fit equally well into your bench or your system applications. Designed with the bench user in mind, operation of the 33120A from the front panel is straightforward and intuitive. The inclusion of a knob makes adjusting frequency, amplitude, and offset extremely convenient. Or enter these values directly. You can even enter amplitude values directly in V peak-to-peak, V rms, or dBm. For system applications, the 33120A includes both GPIB and RS-232 interfaces standard, and uses commands that are in total compliance with the Standard Commands for Programmable Instrumentation (SCPI).

#### Quality and Reliability

Not only does the 33120A offer you performance and features unheard of at this price, you also get the advantages of owning Agilent Technologies. A full three-year warranty is standard with the 33120A. The rugged construction and conservative design of the 33120A ensures many years of trouble-free operation. Just as price was designed out of the 33120A, quality and reliability were designed in.

#### Option 001 External Clock Reference

Option 001 adds a high-stability timebase, the ability to lock to an external timebase, and the ability to phase lock two or more 33120As together. This option is especially useful if your application requires higher-frequency stability and accuracy, if you need to lock to an external-frequency standard, or if you need two or more phase-locked outputs.

4

#### BenchLink Arb Software Helps the 33120A Work for You

BenchLink Arb lets you use your Windows-based PC (95, 98, NT 4.0) to easily create and edit arbitrary waveforms for output on the 33120A.

BenchLink Arb software application lets you create waveforms in a variety of ways:

- Select and edit a standard waveform from the BenchLink Arb library, and change its amplitude and frequency characteristics as desired.
- Use BenchLink Arb's drawing tools to draw and edit your own custom waveform.
- Bring in and edit a waveform captured or created elsewhere.

BenchLink Arb accepts time/voltage pairs in ASCII format, or you can use waveforms captured with BenchLink Scope and an oscilloscope. Once your waveform is ready, downloading to the 33120A generator is simple. Make your arbitrary waveforms quickly and easily with BenchLink Arb.

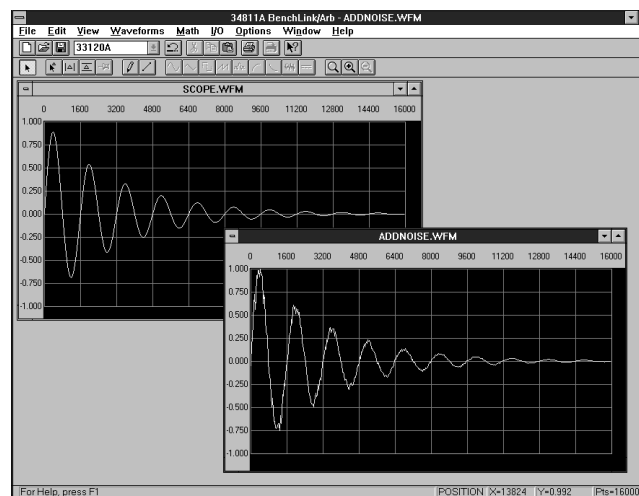

34811A BenchLink Arb lets you take control of arbitrary waveforms on the 33120A function/arbitrary waveform generator.

33120A

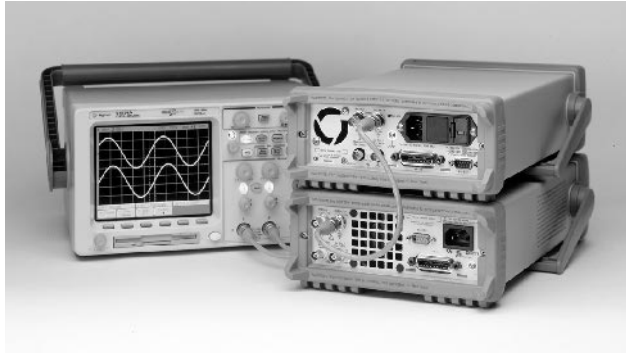

33120A Option 001

## Abbreviated Technical Specifications

### Waveforms

**Standard:** Sine, square, triangle, ramp, noise, sin(x)/x, exponential rise, exponential fall, heartbeat, dc volts

### Arbitrary

- Waveform Length:** 8 to 16,000 points
- Amplitude Resolution:** 12 bits (including sign)
- Sample Rate:** 40 MSa/s
- Non-Volatile Memory:** Four (4) 16,000 point waveforms

### Frequency Characteristics

- Sine:** 100  $\mu$ Hz to 15 MHz
- Square:** 100  $\mu$ Hz to 15 MHz
- Triangle:** 100  $\mu$ Hz to 100 kHz
- Ramp:** 100  $\mu$ Hz to 100 kHz
- Noise (Gaussian):** 10 MHz bandwidth
- Resolution:** 10  $\mu$ Hz or 10 digits
- Accuracy:** 10 ppm in 90 days, 20 ppm in 1 year, 18° C to 28° C
- Temp. Co-eff.:** <2 ppm/° C
- Aging:** <10 ppm/yr.

### Sine-wave Spectral Purity

#### Harmonic Distortion:

- DC to 20 kHz: -70 dBc
- 20 kHz to 100 kHz: -60 dBc
- 100 kHz to 1 MHz: -45 dBc
- 1 MHz to 15 MHz: -35 dBc

#### Spurious (non-harmonic):

- DC to 1 MHz: <-65 dBc
- 1 MHz to 15 MHz: <-65 dBc + 6 dB/octave

**Total Harmonic Distortion:** <0.04% (dc to 20 kHz)

**Phase Noise:** <-55 dBc in a 30 kHz band

### Signal Characteristics

#### Squarewave

- Rise/Fall Time:** < 20 ns
- Overshoot:** < 4%
- Asymmetry:** <1% + 5 ns
- Duty Cycle:**
  - 20% to 80% (to 5 MHz)
  - 40% to 60% (to 15 MHz)

#### Triangle, Ramp, Arb

- Rise/Fall Time:** 40 ns (typical)
- Linearity:** <0.1% of peak output
- Settling Time:** < 250 ns to 0.5% of final value
- Jitter:** < 25 ns

### Output Characteristics

- Amplitude** (into 50  $\Omega$ ): 50 mV p-p to 10 V p-p
- Accuracy** (at 1 kHz): 1% of specified output
- Flatness** (sine wave relative to 1 kHz)
  - <100 kHz  $\pm$ 1% (0.1 dB)
  - 100 kHz to 1 MHz  $\pm$ 1.5% (0.15 dB)
  - 1 MHz to 15 MHz  $\pm$ 2% (0.2 dB) Ampl  $\geq$ 3 Vrms
  - $\pm$ 3.5% (0.3 dB) Ampl <3 Vrms

- Output Impedance:** 50  $\Omega$  (fixed)
- Offset** (into 50  $\Omega$ ):  $\pm$  5 Vpk ac + dc
- Accuracy:**  $\pm$  2% of setting + 2 mV
- Resolution:** 3 digits, amplitude and offset
- Units:** V p-p, V rms, dBm
- Isolation:** 42 Vpk maximum to earth
- Protection:** Short circuit protected,  $\pm$ 15 Vpk overdrive <1 minute

### Modulation

#### AM

- Carrier 3dB Freq.:** 10 MHz (typical)
- Modulation:** Any internal waveform including Arb
- Frequency:** 10 mHz to 20 kHz
- Depth:** 0% to 120%
- Source:** Internal/external

#### FM

- Modulation:** Any internal waveform including Arb
- Frequency:** 10 mHz to 10 kHz
- Peak Deviation:** 10 mHz to 15 MHz
- Source:** Internal only

#### FSK

- Internal Rate:** 10 mHz to 50 kHz
- Frequency Range:** 10 mHz to 15 MHz
- Source:** Internal or external (1 MHz max)

#### Burst

- Carrier Freq.:** 5 MHz max.
- Count:** 1 to 50,000 cycles or infinite
- Start Phase:** -360° to +360°
- Internal Rate:** 10 mHz to 50 kHz  $\pm$ 1%
- Gate Source:** Internal or external gate
- Trigger Source:** Single, external, or internal rate

### Sweep

- Type:** Linear or logarithmic
- Direction:** Up or down
- Start F/Stop F:** 10 mHz to 15 MHz
- Speed:** 1 ms to 500 s  $\pm$  0.1%
- Trigger:** Internal, external, single

### Rear Panel Inputs

- Ext. AM Modulation:**  $\pm$  5 Vpk =100% modulation, 5 k $\Omega$  input resistance
- External Trigger/FSK/Burst Gate:** TTL low true

## General Specifications

- State Storage Memory:** Power off state automatically saved. 3 user-configurable stored states.
- Interface:** IEEE-488 and RS-232 standard
- Language:** SCPI-1991
- Warranty:** 3 years standard

## Option 001 External Clock Reference/TCXO Timebase

- Stability:**  $\pm$ 1 ppm, 0° to 50° C
- Aging:** < 2 ppm in first 30 days (continuous operation); 0.1 ppm/month (after first 30 days)
- Ext. Reference Input Lock Range:** 10 MHz  $\pm$  50 Hz
- Int. Reference Output Frequency:** 10 MHz
- Phase Offset:** -360° to +360°, 0.001° resolution

For more information, visit our web site: [www.agilent.com/find/gp](http://www.agilent.com/find/gp)

## Ordering Information

- 33120A Function Generator
- Opt 001 External Clock Reference
- Opt 106 HP BenchLink/Arb Software
- Opt 1CM Rackmount Kit
- 34811A HP BenchLink/Arb Software
- 34161A Accessory Pouch

 Indicates QuickShip availability.



- 80 MHz sine and square waveforms
- Sine, square, triangle/ramp, pulse, noise, and more
- 50 MHz pulse with variable edge times
- 200 MSa/s, 12-bit, 64K-point deep arbitrary waveforms
- Sweep (lin/log), burst (gated/counted/triggered) and modulation (AM/FM/FSK)
- GPIB and RS-232 interfaces standard



33250A

### 33250A Function/Arbitrary Waveform Generator



The Agilent Technologies 33250A uses direct digital-synthesis (DDS) techniques to create a stable, accurate output on all waveforms, down to 1  $\mu$ Hz frequency resolution. The benefits are apparent in every signal you produce, from the sine wave frequency accuracy to the fast rise/fall times of square waves to the ramp linearity.

Front-panel operation of the 33250A is straightforward and user friendly. The knob or numeric keypad can be used to adjust frequency, amplitude and offset. You can even enter voltage values directly in Vpp, Vrms, dBm, or high/low levels. Timing parameters can be entered in Hertz (Hz) or seconds.

#### Custom Waveform Generation

Why settle for a basic function generator when you can get arbitrary waveforms at no extra cost? With the 33250A, you can generate arbitrary waveforms with 12-bit vertical resolution, 64K point memory depth, and a sample rate of 200 MSa/s. You can also store up to four 64K-deep arbitrary waveforms in non-volatile memory with user-defined names to help you find the right waveform when you need it most. Optional BenchLink Arb software lets you use your Windows-based PC (95, 98, NT 4.0) to easily create and edit arbitrary waveforms.

#### Pulse Generation

The 33250A can generate simple pulses up to 50 MHz. Edge times can be set as low as 5 ns. Voltage levels can be set as amplitude and offset, or as high and low levels. With period and pulse width parameters, the 33250A is ideally suited to a wide variety of pulse applications.

#### Built-In Versatility

AM, FM, and FSK capabilities make it easy to modulate waveforms with or without a separate source. You can internally modulate with any of the standard waveforms as well as Arb or use an external source. Linear or logarithmic sweeps can be performed with an adjustable frequency marker signal. Programmable burst count (from 1 to 1,000,000 or infinite cycles) and gating allow you to further customize your signal.

For system applications, both GPIB and RS-232 interfaces are standard, and support full programmability using SCPI commands.

#### Color Graphical Display

The unique design of the 33250A combines a low-profile instrument with the benefits of a color graphical display. Now you can display an image of the output waveform with multiple parameters at the same time. The graphical interface also allows quick and easy modifications to arbitrary waveforms.

#### Quality and Reliability

The 33250A's TCXO timebase gives you frequency accuracy of 1 ppm for your most demanding applications. The external clock reference input/output lets you synchronize to an external 10 MHz clock.

A full three-year warranty is standard with the Agilent 33250A.

33250A

### Abbreviated Technical Specifications

#### Waveforms

**Standard:** Sine, square, ramp/triangle, noise, sin(x)/x, exponential rise, exponential fall, cardiac, DC volts

#### Arbitrary

- Waveform Length:** 1 to 64K points
- Amplitude Resolution:** 12 bits (including sign)
- Sample Rate:** 200 MSa/s
- Non-Volatile Memory:** Four (4) 64K waveforms

#### Frequency Characteristics

- Sine:** 1  $\mu$ Hz to 80 MHz
- Square:** 1  $\mu$ Hz to 80 MHz
- Pulse:** 500  $\mu$ Hz to 50 MHz
- Arb:** 1  $\mu$ Hz to 25 MHz
- Ramp:** 1  $\mu$ Hz to 1 MHz
- Noise (Gaussian):** 50 MHz bandwidth
- Resolution:** 1  $\mu$ Hz; except pulse, 5 digits

#### Accuracy

- Stability:  $\pm 0.3$  ppm, 18° C to 28° C
- Aging:  $\pm 1$  ppm per 1 year

#### Sinewave Spectral Purity

##### Harmonic Distortion:

	$\leq 3$ Vpp <sup>1</sup>	$> 3$ Vpp
DC to 1 MHz	-60 dBc	-55 dBc
1 to 5 MHz	-57 dBc	-45 dBc
5 to 80 MHz	-37 dBc	-30 dBc

**Total Harmonic Distortion:**  $< 0.2\% + 0.1$  mVrms (DC to 20 kHz)

##### Spurious (non-harmonic)<sup>2</sup>:

- DC to 1 MHz: -60 dBc
- 1 to 20 MHz: -50 dBc
- 20 to 80 MHz: -50 dBc + 6 dB/octave

##### Phase noise (30 kHz band):

- 10 MHz:  $< -65$  dBc (typical)
- 80 MHz:  $< -47$  dBc (typical)

#### Signal Characteristics

##### Square

- Rise/Fall Time:**  $< 8$  ns
- Overshoot:**  $< 5\%$
- Asymmetry:** 1% of period + 1 ns
- Duty Cycle:**
  - $\leq 25$  MHz: 20.0% to 80.0%
  - 25 to 50 MHz: 40.0% to 60.0%
  - 50 to 80 MHz: 50.0% fixed

##### Pulse

- Period:** 20.00 ns to 2000.0 s
- Pulse Width:** 8.0 ns to 1999.9 ns
- Variable Edge Time:** 5.00 ns to 1.00 ms
- Overshoot:**  $< 5\%$

##### Ramp

- Linearity:**  $< 0.1\%$  of peak output
- Symmetry:** 0.0% to 100.0%

##### Arb

- Minimum Edge Time:**  $< 10$  ns
- Linearity:**  $< 0.1\%$  of peak output
- Settling Time:**  $< 50$  ns to 0.5% of final value

#### Output Characteristics

**Amplitude** (into 50  $\Omega$ ): 10 mVpp to 10 Vpp

**Accuracy** (at 1 kHz,  $> 10$  mVpp, Autorange):  $\pm 1\%$  of setting  $\pm 1$  mVpp

**Flatness** (sinewave relative to 1 kHz, Autorange):

- $< 10$  MHz  $\pm 1\%$  ( $\pm 0.1$  dB)
- 10 to 50 MHz  $\pm 2\%$  ( $\pm 0.2$  dB)
- 50 to 80 MHz  $\pm 5\%$  ( $\pm 0.4$  dB)

**Units:** Vpp, Vrms, dBm, high and low level

**Resolution:** 0.1 mV or 4 digits

**Offset** (into 50  $\Omega$ ):  $\pm 5$  Vpk ac + dc

**Accuracy:** 1% of setting + 2 mV + 0.5% of amplitude

##### Waveform Output

**Impedance:** 50  $\Omega$  typical (fixed);  $> 10$  M $\Omega$  (output disabled)

**Isolation:** 42 Vpk maximum to earth

**Protection:** short-circuit protected; overload automatically disables main output

#### Modulation

##### AM

- Carrier Waveforms:** sine, square, ramp, and arb
- Modulation Waveforms:** sine, square, ramp, noise, and arb
- Modulation Frequency:** 2 MHz to 20 kHz
- Depth:** 0.0% to 120.0%
- Source:** internal/external

##### FM

- Carrier Waveforms:** sine, square, ramp, and arb
- Modulation Waveforms:** sine, square, ramp, noise, and arb
- Modulation Frequency:** 2 MHz to 20 kHz
- Deviation Range:** DC to 80 MHz
- Source:** internal/external

##### FSK

- Carrier Waveforms:** sine, square, ramp, and arb
- Modulation Waveform:** 50% duty cycle square
- Internal Rate:** 2 MHz to 1 MHz
- Frequency Range:** 1  $\mu$ Hz to 80 MHz
- Source:** internal/external

##### External Modulation Input

- Voltage Range:**  $\pm 5$  V full scale
- Input Impedance:** 10 k $\Omega$
- Frequency:** DC to 20 kHz

#### Burst

- Waveforms:** sine, square, ramp, pulse, arb, and noise
- Frequency:** 1  $\mu$ Hz to 80 MHz ( $> 25$  MHz only with infinite burst count)
- Burst Count:** 1 to 1,000,000 cycles, or infinite
- Start/Stop Phase:**  $-360.0^\circ$  to  $+360.0^\circ$
- Internal Period:** 1 ms to 500 s
- Trigger Source:** single manual trigger, internal, external trigger
- Trigger Delay** (N-cycle, infinite): 0.0 ns to 85.000 s

#### Sweep

- Waveforms:** sine, square, ramp, and arb
- Type:** Linear or logarithmic, up or down
- Start F/Stop F:** 100  $\mu$ Hz to 80 MHz
- Sweep Time:** 1 ms to 500 s
- Trigger:** single manual trigger, internal, external trigger
- Marker:** falling edge of sync signal (programmable)

#### Clock Reference

- Phase Offset:**  $-360.000^\circ$  to  $+360.000^\circ$
- External Reference Input Lock Range:** 10 MHz  $\pm 35$  kHz
- Internal Reference Output Frequency:** 10 MHz

### General Specifications

- State Storage Memory:** Power off state automatically saved; 4 user configurable named stored states.
- Interface:** IEEE-488 and RS-232 standard
- Language:** SCPI-1997, IEEE-488.2
- Power Requirements:** 100-240 V, 50-60 Hz; 100-127 V, 50-400 Hz
- Size:**

- Bench Top: 104 mm H x 254 mm W x 374 mm D (4.16 in x 10.12 in x 14.96 in)
- Rackmount: 89 mm H x 213 mm W x 348 mm D (3.56 in x 8.52 in x 13.92 in)

**Weight:** 4.6 kg (10.12 lb)

**Warranty:** 3 years standard

<http://www.agilent.com/find/waveform>

### Ordering Information

- 33250A** Function/Arbitrary Waveform Generator
  - Opt 1CM** Rackmount kit\*
  - Opt W50** Additional 2-year warranty (5-year total)
- 34131A** Carrying case
- 34161A** Accessory pouch
- 34190A** Rackmount kit\*
- 34811A** BenchLink Arb software

\*For racking two 33250As side-by-side, order the following items:  
Lock-link kit (p/n 5061-9694)  
Flange kit (p/n 5063-9212)

<sup>1</sup> Harmonic distortion at low amplitudes is limited by a -70 dBm floor

<sup>2</sup> Spurious noise at low amplitudes is limited by a -74 dBm floor





- Convenient for lab bench use
- Built-in GPIB programming and measurement
- Continuous and pulse loading operation
- CC, CV, and CR operation
- Multiple input mainframe also available
- Trigger for external synchronization
- Three-year standard warranty



6060B and 6063B

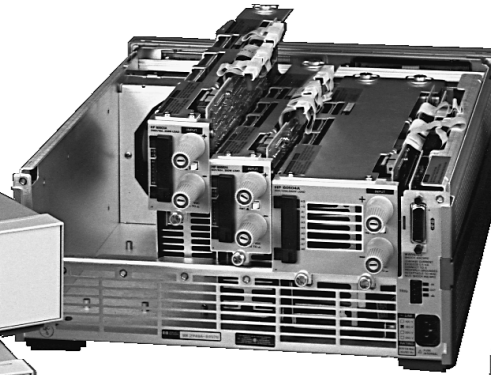

6050A with 60500 Series Modules

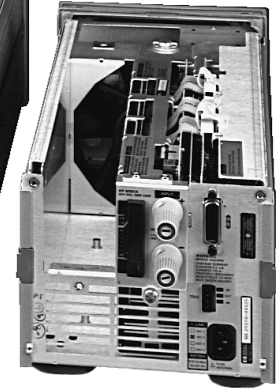

6051A with and 60500 Series Modules

- 6050A
- 6051A
- 6060B
- 6063B
- 60501B to 60507B

### Single Input dc Electronic Loads

The 6060B and 6063B dc electronic loads are suitable for applications where only one input is needed. They are particularly convenient for engineering lab bench use. They have built-in measurement features, so a dmm is not necessary to monitor the output voltage, current or power of the power supply under test.

### Mainframe dc Electronic Loads

This series of dc electronic loads includes a full rack width mainframe and a half rack width mainframe, plus five modules. They have the same features as the single input units, and also provide multiple inputs.

### Ordering Information

- 6050A** Six-slot, 1800 W dc Electronic Load Mainframe
    - Opt 908** Rackmount kit (p/n 5062-3978)
    - Opt 909** Rackmount kit with handles (p/n 5062-3984)
  - 6051A** Two-slot, 600W dc Electronic Load mainframe
    - Opt 800** Rackmount kit for two units mounted side-by-side (p/n 5061-9694 and 5062-3978)
    - Opt 908** Rackmount kit (p/n 5062-3960)
  - 6060B** Single-input, 300 W dc Electronic Load
  - 6063B** Single-input, 250 W dc Electronic Load
    - Opt 020** Front panel inputs
    - Opt 908** Rackmount kit (p/n 5062-3974)
    - Opt 909** Rackmount kit with handles (p/n 5062-3975)
  - 60501B** 150 W dc Electronic Load Module
  - 60502B** 300 W dc Electronic Load Module
  - 60503B** 250 W dc Electronic Load Module
  - 60504B** 600 W dc Electronic Load Module
  - 60507B** 500 W dc Electronic Load Module
- Standard Options**
- Opt 100** 87 to 106 Vac, 47 to 66 Hz (for Japan only)
  - Opt 220** 191 to 233 Vac, 47 to 66 Hz
  - Opt 240** 209 to 250 Vac, 47 to 66 Hz
  - Opt 910** Extra manual set for 6050A, 6051A
- For 6060B, 6063B, 60501-60507

### Abbreviated Technical Specifications

Model	6060B, 60502B	6063B, 60503B	60501B	60504B	60507B
<b>Amperes</b>	0 to 60 A	0 to 10 A	0 to 30 A	0 to 120 A	0 to 60 A
<b>Volts</b>	3 to 60 V	3 to 240 V	3 to 60 V	3 to 60 V	3 to 150 V
<b>Maximum power (at 40° C)</b>	300 W	250 W	150 W	600 W	500 W
<b>Constant current mode</b>					
Ranges	0 to 6 A, 0 to 60 A	0 to 1 A, 0 to 10 A	0 to 3 A, 0 to 30 A	0 to 12 A, 0 to 120 A	0 to 6 A, 0 to 60 A
Accuracy	0.1% ±75 mA	0.15% ±10 mA	0.1% ±40 mA	0.12% ±130 mA	0.1% ±80 mA
Regulation (point)	10 mA	8 mA	10 mA	10 mA	10 mA (w/≥3 V at the point)
<b>Constant voltage mode</b>					
Accuracy	0.1% ±50 mV	0.12% ±120 mV	0.1% ±50 mV	0.1% ±50 mV	0.1% ±125 mV
Regulation (w/remote sense)	10 mV	10 mV	5 mV	20 mV	10 mV
<b>Constant resistance mode</b>					
Ranges	0.033 to 1.0 Ω 1 to 1,000 Ω 10 to 10,000 Ω	0.20 to 24.0 Ω 24 to 10,000 Ω 240 to 50,000 Ω	0.067 to 2 Ω 2 to 2,000 Ω 20 to 10,000 Ω	0.017 to 0.5 Ω 0.5 to 500 Ω 5 to 5,000 Ω	0.033 to 2.5 Ω 2.5 to 2,500 Ω 25 to 10,000 Ω
<b>Readback measurement</b>					
Current accuracy	± (0.05% ±65 mA)	± (0.12% ±10 mA)	± (0.06% ±40 mA)	± (0.1% ±110 mA)	± (0.1% ±65 mA)
Voltage accuracy	± (0.05% +45 mV)	± (0.1% +150 mV)	± (0.5% +45 mV)	± (0.1% +45 mV)	± (0.1% +90 mV)

# DC Electronic Loads

## High Performance Electronic Load Family

N3300A to N3306A

- Accurate programmable control in CC, CV, and CR modes
- Download lists of commands for fast execution
- Continuous and pulse loading
- Synchronize loading and measurement of all inputs
- Analog programming for waveform generation

- Simultaneous measurement of voltage, current, and power
- Synchronize loading and measurements of all inputs
- Waveform digitization
- Parallel units for higher power
- Three-year standard warranty



N3300A

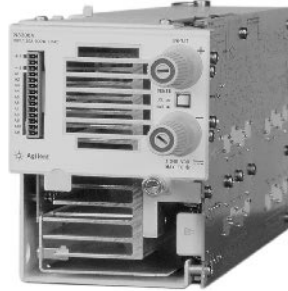

N3306A

### Optimized for High-Volume Manufacturing Test

4

These loads provide many tools to significantly reduce test time of dc power supplies in high-volume manufacturing environments. They execute all commands quicker than any other Agilent Technologies electronic load, and have many additional features to assist in further increasing system throughput. They also have greater accuracy in programming and measurement functions than any other Agilent electronic loads.

### Everything You Need in a One-Box Solution

Agilent electronic loads form an integrated solution, which formerly required more instruments and more complex system configuration.

To monitor the outputs of the power supply under test, a dmm would have had to be switched to each power supply output using a multiplexer. Now, the dmm, the multiplexer, the cabling, and current shunts can all be replaced by the accurate measurement system inside each input of the N3300A Series loads. The built-in digitizer also has can similarly replace an oscilloscope, and associated multiplexer and cabling, for many measurement tasks. The result is a simpler, more reliable, and easier to service test system.

#### Constant Current

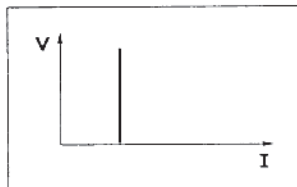

- Power Supply Load Regulation Testing
- Battery Capacity Testing
- Capacitor Discharging

#### Pulse and Dynamic Loading

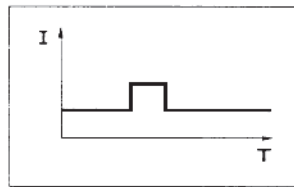

- Power Supply Load Transient Response
- Power Component Testing
- Pulse Electroplating

#### Constant Voltage

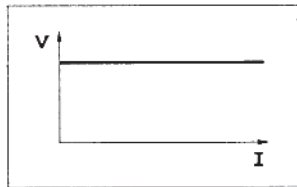

- Current Source Testing
- Current Limit Testing
- Shunt Regulator

#### Programmable Slew Rate

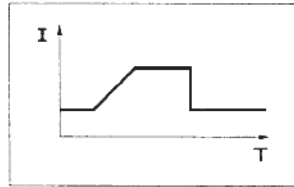

- Power Supply Testing
- Power Component Testing
- Power Supply Load Transient Response
- Program Rising and Falling Rate Separately

#### Constant Resistance

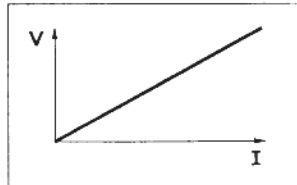

- Characterizing Power Supply Crossover
- Power Supply Start-Up Delay
- Power Resistor Emulation

#### Analog Programming

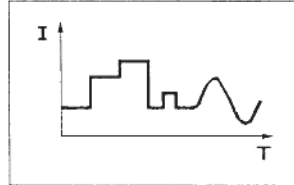

- Battery Capacity Testing
- "Real-life" Load Simulation

## Flexible Programmable Features

GPIO, RS-232, and analog programming are all standard features. These electronic loads are compatible with the industry standard SCPI command set. Most features are also controllable from the front panel, to quickly set up engineering tests on the lab bench. Measurement data can be monitored on the LED front panel display, or read to a computer for further processing.

## Download Program Sequences

A new feature called Lists allows you to download sequences of load input settings to the electronic load. They are then resident in memory, and will execute at maximum rate during runtime. This feature will provide reductions in test time for repetitively executed routines in manufacturing test. Up to four 50-step lists can be stored in non-volatile memory for each load input.

## Powerful Built-in Measurement Features

The input voltage, current, and power of all load inputs can be accurately and simultaneously measured. Up to 4096 samples can be taken and averaged to provide a high level of accuracy and noise immunity. The 4096 long measurement buffer can be used as a digitizer with programmable sample rate. The measurement can be read to the computer as either one averaged number or a 4096 long array. This capability is available for both current and voltage measurements. It is also possible to store multiple measurements in the buffers to be read back to the computer at the completion of a test.

## Mainframe Configuration

The N3300A is a full rack width mainframe. It has six slots. The N3301A is a half rack width mainframe and it has two slots. The 150-, 250- and 300-watt load modules each require one slot. The 500- and 600-watt load modules each require two slots.

## Operation Below Three Volts

Agilent electronic loads meet all specifications when operated above 3V; however, the dc operating characteristics also extend below this minimum input voltage for static tests. The figure below shows the operating range of a typical dc electronic load. Low voltage operation is possible at correspondingly reduced current levels, depending on the minimum resistance of the load. Agilent electronic loads can, therefore, be used in many applications that previously required zero-volt loads. However, transient performance may be degraded.

Another alternative for low voltage operation is to place a three-volt dc power supply in series with the device under test. Then the electronic load would always have at least three volts across it. The N3300A Series of electronic loads has a built-in protection circuit that will protect your power supply under test from being reversed biased by the external boost supply. The external boost power supply must be rated to provide up to the full rated current of the power supply under test.

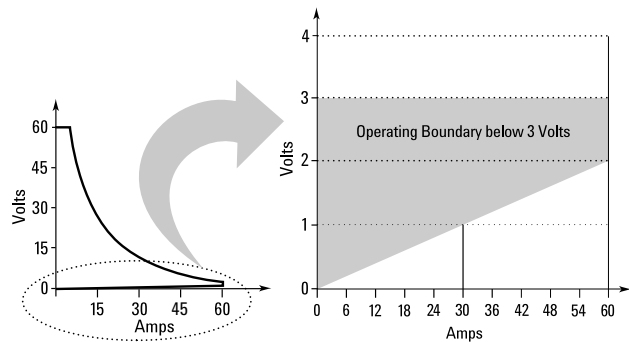

Example of N3304A Input Characteristics

N3300A  
N3301A  
N3302A  
N3303A  
N3304A  
N3305A  
N3306A

## Key Literature

2000/01 Power Products Catalog p/n 5968-2199E

Data Sheet p/n 5980-0232E

Increasing dc Power Supply Test System Throughput with Agilent Technologies N3300A dc Electronic Loads p/n 5980-0233E

## Supplemental Characteristics

### Analog Programming Bandwidth:

10 kHz (-3db frequency)

### Analog Programming Voltage:

Voltage: 0-10V, Current: 0-10V

Analog Monitor Ports:

Voltage: 0-10V, Current: 0-10V

### Remote Sensing: 5 V dc between sense and load input

### Net Weight:

N3300A: 11.8 kg (26 lb); N3301A: 7.8 kg (17 lb)

N3302A, N3303A or N3304A: 3.2 kg (7lb);

N3305A or N3306A: 5.4 kg (13 lb)

### Shipping Weight:

N3300A: 15.9 kg (35 lb); N3301A: 9.8 kg (22 lb)

N3302A, N3303A, or N3304A: 4.5kg (10lb) N3305A or N3306A: 7.3 kg (16 lb)

## Ordering Information

### N3300A 1800 W dc Electronic load Mainframe

**Opt 908** Rackmount kit, p/n 5062-3978

**Opt 909** Rackmount kit w/handles, p/n 5062-3984

### N3301A 600 W Half Rack Width dc Electronic Load Mainframe

**Opt 800** Rackmount kit for two units side-by-side, p/n 5061-9694 and 5062-3978

### N3302A 150 W dc Electronic Load Module

### N3303A 250 W dc Electronic Load Module

### N3304A 300 W dc Electronic Load Module

### N3305A 500 W dc Electronic Load Module

### N3306A 600 W dc Electronic Load Module

# DC Electronic Loads

168

## High Performance Electronic Load Family

### Specifications

	N3302A	N3303A	N3304A	N3305A	N3306A
<b>Amperes</b>	0 to 30 A	0 to 10 A	0 to 60 A	0 to 60 A	0 to 120 A
<b>Volts</b>	3 to 60 V	3 to 240 V	3 to 60 V	3 to 150 V	3 to 60 V
<b>Maximum Power (at 40° C)</b>	150 W	250 W	300 W	500 W	600 W
<b>Constant Current Mode</b>					
Low Range/High Range	3 A/30 A	1 A/10 A	6 A/60 A	6 A/60 A	12 A/120 A
Regulation	10mA	8mA	10mA	10mA	10mA
Low Range Accuracy	0.1% + 5mA	0.1% + 4mA	0.1% + 7.5mA	0.1% + 7.5mA	0.1% + 15mA
High Range Accuracy	0.1% + 10mA	0.1% + 7.5mA	0.1% + 15mA	0.1% + 15mA	0.1% + 37.5mA
<b>Constant Voltage Mode</b>					
Low Range/High Range	6 V/60 V	24 V/240 V	6 V/60 V	15 V/150 V	6 V/60 V
Regulation	5 mV	10mV	10mV	10mV	20mV
Low Range Accuracy	0.1% + 3mV	0.1% + 10mV	0.1% + 3mV	0.1% + 10mV	0.1% + 3mV
High Range Accuracy	0.1% + 8mV	0.1% + 40mV	0.1% + 8mV	0.1% + 20mV	0.1% + 8mV
<b>Constant Resistance Mode</b>					
Range 1	0-4 Ω	0-24 Ω	0-2 Ω	0-5 Ω	0-1 Ω
Range 2	3.6-40 Ω	44-240 Ω	1.8-20 Ω	4.5-50 Ω	0.9-10 Ω
Range 3	36-400 Ω	440-2400 Ω	18-200 Ω	45-500 Ω	9-100 Ω
Range 4	360-2000 Ω	N/A	180-2000 Ω	450-2500 Ω	90-1000 Ω
<b>Transient Generator</b>					
Frequency Range	0.25Hz to 10kHz	0.25Hz to 10kHz	0.25Hz to 10kHz	0.25Hz to 10kHz	0.25Hz to 10kHz
Accuracy	0.5%	0.5%	0.5%	0.5%	0.5%
<b>Duty Cycle Range</b>					
0.25Hz to 1kHz	3% to 97%	3% to 97%	3% to 97%	3% to 97%	3% to 97%
1kHz to 10kHz	6% to 94%	6% to 94%	6% to 94%	6% to 94%	6% to 94%
Accuracy <sup>1</sup>	1%	1%	1%	1%	1%
<b>Measurement</b>					
<b>Current Measurement</b>					
Low Range/High Range	3 A/30 A	1 A/10 A	6 A/60 A	6 A/60 A	12 A/120 A
Low Range Accuracy	0.05% + 3mA	0.05% + 2.5mA	0.05% + 5mA	0.05% + 5mA	0.05% + 10mA
High Range Accuracy	0.05% + 6mA	0.05% + 5mA	0.05% + 10mA	0.05% + 10mA	0.05% + 20mA
<b>Voltage Measurement</b>					
Low Range/High Range	6 V/60 V	24 V/240 V	6 V/60 V	15 V/150 V	6 V/60 V
Low Range Accuracy	0.05% + 3mV	0.05% + 10mV	0.05% + 3mV	0.05% + 8mV	0.05% + 3mV
High Range Accuracy	0.05% + 8mV	0.05% + 20mV	0.05% + 8mV	0.05% + 16mV	0.05% + 8mV
<b>Power Measurement</b>					
Accuracy	0.1% + 0.5 W	0.1% + 1.2 W	0.1% + 0.5 W	0.1% + 1.5 W	0.1% + 1.2 W

<sup>1</sup>Duty cycle accuracy is 1%. For example, if the setting is 40% duty cycle, the actual duty cycle would be in the range of 39%-41%.

### Supplemental Characteristics

<b>Programming Resolution</b>					
Constant Current Mode	0.05mA/0.5mA	0.02mA/0.2mA	0.1 mA /1mA	0.1mA/1 mA	0.2 mA/2 mA
Constant Voltage Mode	0.1mV/1mV	0.4 mV / 4mV	0.1 mV/1 mV	0.25mV/2.5mV	0.1mV/1mV
Constant Resistance Mode	0.07/0.7/7/70m Ω	0.82/8.2/82m Ω	0.035/0.35/3.5/35m Ω	0.085/0.85/8.5/85m Ω	0.0175/0.175/1.75/17.5m Ω
<b>Readback Resolution</b>					
Current	0.05mA/0.5mA	0.02mA/0.2mA	0.1 mA/1mA	0.1mA/1 mA	0.2 mA/2 mA
Voltage	0.1mV/1mV	0.4 mV/4mV	0.1 mV/1mV	0.25mV/2.5mV	0.1mV/1mV
<b>Programmable Slew Rate</b>					
Current	0.2A/ms to 2.5A/μs	0.017A/ms to 0.83A/μs	0.1A/ms to 5A/μs	0.1A/ms to 5A/μs	0.2A/ms to 10A/μs
Voltage	0.1V/ms to 0.5V/μs	1V/ms to 2V/μs	0.1V/ms to 0.5V/μs	1V/ms to 1.25V/μs	0.1V/ms to 0.5V/μs
<b>Ripple and Noise (20 Hz to 10 MHz)</b>					
Current	2mA rms 20mA p-p	1mA rms 10mA p-p	4mA rms 40mA p-p	4mA rms 40mA p-p	6mA rms 60mA p-p
Voltage	5 mV rms	12mV rms	6mV rms	10mV rms	8mV rms

Note: Specifications subject to change.

\* Special modifications are available to change input voltage, current, and accuracy specifications. Please ask.

1. Operating temperature range is 0° C to 55° C. All specifications apply for 25° C ±5° C unless otherwise noted

2. Maximum continuous power available is derated linearly from 40° C to 75% of maximum at 55° C.

3. DC Current Accuracy specifications apply 30 seconds after input is applied.



### GPIB System Power Supplies Single Output

Max. volts (dc)	Max. amps (dc)	Max. watts	Output Operating Boundary	Model Number	Page
5	875	4400	Rectangular	6680A	184
6.7	30	200	Autoranging	6033A	185
7	120	1000	Autoranging	6031A	185
8	5	40	Rectangular	6611C	178
8	10	80	Rectangular	6631B	180
8	20	160	Rectangular	6641A	181
8	50	400	Rectangular	6651A	182
8	220	1760	Rectangular	6671A	183
8	580	4600	Rectangular	6681A	184
15	3	45	Rectangular	66311B/D	173
15/12	3/1.5	45/18	Rectangular	66309B/D	173
20	2	40	Rectangular	6612B	178
20	2	40	Rectangular	66312A	177
20	5	100	Rectangular	6632B	180
20	5	100	Rectangular	66332A	177
20	10	200	Autoranging	6033A	185
20	10	200	Autoranging	6038A	185
20	10	200	Rectangular	6642A	181
20/8	1.5/3	30	Dual Range	E3640A	187
20/8	2.5/5	50	Dual Range	E3642A	187
20/8	4/8	80	Dual Range	E3644A	187
20/8	10/20	200/160	Dual Range	E3633A	189
20	25	500	Rectangular	6652A	182
20	50	1000	Autoranging	6031A	185
20	50	1200	Autoranging	6032A	185
20	100	2000	Rectangular	6672A	183
21	240	5000	Rectangular	6682A	184
30/15	4/7	120/105	Dual Range	E3632A	189
32	160	5100	Rectangular	6683A	184
35	6	210	Rectangular	6643A	181
35	15	525	Rectangular	6653A	182
35	60	2100	Rectangular	6673A	183
40	128	5100	Rectangular	6684A	184
50	1	50	Rectangular	6613C	178
50	2	100	Rectangular	6633B	180
50/25	4/7	200/175	Dual Range	E3634A	189
60/35	0.5/0.8	30	Dual Range	E3641A	187
60	3.3	200	Autoranging	6038A	185
60	3.5	210	Rectangular	6644A	181
60	9	540	Rectangular	6654A	182
60	17	1200	Autoranging	6030A	185
60	17.5	1200	Autoranging	6032A	185
60	30	150	Rectangular	60501B	166
60	35	2100	Rectangular	6674A	183
60	60	300	Rectangular	6060B	166
60	60	300	Rectangular	60502B	166
60	120	600	Rectangular	60504B	166
65	8	480	Rectangular	E4350B	176
80	30	2100	Rectangular	E4356A	166
100	0.5	50	Rectangular	6614C	178
100	1	100	Rectangular	6634B	180
120	1.5	180	Rectangular	6645A	181
120	4	540	Rectangular	6655A	182
120	18	2160	Rectangular	6675A	183
130	4	480	Rectangular	E4351B	176
150	60	500	Rectangular	60507B	166
200	5	1000	Autoranging	6035A	185
200	5	1200	Autoranging	6030A	185
240	10	250	Rectangular	6063B	166
240	10	250	Rectangular	60503B	166
500	2	1000	Autoranging	6035A	185

### Available on Special Order Single Output 100 to 5000 watts per output

Max. volts (dc)	Max. amps (dc)	Max. watts	Output Operating Boundary	Model Number
4	1000	4000	Rectangular	6680A-J03
5	250	1000	Rectangular	6671A-J14
6	60	360	Rectangular	6651A-J03
8	250	2000	Rectangular	6671A-J05
10	50	500	Rectangular	6651A-J01
10	200	2000	Rectangular	6671A-J04
14	150	2000	Rectangular	6671A-J03
15	30	450	Rectangular	6651A-J05
15	120	1800	Rectangular	6671A-J17
18	280	5000	Rectangular	6682A-J01
24	85	2000	Rectangular	6672A-J04
30	3.3	100	Rectangular	66332A-J01
30	17.5	500	Rectangular	6653A-J17
30	65	2000	Rectangular	6673A-J09
32	16	500	Rectangular	6653A-J16
36	15	500	Rectangular	6653A-J09
36	55	2000	Rectangular	6673A-J04
37.5	45	1700	Rectangular	6673A-J03
38	55	2000	Rectangular	6673A-J07
40	5	200	Rectangular	6643A-J11
40	12.5	500	Rectangular	6653A-J04
40	50	2000	Rectangular	6673A-J08
42	12	500	Rectangular	6654A-J29
42	10	500	Rectangular	6654A-J05
42	2000	Rectangular	6674A-J07	
50	100	5000	Rectangular	6684A-V50
55	38	2000	Rectangular	6674A-J03
70	3	200	Rectangular	6644A-J09
70	7.5	500	Rectangular	6654A-J04
70	30	2000	Rectangular	6674A-J06
80	6	500	Rectangular	6654A-J12
80	26	2000	Rectangular	6674A-J05 <sup>1</sup>
100	22	2000	Rectangular	6675A-J08
110	20	2000	Rectangular	6675A-J09
135	16	2000	Rectangular	6675A-J06
150	1.2	150	Rectangular	6645A-J05
150	3.2	500	Rectangular	6655A-J05
150	15	2000	Rectangular	6675A-J11
156	3	500	Rectangular	6655A-J10
160	13	2000	Rectangular	6675A-J04
200	11	2000	Rectangular	6675A-J07

<sup>1</sup>Order standard product E4356A

### Key Literature

2000/01 Agilent Power Products Catalog, p/n 5968-2199E

For more information, visit our web site:  
<http://www.agilent.com/find/power>

### Multiple Output

Range 1		Range 2		Outputs for each model number										
Max. volts (dc)	Max. amps (dc)	Max. volts (dc)	Max. amps (dc)	Max. watts output	6621A page 179	6622A page 179	6623A page 179	6624A page 179	6625A page 179	6626A page 179	6627A page 179	6628A page 179	6629A page 179	E3631A page 189
6	5	—	—	—	—	—	—	—	—	—	—	—	—	Output 3
7	0.015	50	0.5	25	—	—	—	—	Output 1	Outputs 1–2	—	—	—	—
7	5	20	2	40	—	—	Output 1	Outputs 1–2	—	—	—	—	—	—
7	10	20	4	80	Outputs 1–2	—	Output 3	—	—	—	—	—	—	—
8	20	20	10	200	—	—	—	—	—	—	—	—	—	—
15	7	30	4	120	—	—	—	—	—	—	—	—	—	—
16	0.2	16	2	50	—	—	—	—	Output 2	Outputs 3–4	—	Outputs 1–2	Outputs 1-4	—
16	0.2	50	1	50	—	—	—	—	Output 2	Outputs 3–4	—	Outputs 1–2	Outputs 1-4	—
20	2	50	0.8	40	—	—	Output 2	Outputs 3–4	—	—	Outputs 1-4	—	—	—
20	4	50	2	100	—	Outputs 1–2	—	—	—	—	—	—	—	—
±25	1	—	—	25	—	—	—	—	—	—	—	—	—	Outputs 1–2
<b>Output Operating Boundary</b>				Rectangular										

# Power Supplies

170

## Selection Index (cont.)

Overview

### Manually-Controlled and Analog-Programmable Power Supplies

#### Single Output

Max. volts (dc)	Max. amps (dc)	Max. watts	Type	Manually controlled analog-prog	Model Number	Page
6.7	30	200	Autoranging	MC/AP	6023A	185
7	120	840	Autoranging	MC/AP	6011A	185
8	6	48	Rectangular	MC/AP	E3614A	191
8	20	160	Rectangular	MC/AP	6541A	181
8	50	400	Rectangular	MC/AP	6551A	182
8	220	1760	Rectangular	MC/AP	6571A	183
15/8	2/3	30	Dual-range	MC	E3610A	191
20	3	60	Rectangular	MC/AP	E3615A	191
20	10	200	Autoranging	MC/AP	6023A	185
20	10	200	Autoranging	MC/AP	6024A	185
20	10	200	Rectangular	MC/AP	6542A	181
20	25	500	Rectangular	MC/AP	6552A	182
20	50	1000	Autoranging	MC/AP	6011A	185
20	50	1000	Autoranging	MC/AP	6012B	185
20	100	2000	Rectangular	MC/AP	6572A	183
35/20	0.85/1.5	30	Dual-range	MC	E3611A	191
35	1.7	60	Rectangular	MC/AP	E3616A	191
35	6	210	Rectangular	MC/AP	6543A	181
35	15	525	Rectangular	MC/AP	6553A	182
35	60	2100	Rectangular	MC/AP	6573A	183
40	5.7	228	Autoranging	MC/AP	6028A	185
40	30	1200	Autoranging	MC/AP	6012B	185
60	1	60	Rectangular	MC/AP	E3617A	191
60	3.3	200	Autoranging	MC/AP	6028A	185
60	3.5	210	Rectangular	MC/AP	6544A	181
60	9	540	Rectangular	MC/AP	6554A	182
60	17	1020	Autoranging	MC/AP	6010A	185
60	17.5	1050	Autoranging	MC/AP	6012B	185
60	35	2100	Rectangular	MC/AP	6574A	183
120/60	0.25/0.5	30	Dual-range	MC	E3612A	191
120	1.5	180	Rectangular	MC/AP	6545A	181
120	4.5	540	Rectangular	MC/AP	6555A	182
120	18	2160	Rectangular	MC/AP	6575A	183
200	5	1000	Autoranging	MC/AP	6010A	185
200	5	1000	Autoranging	MC/AP	6015A	185
500	2	1000	Autoranging	MC/AP	6015A	185

#### Multiple Output

Max. volts (dc)	Max. amps (dc)	Max. watts per output	Outputs for each model number	
			E3620A MC Page 190	E3630A MC Page 190
6	2.5	15		Output 1
±20	0.5	10		Outputs 2 & 3
25	1	25	Outputs 1 & 2	

\*MC=Manually controlled. AP=Analog programmable.

#### Single Output

Available on Special Order

Max. volts (dc)	Max. amps (dc)	Max. watts	Output Operating Boundry	Manually controlled analog-prog	Model Number
10	200	2000	Rectangular	MC/AP	6571A-J04
13	15.3	200	Rectangular	MC/AP	6541A-J04
14	150	2000	Rectangular	MC/AP	6571A-J03
30	65	2000	Rectangular	MC/AP	6573A-J09
35	8	280	Rectangular	MC/AP	6553A-J21
36	55	2000	Rectangular	MC/AP	6573A-J04
37.5	45	1500	Rectangular	MC/AP	6573A-J03
40	50	2000	Rectangular	MC/AP	6673A-J08
40	5	200	Rectangular	MC/AP	6543A-J11
50	42	2000	Rectangular	MC/AP	6574A-J07
55	38	2000	Rectangular	MC/AP	6574A-J03
70	7.5	500	Rectangular	MC/AP	6554A-J04
70	30	2000	Rectangular	MC/AP	6574A-J06
100	22	2000	Rectangular	MC/AP	6575A-J08
110	20	2000	Rectangular	MC/AP	6675A-J09
135	16	2000	Rectangular	MC/AP	6575A-J06
150	1.2	150	Rectangular	MC/AP	6545A-J05
150	3	500	Rectangular	MC/AP	6555A-J10
160	13	2000	Rectangular	MC/AP	6675A-J04
200	11	2000	Rectangular	MC/AP	6575A-J07

For more information, visit our web site:  
<http://www.agilent.com/find/power>

#### Modules for 66000 Modular Power System

Up to 8 per mainframe

Max. volts (dc)	Max. amps (dc)	Max. watts	Model Number	Page
8	16	128	66101A	171
20	7.5	150	66102A	171
35	4.5	150	66103A	171
60	2.5	150	66104A	171
120	1.25	150	66105A	171
200	0.75	150	66106A	171

Available on Special Order

Max. volts (dc)	Max. amps (dc)	Max. watts	Model Number
5.7	20	100	66101A-J03
12	12	150	66101A-J03
15	10	150	66102A-J05
24	6	100	66103A-J12
28	5	1400	66103A-J09
35	1.25	40	66105A-J01
37	4	150	66103A-J01
40	3.6	100	66103A-J02

- High density 1200W mainframe in 7 inches of rack space
- 8-slot modular power system
- Stable, low ripple and noise power source
- High-accuracy readback of voltage and current
- Advanced programmable voltage and current control
- Sequence up to 20 voltage and current setting per output
- Optional isolation and polarity-reversal relays
- Three-year standard warranty



66000A  
66001A  
66101A  
to 66106A

### 66000 Modular Power System



66000 Modular Power System is ideal for automated testing environments for supplying bias power and stimulus to subassemblies and final products.

#### Key Features

- GPIB programmable voltage and current
- Series and parallel operation
- Programmable over-voltage and over-current protection
- Self-test initiated at power-up or from GPIB command
- Electronic calibration over GPIB or from keyboard
- Over-temperature protection
- Discrete fault indicator/remote inhibit (DFI/RI)
- Five nonvolatile store-recall states per output
- User-definable power-on state

### Abbreviated Specification and Characteristics (Specifications at 0° C to 55° C unless otherwise noted)

		66101A	66102A	66103A	66104A	66105A	66106A
<b>Output ratings</b> (at 40° C)	Output Voltage	0 to 8 V	0 to 20 V	0 to 35 V	0 to 60 V	0 to 120 V	0 to 200 V
	Output Current	0 to 16 A	0 to 7.5 A	0 to 4.5 A	0 to 2.5 A	0 to 1.25 A	0 to 0.75 A
	Output Power	128 W	150 W	150 W	150 W	150 W	150 W
<b>Programming accuracy</b> (at 25° C ±5° C)	Voltage 0.03%+	3 mV	8 mV	13 mV	27 mV	54 mV	90 mV
	Current 0.03%+	6 mA	3 mA	2 mA	1.2 mA	0.6 mA	0.4 mA
<b>Readback accuracy</b> (via GPIB or keyboard display at 25° C ±5° C)	Voltage 0.02%+	2 mV	5 mV	8 mV	16 mV	32 mV	54 mV
	Current 0.02%+	6 mA	3 mA	2 mA	1 mA	0.6 mA	0.3 mA
<b>Ripple and noise</b> (20 Hz to 20 MHz)	Constant voltage rms	2 mV	3 mV	5 mV	9 mV	18 mV	30 mV
	peak to peak	5 mV	7 mV	10 mV	15 mV	25 mV	50 mV
	Constant current rms	8 mA	4 mA	2 mA	1 mA	1 mA	1 mA
<b>Line Regulation</b>	Voltage	0.5 mV	0.5 mV	1 mV	2 mV	3 mV	5 mV
	Current	0.75 mA	0.5 mA	0.3 mA	0.1 mA	50 μA	30 μA
<b>Load Regulation</b>	Voltage	1 mV	1 mV	1 mV	2 mV	4 mV	7 mV
	Current	0.5 mA	0.2 mA	0.2 mA	0.1 mA	50 μA	10 μA
<b>Transient Response Time:</b> Less than 1 ms for the output voltage to recover within 100 mV of its previous level following any step change in load current up to 10 percent of rated current							
<b>Average resolution</b>	Voltage	2.4 mV	5.9 mV	10.4 mV	18.0 mV	36.0 mV	60.0 mV
	Current	4.6 mA	2.3 mA	1.4 mA	0.75 mA	0.39 mA	0.23 mA
	Output voltage Programming (OVP)	50 mV	120 mV	200 mV	375 mV	750 mV	1.25 V
<b>OVP accuracy</b>		250 mV	500 mV	800 mV	1 V	1.5 V	2.5 V

**dc Floating Voltage:** Output terminals can be floated up to ±240 Vdc from chassis ground

**Remote Sensing:** Up to half the rated output voltage can be dropped across each load lead. Add 2 mV to the voltage load regulation specification for each 1-V change in the negative output lead caused by a load current change.

**Command Processing Time:** The average time for the output voltage to change after getting a GPIB command is 20 ms

**Output Programming Response Time** (with full resistive load): The rise time (10/90%) of the output voltage is less than 20 ms. The fall time (90/10%) of the output voltage is less than 20 ms (66101A–66103A) or 50 ms for (66104A–66105A). The output voltage change settles within 0.1% of the final value in less than 120 ms.

**Down Programming:** An active down-programmer sinks approximately 10% of the rated output current

**Calibration Interval:** One year

#### ac Input of System Mainframe

<b>Voltage</b>	100 Vac	120 Vac	200 Vac	220 Vac	230 Vac	240 Vac
<b>Maximum current</b>	29 A	25 A	16 A	16 A	15 A	15 A

**Input Power of System Mainframe:** 3200 VA (max.), 1800 W (max.), 1600 W (typ.)

**Regulatory Compliance:** Listed to UL-1244; certified to CSA 22.2 No. 1010.1; complies with EN61010-1, carries the CE mark

**RFI Suppression:** Complies with CISPR-11, Group 1, Class A

#### Weight:

**Net:** 66000A, 15 kg (33 lb); 66001A, 1.05 kg (2.3 lb); 66101–66106A, 2.7 kg (6 lb).

**Shipping:** 66000A, 19 kg (41 lb); 66001A, 1.34 kg (2.95 lb); 66101–66106A, 4.1 kg (9 lb).

**Size:** 66000A: 192 mm H x 425.7 mm W x 677.93 mm D

(7.28 in x 16.76 in x 26.69 in), including feet and rear connectors

**Warranty Period:** Three years

#### Key Literature

2000/01 Agilent Power Products Catalog, p/n 5968-2199E  
66000 Modular Power System Product Note, p/n 5091-2497E

For more information, visit our web site:

<http://www.agilent.com/find/modularPS>

66000A  
66001A  
66101A  
to  
66106A



## Advanced Programmable Control for Increased Throughput

66000 MPS features a powerful output capability, precise control of voltage and current, programmable protection features, user-definable power-on state, and five non-volatile store-recall states per output. An optional keyboard offers full control of all programmable features. GPIB interface is a standard feature fully compatible with the industry-standard SCPI command set.

Increase test throughput by using the output sequencing feature of the 66000 MPS. This powerful feature allows you to download up to 20 voltage, current, and dwell-time parameter sets per output. This sequence can be paced by the programmed dwell times. As an alternative, triggers can be used to step through the output list. The output sequences can be executed without controller intervention, thereby increasing overall test system throughput.

## Ordering Information

### 66000A MPS Mainframe

**Opt 908** Rackmount Kit (p/n 5062-3978)

**Opt 909** Rackmount Kit with Handles  
(p/n 5062-3984)

**Note: Options 908 and 909** require cabinet rails (p/n E3663AC) or a slide kit (p/n 1494-0059) to support the loaded mainframe's weight.

**Opt 910** Extra Manual Set (Standard unit is shipped with Installation Guide only.)

**66001A** MPS Keyboard includes 2m (6 ft) cables

**66002A** Rack Kit for 66001A keyboard

### Module Options

**66101A** dc Power Module 8 V, 16 A

**66102A** dc Power Module 20 V, 7.5 A

**66103A** dc Power Module 35 V, 4.5 A

**66104A** dc Power Module 60 V, 2.5 A

**66105A** dc Power Module 120 V, 1.25 A

**66106A** dc Power Module 200 V, 0.75 A

**Opt 760** Open/Close and Polarity Reversal Relays

**Opt 910** Extra Manual Set: User's Guide, Programming Guide and Service Manual (Standard unit is shipped with Installation Guide only.)

### Accessories

p/n 5060-3351 Field-Installable Relay Kit

p/n 5060-3386 Standard Connector Assembly

p/n 5060-3387 Standard Connector Assembly with installed relays (Option 760)

p/n 66000-90001 Mainframe Installation Guide

p/n 5959-3386 dc Power Module User's Guide

p/n 5959-3362 dc Power Module Programming Guide

p/n 66000-90003 Mainframe Service Manual

p/n 5959-3364 dc Power Module Service Manual

p/n 1252-1488 4-Pin FLT/Inhibit Connector

### Line Cord Options

A line cord option must be specified. For details, refer to page 186.

4

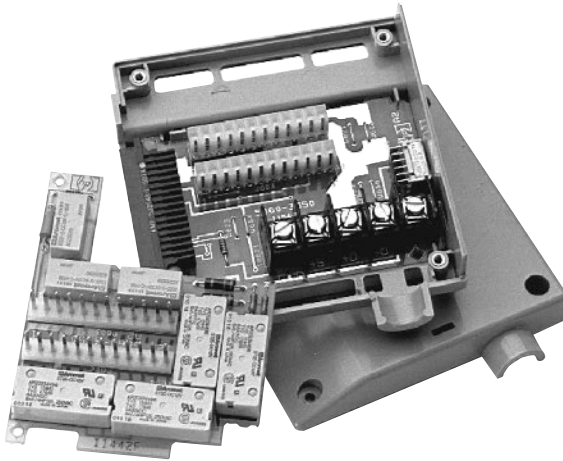

Isolation and polarity reversal relays are available as an option to the modules. The relay assembly fits into the module connector and can be fully controlled and sensed over the GPIB.

## Simple Way to Integrate Multiple Power Sources

The Agilent serial link feature will allow you to control up to 16 outputs at one GPIB address by connecting an auxiliary mainframe. The serial link cable comes standard with the 66000 MPS mainframe. For applications with a broader range of power requirements, one 66000 mainframe can be connected with up to eight of the 6640, 6650, 6670, 6680, or 6030 series of system power supplies. This solution provides power ranges from 150 watts to 5,000 at one primary GPIB address.

System assembly is simplified thanks to a quick-disconnect connector assembly on each module. Once your wires are connected to the load, the connector design permits the modules to be removed from the front of the mainframe without disconnecting cabling or removing the mainframe from the rack. One connector assembly is shipped with each module.

## No Compromise Performance with Modular Convenience

66000 MPS offers high performance and reliability and the advantages of modularity. The 66000 MPS offers high stability for applications that need precise output control, accurate readback measurements, and low output noise.



- 5A peak current
- Single and dual output models
- Fast transient voltage response
- Precision  $\mu\text{A}$  measurement
- Dynamic current pulse measurement
- Exceptional sourcing and current sinking
- Automatic detection of open sense connections
- VXI *plug&play* drivers
- Programmable output resistance (66319B/D, 66321B/D)



66319D

### Solutions for Testing Battery-Powered Devices

Agilent's mobile communications dc sources are a family of 45 watt power supplies that functions as a power-source alternative to batteries and charger for testing mobile phones and portable devices. They offer up to 5 A peak current sourcing with improved output stability and superior voltage transient response, Fast Response Power Technology, that prevents device shutdowns due to significant voltage drops in the test wiring.

### 66319B/D, 66321B/D with Battery Emulation NEW

Four new models, the 66319B, 66319D, 66321B, and 66321D have been added to this family of specialized dc power supplies. These new high performance models offer all the capabilities of the existing Mobile Communications dc Sources, plus they provide the following capabilities:

- Battery emulation (programmable output resistance)
- Very low transient voltage drop (typically  $<25\text{mV}$ )
- Excellent output stability for either short or long load leads up to 6 meters
- Four programmable compensation modes to optimize output performance
- Programmable over-voltage soft limits to protect device under test

The new programmable output resistance capability allows you to test your phones under the same power conditions as in actual use; detecting early product failures. These new models can simulate the effects of the internal resistance in a battery, enabling them to accurately emulate the operation of various battery types, as well as batteries nearing end of life. Additionally, they provide the ability to simulate negative resistance that lets you compensate for the voltage drop in the wiring between the test fixture and battery contacts in the cell phone.

### A rack's worth of capability in a single box

From the dual output 66319D with battery emulation and built-in DVM to the 66311A, this family of solutions offers many capabilities in a single, half-rack box. They eliminate the cost and hassle of integrating and using oscilloscope or high-speed digital voltmeter, shunts, relays and multiplexers to make voltage and current measurements. Now you can catch and characterize those critical pulses using only a power supply.

In addition to dynamic measurements, the mobile communications dc source solutions feature output programming response as fast as  $400\mu\text{s}$  and command processing times of less than 4ms; the reduced cycle times will boost your test throughput, too.

### Maintaining Value

With a full set of device protection features and three-year warranties, the mobile communications dc source solutions will keep delivering superb results year after year. A new Agilent-developed technology that automatically detects open sense connections helps ensure you deliver quality products to your customers.

### Simplify Test & Analysis

With the 14565A Device Characterization Software (Option 052), testing, analyzing, and, troubleshooting mobile phone design and subsystem is made simple. The optional 14565A graphical user interface lets you easily control these power supplies. Plus it provides an oscilloscope-like view of the voltage or current waveform of the device under test, provides reference waveform save/recall, and oscilloscope-like waveform measurement and analysis (current or voltage measurements, triggering, markers, zoom control, and more).

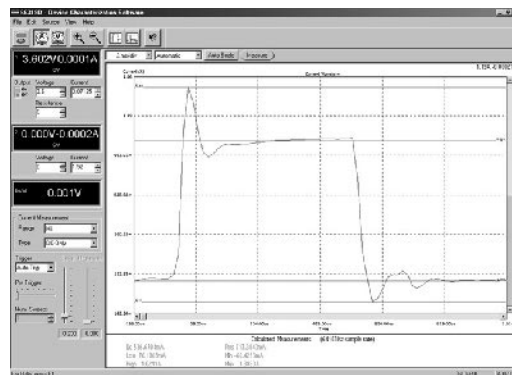

### Ordering Information

**Standard: 104 to 127 Vac 47 to 63 Hz**

**Opt 100** 87 to 106 Vac, 47 to 63 Hz

**Opt 220** 191 to 233 Vac, 47 to 63 Hz

**Opt 230** 207 to 253 Vac, 47 to 63 Hz

**Opt 052** 14565A Device Characterization Software

**Opt 521** Solid State relays (66309B/D and 66319 B/D only)

**Opt 1CM** Rack-mount Kit p/n 5063-9240

**Opt AXS** Rack-mount Kit for side-by-side mounting, Locking Kit p/n 5061-9494; Flange Kit p/n 5063-9212

**Opt OBN** Service Manual, extra User's Guide and Programming Guide

66309B  
66309D  
66311B  
66311D  
66319B  
66319D  
66321B  
66321D

## Abbreviated Specifications and Characteristics

Model		66311B 66311D	66309B 66309D	66319B <sup>new</sup> 66319D	66321B <sup>new</sup> 66321D
<b>Number of Outputs</b>		1	2 <b>Output 1</b>	2 <b>Output 1</b>	1
<b>Output Ratings</b>	Voltage	0 to 15 V	0 to 15 V	0 to 12 V	0 to 12 V
	Current	0 to 3 A 5A <sup>1</sup>	0 to 3 A 5A <sup>1</sup>	0 to 1.5 A 2.5A <sup>2</sup>	0 to 1.5 A 2.5A <sup>2</sup>
<b>Programming accuracy</b> At 25° C ±5° C	Voltage	0.05% + 10 mV	0.05% + 10 mV	0.05% + 10 mV	0.05% + 10 mV
	Current	0.05% + 1.33 mA	0.05% + 1.33 mA	0.2% + 4.5 mA	0.2% + 4.5 mA
<b>Ripple and Noise</b> (20 Hz to 20 MHz)	Voltage (rms/p-p)	1 mV/ 6 mV <sup>3</sup>	1 mV/ 6 mV <sup>3</sup>	1 mV/ 6 mV <sup>3</sup>	1 mV/ 6 mV <sup>3</sup>
	Current (rms)	2 mA	2 mA	2 mA	2 mA
<b>dc Measurement Accuracy</b> (via GPIB or front panel meters with respect to actual output at 25° C ±5° C)	Voltage	0.03% + 5 mV	0.03% + 5 mV	0.02% + 15 mV	0.03% + 5 mV
	Current	see below	see below	0.2% + 3 mA	see below
	High Current Range +3 A to +5 A	0.2% + 0.5 mA <sup>4</sup>	0.2% + 0.5 mA <sup>4</sup>	–	0.2% + 0.5 mA
	+20 mA to + rated I	0.2% + 1.1 mA	0.2% + 1.1 mA	–	–
	–20 ma to – rated I	–	–	–	–
	Medium Current Range –1 A to +1 A	–	–	–	0.1% + 0.2 mA
Low Current Range –20 mA to +20 mA	0.1% + 2.5 uA	0.1% + 2.5 uA	–	0.1% + 2.5 uA	
<b>Transient Response Time</b>		<35 us <sup>5</sup>	<35 us <sup>5</sup>	<400 us <sup>5</sup>	<400 us <sup>5</sup>
<b>Programmable Output Resistance</b>	Range	–	–	–0.04 to 1 Ω	–0.04 to 1 Ω
	Resolution	–	–	0.001 Ω	0.001 Ω
	Accuracy	–	–	0.5% + 2 mΩ	0.5% + 2 mΩ
		66311B 66311D	66309B 66309D	66319B 66319D	66321B 66321D

<sup>1</sup>Peak current for up to a 7 ms time period. Average current cannot exceed 3 A  
<sup>2</sup>Peak current for up to a 1 ms time period. Average current cannot exceed 1.5 A  
<sup>3</sup>For phone capacitance higher than 6 uF  
<sup>4</sup>Applies with current detector set to dc

<sup>5</sup>Time for the output voltage to recover to within 20 mV of its final value following a 0.1 A to 1.5 A load change in the High Mode compensation range  
<sup>6</sup>Time for the output voltage to recover to within 20 mV of its final value following a 0.75 A to 1.5 A load change

### Voltmeter Input (66309D, 66311D, 66319D, and 66321D only)

<b>Input Range</b>	Max differential voltage between input terminals ±25V
<b>dc Readback Accuracy</b> At 25 deg C +/- 5 deg C	0.04% + 5 mV
<b>(ac + dc) rms Readback Accuracy</b> @25° C ± 5° C with dc plus a sinewave input >25 mV rms	1% + 5 mV at 10 K Hz sinewave 60 Hz to 10 KHz: 1% + 5 mV <sup>1</sup> 45-60 Hz and 10-20 KHz: 4% + 5 mV <sup>1</sup>
<b>Common Mode Voltage Range</b> (from either DVM input with respect to the negative output terminal of Output #1)	–4.5 V pk to 25 V pk

<sup>1</sup>1+15 mV for dc plus sinewave input <25 mV rms

**dc Floating Voltage:** Output terminals can be floated up to ±50 Vdc maximum from chassis ground.

**Remote Sensing:** Up to 4 V can be dropped across each load lead, add 2 mV to the voltage load regulation specification for each 1 V change in the positive output lead due to load current change. For the auxiliary output on the 66319B/D, 66321B/D add 3 V to the voltage load regulation for each 1 V change in the negative output lead.

**Command Processing Time:** Average time required for the output voltage to begin to change following receipt of digital data is 4 ms for the power supplies connected directly to the GPIB. (Display disabled.)

**Output Programming Response Time:** The rise and fall time (10/90% and 90/10%) of the output voltage for 66311B/D, 66321B/D, Output 1-66309B/D, 66319B/D is <200 μs. The output voltage change settles within 1 LSB (0.025% x rated voltage) of final value in 2 ms.

**Measurement Time:** Average time to process query, calculate measure-

ment parameter and return data is 50 ms (includes the default time of 30 ms for acquiring data, and a 20 ms data processing overhead).

**GPIB Interface Capabilities:** IEEE-488.2, SCPI command set, and 6630A series programming capability (except 66309B/D, 66319B/D, 66321B/D).

**Input (full load):** 47–63 Hz @ 100 Vac mains: 66311B/D, 66321B/D: 1.7 A, 125 W; 66309B/D, 66319B/D: 2 A, 170 W.

**Regulatory Compliance:** Complies with EMC directive 89/336/EEC (ISM 1B). List pending to UL 3111-1.

**Warranty Period:** 3 years.

**Size:** 66309B/D, 66311B/D, 66319B/D, 66321B/D:

88.1 mm H x 212.8 mm W x 435 mm D (3.5 in x 8.4 in x 17.13 in).

**Weight:** 66309B/D, 66311B/D, 66319B/D, 66321B/D: 9.07 kg (20 lb) net, 11.1 kg (24.5 lb) shipping.

- Low ripple and noise
- Fast up – and down – programming
- SCPI (Standard Commands for Programmable Instruments)
- Complete front-panel control, calibration and display
- Remote programming and sensing
- Fan-speed control to minimize acoustic noise
- Over-voltage and over-current protection
- VXI plug&play drivers
- Also suitable for non-telecom applications



E4356A

### E4356A Telecom dc Power Supply

The E4356A telecom dc power supply is a one-box solution that delivers the reliable capabilities of an integrated system. This power supply provides power at up to 80 Vdc and up to 30 A in two ranges. When programmed to operate between 0 V and 70 V, the E4356A is automatically placed in the low output range, offering its full 30 A maximum current and 2100 W. When programmed between 70 V and 80 V, the E4356A switches into the high output range, where it is able to provide up to 26 A and 2100 W. Thus, the E4356A's automatic ranging means that you get the most power possible, whether you are operating at 70 V or 80 V.

Since noise elimination is critical for telecom applications, the telecom dc power supply offers low noise output, so that power supply noise does not interfere with testing of telecom devices.

The E4356A is ideal for manufacturing and R&D engineers who build equipment for the telecom industry that operates from a 48 V or higher dc rail. This telecom equipment includes: base stations, switches, public and private telephone network equipment, PBX systems, and dc/dc power supplies that provide power to this equipment.

Although targeted at the telecom industry where 80V is a common requirement, the E4356A can also be used for other applications requiring 80 Vdc. The E4356A has all of the features found on our general purpose system dc power supplies, such as the 6670 Series of 2000 W system dc power supplies. Therefore it is well suited for both R&D and ATE applications where the features and performance of a one-box solution provide a complete test solution at the price of a single instrument.

### Key Literature

2000/01 Agilent Technologies Power Products Catalog, p/n 5968-2199E

For more information, visit our web site: [www.agilent.com/find/power](http://www.agilent.com/find/power)

### Ordering Information

**Standard:** 191 to 250 Vac, 47 to 63 Hz

**Opt 200** 174 to 220 Vac, 47 to 63 Hz (Japan only)

**Opt 908** Rack-mount Kit (p/n 5062-3977)

**Opt 909** Rack-mount Kit w/Handles (p/n 5062-3983)

### Accessories

p/n 1494-0059 Accessory Slide Kit

p/n 1252-3698 7-pin Analog Plug

p/n 1252-1488 4-pin Digital Plug

p/n 5080-2148 Serial Link Cable 2 m (6.6 ft)

**E3663 AC** Support rails for rack cabinet

### Abbreviated Specifications and Characteristics

Model	E4356A	
<b>Number of Outputs</b>	1	
<b>Output Ratings</b>	Voltage	0 to 70 V/0 to 80 V
	Current	0 to 30 A/0 to 26 A
<b>Programming accuracy</b> At 25° C ±5° C	Voltage	0.04% +80 mV
	Current	0.1% + 25 mA
<b>Ripple and Noise</b> (20 Hz to 20 mHz)	Voltage (rms/p-p)	2 mV/16 mV
	Current (rms)	25 mA
<b>dc Measurement Accuracy</b> (via GPIB or front panel meters with respect to actual output at 25° C ±5° C)	Voltage	0.05% + 120 mV
	Current	0.1% + 35 mA
	High Current Range +20 mA to + rated I	–
	–20 ma to – rated I	–
	Low Current Range –20 mA to + 20 mA	–
<b>Transient Response Time</b>	< 900 us <sup>1</sup>	

<sup>1</sup> Time for the output voltage to recover 20 mV following a change in load current of up to 50% of the output current rating of the supply

**dc Floating Voltage:** Output terminals can be floated up to ±240 Vdc maximum from chassis ground.

**Remote Sensing:** Up to half the rated output voltage can be dropped in each load lead. The drop in the load leads subtracts from the voltage available for the load.

**Command Processing Time:** Average time required for the output voltage to begin to change following receipt of digital data is 20 ms for the power supplies connected directly to the GPIB. (Display disabled.)

**Output Programming Response Time:** The rise time (from 10% to 90% of output current) of the output voltage is less than 100 ms. The fall time (90% to 10%) is 200 ms.

**Modulation:** Analog programming of output voltage and current.

Input signal: 0 to –4 V for voltage, 0 to +6.75 V for current

Input impedance: 30k Ohm or greater

**Input power:** 3,800 VA 2,600 W at full load, 170 W at no load.

**GPIB Interface Capabilities:** SH1, AH1, TE6, LE6, SR1, RL1, PP0, DC1, DT1, E1 and C0. IEE-448.2 and SCPI-compatible command set.

**Regulatory Compliance** Listed to UL 1244; certified to CSA556B, conforms to EN61010.

**Warranty Period:** 3 years.

**Size:** 132.6 mm H x 425.5 mm W x 640 mm D (5.22 in. x 16.75 in. x 25.2 in.)

**Weight:** 27.7 kg (61 lb) net, 31.4 kg (69lb) shipping

E4350B  
E4351B



The E4350B/E4351B simulates the output characteristic of a satellite's solar panels as it moves from darkness to light.

### Solar Array Simulator

The Agilent one-box Solar Array Simulator (SAS) is a dc power source that simulates the output characteristics of a solar array. The SAS is primarily a current source with very low output capacitance and is capable of simulating the I-V curve of different arrays under different conditions (i.e., temperature, age, etc.). The I-V curve is programmable over the IEEE-488.2 bus and is conveniently generated within the SAS.

The SAS provides three current operating modes:

**1. Simulator Mode:** An internal algorithm is used to approximate a SAS I-V curve. Four input parameters: Voc (open circuit voltage), Isc (short circuit current), Imp and Vmp (current and voltage at the peak power point on the curve) are needed to establish a curve in this mode.

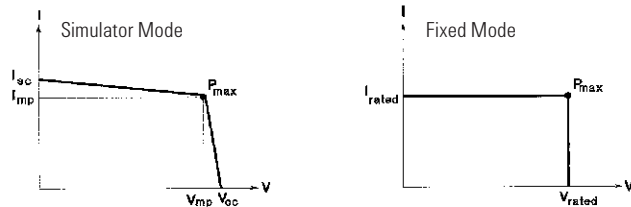

**2. Table Mode:** For a fast and accurate I-V simulation, the SAS provides a table mode. The I-V curve is set by a user-defined table of points. A table can have any length up to 4000 points (a point corresponds to a specific value of I and V). As many as 30 tables may be stored in each SAS built-in volatile and non-volatile memory.

Non-volatile memory can store a maximum of 3500 points. The tables (I-V curves) are easily stored and recalled with an IEEE-488.2 command. The table(s) stored in this memory will be retained when the power is turned off.

Volatile memory greatly increases the flexibility by saving up to 30,000 points. Multiple tables are easily accessed with IEEE-488.2 command. These tables will be erased after power is removed.

In Table Mode, current and voltage offsets can be applied to the selected table to simulate a change in the operating conditions of the solar array.

**3. Fixed Mode:** This is the default mode when the unit is powered on. The unit has the rectangular I-V characteristics of a standard power supply, when an output capacitor is added in this mode.

### Specifications

	E4350B	E4351B
<b>For simulator and table modes</b>		
Max. Power	480 W	480 W
Voc, Max.*	65 V	130 V
Isc, Max.*	8 A	4 A
<b>For fixed mode</b>		
Max. Power	480 W	480 W
V rated*	0–60 V	0–120 V
I rated*	0–8 A	0–4 A

\*Other voltage/current combinations may be configured to meet your unique requirements.

**Programming Accuracy:** at 25° C + 5° C (SAS and Table Mode)

**Voltage:** (Fixed Mode)  
0.075% + 10 mV (E4350B)  
0.075% + 20 mV (E4351B)

**Current:** (Simulator and Fixed Mode)  
0.2% + 20 mA (E4350B)  
0.2% + 10 mA (E4351B)

**Ripple and Noise:** (20 Hz to 20 MHz) with outputs ungrounded or with either terminal grounded (Simulator and Table Mode)

**Voltage:** RMS: 16 mV (E4350B)  
24 mV (E4351B)  
P-P: 125 mV (E4350B)  
195 mV (E4351B)

**Current:** RMS: 4 mA

**Load/Line Regulation:** Change in output voltage or current for any load or line change within ratings (Fixed Mode)

**Voltage:** 2 mV

**Current:** 1 mA

**ac Input:** 104 to 127 Vac

	100 Vac	120 Vac	220 Vac	240 Vac
<b>Voltage</b>	12 A	10 A	5.7 A	5.3 A

### Supplemental Characteristics

Supplemental characteristics are intended to provide information useful in applying the Agilent SAS by describing nonwarranted performance that has been determined by design or type testing.

**Load Switching Recovery Time:** < 5μs when switched from short circuit to variable load to within 1.5 A of an operating point on the I-V curve.

**Remote Sensing:** Up to 2 V+ (Voc–Vmp). Add 3 mV to the voltage load regulation specification for each 1 volt change in the positive output lead due to load current change.

**Analog Programming of Output Current**

**Input Signal:** 0 to –4 V

**Input Impedance:** 20 k Ohms nominal

**Shunt Regulation:** Switching frequency up to 50 kHz

**Series Regulation:** Switching frequency up to 50 kHz

**OVP and OCP:** Overvoltage and overcurrent protection triggers in <100 μs

**Capacitive Load:** In fixed mode, the maximum load capacitance (without causing instability) is 2000μF. In simulator and table mode, it is unconditionally stable at all capacitive loads.

**Inductive Load:** The maximum load inductance (without causing instability) is 200μH

**Regulatory Compliance:** Listed to UL3101, certified to CSA 22.2 NO. 1010.1, complies with EN 61010-1

**RFI Suppression:** Complies with CISPR-II, GROUP1, Class A

**Size:** 132.6 mm H x 425.5 mm W x 497.8 mm D (5.25 in x 16.75 in x 19.6 in)

**Weight:** Net, 25 kg (54 lb); shipping, 28 kg (61 lb)

**Warranty:** Three years

### Key Literature

2000/01 Agilent Technologies Power Products Catalog, p/n 5968-2199E

For more information, visit our web site:

<http://www.agilent.com/find/solarsimulator>

### Ordering Information

Simulators can be ordered as individual modules or as a fully customized system.

**Opt 0BN** Service Manual and extra Operating Guide

**Opt 0BO** Delete Manual

**Opt 100** 87 to 106 Vac, 47 to 63 Hz

**Opt 220** 191 to 233 Vac, 47 to 63 Hz

**Opt 240** 209 to 250 Vac, 47 to 63 Hz

**Opt 908** Rackmount Kit, p/n 5062-3977

**Opt 909** Rackmount Kit with Handles, p/n 5063-9221

### Accessories

p/n 1252-3698 7-pin Analog Plug

p/n 1252-1488 4-pin Digital Plug

p/n 5080-2148 Serial Link Cable 2 m (6.6 ft)

p/n 1494-0059 Accessory Slide Kit



- Ideal for portable product test
- Dynamic pulse measurement
- Precision low current measurement
- Low-output noise
- High-speed programming
- SCPI (Standard Commands for Programmable Instruments)
- GPIB and RS-232 interface
- VXI plug&play drivers



66332A

### Abbreviated Specifications and Characteristics

Model	66332A		
<b>Output ratings</b>	Voltage/Current	0 to 20 V/0 to 5 A	
<b>Programming accuracy</b> at 25° C ± 5° C	Voltage/+Current	0.05%+	10 mV/2 mA
<b>Ripple and noise</b> (20 Hz to 20 MHz, with outputs ungrounded or with other terminal grounded)	Voltage normal mode	(rms/p-p)	0.3 mV/3 mV
	Voltage fast mode	(rms/p-p)	1 mV/10 mV
	Current (rms)		2 mA
<b>DC measurement accuracy</b> via GPIB or front-panel meters with respect to actual output at 25° C ± 5° C	Voltage	0.03% +	3 mV
	Low current range –20 mA to +20 mA	0.1% +	2.5 μA
	High current range +20 mA to + rated I –20 mA to – rated I	0.2% + 0.2% +	0.5 mA 1.1 mA
<b>Load regulation</b>	Voltage/Current	2 mV/1 mA	
<b>Line regulation</b>	Voltage/Current	0.5 mV/0.5 mA	
<b>Transient Response Time:</b> Less than 100 μs (50 μs in the fast mode) for the output voltage to recover to its previous level (within 0.1% of the voltage rating of the supply or 20 mV), following any step change in load current of up to 50% of the output current rating of the supply			
<b>Average programming resolution</b>	Voltage/Current	5 mV/1.25 mA	
<b>OVP accuracy</b>		2.4% +	240 mV
<b>Sink current</b>		5 A	
<b>Sink current tracking</b>	SCPI mode:	0.4% + 2mA	
	Compatibility mode:	–250 mA	

**Dynamic Measurements:** Accuracy of the instantaneous voltage measurement is 0.03% + 5 mV. Accuracy of the instantaneous current measurement is 0.6% + 2 mA. The dc, rms, maximum, minimum, high-level and low-level voltage and current measurements are calculated from the instantaneous voltage and current readings. Up to 4096 data points can be acquired. The sampling interval can be varied from 15.6 μs to 31,200 s. The instantaneous data points can also be read back from the storage buffer. Dynamic measurements on current waveforms with frequency content up to 10 kHz can be made on the low- or high-current range. Above 10 kHz, accurate current measurements can only be made in the high range.

**dc Floating Voltage:** Output terminals can be floated up to ±240 Vdc maximum from chassis ground.

**Remote Sensing:** Up to two volts dropped in each load lead. Add 2 mV to the voltage load regulation specification for each one volt change in the positive output lead due to load current change.

**Command-Processing Time:** Average time required for the output voltage to begin to change following receipt of digital data is 4 ms for the power supplies connected directly to the GPIB. (Display disabled.)

**Output-Programming Response Time:** The rise and fall time (10%/90% and 90%/10%) of the output voltage is less than 2 ms (400 μs for the fast mode). The output voltage change settles within 1 LSB (0.025% x rated voltage) of final value in less than 6 ms (2 ms in the fast mode).

**Measurement Time:** Average time to process query, calculate measurement parameter and return data is 50 ms. (Includes the default time of 30 ms for acquiring data, and a 20 ms data processing overhead)

**Input Power (full load):** 350 VA, 250 W

**Regulatory Compliance:** Listed to UL-3111-1; certified to CSA 22.2. No. 1010-1, complies with EN61010-1, complies with EMC directive 89/336/EEC (ISM Group 1, Class B)

**Warranty Period:** Three years

**Size:** 88.1 mm H x 425.5 mm W x 364.4 mm D (3.5 in x 16.75 in x 14.3 in)

**Weight:** 12.7 kg (28 lb) net, 15.0 kg (33 lb) shipping

### Key Literature

2000/01 Agilent Technologies Power Products Catalog, p/n 5968-2199E

For more information, visit our web site:

<http://www.agilent.com/find/dynamicPS>

### Ordering Information

**Standard:** 104 to 127 Vac, 47 to 63 Hz

**Opt 100** 87 to 106 Vac, 47 to 63 Hz

**Opt 220** 191 to 233 Vac, 47 to 63 Hz

**Opt 230** 207 to 253 Vac, 47 to 63 Hz

**Opt 020** Front-panel Binding Posts

**Opt 760** Isolation and Reversal Relays

**Opt 8ZJ** Delete instrument feet

**Opt 1CM** Rackmount Kit, p/n 5063-9212

**Opt 1CP** Rackmount Kit with Handles, p/n 5063-9219

**Opt 0BN** Service Manual and extra Operating Guide (Standard unit is shipped with operating guide and programming guide only.)

### Accessories

p/n 1494-0060 Rack Slide Kit

6611C  
6612C  
6613C  
6614C

- Precision low current measurement
- Low-output noise
- High-speed programming
- GPIB and RS-232 interface
- SCPI (Standard Commands for Programmable Instruments)
- VXI plug&play drivers



### Abbreviated Specifications and Characteristics

		6611C	6612C	6613C	6614C
<b>Output ratings</b>	Voltage/Current	0 to 8 V/0 to 5 A	0 to 20 V/0 to 2 A	0 to 50 V/0 to 1 A	0 to 100 V/0 to 0.5 A
<b>Programming accuracy</b> at 25° C ±5° C	Voltage/+ Current	0.05% +	5 mV/2 mA	10 mV/1 mA	20 mV/0.75 mA
<b>Ripple and noise</b> (20 Hz to 20 MHz, with outputs ungrounded or with either terminal grounded)	Voltage (rms/p-p) Current (rms)	0.5 mV/3 mV 2 mA	0.5 mV/3 mV 1 mA	0.5 mV/4 mV 1 mA	0.5 mV/5 mV 1 mA
<b>DC measurement accuracy</b> via GPIB or front-panel meters with respect to actual output at 25° C ±5° C	Voltage	0.03% +	2 mV	3 mV	6 mV
	Low current range -20 mA to +20 mA	0.1% +	2.5 µA	2.5 µA	2.5 µA
	High current range +20 mA to + rated I	0.2% +	0.5 mA	0.25 mA	0.2 mA
	-20 mA to -rated I	0.2% +	1.1 mA	0.85 mA	0.8 mA
<b>Load regulation</b>	Voltage/Current	2 mV/1 mA	2 mV/0.5 mA	4 mV/0.5 mA	5 mV/0.5 mA
<b>Line regulation</b>	Voltage/Current	0.5 mV/0.5 mA	0.5 mV/0.5 mA	1 mV/0.25 mA	1 mV/0.25 mA
<b>Transient Response Time:</b> Less than 100 µs for the output voltage to recover to its previous level (within 0.1% of the voltage rating of the supply or 20 mV, whichever is greater) following any step change in load current of up to 50% of the output current rating of the supply					
<b>Average programming resolution</b>	Voltage/Current	2 mV/1.25 mA	5 mV/0.5 mA	12.5 mV/0.25 mA	25 mV/0.125 mA
<b>Sink current</b> (does not track the programmed current)		3 A	1.2 A	0.6 A	0.3 A

4

**dc Floating Voltage:** Output terminals can be floated up to ±240 Vdc maximum from chassis ground

**Remote Sensing:** Up to two volts dropped in each load lead. Add 2 mV to the voltage load regulation specification for each one volt change in the positive output lead due to load current change.

**Command-Processing Time:** Average time required for the output voltage to begin to change following receipt of digital data is 4 ms for the power supplies connected directly to the GPIB.

**Output-Programming Response Time:** The rise and fall time (10/90% and 90/10%) of the output voltage is less than 2 ms. The output voltage change settles within 1 LSB (0.025% x rated voltage) of final value in less than 6 ms.

**Measurement Time:** Average time to make a voltage or current measurement is 50 ms.

**Input Power:** (full load) 160 VA, 100 W (6611C: 2.2A, 120W)

**Regulatory Compliance:** Listed to UL 3111-1; certified to CSA 22.2 No. 1010.1; complies with EN61010-1; complies with EMC directive 89/336/EEC (ISM Group 1, Class B)

**Warranty Period:** Three years

**Size:** 88.1 mm H x 212.8 mm W x 368.3 mm D (3.5 in x 8.4 in x 14.5 in)

**Weight:** 8.2 kg (18.16 lb) net; 10.6 kg (23.5 lb) shipping

### Key Literature

2000/01 Agilent Technologies Power Products Catalog, p/n 5968-2199E

For more information, visit our web site:

<http://www.agilent.com/find/singlePS>

### Ordering Information

**Standard:** 104 to 127 Vac, 47 to 63 Hz

**Opt 100** 87 to 106 Vac, 47 to 63 Hz

**Opt 220** 191 to 233 Vac, 47 to 63 Hz

**Opt 230** 207 to 253 Vac, 47 to 63 Hz

**Opt 760** Isolation and Reversal Relays

**Opt 8ZJ** Delete instrument feet

**Opt ICM** Rackmount Kit, p/n 5063-9240

**Opt 0BN** Service Manual and extra Operating Guide (Standard unit is shipped with operating guide and programming guide only.)

- Multiple sources in an integrated one-box solution
- 2, 3 or 4 independent isolated outputs
- Precision models available, 14-bit programming and readback
- Stable, low ripple and noise power source
- Faster testing with fast up- and down-programming
- Full protection features
- Three-year standard warranty



Agilent's multiple-output power supplies are an ideal solution for automated testing environments that require multiple voltage sources.

- 6621A
- 6622A
- 6623A
- 6624A
- 6625A
- 6626A
- 6627A
- 6628A
- 6629A

### Abbreviated Specifications and Characteristics

		25-watt output	40-watt output	40-watt output	50-watt output	80-watt output	80-watt output
<b>Output Power</b>	Low-range volts, amps	0 to 7 V, 0 to 15 mA	0 to 7 V, 0 to 5 A	0 to 20 V, 0 to 2 A	0 to 16 V, 0 to 200 mA	0 to 7 V, 0 to 10 A	0 to 20 V, 0 to 4 A
	High range volts, amps	0 to 50 V, 0 to 500 mA	0 to 20 V, 0 to 2 A	0 to 50 V, 0 to 0.8 A	0 to 50 V, 0 to 1 A or 0 to 16 V, 0 to 2 A	0 to 20 V, 0 to 4 A	0 to 50 V, 0 to 2 A
<b>Output combinations</b> for each model (total number of outputs)	6621A (2)	—	—	—	—	2	—
	6622A (2)	—	—	—	—	—	2
	6623A (3)	—	1	1	—	1	—
	6624A (4)	—	2	2	—	—	—
	6625A (2) Precision	1	—	—	1	—	—
	6626A (4) Precision	2	—	—	2	—	—
	6627A (4)	—	—	4	—	—	—
<b>Programming accuracy</b> (at 25° C ±5° C)	Voltage	1.5 mV + 0.016% (low) 10 mV + 0.016% (high)	19 mV + 0.06%	50 mV + 0.06%	3 mV + 0.016% (low) 10 mV + 0.016% (high)	19 mV + 0.06%	50 mV + 0.06%
	Current	15 μA + 0.04% (low) 100 μA + 0.04% (high)	50 mA + 0.16%	20 mA + 0.16%	185 μA + 0.04% (low) 500 μA + 0.04% (high)	100 mA + 0.16%	40 mA + 0.16%
<b>Ripple and noise</b> (peak-to-peak, 20 Hz to 20 MHz; rms, 20 Hz to 10 MHz)	Constant voltage rms peak-to-peak	500 μV 3 mV	500 μV 3 mV	500 μV 3 mV	500 μV 3 mV	500 μV 3 mV	500 μV 3 mV
	Constant current rms	0.1 mA	1 mA	1 mA	0.1 mA	1 mA	1 mA
<b>Load regulation</b>	Voltage	0.5 mV	2 mV	2 mV	0.5 mV	2 mV	2 mV
	Current	0.005 mA	1 mA	0.5 mA	0.01 mA	2 mA	1 mA
<b>Load cross regulation</b>	Voltage	0.25 mV	1 mV	2.5 mV	0.25 mV	1 mV	2.5 mV
	Current	0.005 mA	1 mA	0.5 mA	0.01 mA	2 mA	1 mA
<b>Line regulation</b>	Voltage	0.5 mV	0.01% + 1 mV	0.01% + 1 mV	0.5 mV	0.01% + 1 mV	0.01% + 1 mV
	Current	0.005 mA	0.06% + 1 mA	0.06% + 1 mA	0.01 mA	0.06% + 1 mA	0.06% + 1 mA
<b>Transient Response Time:</b> Less than 75 μs for the output to recover to within 75 mV of nominal value following a load change within specifications							
<b>Average programming resolution</b>	Voltage	460 μV (low)/ 3.2 mV (high)	6 mV	15 mV	1 mV (low)/ 3.2 mV (high)	6 mV	15 mV
	Current	1 μA (low)/ 33 μA (high)	25 mA	10 mA	13 μA (low)/ 131 μA (high)	50 mA	20 mA
	OVP	230 mV	100 mV	250 mV	230 mV	100 mV	250 mV
<b>Output setting time</b>		6 ms	6 ms	6 ms	6 ms	6 ms	6 ms

**dc Floating Voltage:** All outputs can be floated up to ±240 Vdc from chassis ground

**Remote Sensing:** Up to 1 V (6621–24A, 6627A); up to 10 V (6625A, 6626A, 6628A, 6629A) drop per load lead.

**Command Processing Time:** 7 ms typical

**Down Programming:** Current sink approximately 110% of the rated output current for operating voltage above 2.5 V

(6621A, 6622A, 6623A, 6624A, 6627A)

**Input Power:** 550 W max., 720 VA max.

**Regulatory Compliance:** Listed to UL-1244; certified to CSA 556B; complies with EN61010-1; carries the CE mark

**RFI Suppression:** Complies with CISPR-11, Group 1, Class B

**Size:** 132.6 mm H x 425.5 mm W x 497.8 mm D (5.22 in x 16.75 in x 19.6 in)

**Weight:**

6621A–24A, 6626A, 6627A, 6629A

Net: 17.4 kg (38 lb); Shipping: 22.7 kg (50 lb)

6625A, 6628A

Net: 15.5 kg (34 lb); Shipping: 20.8 kg (46 lb)

### Key Literature

2000/01 Agilent Technologies Power Products Catalog, p/n 5968-2199E

For more information, visit our web site:

<http://www.agilent.com/find/multiplePS>

### Ordering Information

**6621A** Dual-Output System Power Supply

**6622A** Dual-Output System Power Supply

**6623A** Triple-Output System Power Supply

**6624A** Quad-Output System Power Supply

**6625A** Precision Dual-Output System Power Supply

**6626A** Precision Quad-Output System Power Supply

**6627A** Quad-Output System Power Supply

**6628A** Precision Dual-Output System Power Supply

**6629A** Precision Quad-Output System Power Supply

**Standard:** 104 to 127 Vac, 47 to 66 Hz, 5.4 A

**Opt 100** 87 to 106 Vac, 47 to 66 Hz Input, 6.3 A (Japan only)

**Opt 220** 191 to 233 Vac, 47 to 66 Hz, 3.0 A

**Opt 240** 209 to 250 Vac, 47 to 66 Hz, 3.0 A

**Opt 750** Relay Control and DFI/RI

**Opt 908** Rackmount Kit (p/n 5062-3977)

**Opt 909** Rackmount Kit w/Handles (p/n 5062-3983)

**Opt 910** Service Manual and extra Operating Guide

**Opt 080** Delete Manual

### Accessories

Rack Slide Kit (p/n 1494-0059)

6631B  
6632B  
6633B  
6634B

- Precision low current measurement
- Low-output noise
- High-speed programming
- GPIB and RS-232 interface
- SCPI (Standard Commands for Programmable Instruments)
- VXI plug&play drivers



### Abbreviated Specifications and Characteristics

		6631B	6632B	6633B	6634B
<b>Output ratings</b>	Voltage/Current	0 to 8 V/0 to 10 A	0 to 20 V/0 to 5 A	0 to 50 V/0 to 2 A	0 to 100 V/0 to 1 A
<b>Programming accuracy</b> at 25° C ±5° C	Voltage/+ Current	0.05% +	5 mV/4 mA	10 mV/2 mA	20 mV/1 mA
<b>Ripple and noise</b> (20 Hz to 20 MHz, with outputs ungrounded or with either terminal grounded)	Voltage Normal mode (rms/p-p)	0.3 mV/3 mV	0.3 mV/3 mV	0.5 mV/3 mV	0.5 mV/3 mV
	Voltage Fast mode rms/p-p	1 mV/10 mV	1 mV/10 mV	1 mV/15 mV	2 mV/25 mV
	Current (rms)	3 mA	2 mA	2 mA	2 mA
<b>DC measurement accuracy:</b> via GPIB or front-panel meters with respect to actual output at 25° C ±5° C	Voltage	0.03% +	2 mV	3 mV	6 mV
	Low current range –20 mA to +20 mA	0.1% +	2.5 µA	2.5 µA	2.5 µA
	High current range +20 mA to +rated I	0.2% +	1 mA	0.5 mA	0.25 mA
	–20 mA to –rated I	0.2% +	1.6 mA	1.1 mA	0.85 mA
<b>Load regulation</b>	Voltage/Current	2 mV/2 mA	2 mV/1 mA	4 mV/1 mA	5 mV/1 mA
<b>Line regulation</b>	Voltage/Current	0.5 mV/1 mA	0.5 mV/0.5 mA	1 mV/0.25 mA	1 mV/0.25 mA
<b>Transient Response Time:</b> Less than 100 µs (50 µs in the fast mode) for the output voltage to recover to its previous level (within 0.1% of the voltage rating of the supply) following any step change in load current of up to 50% of the output current rating of the supply					
<b>Average programming resolution</b>	Voltage/Current	2 mV/2.5 mA	5 mV/1.25 mA	12.5 mV/0.5 mA	25 mV/0.25 mA
<b>Sink current</b>		10 A	5 A	2 A	1 A
<b>Sink current tracking</b>	SCPI mode:	0.4% +4mA	0.4% + 2mA	0.4% + 1mA	0.4% + 0.5mA
	Compatibility mode:	–500mA	–250 mA	–100 mA	–50 mA
<b>Minimum current in constant current mode*</b>		40 mA	20 mA	8 mA	4 mA

\* When programming in the 6630A Series language compatibility mode.

**dc Floating Voltage:** Output terminals can be floated up to ±240 Vdc maximum from chassis ground

**Remote Sensing:** Up to two volts dropped in each load lead. Add 2 mV to the voltage load regulation specification for each one volt change in the positive output lead due to load current change.

**Command-Processing Time:** Average time required for the output voltage to begin to change following receipt of digital data is 4 ms for the power supplies connected directly to the GPIB.

**Output-Programming Response Time:** The rise and fall time (10/90% and 90/10%) of the output voltage is less than 2 ms (400 µs in fast mode). The output voltage change settles within 1 LSB (0.025% x rated voltage) of final value in less than 6 ms (2 ms in the fast mode).

**GPIB Interface Capabilities:** IEEE-488.2, SCPI command set, and 6630A Series programming compatibility

**Instrument Time:** Average time to make a voltage or current measurement is 50 ms.

**Input Power** 350 VA, 250 W

**Regulatory Compliance:** Listed to UL-3111-1; certified to CSA 22.2 No. 1010.1; complies with EN 61010-1; complies with EMC directive 89/336/EEC (ISM Group 1, Class B)

**Warranty Period:** Three years

**Size:** 88.1 mm H x 425.5 mm W x 364.4 mm D (3.5 in x 16.8 in x 14.3 in)

**Weight:** 12.7 kg (28 lb) net; 15.0 kg (33 lb) shipping

### Key Literature

2000/01 Agilent Technologies Power Products Catalog, p/n 5968-2199E

For more information, visit our web site:  
<http://www.agilent.com/find/singlePS>

### Ordering Information

**Standard:** 104 to 127 Vac, 47 to 63 Hz

**Opt 100** 87 to 106 Vac, 47 to 63 Hz

**Opt 220** 191 to 233 Vac, 47 to 63 Hz

**Opt 230** 207 to 253 Vac, 47 to 63 Hz

**Opt 020** Front-panel Binding Posts

**Opt 760** Isolation and Reversal Relays (6632B-6634B only)

**Opt 8ZJ** Delete instrument feet

**Opt ICM** Rackmount Kit, p/n 5063-9212

**Opt 1CP** Rackmount Kit with Handles, p/n 5063-9219

**Opt 0BN** Service Manual and extra Operating Guide

(Standard unit is shipped with operating guide and programming guide only.)

### Accessories

p/n 1494-0060 Rack Slide Kit



- Linear output regulation
- Fast up- and down-programming
- SCPI (Standard Commands for Programmable Instruments)
- Complete front-panel control calibration and display
- Remote programming and sensing
- Fan-speed control to minimize acoustic noise
- Low ripple and noise
- Over-voltage and over-current protection



6541A  
6542A  
6543A  
6544A  
6545A  
6641A  
6642A  
6643A  
6644A  
6645A

### Abbreviated Specifications and Characteristics

System Power Supplies (GPIB)		6641A	6642A	6643A	6644A	6645A
Manually Controlled Power Supplies (w/o GPIB)		6541A	6542A	6543A	6544A	6545A
<b>Output ratings</b>	Output voltage	0 to 8V	0 to 20 V	0 to 35 V	0 to 60 V	0 to 120 V
	Output current (40° C)	0 to 20 A	0 to 10 A	0 to 6 A	0 to 3.5 A	0 to 1.5 A
	Maximum current (50° C/55° C)	18 A/17 A	9A/8.5 A	5.4 A/5.1 A	3.2 A/3 A	1.4 A/1.3 A
<b>Programming accuracy</b> (at 25° C ±5° C)	Voltage	0.06% +	5 mV	10 mV	15 mV	26 mV
	Current	0.15% +	26 mA	13 mA	6.7 mA	4.1 mA
<b>Ripple and noise</b> (from 20 Hz to 20 MHz)	Voltage	rms	300 μV	300 μV	400 μV	500 μV
		peak-peak	3 mV	3 mV	4 mV	5 mV
	Current	rms	10 mA	5 mA	3 mA	1.5 mA
<b>Readback accuracy</b> at 25° C ±5° C (percent of reading plus fixed) System models only	Voltage	0.07% +	6 mV	15 mV	25 mV	40 mV
	+Current	0.15% +	18 mA	9.1 mA	5 mA	3 mA
	-Current	0.35% +	40 mA	20 mA	12 mA	6.8 mA
<b>Load regulation</b>	Voltage		1 mV	2 mV	3 mV	4 mV
	Current		1 mA	0.5 mA	0.25 mA	0.25 mA
<b>Line regulation</b>	Voltage		0.5 mV	0.5 mV	1 mV	1 mV
	Current		1 mA	0.5 mA	0.25 mA	0.25 mA
<b>Transient Response Time:</b> Less than 100 μs for the output voltage to recover to its previous level (within 0.1% of the voltage rating of the supply, or 20 mV, whichever is greater) following any step change in load current of up to 50% of rated current						
<b>Average resolution</b>	Voltage		2 mV	5 mV	10 mV	15 mV
	Current		6 mA	3 mA	2 mA	1.0 mA
	OVP		13 mV	30 mV	54 mV	93 mV
<b>OVP accuracy</b>		160 mV	400 mV	700 mV	1.2 V	2.4 V
	System Power Supplies (GPIB)	6641A/	6642A/	6643A/	6644A/	6645A/
	Manually Controlled (w/o GPIB)	6541A/	6542A/	6543A/	6544A/	6545A/

4

**dc Floating Voltage:** Output terminals can be floated up to ±240 Vdc from chassis ground

**Remote Sensing:** Up to half the rated output voltage can be dropped in each load lead. The drop in the load leads subtracts from the voltage available for the load.

**Command Processing Time** (6641A, 6642A, 6643A, 6644A, 6645A only): Average time required for the output voltage to begin to change following receipt of digital data is 20 ms for the power supplies connected directly to the GPIB

**Output Programming Response Time:** The rise and fall time (10/90% and 90/10%) of the output voltage is less than 15 ms. The output voltage change settles within 1 LSB (0.025% x rated voltage) of final value in less than 60 ms.

**Down Programming:** An active down programmer sinks approximately 20% of the rated output current

**Modulation:** (Analog programming of output voltage and current)

**Input Signal:** 0 to -5V

**Input Impedance:** 10 k Ohm nominal

**ac Input:** (ac input frequency 47 to 63 Hz)

<b>Voltage</b>	100 Vac	120 Vac	220 Vac	230 Vac	240 Vac
<b>Current</b>	4.4 A	3.8 A	2.2 A	2.1 A	2.0 A

**Input Power:** 480 VA, 400 W at full load; 60 W at no load

**Regulatory Compliance:** Listed to UL-1244, complies with EN 61010-1; certified to CSA 22.2 No. 231; carries the CE mark

**RFI Suppression:** Complies with CISPR-11, Group 1, Class B

**Size:** 88.1 mm H x 425.5 mm W x 439 mm D (3.5 in x 16.75 in x 17.3 in)

**Weight:** Net, 14.2 kg (31.4 lb); shipping, 16.3 kg (36 lb)

**Warranty Period:** Three years

### Key Literature

2000/01 Agilent Technologies Power Products Catalog, p/n 5968-2199E

For more information, visit our web site:

<http://www.agilent.com/find/singlePS>

### Ordering Information

**Standard:** 104 to 127 Vac, 47 to 63 Hz

**Opt 100** 87 to 106 Vac, 47 to 63 Hz

**Opt 220** 191 to 233 Vac, 47 to 63 Hz

**Opt 240** 209 to 250 Vac, 47 to 63 Hz

**Opt 908** Rackmount Kit (p/n 5063-9212

(support rails required)

**Opt 909** Rackmount Kit w/Handles

(p/n 5063-9219) (support rails required)

**Opt 910** Service Manual, extra Operating Guide and Programming Guide

### Accessories

p/n 1494-0060 Accessory Slide Kit

The following accessories for 6641A, 6642A, 6643A, 6644A and 6645A only:

p/n 1252-3698 7-pin Analog Plug

p/n 1252-1488 4-pin Digital Plug

p/n 5080-2148 Serial Link Cable 2 m (6.6 ft)

E3663AC Support rails for Agilent Rack Cabinets

6651A  
6652A  
6653A  
6654A  
6655A  
6651A  
6652A  
6653A  
6654A  
6655A

- Complete front-panel control, calibration and display
- Remote programming and sensing
- Fan-speed control to minimize acoustic noise
- Low ripple and noise
- Over-voltage and over-current protection
- Linear output regulation
- Fast up- and down-programming
- SCPI (Standard Commands for Programmable Instruments)



### Abbreviated Specifications and Characteristics

System Power Supplies (GPIB)		6651A	6652A	6653A	6654A	6655A
Manually Controlled Power Supplies (w/o GPIB)		6551A	6552A	6553A	6554A	6555A
<b>Output ratings</b>	Output voltage	0 to 8 V	0 to 20 V	0 to 35 V	0 to 60 V	0 to 120 V
	Output current (40° C)	0 to 50 A	0 to 25 A	0 to 15 A	0 to 9 A	0 to 4 A
	Maximum current (50° C/55° C)	45 A/42.5 A	22.5 A/21.3 A	13.5 A/12.8 A	8.1 A/7.7 A	3.6 A/3.4 A
<b>Programming accuracy</b> (at 25° C ±5° C)	Voltage	0.06% +	5 mV	10 mV	15 mV	26 mV
	Current	0.15% +	60 mA	25 mA	13 mA	8 mA
<b>Ripple and noise</b> (from 20 Hz to 20 MHz)	Voltage	rms	300 μV	300 μV	400 μV	500 μV
		peak-peak	3 mV	3 mV	4 mV	5 mV
	Current	rms	25 mA	10 mA	5 mA	3 mA
<b>Readback accuracy</b> at 25° C ±5° C (percent of reading plus fixed) System models only	Voltage	0.07% +	6 mV	15 mV	25 mV	40 mV
	+Current	0.15% +	67 mA	26 mA	15 mA	7 mA
	-Current	0.35% +	100 mA	44 mA	24 mA	15 mA
<b>Load regulation</b>	Voltage	1 mV	2 mV	3 mV	4 mV	5 mV
	Current	2 mA	1 mA	0.5 mA	0.5 mA	0.5 mA
<b>Line regulation</b>	Voltage	0.5 mV	0.5 mV	1 mV	1 mV	2 mV
	Current	2 mA	1 mA	0.75 mA	0.5 mA	0.5 mA
<b>Transient Response Time:</b> Less than 100 μs for the output voltage to recover to its previous level (within 0.1% of the voltage rating of the supply, or 20 mV, whichever is greater) following any step change in load current of up to 50% of rated current						
<b>Average resolution</b>	Voltage	2 mV	5 mV	10 mV	15 mV	30 mV
	Current	15 mA	7 mA	4 mA	2.5 mA	1.25 mA
	OVP	12 mV	30 mV	54 mV	93 mV	190 mV
<b>OVP accuracy</b>		160 mV	400 mV	700 mV	1.2 V	2.4 V
System Power Supplies (GPIB)		6651A/	6652A/	6653A/	6654A/	6655A/
General Purpose (w/o GPIB)		6551A/	6552A/	6553A/	6554A/	6555A/

4

**dc Floating Voltage:** Output terminals can be floated up to ±240 Vdc from chassis ground

**Remote Sensing:** Up to half the rated output voltage can be dropped in each load lead. The drop in the load leads subtracts from the voltage available for the load.

**Command Processing Time** (6651A, 6652A, 6653A, 6654A, 6655A only): Average time required for the output voltage to begin to change following receipt of digital data is 20 ms for the power supplies connected directly to the GPIB

**Output Programming Response Time:** The rise and fall time (10/90% and 90/10%) of the output voltage is less than 15 ms. The output voltage change settles within 1 LSB (0.025% x rated voltage) of final value in less than 60 ms.

**Down Programming:** An active down programmer sinks approximately 20% of the rated output current

**Modulation:** (Analog programming of output voltage and current)

**Input signal:** 0 to -5 V

**Input impedance:** 10 k Ohm nominal

**ac Input:** (ac input frequency 47 to 63 Hz)

<b>Voltage</b>	100 Vac	120 Vac	220 Vac	240 Vac
<b>Current</b>	12 A	10 A	5.7 A	5.3 A

**Input Power:** 1,380 VA, 1,100 W at full load; 120 W at no load

**Regulatory Compliance:** Listed to UL-1244; certified to CSA 556B; complies with EN 61010-1; carries the CE mark

**RFI Suppression:** Complies with CISPR-11, Group 1, Class B

**Size:** 132.6 mm H x 425.5 mm W x 497.8 mm D (5.22 in x 16.75 in x 19.6 in)

**Weight:** Net, 25 kg (54 lb); shipping, 28 kg (61 lb)

**Warranty Period:** Three years

### Key Literature

2000/01 Agilent Technologies Power Products Catalog, p/n 5968-2199E

For more information, visit our web site:  
<http://www.agilent.com/find/singlePS>

### Ordering Information

**Standard:** 104 to 127 Vac, 47 to 63 Hz

**Opt 100** 87 to 106 Vac, 47 to 63 Hz

**Opt 220** 191 to 233 Vac, 47 to 63 Hz

**Opt 240** 209 to 250 Vac, 47 to 63 Hz

**Opt 908** Rackmount Kit (p/n 5062-3977)  
(support rails required)

**Opt 909** Rackmount Kit w/ Handles  
(p/n 5063-9221) (support rails required)

**Opt 910** Service Manual, extra Operating Guide  
and Programming Guide

### Accessories

Rack Slide Kit (p/n 1494-0059)

The following accessories for 6651A, 6652A, 6653A, 6654A and 6655A only:

p/n 1252-3698 7-pin Analog Plug

p/n 1252-1488 4-pin Digital Plug

p/n 5080-2148 Serial Link Cable 2 m (6.6 ft)

E663AC Support Rails for Agilent rack cabinets

- Low ripple and noise
- Fast up- and down-programming
- SCPI (Standard Commands for Programmable Instruments)
- Complete front-panel control, calibration and display
- Remote programming and sensing
- Fan-speed control to minimize acoustic noise
- Low ripple and noise
- Over-voltage and over-current protection



6571A  
6572A  
6573A  
6574A  
6575A  
6671A  
6672A  
6673A  
6674A  
6675A

### Abbreviated Specifications and Characteristics

System Power Supplies (GPIB)			6671A	6672A	6673A	6674A	6675A
General Purpose Power Supplies (w/o GPIB)			6571A	6572A	6573A	6574A	6575A
<b>Output ratings</b>	Output voltage		0 to 8 V	0 to 20 V	0 to 35 V	0 to 60 V	0 to 120 V
	Output current (40° C)		0 to 220 A	0 to 100 A	0 to 60 A	0 to 35 A	0 to 18 A
<b>Programming accuracy</b> (at 25° C ±5° C)	Voltage	0.04% +	8 mV	20 mV	35 mV	60 mV	120 mV
	Current	0.11% +	125 mA	60 mA	40 mA	25 mA	12 mA
<b>Ripple and noise</b> (from 20 Hz to 20 MHz)	Voltage	rms	650 $\mu$ V	750 $\mu$ V	800 $\mu$ V	1.25 mV	1.9 mV
		peak-peak	7 mV	9 mV	9 mV	11 mV	16 mV
	Current	rms	200 mA	100 mA	40 mA	25 mA	12 mA
<b>Readback accuracy</b> at 25° C ±5° C (percent of reading plus fixed) System models only	Voltage	0.05% +	12 mV	30 mV	50 mV	90 mV	180 mV
	±Current	0.1% +	150 mA	100 mA	60 mA	35 mA	18 mA
<b>Load and line regulation</b>	Voltage	0.002%+	300 $\mu$ V	650 $\mu$ V	1.2 mV	2 mV	4 mV
	Current	0.005%+	10 mA	7 mA	4 mA	2 mA	1 mA
<b>Transient Response Time:</b> Less than 900 $\mu$ s for the output voltage to recover 100 mV following a change in load from 100% to 50%, or 50% to 100% of the output current rating of the supply							
<b>Typical resolution</b>	Voltage		2 mV	5 mV	10 mV	15 mV	30 mV
	Current		55 mA	25 mA	15 mA	8.75 mA	4.5 mA
	OVP		15 mV	35 mV	65 mV	100 mV	215 mV
<b>Output voltage programming response time*</b> (excluding command processing time) System models only			30 ms	60 ms	130 ms	130 ms	195 ms
System Power Supplies (GPIB)			6671A/	6672A/	6673A/	6674A/	6675A/
General Purpose (w/o GPIB)			6571A/	6572A/	6573A/	6574A/	6575A/

\* Full load programming rise/fall time (10% to 90% or 90% to 10%) with full resistive load equal to rated output voltage/rated output current.

**dc Floating Voltage:** Output terminals can be floated up to  $\pm 240$  Vdc from chassis ground

**Output Common-Mode Noise Current:** (to signal ground binding post) 500  $\mu$ A rms, 4 mA peak-to-peak

**Remote Sensing:** Up to half the rated output voltage can be dropped in each load lead. The drop in the load leads subtracts from the voltage available for the load.

**Command Processing Time:** (6671A, 6672A, 6673A, 6674A, 6675A only) Average time required for the output voltage to begin to change following receipt of digital data is 20 ms for the power supplies connected directly to the GPIB

**Modulation:** (Analog programming of output voltage and current)

**Input Signal:** 0 to -4V for voltage, 0 to 7 V for current

**Input Impedance:** 60 K Ohm, nominal

**Input Power:** 3,800 VA, 2,600 W at full load; 170 W at no load

**Regulatory Compliance:** Listed to UL-1244; certified to CSA 556B; complies with EN 61010-1; carries the CE mark

**RFI Suppression:** Complies with CISPR-11, Group 1, Class A

**Size:** 132.6 mm H x 425.5 mm W x 640 mm D (5.22 in x 16.75 in x 25.2 in)

**Weight:** Net, 27.7 kg (61 lb); shipping, 31.4 kg (69 lb)

**Warranty Period:** Three years

### Key Literature

2000/01 Agilent Technologies Power Products Catalog, p/n 5998-2199E

For more information, visit our web site:

<http://www.agilent.com/find/singlePS>

### Ordering Information

**Standard:** 191 to 250 Vac, 47 to 63 Hz

**Opt 200** 174 to 220 Vac, 47 to 63 Hz (Japan only)

**Opt 908** Rackmount Kit (p/n 5062-3977)  
(support rails required)

**Opt 909** Rackmount Kit w/ Handles  
(p/n 5063-9221) (support rails required)

**Opt 910** Service Manual, extra Operating Guide  
and Programming Guide

A line cord option must be specified. See page 191 for ordering information.

### Accessories

Rack Slide Kit (p/n 1494-0059)

The following accessories for 6671A, 6672A, 6673A, 6674A and 6675A only:

p/n 1252-3698 7-pin Analog Plug

p/n 1252-1488 4-pin Digital Plug

p/n 5080-2148 Serial Link Cable 2 m (6.6 ft)

E3663AC Support rails for Agilent rack cabinets

6680A  
6681A  
6682A  
6683A  
6684A

- “One-Box” solution: includes V and I read-back
- Low ripple and noise
- Fast up- and down-programming
- High-accuracy current programming and read back
- SCPI (Standard Commands for Programmable Instruments)
- Selectable compensation for inductive loads



### Abbreviated Specifications and Characteristics

System Power Supplies (GPIB)		6680A	6681A	6682A	6683A	6684A	
<b>Output ratings</b>	Voltage	0 to 5 V	0 to 8 V	0 to 21 V	0 to 32 V	0 to 40 V	
	Current (derated linearly 1%/°C from 40° to 55° C)	0 to 875 A	0 to 580 A	0 to 240 A	0 to 160 A	0 to 128 A	
<b>Programming accuracy</b> (at 25° C ±5° C)	Voltage	0.04% +	5 mV	8 mV	21 mV	40 mV	
	Current	0.1% +	450 mA	300 mA	125 mA	85 mA	65 mA
<b>Ripple and noise</b> (from 20 Hz to 20 MHz)	Constant voltage rms	1.5 mV	1.5 mV	1.0 mV	1.0 mV	1.0 mV	
	peak-to-peak	10 mV	10 mV	10 mV	10 mV	10 mV	
	Constant current rms	290 mA	190 mA	40 mA	28 mA	23 mA	
<b>Readback accuracy</b> at 25° C ±5° C (percent of reading plus fixed)	Voltage	0.05% +	7.5 mV	12 mV	32 mV	48 mV	60 mV
	Current	0.1% +	600 mA	400 mA	165 mA	110 mA	90 mA
<b>Load and line regulation</b>	Voltage	0.002% +	190 μV	300 μV	650 μV	1.1 mV	1.5 mV
	Current	0.005% +	65 mA	40 mA	17 mA	12 mA	9 mA
<b>Transient Response Time:</b> Less than 900 μs for the output voltage to recover within 150 mV following a change in load from 100% to 50%, or 50% to 100% of the output current rating of the supply							
<b>Average programming resolution</b>	Voltage	1.35 mV	2.15 mV	5.7 mV	8.6 mV	10.8 mV	
	Current	235 mA	155 mA	64 mA	43 mA	34 mA	
	OVP	30 mV	45 mV	120 mV	180 mV	225 mV	
<b>Output voltage programming response time</b> (excludes command-processing time)	Full-load programming rise or fall time (10/90% or 90/10%, resistive load)	9 ms	12 ms	45 ms	60 ms	60 ms	
<b>Output common-mode noise current</b> (to signal-ground binding post)	rms	1.5 mA	1.5 mA	3 mA	3 mA	3 mA	
	peak-to-peak	10 mA	10 mA	20 mA	20 mA	20 mA	

**dc Floating Voltage:** Output terminals can be floated up to ±60 Vdc maximum from chassis ground

**Remote Sensing:** Up to half the rated output voltage can be dropped in each load lead. The drop in the load leads subtracts from the voltage available for the load.

**Command Processing Time:** Average time required for the output voltage to begin to change following receipt of digital data is 20 ms for power supplies connected directly to the GPIB

**Modulation** (analog programming of output voltage and current)

**Input Signal:** 0 to -5 V for voltage, 0 to +5 V for current

**Input Impedance:** 30 k Ohm or greater

**ac Input** (47 to 63 Hz): 180 to 235 Vac (line-to-line, 3 phase), 27.7 A rms maximum; 360 to 440 Vac, 14.3 A rms maximum (maximum line current includes 5% unbalanced phase voltage condition.) Output voltage derated at 50 Hz and below 200 Vac.

**Input Power:** 7350 VA and 6000 W maximum; 160 W at no load

**Regulatory Compliance:** Listed to UL-1244; certified to CSA 22.2 No. 231; complies with EN 61010-1; carries the CE mark

**RFI Suppression:** Complies with CISPR-11, Group 1, Class A

**Size:** 220 mm H x 425.5 mm W x 675.6 mm D (8.75 in x 16.75 in x 26.6 in)

**Weight:** Net, 51.3 kg (113 lb); shipping, 63.6 kg (140 lb)

**Warranty Period:** Three years

### Key Literature

2000/01 Agilent Technologies Power Products Catalog, p/n 5968-2199E

For more information, visit our web site:

<http://www.agilent.com/find/singlePS>

### Ordering Information

**Opt 400** 360 to 440 Vac, 3 phase, 47 to 63 Hz

**Opt 601** Output Connector Kit (required for bench applications) includes bus-bar spacer, connector bolts, and output cover (p/n 5060-3515)

**Opt 602** Two Bus-Bar Spacers for paralleling power supplies (p/n 5060-3514)

**Opt 908** Rackmount Kit (p/n 5062-3977 and p/n 5063-9212)

**Opt 909** Rackmount Kit with Handles (p/n 5063-9221 and p/n 5063-9219). Support rails required for Option 908 and 909 Rack: E3663A, Rack Slides p/n 1494-0058, third party rack: E3664A

**Opt 910** Service Manual (p/n 5960-5590), extra Operating Guide and Programming Guide

### Accessories

p/n 5060-3513 Three 30-A Replacement Fuses for 180 to 235 Vac line

p/n 5060-3512 Three 16-A Replacement Fuses for 360 to 440 Vac line





Above: 6023A, 6028A  
Below: 6010A, 6011A, 6012A and 6015A

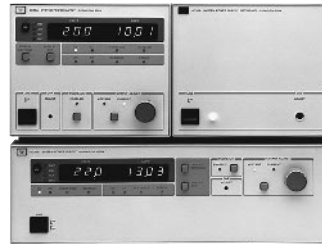

Above: 6033A and 6031A (Option 001 on right)  
Below: 6030A, 6031A, 6032A, and 6035A

6010A  
6011A  
6012A  
6015A  
6023A  
6028A  
6030A  
6031A  
6032A  
6033A  
6035A  
6038A

### Abbreviated Specifications and Characteristics

System Autorangers (GPIB)		6030A	6031A	6032A	6033A	6035A	6038A	
Autorangers (w/o GPIB)		6010A	6011A	6012B	6023A	6015A	6028A	
<b>Output ratings</b>	Voltage	0 to 200 V	0 to 20 V	0 to 60 V	0 to 20 V	0 to 500 V	0 to 60 V	
	Current	0 to 17 A	0 to 120 A	0 to 50 A	0 to 30 A	0 to 5 A	0 to 10 A	
<b>Maximum power</b>	Watts	1,200 W	1,072 W	1,200 W	240 W	1,050 W	240 W	
<b>Autoranging output</b>	V1, P1	200 V, 5 A	20 V, 50 A	60 V, 17.5 A	20 V, 10 A	500 V, 2 A	60 V, 3.3 A	
	V2, P2	120 V, 10 A	14 V, 76 A	40 V, 30 A	14 V, 17.2 A	350 V, 3 A	40 V, 6 A	
	V3, P3	60 V, 17 A	7 V, 120 A	20 V, 50 A	6.7 V, 30 A	200 V, 5 A	20 V, 10 A	
<b>Programming accuracy</b> (at 25° C ±5° C) System models only	Voltage	0.035% +145 mV	0.035% +15 mV	0.035% +40 mV	0.035% +9 mV	0.25% +400 mV	0.035% +40 mV	
	Current	0.2% +25 mA	0.25% +250 mA	0.2% +85 mA	0.15% +20 mA	0.3% +63 mA	0.09% +10 mA	
<b>Ripple and noise</b> , (20 Hz to 20 MHz)	Voltage	rms	22 mV	8 mV	5 mV	3 mV	50 mV	3 mV
		p-p	50 mV	50 mV	40 mV	30 mV	160 mV	30 mV
	Current	rms	15 mA	120 mA	25 mA	30 mA	50 mA	5 mA
<b>Readback accuracy</b> (at 25° C ±5° C) System models only	Voltage	0.08% +80 mV	0.08% +7 mV	0.08% +20 mV	0.07% +6 mV	0.5% +200 mV	0.07% +50 mV	
	Current	0.36% +15 mA	0.4% +100 mA	0.36% +35 mA	0.3% +25 mA	0.5% +50 mA	0.2% +11 mA	
<b>Load regulation</b>	Voltage	0.01%+	5 mV	3 mV	5 mV	40 mV	3 mV	
	Current	0.01%+	10 mA	15 mA	10 mA	.03+34 mA	5 mA	
<b>Line regulation</b> System models only	Voltage	0.01%+	5 mV	2 mV	3 mV	13 mV	2 mV	
	Current	0.01%+	5 mA	25 mA	10 mA	6 mA	.03+17 mA	
<b>Transient response time</b> 10% step change	Time	2 ms	2 ms	2 ms	1 ms	5 ms	1 ms	
	Level	150 mV	100 mV	100 mV	50 mV	200 mV	75 mV	
<b>dc floating voltage</b> (either terminal can be grounded or floated from chassis ground)		±550 V	±240 V	±240 V	±240 V	±550 V	±240 V	
<b>ac input current</b>	100 Vac (system only)	24 A	24 A	24 A	6.0 A	24 A	6.0 A	
	120 Vac	24 A	24 A	24 A	6.5 A	24 A	6.5 A	
	220 Vac	15 A	15 A	15 A	3.8 A	15 A	3.8 A	
	240 Vac	14 A	14 A	14 A	3.6 A	14 A	3.6 A	
<b>Weight</b>	Net	16.3 kg (36 lb)	16.3 kg (36 lb)	16.3 kg (36 lb)	9.6 kg (21 lb)	16.3 kg (36 lb)	9.6 kg (21 lb)	
	Shipping	21.7 kg (48 lb)	21.7 kg (48 lb)	21.8 kg (48 lb)	11.4 kg (25 lb)	21.7 kg (48 lb)	11.4 kg (25 lb)	
System Autorangers (GPIB)		6030A/ 6010A/	6031A/ 6011A/	6032A/ 6012B/	6033A/ 6023A/	6035A/ 6015A/	6038A/ 6028A/	

**Remote Sensing:** Up to 2 V drop in each lead. Voltage regulation degrades for greater than 0.5 V drop.

**Regulatory Compliance:** Listed to UL-1244; certified to CSA 556B; complies with EN 61010-1, carries the CE mark

**RFI Suppression:** Complies with CISPR-11, Group 1, Class A

**Inductive Load:** 6023A, 6028A are stable in CC mode for loads up to 1 H. 6010A–6012B, 6015A are stable in CC mode for loads up to 100 mH.

**Size:**

6030A–32A, 6035A: 132.6 mm H x 425.5 mm W x 503.7 mm D (5.25 in x 16.75 in x 19.83 in).

6033A, 6038A, 6023A, 6028A: 177.0 mm H x 212.3 mm W x 516.4 mm D (6.97 in x 8.36 in x 17.87 in).

6010A–12B, 6015A: 132.6 mm H x 425.5 mm W x 516.4 mm D (5.25 in x 16.75 in x 20.33 in).

### Key Literature

2000/01 Agilent Technologies Power Products Catalog, p/n 5968-2199E

For more information, visit our web site:

<http://www.agilent.com/find/autorangingPS>

### Ordering Information

**Standard:** 104 to 127 VAC, 48 to 63 Hz

**Opt 001** Front panel has only line switch, line indicator, and OVP adjust (6030A–33A and 6038A only)

**Opt 002** Provides extra programming and monitoring capabilities (6010A–12B, 6023A, 6028A only)

**Opt 100** 87 to 106 Vac, 48 to 63 Hz (power supply output is derated to 75%) 6030A–33A, 6035A, 6038A only

**Opt 220** 191 to 233 Vac, 48 to 63 Hz

**Opt 240** 209 to 250 Vac, 48 to 63 Hz

**Opt 800** Rackmount Kit for Two Half-rack Units Side by Side. p/n 5061-9694 and 5062-3978

**Opt 908** Rackmount Kit for a Single Half-rack Unit Models 6023A, 6028A, 6033A and 6038A

(with blank filler panel); p/n 5062-3960 Models 6010A–12B, 6015A, 6030A–32A

and 6035A; p/n 5062-3977

**Opt 909** Rackmount Kit with Handles. For 6010A–12B, 6015A, 6030A–32A, 6035A; p/n 5062-3983

**Opt 910** Service Manual and extra Operating Guide

For Models 6010A–12B, 6015A, 6023A, 6028A

For Models 6030A–33A, 6035A, 6038A

A line cord option must be specified for 6010A–12B, 6015A, 6030A–32A, 6035A. See page 191 for ordering information.

**Accessories**

5080-2148 Serial Link Cable, 2 m (6.6 ft) for 6030A, 6031A, 6031A, 6032A, 6033A, 6035A, and 6038A

1494-0060 Rack Slide Kit

59510A  
59511A

- Relay accessories to isolate load from dc output
- Switch and sequence power and sense leads
- DC output polarity reversal (59511A only)



59511A

### 59510A and 59511A Relay Devices

The Agilent 59510A and 59511A are designed for control from 66XXA and 603XA series power supplies. These can be configured to switch dc power in multiple test fixtures or provide extra protection when a fault condition requires an emergency shutdown. Each unit switches one power supply output and can be used with any dc power supply within the voltage and current limits. The 59511A has all of the features of the 59510A, plus relays for reversing polarity. Using the PEM fasteners provided, both models can be mounted to a flat surface on any of the three sides (not for use on 6035A).

### Specifications

**Operating Ranges:** 200 V at 20 A, 120 V at 30 A, or 48 V at 60 A  
**dc Floating Voltage:** Input to output, 200 Vdc; input or output to ground, 500 Vdc; TTL control to ground, 240 Vdc  
**Settling Time** (TTL control): Connect, 440 ms; disconnect, 160 ms; polarity reversal, 600 ms  
**dc Voltage Drop** (at 60 A): 0.5 V maximum on each relay  
**ac Input:** Can be set for 100, 120, 220, or 240 Vac (–13%, +6%) at 48 to 63 Hz

#### Weight:

**59510A:** Net, 2.3 kg (5 lb); shipping, 3.6 kg (8 lb); shipping with Option 850, 4.1 kg (9 lb)  
**59511A:** Net, 3.6 kg (8 lb); shipping, 5.0 kg (11 lb); shipping with Option 850, 5.5 kg (12 lb)

**Mounting Orientation:** Within  $\pm 10^\circ$  from vertical

**Size:** 130.6 mm H x 185.4 mm W x 198.6 mm D (5.14 in x 7.26 in x 7.81 in)

### Key Literature

2000/01 Agilent Technologies Power Products Catalog, p/n 5968-2199E

For more information, visit our web site:  
<http://www.agilent.com/find/power>

### Terminated Line Cords

Line cords with plugs

#### Option 841

12 AWG; UL-listed, CSA-certified; with NEMA 6-20P, 20-A, 250-V plug. Suggested for use in North and South America and Japan. Note for 6670 and 6570 Series: not intended for use in Canada. Intended for use on a dedicated branch circuit.



#### Option 842

4-mm<sup>2</sup> wire size; harmonized cordage with IEC 309, 32-A, 220-V plug. Suggested for use in Europe and other areas not listed.



#### Option 844

10 AWG; UL-listed, CSA-certified; with NEMA L6-30P, 30-A, 250-V locking plug. Suggested for use in North and South America.



#### Option 845

1.5-mm<sup>2</sup> wire size; harmonized cordage with IEC 309, 16-A, 220-V plug. Suggested for use in Denmark, Switzerland, Austria, China, and other countries not listed.



#### Option 846

10 AWG; UL-listed, CSA-certified; with NEMA L5-30P, 30-A, 120-V locking plug. Suggested for use in North America.



#### Option 847

1.5-mm<sup>2</sup> wire size; harmonized cordage with CEE 7/7, 16-A, 220-V plug. Suggested for use in continental Europe.



#### Option 848

1.5-mm<sup>2</sup> wire size; harmonized cordage with BS 546, 15-A, 240-V plug. Suggested for use in India and South Africa.



### Ordering Information

- 59510A** Output Isolation Relay Accessory
- 59511A** Output Isolation, Polarity Reversal Accessory
- Opt 850** Rackmount Kit (side-by-side mounting of two units requires two kits)
- Opt 910** Extra Operating and Service Manual, p/n 5957-6382

### Power-Supply AC Line Cord Options

Power distribution regulations and techniques vary greatly among geographic regions. For this reason, line cord type must be specified for high-power (1000- to 5000-W) dc power supplies at the time of ordering. The 66000A modular power system mainframe is included because one line cord might supply ac power for up to eight 150-W modules. If no line cord option is specified for these models, an unterminated cable will be shipped with the unit.

### Option Descriptions

Order the correct option according to local electrical codes. All the cords listed are 2.5 m (about 8.2 ft) long.

#### Unterminated Line Cords (user supplies plug)

**Option 831:** 12 AWG; UL-listed, CSA-certified; unterminated. Suggested for use in North and South America. Note for 6670 and 6570 Series: intended for use on a dedicated branch circuit and not intended for use in Canada. Note for 6030 and 66000 Series: intended for connection to 200- to 240-Vac service.

**Option 832:** 4-mm<sup>2</sup> wire size; harmonized cordage; unterminated. Suggested for use in Europe and other areas not listed.

**Option 833:** 1.5-mm<sup>2</sup> wire size; harmonized cordage; unterminated. For use in Europe and other areas not listed. Note for 6030 and 66000 Series: intended for connection to 200- to 240-Vac service.

**Option 834:** 10 AWG; UL-listed, CSA-certified; unterminated. Suggested for use in North and South America. Note for 6030 and 66000 Series: intended for connection to 100- to 120-Vac service.

#### Options Available

Options	6010A Series 6030A Series (1000 W only)	6570A 6670A Series	66000A Mainframe	6812A 6841A	6813A 6842A
831	•	•	•	•	•
832		•			•
833	•	•	•	•	•
834		•		•	•
841	•	•	•	•	•
842		•			•
844		•			•
845	•		•	•	
846	•		•	•	
847	•		•	•	
848	•		•	•	

\*available

- 30 – 100W single and dual output
- Dual output ranges
- Front and rear terminal outputs
- Over-voltage protection (for all output)
- Remote sense
- Standard GPIB and RS-232 with SCPI



E3640A – E3649A

### E3640A – 49A Single and Dual Output



Agilent's new E364xA-series programmable DC power supplies are 30W/50W/80W single output and 60W/100W dual output power supplies with standard GPIB & RS-232 interface. For general-purpose use, these programmable power supplies offer the performance of system power supplies at a surprisingly affordable price.

### Clean and Stable Output

All models deliver clean and reliable power, dependable regulation (0.01%) and fast transient response (<50usec to within 15mV). With 0.01% load and line regulation, E364xA power supplies keep output steady when power line and load changes occur. These linear supplies specify both normal mode voltage noise and common mode current noise to assure less interference with your DUT.

### Standard remote interface

Standard GPIB and RS-232 interfaces, SCPI programming and *plug&play* drivers for Agilent VEE and NI LabView make it easy to program and integrate into automated test system. You can monitor the output terminals for voltage and current and a query command lets you read the programmed voltage and current.

### Versatile Power

E364xA power supplies give you the flexibility to select from dual output ranges. Both front and rear output terminals are standard and output load is protected against over-voltage protection function. Remote sense is available to eliminate the errors due to voltage drops on the load leads. New front panel binding posts offer flexibility to use safety test leads, banana plugs or stripped wires. Store and recall key enables you to save and recall up to 5 frequently used operating states. For dual output models, two outputs are electrically isolated to each other.

E3640A  
E3641A  
E3642A  
E3643A  
E3644A  
E3645A  
E3646A  
E3647A  
E3648A  
E3649A  
E3619A

4

### Abbreviated Specifications and Characteristics (at 0° C to 55° C unless otherwise specified)

Model Number	E3640A	E3641A	E3642A	E3643A	E3644A	E3645A
Maximum Power	30W	30W	50W	50W	80W	80W
# of Output	1	1	1	1	1	1
Output Ratings	0 to 8V/3A or 0 to 20V/1.5A	0 to 35V/0.8A or 0 to 60V/0.5A	0 to 8V/5A or 0 to 20V/2.5A	0 to 35V/1.4A or 0 to 60V/0.8A	0 to 8V/8A or 0 to 20V/4A	0 to 35V/2.2A or 0 to 60V/1.3A

Model Number	E3646A	E3647A	E3648A	E3649A
Maximum Power	60W	60W	100W	100W
# of Output	2	2	2	2
Output Ratings	Two 0 to 8V/3A or 0 to 20V/1.5A	Two 0 to 35V/0.8A or 0 to 60V/0.5A	Two 0 to 8V/5A or 0 to 20V/2.5A	Two 0 to 35V/1.4A or 0 to 60V/0.8A

Common to All Models	
<b>Load and Line Regulation</b> ±(% of output + offset)	Voltage Current <0.01% + 3mV <0.01% + 250µA
<b>Ripple and Noise</b> (20Hz to 20MHz)	Normal Mode Voltage Normal Mode Current Common Mode Current <5mVpp/0.5mVrms for 8V/20V models, <8mVpp/1mVrms for 35V/60V models <4mArms <1.5µArms
<b>Accuracy</b> 12 Months (@ 25° C ± 5° C), ±(% output + offset)	Programming Voltage Current Readback Voltage Current <0.05% + 10mV (<0.1% + 25mV for output 2 of E3646/47/48/49A) <0.2% + 10mA <0.05% + 5mV (<0.1% + 25mV for output 2 of E3646/47/48/49A) <0.15% + 5mA (<0.15% + 10mA for output 2 of E3646/47/48/49A)
<b>Resolution</b>	Program Readback Meter <5mV/1mA <2mV/1mA 10mV/1mA
<b>Transient Response</b>	Less than 50usec for output to recover to within 15mV following a change in output current from full load to half load or vice versa.

### Product Regulation

Designed to comply with UL3111-1; certified to CSA 22.2 No. 1010.1; conforms to IEC 1010-1; complies with EMC directive 89/336/EEC (Group1, Class A)

### Size:

104 mm H x 254 mm W x 374 mm D (4.1 in x 10 in x 14.8 in),  
(For E3640A – E3645A)  
133 mm H x 228 mm W x 374 mm D (5.2 in x 8.9 in x 14.7 in),  
(For E3646A – E3649A)

**Warranty:** 3 years

- E3640A
- E3641A
- E3642A
- E3643A
- E3644A
- E3645A
- E3646A
- E3647A
- E3648A
- E3649A
- E3619A



E3619A Power Supply Test Leads

### E3619A Power Supply Test Leads

New power supply test leads have been designed to work with E36xxA series power supplies that are capable of handling up to 8A of current continuously. These test leads feature a minigrabber on one end and a banana plug, with a retractable sleeve, on the other. Each set consists of one red and one black 1.2m (4 ft) silicon insulated, 18 AWG, 1.2m (4 ft) lead.

4

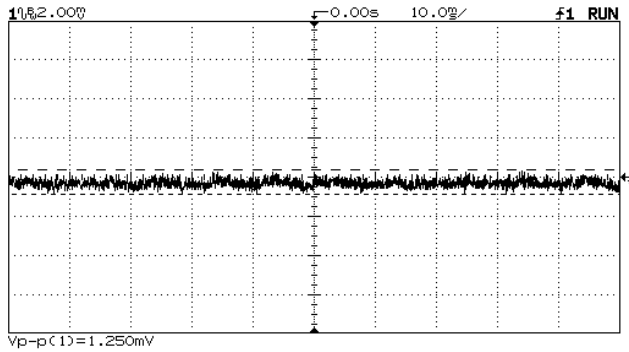

Clean output power assures stable operation that won't burden your circuits under test with unwanted signals.

### Key Literature

2000/01 Agilent Technologies Power Products Catalog, p/n 5968-2199E  
 Agilent GP Instruments Catalog, p/n 5968-8736E

For more information, visit our web site:  
<http://www.agilent.com/find/power>

### Ordering Information

- E3640A** 30W Single Output Power Supply
  - E3641A** 30W Single Output Power Supply
  - E3642A** 50W Single Output Power Supply
  - E3643A** 50W Single Output Power Supply
  - E3644A** 80W Single Output Power Supply
  - E3645A** 80W Single Output Power Supply
  - E3646A** 60W Dual Output Power Supply
  - E3647A** 60W Dual Output Power Supply
  - E3648A** 100W Dual Output Power Supply
  - E3649A** 100W Dual Output Power Supply
- (Standard unit is shipped with operating and service manual, quick reference guide and ac power cord.)
- Standard** 115Vac ± 10% at 47Hz to 63Hz
  - Opt 0E9** 100Vac ± 10% at 47Hz to 63Hz
  - Opt 0E3** 230Vac ± 10% at 47Hz to 63Hz
  - Opt 1CM** Rackmount Kit
  - For E3640A – E3645A, Agilent p/n 5063-9240
  - For E3646A – E3649A, Agilent p/n 5063-9243
  - Opt 910** Extra manual set

### Accessory

**E3619A** 18AWG Power Supply Test Leads

 = Indicates QuickShip availability.





### E3631A Triple-output Features

- 80 watts of power
- Triple outputs
- GPIB/RS-232 standard
- Dual voltage and current meters
- SCPI (Standard Commands for Programmable Instruments)

### E3632A Single-output Features

- 105/120 watts of power
- Single output, dual range
- Low noise/excellent regulation
- GPIB/RS-232 standard
- Remote sense, OVP and OCP capability
- 16-bit programming resolution and high accuracy

### E3633A, E3634A Single-output Features

- 160/200 watts of power
- Single output, dual range
- Front and rear panel terminals
- Low noise/excellent regulation
- GPIB/RS-232 standard
- Remote sense, OVP and OCP capability
- 16-bit programming resolution and high accuracy



Above: E3632A, Below: E3631A

E3633A/34A

E3631A  
E3632A  
E3633A  
E3634A

## E3631A–E3634A



The E3631A is a triple-output programmable dc power supply designed to meet the most exacting engineering requirements with traditional quality and reliability designed in.

The E3632A (120 W) and E3633A, E3634A (200 W) are single output, dual range programmable dc power supplies designed to deliver reliable and high quality operation at a very attractive price.

### Low Noise/Excellent Regulation

0.01% load and line regulation keep the output steady. The linear supply specifies both normal-mode voltage noise and common-mode current noise. The low normal-mode specification assures clean power for precision circuitry and the low common-mode current provides isolation from power line current injection.

### Front Panel Operation

Both voltage and current can be monitored simultaneously for output from the front panel on an easy-to-read vacuum fluorescent display. A knob allows you to set the output at the resolution you need for the most exacting adjustments, quickly and easily. Store and recall key enables you to save and recall up to three frequently-used states. The output on/off button enables/disables the output.

### Isolated

All the outputs are isolated from the chassis ground and from the remote interface. In the E3631A, 6 V supply is isolated from the  $\pm 25$  V supply to minimize any interference between circuits-under-test.

For more information, visit our web site:

<http://www.agilent.com/find/power>

### Abbreviated Specifications and Characteristics at 0° C to 55° C unless otherwise specified

		E3631A			E3632A Low Range/ High Range		E3633A Low Range/ High Range		E3634A Low Range/ High Range	
<b>dc outputs</b>	Voltage	0 to +25 V/	0 to -25 V/	0 to 6 V/	0 to 15 V, 7A/	0 to 8 V, 20A/	0 to 25 V, 7A/			
	Current	0 to 1 A	0 to 1 A	0 to 5 A	0 to 30 V, 4 A	0 to 20 V, 10 A	0 to 50 V, 4 A			
<b>Load and line regulation</b>	Voltage	<0.01% + 2 mV	<0.01% + 2 mV	<0.01% + 2 mV	<0.01% + 2 mV	<0.01% + 2 mV	<0.01% + 2 mV			
	Current	<0.01% + 250 $\mu$ A	<0.01% + 250 $\mu$ A	<0.01% + 250 $\mu$ A	<0.01% + 250 $\mu$ A	<0.01% + 250 $\mu$ A	<0.01% + 250 $\mu$ A			
<b>Ripple and noise</b> (20 Hz to 20 MHz)	Normal-mode voltage	<350 $\mu$ V rms/ 2 mV p-p	<350 $\mu$ V rms/ 2 mV p-p	<350 $\mu$ V rms/ 2 mV p-p	<350 $\mu$ Vrms/ 2mVpp	<350 $\mu$ Vrms/ 3mVpp	<500 $\mu$ Vrms/ 3mVpp			
	Normal-mode current	<500 $\mu$ A rms	<500 $\mu$ A rms	<2 mA rms	<2 mA rms	<2 mA rms	<2 mA rms			
	Common-mode current	<1.5 $\mu$ A rms	<1.5 $\mu$ A rms	<1.5 $\mu$ A rms	<1.5 $\mu$ A rms	<1.5 $\mu$ A rms	<1.5 $\mu$ A rms			
	<b>Programming accuracy</b> (25° C $\pm$ 5° C)	Voltage	0.05% + 20 mV	0.05% + 20 mV	0.1% + 5 mV	0.05% + 10 mV	0.05% + 10 mV	0.05% + 10 mV		
	Current	0.15% + 4 mA	0.15% + 4 mA	0.2% + 10 mA	0.2% + 10 mA	0.2% + 10 mA	0.2% + 10 mA			
<b>Readback accuracy</b> (25° C $\pm$ 5° C)	Voltage	0.05% + 10 mV	0.05% + 10 mV	0.1% + 5 mV	0.05% + 5 mV	0.05% + 5 mV	0.05% + 5 mV			
	Current	0.15% + 4 mA	0.15% + 4 mA	0.2% + 10 mA	0.15% + 5 mA	0.15% + 5 mA	0.15% + 5 mA			
<b>Resolution</b>	Program/	1.5 mV, 0.1 mA/	1.5 mV, 0.1 mA/	0.5 mV, 0.5 mA/	1 mV, 0.5 mA/	1 mV, 1 mA/	3 mV, 0.5 mA/			
	readback	1.5 mV, 0.1 mA	1.5 mV, 0.1 mA	0.5 mV, 0.5 mA	0.5 mV/0.1 mA	0.5 mV, 1 mA	1.5 mV, 0.5 mA			
	Meter	10 mV/1 mA	10 mV/1 mA	1 mV/1 mA	1 mV/1 mA	1 mV, 1 mA (<10A), 10 mA ( $\geq$ 10A)	1 mV/1 mA (<10A), 10 mA ( $\geq$ 10A)			
<b>Transient Response Time:</b> 50 $\mu$ sec for output to recover to within 15 mV following a change in output current from full load to half load or vice versa										

Indicates QuickShip availability.

### ac Input:

- 100 Vac  $\pm$  10%, 47 to 63 Hz (Option OE9)
- 115 Vac  $\pm$  10%, 47 to 63 Hz (Standard)
- 230 Vac  $\pm$  10%, 47 to 63 Hz (Option OE3)

**Product Regulation:** Certified to CSA 22.2 No. 231 (E3631A), No. 1010.1 (E3632A/33A/34A); conforms to IEC 1010.1; carries CE mark; complies with CISPR-11, Group 1, ClassA.

**Warranty:** Three years

**Size:** E3631A, 32A, 33A, 34A 132 mm H x 213 mm W x 348 mm D (5.2 in x 8.4 in x 13.7 in)

**Weight:** E3631A 8.2 kg (18 lb); E3632A, E3633A, E3634A 9.5 kg (21 lb)

### Ordering Information

- Standard** 115 Vac  $\pm$  10%, 47 to 63 Hz
- Opt OE3** 230 Vac  $\pm$  10% 47 to 63 Hz
- Opt OE9** 100 Vac  $\pm$  10% 47 to 63 Hz
- Opt 1CM** Rackmount Kit
- Opt 910** Extra manual

E3620A  
E3630A

- E3620A Features**
- Low noise, excellent regulation
  - Two isolated power supplies
  - Two digital meters
  - Linear power supply
  - 10-turn potentiometer

- E3630A Features**
- Triple output
  - Low noise, excellent regulation
  - Auto-tracking
  - Two digital meters
  - Linear power supplies

These multiple-output power supplies have 0.01% load and line regulation which keeps the outputs steady with changes of the power line and load. These supplies specify both normal-mode voltage noise and common-mode current noise. The low normal-mode noise specification of 350  $\mu$ V rms assures clean power for precision circuitry, and the low common-mode current specification of 1  $\mu$ A rms minimizes line frequency current injection.

Both power supplies have separate digital panel meters to monitor both the voltage and current of any output simultaneously. An LED indicator for each output lets the user know when any supply is overloaded. All the outputs on these models are protected against overload and short-circuit damage. Protection circuits prevent output voltage overshoot when supply is turned on and off. The +6 V output of E3630A employs current foldback; all others are current limited.

### E3630A

This general-purpose power supply provides three outputs, one 0 to 6 V output to power logic or other circuitry and one 0 to +20 V and 0 to -20 V to power linear circuits. The 0 to +20 V and 0 to -20 V outputs track to within 1%. The 0 to -20 V output can be set to any value less than the 0 to +20 V output. One voltage control may be used to vary both simultaneously.

The E3630A is 88 mm H x 213 mm W x 213 mm D (3.6 in x 8.4 in x 12.6 in) and weighs 3.8 kg (8.4 lbs).

### E3620A

This general-purpose power supply provides two separate, independent and isolated power supplies in one small package. Each output has a ten-turn potentiometer for fine adjustment. Convenient meter selection allows the user to read voltage and current of either output. Each output can deliver up to 25 watts.

The E3620A is 88 mm H x 213 mm W x 400 mm D (3.6 in x 8.4 in x 15.8 in) and weighs 5.5 kg (12.1 lb).

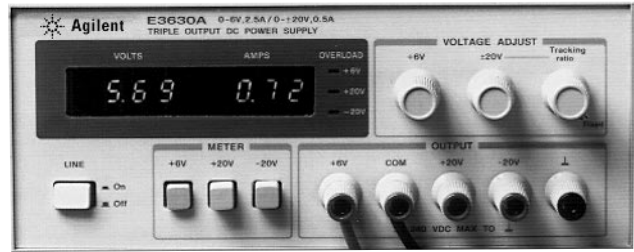

E3620A, E3630A

### Specifications at 0° C to 55° C unless otherwise specified

	E3620A	E3630A
<b>Number of outputs</b>	2	3
<b>Number of output ranges</b>	1	1
<b>Output ratings</b>	Output 1 Output 2 Output 3 Power (max.)	0 to 25 V, 0 to 1 A 0 to 25 V, 0 to 1 A 0 to -20 V, 0 to 0.5 A 35 W
<b>Load and line regulation</b>	0.01% +2 mV	0.01% +2 mV
<b>Ripple and noise</b>	rms peak-to-peak	350 $\mu$ V 1.5 mV
<b>Control mode</b>	CV/CL	CV/CL ( $\pm$ 20 V) CV/CF (+6 V)
<b>Resolution</b> (minimum change using front-panel controls)	Voltage Current	10 mV 1 mA 100 mV (>20 V)
		Indicates QuickShip availability.

\* Derate max., output current from 2.5 A at 6 V, to 1 A at 0 V.

Indicates QuickShip availability.

### Key Literature

2000/01 Agilent Technologies Power Products Catalog, p/n 5968-2199E  
Agilent GP Instruments Catalog, p/n 5968-8736

For more information, visit our web site:  
<http://www.agilent.com/find/power>

### Ordering Information

**Standard** 115 Vac  $\pm$  10%, 47 to 63 Hz  
**Opt 0E3** 230 Vac  $\pm$  10%, 47 to 63 Hz Input  
**Opt 0E9** 100 Vac  $\pm$  10%, 47 to 63 Hz Input  
For use in Japan

### E3610A, E3611A, and E3612A Features

- Dual ranges
- Digital voltage and current meters
- 10-turn potentiometer
- Linear power supply

### E3614A, E3615A, E3616A, and E3617A Features

- Digital voltage and current meters
- Front and rear output terminals
- Over-voltage protection
- Remote sensing
- Remote analog programming
- Linear power supply

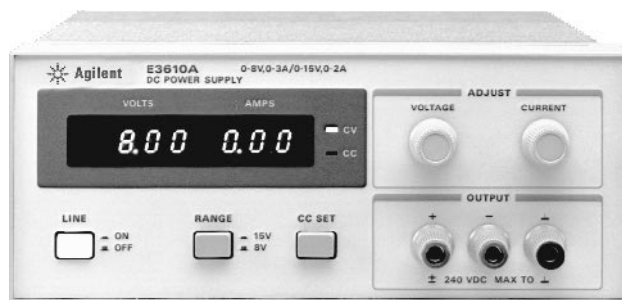

E3610A–E3617A

E3610A to E3617A

### E3610A, E3611A, E3612A

These popular low-cost CV/CC bench supplies are designed for general laboratory use. The constant-voltage, constant-current output allows operation as either a voltage source or current source. The changeover occurs automatically, based on the load. This feature also provides an adjustable current limit, allowing you to set the safest current limit level for a particular DUT. Also, a CC-set button lets you set the current limit without having to short the output.

Each model has two ranges, allowing more current at a lower voltage. For a higher-output voltage, supplies can be connected in series. Either the positive or negative terminal can be connected to ground, providing a positive or negative voltage output. Either terminal can also be floated up to 240 V from ground.

Dual digital meters monitor current and voltage simultaneously. Adjustments are made with the 10-turn voltage control and the 10-turn current control. Each power supply is 88 mm H x 212 mm W x 318 mm D (3.5 in x 8.4 in x 12.5 in) and weighs 3.8 kg (8.4 lb).

### E3614A, E3615A, E3616A, E3617A

These flexible single range CV/CC power supplies can be used as either voltage sources or current sources. The CC-set button allows you to quickly set the current limit when operating in the CV mode, without shorting the output. 10-turn controls allow accurate adjustment of voltage and current output settings. The output voltage and current can also be controlled with external 0 to 10 volt analog signals or variable resistance.

Output connections can be made on either the front or rear panel. Remote sensing is available to eliminate the errors in voltage regulation due to voltage drops in the load leads. Either the positive or negative output terminal may be connected to ground to provide positive or negative output voltage. Either terminal can also be floated to a maximum of 240 volts. Multiple units can be combined in auto-parallel, auto-series and auto-tracking configurations to obtain more voltage or current output.

The load is protected with the over-voltage protection feature, which is easily monitored and adjusted from the front panel. The digital voltage and current meters provide continuous and accurate readings of the output levels. The E3614A–E3617A are 88 mm H x 212 mm W x 373 mm D (3.5 in x 8.5 in x 14.7 in).

### Key Literature

2000/01 Agilent Technologies Power Products Catalog, p/n 5968-2199E  
Agilent GP Instruments Catalog, p/n 5968-4646

For more information, visit our web site:  
<http://www.agilent.com/find/power>

### Ordering Information

**Standard** 115 Vac ± 10%, 47 to 63 Hz  
**Opt 0E3** 230 Vac ± 10% 47 to 63 Hz  
**Opt 0E9** 100 Vac ± 10% 47 to 63 Hz

### Specifications at 0° C to 55° C unless otherwise specified

Single-output models		E3610A	E3611A	E3612A	E3614A	E3615A	E3616A	E3617A
<b>Number of output ranges</b>		2	2	2	1	1	1	1
<b>Output ratings<sup>1</sup></b>	Range 1	0 to 8 V, 0 to 3 A <sup>1</sup>	0 to 20 V, 0 to 1.5 A <sup>1</sup>	0 to 60 V, 0 to 0.5 A <sup>1</sup>	0 to 8 V, 0 to 6 A	0 to 20 V, 0 to 3 A	0 to 35 V, 0 to 1.7 A	0 to 60 V, 0 to 1 A
	Range 2	0 to 15 V, 0 to 2 A <sup>1</sup>	0 to 35 V, 0 to 0.85 A <sup>1</sup>	0 to 120 V, 0 to 0.25 A <sup>1</sup>	—	—	—	—
	Power (max.)	30 W	30 W	30 W	48 W	60 W	60 W	60 W
<b>Load and line regulation</b>		0.01%+2 mV	0.01%+2 mV	0.01%+2 mV	0.01%+2 mV	0.01%+2 mV	0.01%+2 mV	0.01%+2 mV
<b>Ripple and noise</b>	rms	200 μV	200 μV	200 μV	200 μV	200 μV	200 μV	200 μV
	peak-to-peak	2 mV	2 mV	2 mV	1 mV	1 mV	1 mV	1 mV

### Supplemental Characteristics Non-warranted characteristics determined by design and useful in applying the product

Control mode		CV/CC	CV/CC	CV/CC	CV/CC	CV/CC	CV/CC	CV/CC
<b>Resolution</b>	Voltage	10 mV	100 mV	100 mV	10 mV	10 mV (0-20 V) 100 mV (0-20 V)	10 mV (0-20 V) 100 mV (0-20 V)	10 mV (0-20 V) 100 mV (0-20 V)
	Current	10 mA	10 mA	1 mA	10 mA	10 mA	1 mA	1 mA
(minimum change using front-panel controls)								

<sup>1</sup>Maximum current is derated 1% per °C between 40° C to 55° C.

Indicates QuickShip availability.

6800 Series  
6811B  
6812B  
6813B  
6814B  
6834B  
6843A

- Versatile ac power test solutions
- Generate stable or distorted ac and dc power
- 50/60 Hz power up to 300 Vrms
- 400 Hz avionics power up to 300 Vrms
- Arbitrary waveform generation
- Built-in precision power analyzer
- Easy to integrate into ATE systems
- VXIplug&play drivers available

- SCPI (standard commands for programming instruments)
- Drop-in replacement—Elgar PIP9012 code built in
- Electronic calibration
- Full protection features (OV, OI, OP, OT)
- Three year warranty
- CE mark
- New FREE graphical user interface
- New dual power analyzer option



6811B, 6812B, 6813B, top; 6814B, 6834B, 6843A, bottom

## Powerful Direct Digital Synthesis (DDS) Waveform Generation

The 6800 series offers the ultimate in waveform generation versatility. For testing products under ac line distortion conditions, clipped sine waves can be generated with 0% to 43% distortion. There are a number of methods for creating waveforms some include inputting harmonic content, phase angles, and data points. These waveforms can be used to generate steady state outputs or can be combined for more complex transient generation schemes.

## Flexible Transient Generation

When testing requires precise synchronization between waveform generation and measurement of the device under test, the 6800 series transient generation capability provides a powerful tool. The output voltage amplitude, frequency, phase, waveform shape, voltage slew rate, and frequency slew rate can be controlled in response to an input trigger generated from an internal or external event. The Step and Pulse modes offer an easy and convenient method of executing single-step and continuous-output changes. The List transient mode further extends this capability for more complex waveform generation needs. Up to 100 sequences of output settings can be precisely executed in response to a trigger or paced by programmed dwell times without computer intervention.

## Extensive Measurement and Analysis

The 6800 series has measurement functionality equivalent to commercially available high-accuracy power analyzers. This eliminates the need for this standalone instrument for most applications, and lowers systems cost, increases available rack space, and simplifies cabling. All measurements are made with 16-bit resolution, suitable for even the most demanding applications.

The 6800 series has built-in voltage and current waveform digitization combined with harmonic analysis capability. Amplitude, phase, and total harmonic distortion results up to the 50th harmonic are provided for output frequencies equal to or less than 250 Hz. This measurement feature, accessible via the front panel graphical user interface software or over the bus, provides a sophisticated solution for testing during product development. A new dual power analyzer option (020) now provides the equivalent of two standalone power analyzers for measuring the input.

## AC Mains Regulatory Testing

Testing for ac mains emissions and immunity tests is now even easier. The 14760A series regulatory test solution (RTS) software can be used with 6812B, 6813B, and 6843A ac power solutions. This Windows based software provides a fast and easy way to set-up, perform and document tests.

## Multiple Interfaces

The 6800 series ac power solutions offer multiple programming interfaces for convenience. The front panel offers access to most commonly used commands, SCPI can be sent via GPIB or RS-232. The graphical user interface (GUI) that is shipped with every ac power solution provides easy access to the capabilities of the instrument. Key tests such as inrush characterization are set-up in templates to facilitate testing. In addition to saving waveforms in non-volatile memory, they can be saved in the GUI and quickly downloaded to the source.

## Key Literature

2000/01 Agilent Power Products Catalog, p/n 5968-2199E

For more information, visit our web site:  
<http://www.agilent.com/find/acpower>

## 6800 AC Power Solutions AC Power Sources/ Analyzers and Regulatory Test Solutions



<b>6811B</b>	300 V <sub>rms</sub> , 375 VA Single phase model	<b>6814B</b>	300 V <sub>rms</sub> , 3000 VA Single phase model
<b>6812B</b>	300 V <sub>rms</sub> , 750 VA Single phase model	<b>6834B</b>	300 V <sub>rms</sub> , 4500 VA <sub>total</sub> One/three phase model
<b>6813B</b>	300 V <sub>rms</sub> , 1750 VA Single phase model	<b>6843A</b>	230 V <sub>rms</sub> , 4000 VA <sub>total</sub> Single phase model

Agilent Technologies ac power source/analyzers are designed for applications which require precise control, accurate measurement, and analysis of single- and three-phase ac power. The feature set and performance levels of this product family provide the flexibility necessary to power and test a wide variety of devices. These products are ideal for applications such as power supply testing, AC Mains CE Mark Testing UPS testing, avionics, air traffic control equipment, testing power-factor-corrected equipment and telecom equipment.

The 6800 series utilizes a low noise switching topology, which delivers high performance and reduced size. These products can output dc, ac complex, and user-defined waveforms for exceptional application flexibility over the bus.

## Key Features

- High peak current capability
- Programmable voltage, frequency, phase, output impedance, distortion, and current limit
- Voltage and frequency slew control
- Power line disturbance simulation
- Avionics power disturbance simulation
- Measurement of Vrms, Irms, Ipeak, frequency, phase, VA, watts, PF, and THD
- Two current measurement ranges. Low range increases sensitivity 10:1 (6811B, 6812B, 6813B)
- Harmonic analysis of V and I
- Programmable 1 phase/3 phase mode (6834B)
- Built-in GPIB and RS-232 interfaces
- Built-in output isolation relays
- MIL-STD 704 and RTCA DO160 (Section 16) testing capability
- Built-in 26 Vrms AUX output option (6834B not available with Opt. 400)
- Remote shutdown via TTL signal
- dc output autoranging on 6811B, 6812B, 6813B
- Application specific options



**Supplemental Characteristics** Non-warranted characteristics determined by design that are useful in applying the product

	6811B	6812B <sup>1</sup>	6813B <sup>1</sup>	6814B	6834B	6843A
<b>Number of phases</b>	1	1	1	1	1/3	1
<b>Output ratings</b>						
Power	375 VA	750 VA	1750 VA	3000 VA	4500 VA	4800 VA
Maximum rms voltage	300 V	300 V	300 V	300 V (high range) 150 V (low range)	300 V	300 V
Maximum rms current	3.25 A	6.5 A	13 A	10 A (high range) 20 A (low range)	15 A/5A 30 A/10 A	32 A
Maximum repetitive peak current	40 A	40 A	80 A	40 A (high range) 80 A (low range)	60 A/20A (high range) 120 A/40 A (low range)	48 A (high range) 96 A (low range)
Crest factor	12	6	6	5	6.7	3
Output frequency range	dc; 45 to 1kHz	dc; 45 to 1kHz	dc; 45 to 1kHz	dc; 45 to 1kHz	dc; 45 to 1kHz	dc; 45 to 1kHz
dc power (watts)	285 W	575 W	1350 W	–	–	–
dc voltage	± 425 V	± 425 V	± 425 V	–	–	–
dc current	2.5 A	5 A	10 A	–	–	–

**Measurement Accuracy** (25 ± 5 dec C) from 45–100 Hz in High range where applicable

Output ratings	Rms voltage	0.03% +100mV	0.03% +100mV	0.03% +100mV	0.05% +250mV	0.05% +250mV	0.05% +250mV
Rms current	0.05% + 10 mA	0.05% + 10 mA	0.05% + 10 mA	0.01% + 50 mA	0.01% + 50 mA	0.01% + 25 mA (in 3 phase)	0.01% + 75 mA
Power (VA)	0.1% + 1.5 VA +12 mVA/V	0.1% + 1.5 VA +12 mVA/V	0.1% + 1.5 VA +12 mVA/V	0.15% + 5 VA	0.15% + 5 VA	0.15% + 3 VA (in 3 phase)	0.15% + 9 VA
Power (Watts)	0.1% + 0.3 W + 1.2 mW/V	0.1% + 0.3 W + 1.2 mW/V	0.1% + 0.3 W + 1.2 mW/V	0.15% + 5 W	0.15% + 5 W	0.15% + 3 W (in 3 phase)	0.15% + 9 W

**Regulatory Test Solution** IEC mode measurement system characteristics

<b>Output frequency range</b>	–	50/60 Hz	50/60 Hz	–	–	–
<b>Reference impedance accuracy</b>	–	3% ( at 0.4 Ω and 796 uH)	3% ( at 0.4 Ω and 796 uH)	–	–	3% ( at 0.4 Ω and 796 uH)
<b>Maximum total harmonic distortion</b>	–	0.25%	0.25%	–	–	0.1%
<b>Measurement accuracy</b>						
<b>Current magnitude (low range)</b>						
Fundamental	0.03% + 1.5 mA	0.03% + 1.5 mA	–	–	–	0.03% + 3 mA
Harmonics 2–49	0.03% + 1mA + 0.2%/kHz	0.03% + 1mA + 0.2%/kHz	–	–	–	0.03% + 2 mA + 0.2%/kHz
<b>Current magnitude (high range)</b>						
Fundamental	0.05% + 5 mA	0.05% + 5 mA	–	–	–	0.05% + 6 mA
Harmonics 2–49	0.05% + 3mA + 0.2%/kHz	0.05% + 3mA + 0.2%/kHz	–	–	–	0.05% + 3 mA + 0.2%/kHz

<sup>1</sup>Regulatory test ready.<sup>2</sup>14761A Harmonic and Flicker Emissions Test Software bundled in to 6843A price.

**Remote Sensing:** Up to 10 Vrms can be dropped across each load lead.  
**Command Processing Time:** The average time for the output rms voltage to start to change after receiving a GPIB command is 10 milliseconds.  
**Calibration Interval:** One year  
**GPIB Capabilities:** SH1, AH1, T6 L4, SR1, RL1 PPO, DC1, DT1, E1, and CO, and a command set compatible with IEEE-488.2 and SCPI  
**Regulatory Compliance:** Listed to UL-1244; certified to CSA 22.2 No. 231; complies with EN61010-1  
**RFI Suppression:** Complies with CISPR-11, Group 1, Class A

**Ordering Information**

**14761A** Harmonic and Flicker Emissions Tests Software  
**14762A** Voltage and Frequency Disturbances Immunity Tests Software  
**14763A** Interharmonics Test Software  
**14769A** All the 14760A Series Test Software  
**Support rails** (p/n 1494-0059E) required when rackmounting the 6812B and 6813B Opt 1CM and Opt 1CP  
**Support rail kit E3664AC** must be ordered with Opt 1CM for rackmounting the 6814B, 6834B, and 6843A

A line cord option must be specified. For details, refer to page 192.

**Accessories**

**p/n 5060-3513** Three 30-A replacement fuses for 6814B/34B/43A  
**p/n 5063-2310** Heavy-duty rack slide kit (6814B/34B/43B)

6800 Series  
 6811B  
 6812B  
 6813B  
 6814B  
 6834B  
 6843A

4

**Oscilloscopes**

General Purpose Instruments Catalog  
[5968-8736EUS/EN](#)

54645D Mixed Signal Oscilloscope  
 Data Sheet  
[5968-2610EN/EUS](#)

TDR Using the 54750A (CD-ROM)  
[5968-2517E](#)

54750A High-Bandwidth Digitizing Oscilloscope  
[5962-0097E](#)

Infiniium Voice Control Kit  
[5968-6659EN/EUS](#)

Infiniium DCA 86100A Wide-Bandwidth  
 Oscilloscope Technical Specifications  
[5968-8546E](#)

Infiniium DCA/In the Complex World of  
 High-Speed Data Transmission Accurate  
 Waveform Measurements Are Fast  
 and Simple  
[5968-8548E](#)

10 Methods for Faster High-Speed Digital  
 Communications Design Brochure  
[5968-4258E](#)

Agilent 54600 Series Oscilloscopes  
[5968-5316EN/EUS](#)

Infiniium Brochure  
[5968-9547EN/EUS](#)

8 Hints for Debugging Microcontroller-Based  
 Designs  
[5968-0943EN/EUS](#)

Agilent 54615B, 54616B/C Oscilloscopes  
[5968-7292EN/EUS](#)

Agilent Technologies 54600 Series Oscilloscopes,  
 Probes, & Accessories  
[5968-8153EN/EUS](#)

Agilent Technologies 54600 Series Oscilloscopes  
[5968-8152EN/EUS](#)

**Oscilloscope Probes & Accessories**

The Agilent Wedge: A Hands-Free Solution for  
 Probing Fine Pitch ICS  
[5968-7142E](#)

General Purpose Instruments Catalog  
[5968-8736EUS/EN](#)

N1020A TDR Probe  
[5968-4811](#)

Two-Channel, 750 MHz, Small-Geometry Active  
 Probe for Surface-Mount Devices  
[5968-3853E](#)

1180/81/82A Testmobile Data Sheet  
[5091-2520E](#)

Probes and Accessories for Infiniium Oscilloscopes  
[5968-7141 EN/EUS](#)

**Logic Troubleshooting Tools**

54620 A/C Logic Analyzer Data Sheet  
[5968-2614EN/EUS](#)

LogicDart Advanced Logic Probe E2310A  
 Data Sheet  
[5966-0434EN/EUS](#)

**Electronic Counters**

4 Hints for Making Better Microwave Counter  
 Measurements  
[5967-6195E](#)

8 Hints for Making Better RF Counter  
 Measurements  
[5967-6038E](#)

General Purpose Instruments Catalog  
[5968-8736EUS/EN](#)

**Digital Multimeters**

General Purpose Instruments Catalog  
[5968-8736EUS/EN](#)

34401A Digital DMM Data Sheet  
[5968-0162EN/EUS](#)

3458A 8½ Digital DMM Technical Data  
[5965-4971E](#)

**Data Acquisition & Switching**

34970A Data Acquisition/Switch Unit Product  
 Overview  
[5965-5290EN/EUS](#)

**Function Generators & Waveform Synthesizers**

General Purpose Instruments Catalog  
[5968-8736EUS/EN](#)

33120A 15 MHz Function/Arb Generator  
 Data Sheet  
[5968-0125EN/EUS](#)

**Software**

General Purpose Instruments Catalog  
[5968-8736EUS/EN](#)

**Digital Timing Analyzers**

Dynamic Frequency and Jitter Analysis at the Touch of a Button  
[5966-4093E](#)

Simplify Jitter and Wander Analysis with Time Interval Analyzer Solutions  
[5968-1605E](#)

Ensure Your Network Conforms to the Latest Synchronization Standards  
[5965-6659E](#)

Characterize and Reduce Clock Jitter to Improve System Speed and Reliability  
[5968-0108E](#)

Increase Your Confidence in SONET/SDH Integration with Existing Networks  
[5967-6288EE](#)

Capture and Analyze the Timing of Every Edge to Improve Margin  
[5967-6285EE](#)

**DC Electronic Loads**

Power Products Catalog  
[5968-2199EN/EUS/E](#)

Agilent Systems Power Products Selection Guide  
[5968-2197EN/EUS/END/EGB](#)

(PN) Zero Volt Electronic Load  
[5968-6360E](#)

**Power Supplies**

General Purpose Instruments Catalog  
[5968-8736EUS/EN](#)

Power Products Catalog  
[5968-2199EN/EUS/E](#)

Agilent Systems Power Products Selection Guide  
[5968-2197EN/EUS/END/EGB](#)

E4350A, E4351A Solar Array Simulator  
[5966-0711EN/EUS](#)

E4356A Telecommunication DC Power Supply  
[5968-6603E](#)

(PN 6285A) MPEG-2 Digital Video Encoder Stress Test Patterns—E6285A  
[5965-6492E](#)

(PN 66000) 66000 Modular Power System  
[5091-2497E](#)

Agilent Technologies E3640A–E3649A Programmable DC Power Supplies  
[5968-7355EN/EUS](#)

Agilent Technologies 3600 Series Manual Power Supply  
[5968-9727EN/EUS](#)

**AC Power Source/Analyzers**

Agilent Regulatory Test Solution  
[5968-1435EN/EUS](#)

(PN) Testing Uninterruptible Power Supplies  
[5967-6056E](#)

(PN) 6800 Series AC Power Source/Analyzer  
[5963-7044E](#)

Application Note 1273, Regulatory Testing  
[5964-1917E](#)

Power Products Catalog  
[5968-2199EN/EUS/E](#)

Agilent System Power Products Selection Guide  
[5968-2197EN/EUS/END/EGB](#)

**Signal Sources** Agilent Technologies offers the widest variety of signal generators from dc to 110 GHz. They cover every application from low-frequency navigation signals, through cellular mobile radio, to millimeter-wave satellite systems. A variety of modulations are available, as well as pulse and digital formats for testing the latest communications systems.

**Signal Analyzers** These instruments provide frequency-domain, time-domain, and modulation-domain measurement capability. Some of the key measurements that can be made with a signal analyzer are absolute and relative frequency, absolute and relative amplitude, scalar, noise, distortion products, amplitude modulation (AM), frequency modulation (FM), pulsed RF, and digital modulation.

**Network/Spectrum Analyzers** These analyzers are high-performance, cost-effective, intelligent analyzers with combined vector network and spectrum analysis capabilities.

**Network Analyzers** Vector network analyzers accurately characterize the linear and nonlinear electrical performance of components and circuits. They measure the effect of devices on the amplitude and phase of swept-frequency and swept-power test signals. Network analyzers provide the ability to measure the input characteristics of each port of a device as well as the transfer characteristics from one port to another.

**Power Meters** New generation power meters and sensors feature DSP technology, fast measurement speed, improved absolute accuracy and repeatability, and ease of use and portability. Full-featured models are available for MMS and VXI systems.

**Noise Figure Products** Automatic noise figure solutions provide accurate and simple measurement of noise figure and gain, with special modes to support the measurement of frequency translating devices. Characterize the performance of your receiver and receiver components, with standard solutions to 26.5 GHz and custom solutions to 110GHz.

**RF and Microwave Test Accessories** Agilent Technologies offers a complete line of RF and microwave test accessories for use in test and measurement systems from dc to 110 GHz. Products include step and fixed attenuators, amplifiers, detectors, couplers, switches, switch drivers, adapters, and waveguide devices.

Economy RF Signal Generators  
Digital I/Q Modulation  
High-Performance RF Signal  
Generators  
CW Microwave Sources  
High-Performance Microwave  
Sources  
Swept Frequency Microwave Sources

Spectrum Analyzers  
Dynamic Signal Analyzers  
Distortion and Audio Analyzers  
Vector Signal Analyzers  
Modulation Analyzers  
Measuring Receivers  
Modulation Domain Analyzers

RF Network  
Spectrum  
Impedance Analyzer  
Baseband  
IF Network  
Spectrum Analyzers

RF Network Analyzers  
Microwave Network Analyzers  
Scalar Network Analyzers  
S-Parameter Test Sets  
Vector Voltmeters

Power Meters  
Power Sensors  
EPM Power Meters  
E-Series Power Sensors  
Peak Power Meters  
MMS and VXI Power Meters

Automatic Noise Figure Meter  
Microwave Noise Figure  
Measurement System  
Noise Figure Test Set  
Broadband Noise Sources



*See also*  
 MMS Products 90  
 Electronic Counters 137

**Signal Sources 196**

**Signal Analyzers 227**

*See also*  
 Oscilloscopes 106  
 Network/Spectrum  
 Analyzers 266  
 Cellular/PCS Transmitter & Receiver  
 Test Equipment 379  
 Regulatory Test Equipment 513  
 Broadcast TV Analyzers 516

**Network/Spectrum Analyzers 266**

**Network Analyzers 271**

*See also*  
 Spectrum Analyzers 472  
 Component Analyzers 478  
 Component Test  
 Instruments 482  
 Materials Test Equipment 491

**Power Meters 303**

*See also*  
 VXIbus Products 93

**Noise Figure Analyzers 310**

**Amplifiers 315**

**RF & Microwave Test  
 Accessories 318**

*See also*  
 Oscilloscopes 106

**Additional Literature 331**



Agilent Technologies offers the widest selection of high-performance signal sources from dc to 110 GHz. They cover every application range from low-frequency navigation signals, through cellular mobile radio, to millimeter wave satellite systems. Each offers synthesized frequency accuracy and stability as well as calibrated level and remote programmability.

Modulation capabilities range from general purpose AM,  $\Phi$ M, FM, pulse, and I/Q modulation to specific formats such as GSM, EDGE, and CDMA.

For more information, visit our web site:  
[http://www.agilent.com/find/signal\\_sources](http://www.agilent.com/find/signal_sources)

## Signal Sources

### Analog RF Signal Generators

Frequency	Model	Characteristics	Page
0.1 to 1000 MHz	8648A	Economy signal generator family. $\pm 1$ dB level accuracy up to 2.5 GHz. The 8648 series provides good frequency range coverage, residual FM, level accuracy and phase noise, in addition to optional high power, pulse, and waveform modulation. All four models offer variable frequency modulation generator (Option 1E2). Electronic attenuator on 8648A.	200
0.009 to 2000 MHz	8648B		
0.009 to 3200 MHz	8648C		
0.009 to 4000 MHz	8648D		
0.25 to 1000 MHz	E4400B	ESG-A series analog signal generator platform. Superior level accuracy. Step sweep (frequency, power, and list). Electronic attenuator to 4 GHz. Built-in function generator. Flexible architecture for upgrade paths.	202
0.25 to 2000 MHz	E4420B		
0.25 to 3000 MHz	E4421B		
0.25 to 4000 MHz	E4422B		
0.25 to 1000 MHz	E4423B	ESG-AP series analog signal generator platform. All the same great features of the ESG-A, plus superior spectral purity from: $< -138$ dBc/Hz at 500 MHz to $< -122$ dBc/Hz at 4000 MHz (typical).	202
0.25 to 2000 MHz	E4424B		
0.25 to 3000 MHz	E4425B		
0.25 to 4000 MHz	E4426B		

### Digital RF Signal Generators

0.25 to 1000 MHz	E4430B	ESG-D series digital and analog signal generator platform. Excellent modulation accuracy and stability. Analog I and Q. Optional digital modulation formats include W-CDMA, cdma2000, and EDGE. Data generation and burst capabilities.	205
0.25 to 2000 MHz	E4431B		
0.25 to 3000 MHz	E4432B		
0.25 to 4000 MHz	E4433B		
0.25 to 1000 MHz	E4434B	ESG-DP series digital and analog signal generator platform. All the same great features of the ESG-D, plus superior spectral purity: $< -138$ dBc/Hz at 500 MHz to $< -122$ dBc/Hz at 4000 MHz (typical).	205
0.25 to 2000 MHz	E4435B		
0.25 to 3000 MHz	E4436B		
0.25 to 4000 MHz	E4437B		

### High-Performance RF Signal Generators

0.252 to 1030 MHz	8643A	Performance signal generator for RF design. $< -130$ dBc/Hz @ 1 GHz SSB phase noise 8643A: $< -137$ dBc/Hz 8644B. $< -100$ dBc spurious. AM, FM, and pulse modulation. Advanced modulation source. Lowest specified leakage. Avionics option available (Option 009).	209
0.252 to 2060 MHz	8644B		
0.01 to 1280 MHz	8662A	Low close-in noise. 0.1 Hz frequency resolution, $5 \times 10^{-10}$ /day stability. Calibrated and leveled output from +13 to -140 dBm. Digital sweep. Completely GPIB programmable. AM and FM. Fast switching.	211
0.1 to 2560 MHz	8663A	Low close-in noise with complex modulation. 0.1 Hz frequency resolution, $5 \times 10^{-10}$ /day stability. Calibrated and leveled output from +16 to -130 dBm. Digital sweep. Completely GPIB programmable. AM, $\Phi$ M, FM, and pulse modulation. Fast switching.	211
0.1 to 3000 MHz	8664A	Performance signal generators for 3.0 GHz, 4.2 GHz, and 6 GHz testing. Excellent spectral purity. AM and FM. High-performance pulse modulation. Advanced modulation source.	209
0.1 to 4200 MHz	8665A		
0.1 to 6000 MHz	8665B		
0.252 to 1030 MHz	8645A	Performance signal generator for testing frequency-agile radios and surveillance receivers. 15 $\mu$ s switching speed. Spectral purity. AM, FM, pulse modulation. FM deviation to 20 MHz. Flexible control of frequency.	223
0.252 to 2060 MHz	8645A		

**CW Microwave Sources**

Frequency	Model	Characteristics	Page
1 to 20 GHz	83711B	Precision CW signals, pure and simple. +10 to –90 dBm, < –50 dBc harmonics, < 1.5 x 10 <sup>-9</sup> /day stability, optional 1 Hz frequency resolution. Noise figure meter and millimeter source module compatible. GPIB and SCPI programming. < 15.9 kg (35 lb)	214
0.01 to 20 GHz	83712B		

**High-Performance Microwave Sources**

1 to 20 GHz	83731B	Optimum choice for high-performance microwave receiver and subsystem test. +10 to –90 dBm, harmonics < –55 dBc, spurious < –60 dBc, < 1.5 x 10 <sup>-9</sup> /day stability, optional 1 Hz frequency resolution. Built-in multi-mode pulse generator, <10 ns pulse rise/fall time, < 25 ns pulse width. Logarithmic AM with > 60 dB depth. FM with >300 modulation index 10 MHz peak deviation. GPIB and SCPI programming. < 15.9 kg (35 lb).	214
0.01 to 20 GHz	83732B		
0.01 to 50 GHz	8360B Series	Versatile synthesized sweeper. Covers many application needs, including signal simulation with pulse, scan, amplitude, and frequency modulation requirements. General-purpose sweeper with full network analyzer capability.	221
0.01 to 20 GHz	E6432A	VXI microwave synthesizer. Optimized for system use with extensive triggering and synchronizing modes, plus a list mode supporting 128k entries. Frequency switching time is under 400 μs regardless of frequency change. Maximum continuous power out (2–20 GHz) is +20dBm. Module is C-size, 3 slots, and register based.	216

**Swept Frequency Microwave Sources**

0.01 to 20 GHz	83751A/B 83752A/B	Synthesized microwave sweeper. Fully synthesized sweep. Continuous analog or digital step sweep, 2 MHz swept frequency accuracy, +17 dBm output power available. SCPI and GPIB programmable, 8350 GPIB mnemonics for drop-in replacement. Optimized for 8757 scalar network analyzers.	219
0.01 to 50 GHz	8360L Series	General-purpose synthesized swept CW generator with full network analyzer compatibility. +15 dBm output power available.	221

**High-Performance VXI**

.01 to 20 GHz	E6432A	VXI Microwave Synthesizer. High-performance microwave synthesizer in three C-size slots. Fast-switching architecture is register-based. Amplitude range –20 to +17 dBm, optionally –90 to +20 dBm. AM, FM, and pulse modulation. I/Q modulation available with Option UNG. 1 Hz frequency resolution. Exceptional spectral purity and spurious performance. Optimized for system use with deep list mode (128k entries), full triggering, and synchronization.	216
.01 to 20 GHz	E7501A	Analog Simulation and Generation Subsystem. The 4-slot VXI-based microwave stimulus system consists of a 3-slot high-performance VXI microwave synthesizer, a 1-slot multi-channel VXI arbitrary waveform generator, and Agilent Technologies Signal Studio Analog Generation and Simulation software. System also includes a PC with WindowsNT and IEEE 1394 VXI interface.	218

**Frequency-Agile/Complex Signal Simulation**

0.252 to 1030 MHz 0.252 to 2060 MHz	8645A	Performance signal generator for testing frequency-agile radios and surveillance receivers. 15 μs switching speed. Spectral purity. AM, FM, pulse modulation. FM deviation to 20 MHz. Flexible control of frequency.	223
--	-------	--	-----

**Millimeter Modules**

26.5 to 40 GHz	83554A	Efficient frequency multipliers. Effectively extends the performance of an 11 to 20 GHz microwave source 8673B/C/D, 8340, 8341, 8350B, 83751/52, or 8360 to the millimeter-wave frequency ranges.	225
33 to 50 GHz	83555A		
40 to 60 GHz	83556A		
50 to 75 GHz	83557A		
75 to 110 GHz	83558A		

8648A  
8648B  
8648C  
8648D

- ±1 dB level accuracy through 2.5 GHz
- 4 Hz residual FM at 500 MHz
- Electronic attenuator (1 GHz models)
- +10/+13 to -136 dBm output power
- Simple, dependable operation
- Pager signaling (8648A Option 1EP)



8648A/B/C/D

### 8648A/B/C/D Synthesized Signal Generators ▶ GPIB

#### Superior Value in Economy Signal Generators

The 8648A/B/C/D family of synthesized signal generators delivers solid performance and reliability at an affordable price. These signal generators provide the features and performance needed for semi-automated receiver testing and for use in a variety of general-purpose applications over a 9 kHz to 4000 MHz frequency range.

#### High Reliability and Simplicity

Designed to Agilent's stringent quality specifications, these signal generators provide consistent performance. The all-electronic attenuator in the 8648A easily handles millions of amplitude cycles with highly repeatable output levels.

An easy-to-use front panel interface shortens the operator's learning curve and increases productivity. A front panel organized in functional blocks speeds identification of the task and simplifies operation.

#### Ideal for Manufacturing and Semi-Automated Test

The 8648 series are ideal for manufacturing high-volume products such as cordless telephones, pagers and two-way radios. The Agilent 8648 series provides good frequency range coverage, residual FM, level accuracy and phase noise, in addition to optional high power, pulse modulation and waveform modulation. The Agilent 8648 series provides ±1 dB absolute amplitude accuracy up to 2.5 GHz. All of the models offer ultra stable dc FM, with ±500 Hz carrier frequency accuracy below frequencies of 1001 MHz, and low RF leakage.

Applications such as receiver tuning and alignment benefit from the simple user interface. These signal generators are so easy to learn and use that experienced operators are no longer required. With 300 full storage registers and ten user-definable sequences, the signal generator easily adapts to any test procedure. Once setups are stored in registers, operators can quickly sequence through them, either from the front panel or through a remote keypad (83300A). In addition, the 83301A memory interface provides the means to transfer register information from one 8648 to another.

For automated test applications, the 8648 offers full GPIB programmability and uses SCPI programming codes. In addition, the 8648 series reduces software development costs by providing full GPIB code compatibility with the 8656B and 8657A/B signal generators.

#### New Cost-Effective Pager Testing

The 8648A with Option 1EP provides an economical, one-box solution for pager test. Option 1EP adds the pager encoding capability for POC-SAG, FLEX, and FLEX-TD formats to the 8648A. Ideal for pager test applications, the 8648A with Option 1EP offers superior frequency accuracy, deviation accuracy, and dc FM performance.

### Specifications

#### Frequency

- 8648A: 100 kHz to 1000 MHz
- 8648B: 9 kHz to 2000 MHz
- 8648C: 9 kHz to 3200 MHz
- 8648D: 9 kHz to 4000 MHz

#### Resolution

8648A/B/C/D: 0.001 Hz

Display: 10 Hz

#### Switching Speed (typical)

8648A/B/C/D: < 1001 MHz: < 75 ms; ≥ 1001 MHz: < 100 ms

**Accuracy** (after one hour warm-up and within one year calibration): Typically ± 3 × 10<sup>-6</sup> × carrier frequency in Hz, ± 0.15 × 10<sup>-6</sup> × carrier frequency in Hz for Option 1E5 (typically ± 0.072 × 10<sup>-6</sup> × fc)

#### Internal Reference Oscillator

**Accuracy and Stability** (calibration adjustment dependent; after one hour warm-up and within one year of calibration), ± aging rate ± temperature effects ± line voltage effects

	Standard Timebase	Option 1E5
<b>Aging</b>	< ± 2 ppm/yr	< ± 0.1 ppm/yr; < ± 0.0005 ppm/day
<b>Temperature</b>	< ± 1 ppm	< ± 0.01 ppm (typ.)
<b>Line Voltage (± 5%)</b>	< ± 0.5 ppm	N/A

**Output:** 10 MHz, typically > 0.5 V<sub>rms</sub> into 50 Ω

**External Reference Oscillator Input:** Accepts 2, 5, 10 MHz ±5 ppm and a level range of 0.5 V to 2 V<sub>rms</sub> into 50 Ω

#### Spectral Purity

**Harmonics** (output ≤ 4 dBm): < -30 dBc

**Subharmonics** (output ≤ +4 dBm) < 1001 MHz: -60 dBc; ≥ 1001 MHz: -50 dBc; > 3200 MHz: -40 dBc

**Nonharmonics** (≥ 5 kHz offset, ≤ +4 dBm output level)

#### 8648A/B/C/D

< 249 MHz: < -55 dBc; < 2001 MHz: < -54 dBc

< 1001 MHz: < -60 dBc; ≤ 4000 MHz: < -48 dBc

#### Residual FM (CCITT, rms)

#### 8648A/B/C/D

< 249 MHz: < 7 Hz, typically < 4 Hz

< 501 MHz: < 4 Hz, typically < 2 Hz

< 1001 MHz: < 7 Hz, typically < 4 Hz

< 2001 MHz: < 14 Hz, typically < 8 Hz

≤ 4000 MHz: < 28 Hz, typically < 12 Hz

#### SSB Phase Noise (at 20 kHz offset, typical)

#### 8648A/B/C/D

@ fc 500 MHz: < -120 dBc/Hz; @ fc 3000 MHz: < -106 dBc/Hz

@ fc 1000 MHz: < -116 dBc/Hz; @ fc 4000 MHz: < -104 dBc/Hz

@ fc 2000 MHz: < -110 dBc/Hz

#### Output Range

8648A: +10 to -136 dBm

8648B/C/D: ≤ 2500 MHz: +13 to -136 dBm;

> 2500 MHz: +10 to -136 dBm

#### Max. Power with Option 1EA (High Power) on 8648B/C/D only

Freq. (MHz)	< 0.1	≤ 1000	≤ 1500	≤ 2100	≤ 2500	≤ 4000
<b>Power (dBm)</b>	+17	+20	+19	+17	+15	+13

#### Display Resolution: 0.1 dB

**Accuracy** (specified power < 13 dBm to -127 dBm)

8648A/B/C/D (applies at 25° ± 5° C):

≤ 2500 MHz: ± 1.0 dB

≤ 3200 MHz: ± 1.5 dB (≥ -100 dBm; ± 3.0 dB < -100 dBm)

≤ 4000 MHz: ± 2.0 dB (≥ -100 dBm; ± 3.0 dB < -100 dBm)

#### Reverse Power Protection (watts into 50 Ω)

8648A/B: 50 watts

8648C/D: 50 watts ≤ 2000 MHz; 25 watts > 2000 MHz



**SWR:** (output < -6 dBm, typical)

**8648A/B/C/D:**

- < 249 kHz: < 2.5:1
- ≤ 2500 MHz: < 1.5:1
- ≤ 3200 MHz: < 2.0:1

**Output Impedance:** Nominally 50 Ω

### Frequency Modulation

**Peak Deviation**

(rates > 25 Hz ac FM)

**8648A/B/C/D**

< 249 MHz	0 to 200 kHz
< 501 MHz	0 to 100 kHz
< 1001 MHz	0 to 200 kHz
< 2001 MHz	0 to 400 kHz
≤ 4000 MHz	0 to 800 kHz

**Resolution**

**For ≤ 10% peak deviation**

- < 2001 MHz: 10 Hz
- ≥ 2001 MHz: 20 Hz

**For > 10% to maximum peak deviation**

- < 2001 MHz: 100 Hz
- ≥ 2001 MHz: 200 Hz

**Deviation Accuracy** (internal 1 kHz rate)

**8648A/B/C/D**

- < 1001 MHz: ± 3% of deviation ± 30 Hz
- < 2001 MHz: ± 3% of deviation ± 60 Hz
- ≤ 4000 MHz: ± 3% of deviation ± 120 Hz

**8648A Option 1EP only:**

- 50 Hz at 276 to 284 MHz, 406 to 512 MHz, and 929 to 932 MHz

**Rates**

**8648A/B/C/D**

- Internal: 400 Hz to 1 kHz (10 Hz to 20 kHz for Option 1E2)
- External dc: dc to 150 kHz (typical, 3 dB BW)
- External ac: 1 Hz to 150 kHz (typical, 3 dB BW)

**Distortion** (1 kHz rate, THD + N, 0.3 to 3 kHz BW)

- < 1001 MHz: < 1% at deviations > 4 kHz
- < 2001 MHz: < 1% at deviations > 8 kHz
- ≤ 4000 MHz: < 1% at deviations > 16 kHz

**8648A/B/C/D** 88 to 108 MHz: < 0.5% at deviations ≥ 75 kHz

**Carrier Frequency Accuracy** (relative to CW in dc FM, at 25° ± 5° C)

- < 1001 MHz: ± 100 (typ. 40°) Hz, deviations < 10 kHz
- < 2001 MHz: ± 200 (typ. 80°) Hz, deviations < 20 kHz
- ≤ 4000 MHz: ± 400 (typ. 160°) Hz, deviations < 40 kHz

**FM + FM:** Internal 1 kHz to 400 Hz source plus external. In internal plus external FM mode, the internal source produces the set level of deviation. The external input should be set to ≤ ±0.5 V peak or 0.5 Vdc (one-half the set deviation).

### Phase Modulation

**Peak Deviation**

- < 249 MHz: 0 to 10 radians
- < 501 MHz: 0 to 5 radians
- < 1001 MHz: 0 to 10 radians
- < 2001 MHz: 0 to 20 radians
- ≤ 4000 MHz: 0 to 40 radians

**Resolution**

- < 2001 MHz: 0.01 radian
- ≥ 2001 MHz: 0.02 radian

**Deviation Accuracy** (internal 1 kHz rate, typical)

**8648A/B/C/D**

- < 1001 MHz: ± 3% of deviation ± 0.05 radians
- < 2001 MHz: ± 3% of deviation ± 0.1 radians
- ≤ 4000 MHz: ± 3% of deviation ± 0.2 radians

**Rates**

- Internal: 400 Hz or 1 kHz (10 Hz to 20 kHz for Option 1E2, 8648A/B/C/D only)
- External: 20 Hz to 10 kHz (typical, 3 dB BW)

**Distortion** (1 kHz rate)

**8648A/B/C/D**

- < 1001 MHz: < 1% at deviations ≥ 3 radians
- < 2001 MHz: < 1% at deviations ≥ 6 radians
- ≤ 4000 MHz: < 1% at deviations ≥ 2 radians

\*Within one hour after dc FM calibration

### Amplitude Modulation

(AM is not specified below 1.5 MHz and is typical above 1001 MHz.)

**Range:** 0 to 100%; output ≤ +4 dBm

**Resolution:** 0.1%

**Accuracy** (1 kHz rate): ± 5% of setting ± 1.5% (for 8648B/C/D, specification is applicable at 25° ± 5° C and < 70% depth)

**Rates**

- Internal: 400 Hz or 1 kHz (10 Hz to 20 kHz for Option 1E2, 8648A/B/C/D only)
- External dc: dc to 25 kHz (typical, 3 dB BW)
- External ac: 1 Hz to 25 kHz (typical, 3 dB BW)

**Distortion** (1 kHz rate, THD + N, 0.3 to 3 kHz BW)

**8648A:** @ 30% AM: < 2%; @ 90% AM: < 3%

**8648B/C/D:** @ 30% AM: < 2%; @ 70% AM: < 3%

**Pager Test Option 1EP (8648A only)**

**Signaling Formats:** POCSAG, FLEX, and FLEX-TD (RCR-43)

**Pulse Option 1E6 (8648B/C/D only)**

**On/Off Ratio:** > 80 dB < 2000 MHz; > 70 dB ≥ 2000 MHz

**Rise/Fall Times:** < 10 ns

**Modulation Generator Option 1E2 (8648A/B/C/D only)**

Adds variable frequency modulation generator.

**Frequency Range**

- Sine: 10 Hz to 20 kHz
- Square, Triangle, Sawtooth: 100 Hz to 2 kHz

**Frequency Accuracy:** ± 0.01% typical

**Frequency Resolution:** 1 Hz (3 digits displayed)

**Modulation Source**

**Internal:** 400 Hz or 1 kHz, front panel BNC connector provided at nominally 1 V (p-p) into 600 Ω

**External:** 1 V peak into 600 Ω (nominal) required for full scale modulation. (High/Low indicator provided for external signals ≤ 10 kHz.)

**Remote Programming**

**Interface:** GPIB (IEEE-488.2-1987) with Listen and Talk

**Control Languages:** SCPI version 1992.0. The 8648A/B/C/D are code compatible with the 8656B and 8657A/B.

**Functions Controlled:** All front panel functions except power switch and knobs

**IEEE-488:** SH1, AH1, T6, TE0, L4, LE0, SR1, RL1, PP0, DC1, DT0, C0, E2

**ISO Compliant**

The 8648A/B/C/D signal generators are manufactured in an ISO 9002 registered facility in concurrence with Agilent's commitment to quality.

### General

**Power Requirements:** 90 to 264 V, 48 to 440 Hz; 170 VA max.

**Operating Temperature:** 0° C to 50° C

**Leakage:** Conducted and radiated interference meets MIL-STD-461B RE02 and FTZ 1046. Typically < 1 μV.

### Key Literature

8648A/B/C/D Data Sheet, p/n 5965-3432E

Signal Generator Selection Guide, p/n 5965-3094E

8648A/B/C Brochure, p/n 5962-6191E

8648A Option 1EP Pager Encoder Datasheet, p/n 5964-4116E

### Ordering Information

**8648A** Synthesized Signal Generator

**8648B** Synthesized Signal Generator

**8648C** Synthesized Signal Generator

**8648D** Synthesized Signal Generator

**Opt 1EA** High Power (8648B/C/D only)

**Opt 1EP** Pager Encoder (8648A only)

**Opt 1E6** Pulse (8648B/C/D only)

**Opt 1E2** Modulation Generator

**Opt 1E5** High-Stability Timebase

**Opt 1CM** Rack Kit, p/n 08648-60001 (8648A/B/C/D)

**83301A** Memory Interface

8648A

8648B

8648C

8648D

5

ESG-A &  
ESG-AP  
Series

- Flexible architecture, upgrade paths for options
- Superior spectral purity on ESG-AP series
- 4 GHz electronic attenuator for reliability and repeatability
- Superior level accuracy
- Wideband FM and phase modulation
- Step sweep (frequency, power and list)
- Built-in function generator
- 3 year warranty



ESG-A series E4421B

### ESG-A and ESG-AP Series Analog Signal Generators



The Agilent ESG-A & AP series of analog RF signal generators offer excellent in-channel performance with superior quality and reliability, at an affordable price. The ESG-AP series provides all of the features of ESG-A, plus outstanding phase-noise performance. The ESG-A & AP series provide superb frequency and level control, and wide modulation capabilities. They are ideally suited to meet the demanding requirements of today's receiver test, component test and local oscillator applications.

For more information, visit the ESG web site:  
[www.agilent.com/find/esg](http://www.agilent.com/find/esg)

### Adaptable to Tomorrow's Requirements

The innovative design of the ESG-A & AP series provides a flexible architecture that can be tailored to meet the changing demands of evolving markets. These signal generators provide upgrade paths to add digital capabilities and options. With digital options, free firmware upgrades are available at: [www.agilent.com/find/firmware](http://www.agilent.com/find/firmware)

### Low Cost of Ownership

Low initial cost, three-year warranty and a two-year calibration cycle, are all features that help minimize the cost of ownership. The ESG-A and AP RF signal generators are designed for long-term dependability, maximizing production throughput and uptime.

### Excellent Level Accuracy

Superior level accuracy of  $\pm 0.5$  dB (above  $-127$  dBm,  $f_c < 2$  GHz) and  $\pm 0.9$  dB ( $f_c > 2$  GHz) provides unmatched performance and minimizes test uncertainty. This unprecedented performance ensures precise measurement of even the most sensitive analog receivers.

### High-Stability Timebase

The high stability timebase, Option 1E5, for the ESG-A series and standard on the ESG-AP series, provides increased frequency stability and accuracy, which results in reduced drift and phase noise. The high-stability timebase improves measurement repeatability and reliability.

### High-Performance Pulse Modulation, Option 1E6

The high performance pulse modulation, Option 1E6, for the ESG-A and AP series provides improved pulse rise and fall times, plus exceptional on/off ratios. Option 1E6 improves radar and pulse carrier measurements.

## Specifications

### Frequency

Range	ESG-A series	ESG-AP series (High Spectral Purity)
250 kHz – 1000 MHz	E4400B	E4423B
250 kHz – 2000 MHz	E4420B	E4424B
250 kHz – 3000 MHz	E4421B	E4425B
250 kHz – 4000 MHz	E4422B	E4426B

Resolution: 0.01 Hz

Frequency Accuracy:  $f_c \times$  timebase accuracy

### Switching Speed (typical)

	ESG-A	ESG-AP
Modulation on	<50 ms	<65 ms
Modulation off	<40 ms	<55 ms

Sweep Modes: Step: frequency and power, and arbitrary list

Dwell Time: 1 ms to 60 sec

Number of points: 2 to 401

### Internal Reference Oscillator

#### Timebase Stability

	ESG-A	Opt 1E5 ESG-A (Standard on ESG-AP)
Aging Rate	$< \pm 1$ ppm/yr.	$< \pm 0.1$ ppm/yr. or $< \pm 0.0005$ ppm/day after 45 days
Temperature (0° C to 55° C)	$< \pm 1$ ppm, typical	$< \pm 0.05$ ppm, typical
Line Voltage	$< \pm 0.1$ ppm (+5%, -10%), typical	$< \pm 0.002$ ppm, typical (+5%, -10%)

Time-base Accuracy:  $\pm$  aging rate  $\pm$  temperature effects  $\pm$  line voltage effects.

#### Timebase Reference Output:

Frequency: 10 MHz

Amplitude:  $>0.35$  V rms into 50  $\Omega$  load

#### External Reference Input:

Frequency: 1, 2, 5, 10 MHz,  $\pm$  typ. 10 ppm (typical 1 ppm, ESG-AP and Option 1E5 for ESG-A)

Amplitude:  $>0.15$  V rms

Input Impedance: 50 $\Omega$

## Output

### Power

Range	Standard	Option UNB
250 kHz to 1000 MHz	+13 to -136 dBm	+17 to -136 dBm
>1000 MHz to 3000 MHz	+10 to -136 dBm	+16 to -136 dBm
>3000 MHz to 4000 MHz	+7 to -136 dBm	+13 to -136 dBm

Resolution: 0.02 dB

### Level Accuracy (at 23° C $\pm$ 5° C)

Output Power/ Frequency Range	+7 to -120 dBm (+10 to -120 dBm, Opt UNB)	-120 to -127 dBm	<-127 dBm
250 kHz to 2 GHz	$\pm 0.5$ dB	$\pm 0.5$ dB	$\pm 1.5$ dB
>2000 MHz to 3 GHz	$\pm 0.9$ dB	$\pm 0.9$ dB	$\pm 2.5$ dB
>3000 MHz to 4 GHz	$\pm 0.9$ dB	$\pm 0.9$ dB ( $\pm 1.5$ dB, Opt UNB)	$\pm 2.5$ dB

Amplitude Switching Speed:  $< 30$  ms, typical

With Power Search Mode:  $< 300$  ms, typical

#### Reverse Power Protection:

250 kHz to 2000 MHz: 50 watts

>2000 MHz to 4000 MHz: 25 watts

Max. DC Voltage: 50 V

### SWR (typical)

Frequency Range	Standard	Option UNB
250 kHz to 2000 MHz	<1.4:1	<1.25:1
>2000 to 4000 MHz	<1.9:1	<1.35:1

Output Impedance: 50Ω

### Frequency Bands

Band	Frequency Range	N #
1	250 kHz to ≤249.999 MHz	1
2	>249.999 to ≤500 MHz	.5
3	>500 MHz to ≤1 GHz	1
4	>1 to ≤2 GHz	2
5	>2 to ≤4 GHz	4

Note: Refer to the N listed in Frequency Bands Table to compute specifications

### Spectral Purity

#### SSB Phase Noise (typical, at 20 kHz offset)

	ESG-A	ESG-AP (High Spectral Purity)
at 500 MHz	<-120 dBc/Hz	<-138 dBc/Hz
at 1000 MHz	<-116 dBc/Hz	<-134 dBc/Hz
at 2000 MHz	<-110 dBc/Hz	<-127 dBc/Hz
at 3000 MHz	<-104 dBc/Hz	<-124 dBc/Hz
at 4000 MHz	<-104 dBc/Hz	<-122 dBc/Hz

**Residual FM** (CW mode, 0.3–3 kHz, post detection BW, as specified by CCITT, rms)

#### ESG-A series:

Phase Noise Mode 1: <N x 2 Hz

Phase Noise Mode 2: <N x 4 Hz

#### ESG-AP series:

<N x 1 Hz (<N x .5 Hz, typical)

Note: Mode 1 optimizes phase noise at offsets <10 kHz and Mode 2 optimizes phase noise at offsets >10 kHz.

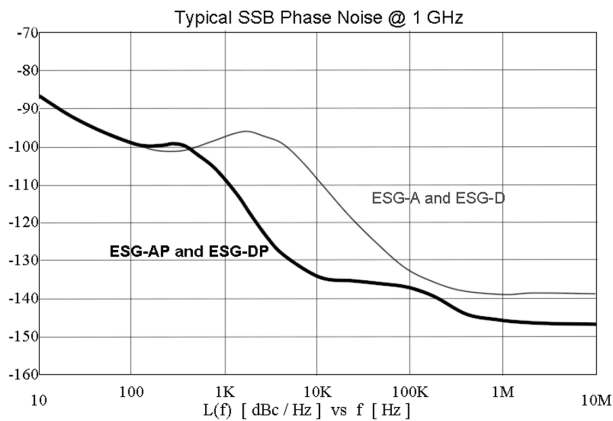

Figure 1: Typical SSB noise at 1 GHz (for additional phase noise plots, please refer to ESG family RF Signal Generators Technical Specifications literature, p/n 5965-3096E.)

### Frequency Modulation

#### Maximum Deviation:

ESG-A: N x 10 MHz

ESG-AP: N x 1 MHz

**Resolution:** 0.1% of deviation or 1 Hz, whichever is greater

**Deviation Accuracy** (1 kHz rate, dev. < N x 100 kHz):

< ± (3.5% of FM deviation + 20 Hz)

#### Modulation Frequency Response (deviation = 100 kHz)

Path	Rates	
	1 dB Bandwidth	3 dB Bandwidth, typical
FM1	20 Hz to 100 kHz	5 Hz to 10 MHz
FM2	20 Hz to 100 kHz	5 Hz to 1 MHz

**Distortion** For a deviation of N x 100 kHz, and 1 kHz rate, THD <1%.

### Phase Modulation Maximum Deviation

	ESG-A	ESG-AP
Normal BW	N x 90 radians	N x 10 radians
High BW	N x 2π radians	N x 1 radians

**Resolution:** 0.1% of set deviation

**Deviation Accuracy** (1 kHz rate): < ± (5% of deviation + 0.01 radians)

### Modulation Frequency Response ESG-A

Φ Mode	Max. Deviation	Rates (3 dB BW)	
		ΦM1	ΦM2
Normal BW	N x 90 rad	dc–100 kHz	dc–100 kHz
High BW	N x 2π rad N x π/2 rad	dc–1.5 MHz (typ.) dc–4 MHz (typ.)	dc–0.9 MHz (typ.) dc–1 MHz (typ.)

### ESG-AP

Φ Mode	Max. Deviation	Rates (3 dB BW)	
		ΦM1	ΦM2
Normal BW	N x 10 rad	dc–100 kHz	dc–100 kHz
High BW	N x 1 rad	dc–1 MHz (typ.)	dc–1 MHz (typ.)

**Distortion:** For a deviation of < N x 90 rad (< N x 10 rad for ESG-AP), and 1 kHz rate in normal BW mode, THD <1%.

**Amplitude Modulation fc > 500 kHz** (AM is typical above 3 GHz)

**Range** (envelope peak = max. specified power): 0 to 100%

**Resolution:** 0.1%

**Rates** (3 dB bandwidth): 10 Hz to 10 kHz

**Distortion** (1 kHz rate, THD): 30% AM: <1.5%, 90% AM: <4% (typical)

**Accuracy** (1 kHz rate): < ± (6% of modulation index setting + 1%)

(Example of accuracy: with 40% depth of modulation at 1 kHz rate, the accuracy will be ±2.4% + 1%)

### Pulse Modulation

**On/Off Ratio:** ≤3 GHz: > 80 dB; >3 GHz: >60 dB

**Rise/Fall Times:** 150 ns, typical

**Minimum Width** (typical): ALC On: 2μs; ALC Off: 0.4μs

**Pulse Repetition Frequency** (typical):

ALC On: 10 Hz–250 kHz

ALC Off: dc–1.0 MHz

**Level Accuracy** (relative to CW): ± 0.5 dB, typical

(With ALC on, repetition rates ≤10 kHz and pulse widths ≥5 μs)

#### Internal Pulse Generator:

**Squarewave Rates:** 0.1 Hz–50 kHz

#### Pulse:

**Period:** 16 μs to 30 sec

**Width:** 8 μs to 30 sec

**Resolution:** 4 μs

#### High Performance Pulse Modulation, Option 1E6

**On/Off Ratio:** ≤2 GHz: > 80 dB; >2 GHz: >70 dB

**Rise/Fall times:** <10 ns

### Internal Modulation Source

**Provides AM, FM, and ΦM Signals and LF Out**

**Waveforms:** sine, square, ramp, triangle, pulse, and noise

#### Rate Range:

**Sine:** 0.1 Hz–50 kHz

**Square, Ramp, Triangle:** 0.1 Hz–10 kHz

**Resolution:** 0.1 Hz

**Pulse only:** 4 μs

**Frequency Accuracy:** 0.005%, typical

**Swept Sine Mode** (Frequency, Phase Continuous)

**Operating Modes:** Triggered or Continuous Sweeps

**Frequency Range:** 0.1 Hz to 50 kHz

**Sweep Time:** 1 ms to 65 sec

**Resolution:** 1 ms

#### Dual Sinewave Mode

**Frequency Range:** 0.1 Hz to 50 kHz

**Amplitude Ratio:** 0 to 100%

**Amplitude Resolution:** 0.1%

ESG-A &  
ESG-AP  
Series

#### Low Frequency Out (Internal Modulation Source)

**Amplitude:** 0 to 3 V peak into 50  $\Omega$

**Output Impedance:** <1  $\Omega$

#### External Modulation Inputs

##### Modulation Types:

**Ext1:**  $\Phi$ M, FM, AM, and Burst Envelope

**Ext2:**  $\Phi$ M, FM, AM, and Pulse

**High/Low Indicator** (100 Hz to 10MHz BW, AC coupled inputs only):  
Activated when input level error exceeds 3% (nominal)

#### Simultaneous Modulation

All modulation types may be simultaneously enabled, except:  
FM with  $\Phi$ M; AM with Burst Envelope; Wideband AM with I/Q. AM,  
 $\Phi$ M and FM can sum simultaneous inputs from any two sources:  
EXT 1 and EXT 2, INT and EXT 1, INT and EXT 2. Any given source  
(INT, EXT 1 or EXT 2) may only be routed to one activated modulation type.

#### Remote Programming

**Interface:** GPIB (IEEE-488.2-1987) with Listen and Talk. RS-232.

**Control Languages:** SCPI version 1992.0, also compatible with 8656B and  
8657A/B/D/J mnemonics

**Functions Controlled:** All front-panel functions except power switch  
and knobs

#### General

**Power Requirements:** 90 to 254 V; 50, 60, or 400 Hz; 200 W maximum

**Operating Temperature Range:** 0° C to 55° C

**Leakage:** Conducted and radiated interference meets MIL-STD-461C  
CE02 Part 2 and CISPR 11

**Storage Registers:** Up to 800 storage registers, up to 10 sequences available

**Weight:** <12.7 kg (28 lb) net, <21 kg (46 lb) shipping

**Dimensions:** 133 mm H x 426 mm W x 432 mm D  
(5.25 in H x 16.8 in W x 17 in D)

#### Key Literature

ESG Family RF Signal Generators (brochure), p/n 5968-4313E

ESG Family RF Signal Generators Technical Specifications, p/n 5965-3096E

ESG Family RF Signal Generators Configuration Guide, p/n 5965-4973E

For additional literature references, see page 331.

For additional information, visit the ESG web site:

[www.agilent.com/find/esg](http://www.agilent.com/find/esg)

#### Ordering Information

##### ESG-A Series

**E4400B**

**E4420B**

**E4421B**

**E4422B**

##### ESG-AP Series

**E4423B**

**E4424B**

**E4425B**

**E4426B**

##### ESG-A Series Hardware Options

**Opt 1E5** Add high-stability timebase

##### ESG-A and ESG AP Series Hardware Options

**Opt 1E6** High performance pulse modulation

**Opt UNB** High power with mechanical attenuator

Documentation, support, and mechanical options available  
with any ESG model

##### Accessories

**Transit Case** p/n 9211-1296

##### Mechanical Options

**Opt 1CM** Rack mount kit

**Opt 1CN** Handle kit

**Opt 1CP** Rack mount and handle

**Opt 1EM** Moves connectors to rear panel

##### Operating and Service Documentation Options

**Opt 0B0** Deletes manual set

**Opt 0B1** Adds extra manual set

**Opt 0BV** Service documentation (component level)

**Opt 0BW** Service documentation (assembly level)

**Opt 0BX** Service doc. (assembly and component level)

##### Service Options

**Opt W32** 3 yrs. Customer return calibration service

**Opt W34** 3 yrs. Customer return compliant calibration  
(ANSI 540) service

**Opt W50** Adds additional warranty for total of 5 yrs.  
of customer return repair service

**Opt W52** 5 yrs. of customer return calibration service

**Opt W54** 3 yrs. Customer return compliant calibration  
(ANSI 540) service



- Firmware personality options for W-CDMA, cdma2000, and EDGE
- Superior spectral purity on ESG-DP Series
- 20 MHz RF bandwidth for I and Q
- Superior level accuracy
- Step sweep (frequency, power, and list)
- Wideband AM, FM, and phase modulation
- Real-time Baseband Generator (Option UN8)
- Built-in TDMA formats for DECT, GSM, NADC, PDC, PHS, and TETRA (with Option UN8)
- Internal Dual Arbitrary Waveform Generator (Option UND)
- Flexible creation of custom modulation (with Option UND)
- Internal Bit-Error-Rate Analyzer (Option UN7)
- 3 year warranty

## ESG-D and ESG-DP Series Digital and Analog Signal Generators



The Agilent ESG-D and ESG-DP series of RF signal generators provide a wide range of digital modulation capabilities, in addition to a comprehensive feature set and excellent analog performance – all at an affordable price. The ESG-DP series provides all the same features of the ESG-D series, plus outstanding phase-noise performance. The ESG-D and DP series provide excellent modulation accuracy and stability, as well as unprecedented level accuracy. These signal generators are ideally suited to meet the demanding requirements of today's digital receiver test, component test, and local oscillator applications.

For more information visit the ESG website :  
[www.agilent.com/find/esg](http://www.agilent.com/find/esg)

### Broadband I and Q Modulation

Use the analog I and Q inputs to generate complex modulation formats required for the development and testing of RF digital communications systems. A built-in quadrature modulator processes the I and Q input signals to provide superior modulation accuracy and stability over 10 MHz (1dB) baseband bandwidth.

### Excellent Level Accuracy

Superior level accuracy of  $\pm 0.5$  dB (above  $-127$  dBm,  $f_c < 2$  GHz) and  $\pm 0.9$  dB ( $f_c > 2$  GHz) provides unmatched specified performance and minimizes test uncertainty. Even with digital modulation turned on, level accuracy is better than  $\pm 1.1$  dB. This unprecedented performance ensures precise measurement of even the most sensitive analog or digital receivers.

### Hardware Options

#### Option UN8, Real-Time I/Q Baseband Generator

Option UN8 generates fully coded signals, which makes it ideally suited for testing receiver and base-station capabilities when measuring actual data is critical. This option simulates mobile or base-station transmissions of common digital communication standards.

Internally generate real-time signals for common standards to test receivers. Option UN8 includes DECT, GSM, NADC, PDC, PHS, and TETRA communication standards. Change modulation types, data, symbol rate, filter type, and filter factor to generate customized signals for component and system margin testing. Create custom signals by mapping I/Q values and building a unique FIR filter. Easily configure timeslots to simulate different types of traffic, control, or synchronization channels (or bursts). Generate mobile or base station transmissions with the internal burst capabilities. Also reduce the need for external equipment with comprehensive data generation capabilities. Option UN8 also includes limited Bluetooth capabilities.

#### Option UND, Internal Dual Arbitrary Waveform Generator

Option UND generates partially coded statistically correct signals, which make it ideally suited for component testing.

Playback virtually any mathematically generated waveform. Option UND provides an extremely flexible baseband generator for complex waveforms. I/Q files may be generated from application programs such as MATLAB. Download long or multiple waveforms (up to 1 Msample) to play or store in non-volatile RAM. The 14 bits of DAC resolution enhance dynamic range and noise performance. Optimized for I/Q generation, the dual arbitrary option simplifies setup. Pre-defined formats include NADC, PDC, PHS, GSM, DECT, TETRA, APC025, CDPD, PWT, and EDGE. Also test Bluetooth components and systems with standards-compliant signals.

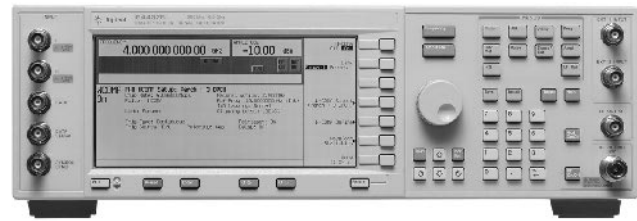

ESG-DP Series E4437B

#### Option UN7, Internal Bit-Error-Rate Analyzer

Perform bit-error-rate analysis for sensitivity and selectivity measurements. Option UN7 provides analysis capabilities to test any PN9 or PN15 bit sequence and indicates pass or fail conditions for user-specified test limits. Choose data rates up to 10 Mbps. The BER analyzer will automatically indicate when either data and/or clock signals are not valid. User defined resynchronization limit is available to reset counters and restart the measurement when data is lost.

### Firmware Options

Personalities are software programs that may be ordered already installed on a new ESG or may be downloaded from our web site: [www.agilent.com/find/firmware](http://www.agilent.com/find/firmware). The firmware may be activated by purchasing a license key. Once the license key is purchased, future firmware upgrades for that option are free.

Personality options cdmaOne (Option UN5), 3GPP W-CDMA (Option 100), and cdma2000 (Option 101) require the Arbitrary Waveform Generator (Option UND) hardware.

Personality options 3GPP W-CDMA (Option 200), cdma2000 (Option 201), and EDGE (Option 202) require the Real-time I/Q Baseband Generator (Option UN8) hardware.

#### Option UN5, Multichannel, Multicarrier cdmaOne Personality

Generate partially coded, multicarrier CDMA signals with multiple channels in each carrier for base-station and mobile tests, at system or component level. Tailor a test to specific requirements like the complementary cumulative distribution function (CCDF) by selecting predefined multicarrier CDMA configurations, or by explicitly defining the characteristics of each channel on each carrier. Testing with Walsh-coded channels accurately simulates the actual signal power a component experiences. View the power statistics of the IS-95 waveforms produced by the ESG-D & DP series compared to additive Gaussian white noise (AWGN).

#### Option 100, Multichannel, Multicarrier 3GPP W-CDMA Personality

Generate partially coded, multicarrier 3GPP W-CDMA signals with multiple channels. Users can generate both uplink and downlink signals that conform with version 3GPP 3.2 standards, which are suitable for component, subsystem, mobile, and base-station tests. Option 100 supports the new 3.84 Mcps chip rate, provides individual channel rates based on a 7.5 kpsps base for the downlink, and a 15 kpsps for an uplink. Downlink physical channels include PCCPCH, PSCH, SSCH, DPCH, CPICH, PICH, and OCNS.

#### Option 101, Multichannel, Multicarrier cdma2000 Personality

Generate partially coded, multichannel forward- and reverse-link signals, either 1X or 3X chip rate. Choose multicarrier or direct spreading type in forward link. HPSK spreading/demodulation type used in reverse link for IS95C radio configuration. Select from predefined channel configurations or use the table editor to fully configure a cdma2000 channel configuration according to user requirements. Forward-link channel types include pilot, paging, synchronization, fundamental code and supplemental channels. Reverse-link channel types include pilot, dedicated control channel, fundamental code and supplemental code channels. Each channel can be set to a separate code domain power level. Clip the peak-to-average power of signals before or after FIR filtering.

ESG-D &  
ESG-DP  
Series

**Option 200, Real-Time 3GPP W-CDMA Personality** NEW

Generate fully coded real-time W-CDMA uplink and downlink signals compliant with the latest revision of the 3GPP standards. By utilizing the real-time I/Q baseband generation of Option UN8 (Rev C or higher) and Option UN9, this firmware option provides fully coded reference measurement channels to perform BERT and baseband testing on mobile receiver and base-station designs. This complements the existing Option 100, which provides a partially coded multichannel multicarrier W-CDMA signal used for component test only. Option 200 gives the user the capability to generate custom physical, control, sync, and transport channels while supporting adjustments of the channel parameters. This flexibility combined with the ability to insert data bits at the transport or physical layer is ideal for different stages of testing.

**Option 201, Real-Time cdma2000 Personality**

Generate fully coded IS-2000 (SR1) signals for mobile receiver tests. Conduct frame or bit error tests and functional tests of the mobile unit's protocol handling. Option 201 is backward compatible with IS-95 systems using Radio Configurations 1 or 2. Fully coded channels include pilot, sync, paging, quick paging, fundamental, and supplemental traffic channels plus OCNS and QOF. Channels are easily configurable using the built-in table editor, with control over power level, FIR filter type, PN offset, Even Second delay, and others, depending upon channel type.

**Option 202, Real-Time EDGE Personality**

Generate continuous or framed signals. Produce fully coded signals using internally or externally generated data. Option 202 uses  $3\pi/8$ -rotating 8PSK, and "linearized" Gaussian Tx filter. Edit frame data fields and use custom filtering to keep pace with evolving EDGE definition. Synchronize two ESGs to combine EDGE (8PSK) and GSM (GMSK) timeslots. Upload externally defined burst shape waveforms.

**Other Options Available**

Other options are available to improve output power (Option UNB), to extend memory (Option UN9), and to vary timeslot power levels (Option UNA). There is a wide range of special options available that are not listed. If interested in any special options, please contact your Agilent sales representative.

**Specifications**

**Analog, Remote Programming, and General Specifications**

For analog, remote programming, and general specifications, please refer to the ESG-A & AP specifications located on page 202. ESG-A and ESG-D, and ESG-AP and DP have the same analog specifications except for:

- high performance pulse modulation, option 1E6, is not available on the ESG-D & DP
- frequency switching speed for Modulation on: ESG-D: <90 ms  
ESG-DP: <100 ms.

More specification differences, in addition to those listed above for the ESG-D and DP, are listed below.

**Frequency**

Frequency Range	ESG-D series	ESG-DP series (high spectral purity)
250 kHz – 1000 MHz	<b>E4430B</b>	<b>E4434B</b>
250 kHz – 2000 MHz	<b>E4431B</b>	<b>E4435B</b>
250 kHz – 3000 MHz	<b>E4432B</b>	<b>E4436B</b>
250 kHz – 4000 MHz	<b>E4433B</b>	<b>E4437B</b>

**Level Accuracy with Digital Modulation**

(After power search is executed; relative to CW level accuracy with ALC on; with burst off; if external I/Q is enabled:  $\sqrt{I^2 + Q^2} = 0.5$  V rms)

**Level Accuracy with ALC Off:  $\pm 0.3$  dB, typical**

(With ALC on; relative to CW; with PRBS-modulated data; if using I/Q inputs,  $\sqrt{I^2 + Q^2} = 0.5$  V rms nominal)

**$\pi/4$  DQPSK or QPSK Formats**

ESG-D	ESG-DP
$\pm 0.15$ dB	$\pm 0.20$ dB

(Relative to CW; with raised cosine or root-raised cosine filter and  $\alpha \geq 0.35$ ; with 10 kHz  $\leq$  symbol rate  $\leq 1$  MHz; at RF freq.  $\geq 25$  MHz; power  $\leq$  max. specified  $-3$  dBm or  $-6$  dBm with Option UNB.)

**Constant Amplitude Formats (FSK, GMSK, etc.)**

ESG-D	ESG-DP
No degradation in power level accuracy	$\pm 0.10$ dB

**I/Q Modulation**

**I & Q Inputs**

**Input Impedance:** 50  $\Omega$   
**Full Scale Input:**  $\sqrt{I^2 + Q^2} = 0.5$  V rms

**Adjustments/Impairments (nominal)**

DC Offset: (I and Q independently adjustable)  $\pm 100\%$   
I/Q Gain Ratio:  $\pm 4$  dB  
I/Q Quadrature:  $\pm 10^\circ$  (for  $f_c \leq 3.3$  GHz)

**DC Vector Accuracy**

(Relative to full scale, power  $\leq +7$  dBm ( $\leq +10$  dBm for Option UNB))

Frequency (GHz)	<0.6	0.6 to 2	2 to 3.7	$\leq 4$
<b>Static EVM (rms)</b>	<0.75%	<0.5%	<0.75%	<1%
<b>Magnitude Error (rms)</b>	<0.5%	<0.35%	<0.5%	<0.75%
<b>Phase Error (rms)</b>	<0.35 $^\circ$	<0.25 $^\circ$	<0.35 $^\circ$	<0.5 $^\circ$
<b>Origin Offset (dBc)</b>	<-46	<-46	<-40	<-40

**External Burst Envelope Control**

**Input Voltage**

RF On: 0 V  
RF Off: -1 V

**On/Off Ratio:**

$\leq 3$  GHz: > 75 dB  
> 3 GHz: > 60 dB

**Rise/Fall Time:** < 2  $\mu$ s with rectangular input, typical

**Minimum Burst Rate**

ALC On: 10 Hz, typical  
ALC Off: dc

**Input Impedance:** 50  $\Omega$ , nominal

**Coherent Carrier Out**

**Range:** 250 MHz to maximum carrier frequency

**Level:** 0 dBm  $\pm 5$  dB, typical

**Impedance:** 50  $\Omega$

**Option Specifications**

**Option UN8, Real-Time I/Q Baseband Generator**

The following formats are included with option UN8: NADC, PDC, PHS, TETRA, DECT, and GSM.

**Modulation Formats**

**PSK:** BPSK, QPSK, OQPSK,  $\pi/4$ DQPSK, 8PSK, 16PSK, D8PSK

**MSK:** User-defined phase offset  
QAM: 4, 16, 32, 64, 256

**FSK:** Selectable: 2, 4, 8, 16 level symmetric

**Custom I/Q:** Map of 16 unique values for I and Q

**Filters:** Nyquist, root Nyquist, Gaussian, Custom FIR, rectangular

**Filter Rate:**  $\alpha$ : 0 to 1;  $B_bT$ : 0.1 to 1

**Symbol Rate:** Adjustable up to 12.5 Msymbols/sec

**TDMA Data Structure**

Frames and timeslots may be configured as different types of traffic or control channels. The data field of a timeslot can accept user file, PRBS (PN9 or PN15) or external data with the appropriate clock.

**Internally Generated Data**

Pseudo-Random Patterns: Continuous PN9, PN11, PN15, PN20 or PN23

Repeating Sequence: Any 4-bit sequence

**Downloadable Data**

**Direct-pattern RAM (PRAM)**

MaxSize: 1 Mbytes (std.); 8 Mbytes (Option UN9)

**User File max. size:** 128 kbytes

**Externally Generated Data**

**Inputs:** Data, bit/symbol clocks (accepts rates  $\pm 5\%$  of specified data rate)

**Reference Frequency**

Internal or external: 1, 2, 5, 10 MHz reference.

Data clock can be locked to an external 13 MHz (GSM) reference

**Frame Trigger Delay Control**

Range: 0 to 65,535 bits

Resolution: 1 bit

**Internal Burst Shape Control (varies with standards and bit rates)**

Rise/Fall Time Range: Up to 30 bits

Rise/Fall Delay Range: 0 to 63.5 bits

**I/Q Outputs**

EVM (NADC, PDC, PHS, TETRA): 1% rms

Global Phase Error (GSM): 0.75 $^\circ$  rms

Deviation Accuracy (DECT): 1 kHz rms

**Option UND, Dual Internal Arbitrary Waveform Generator**

The following predefined formats are included with option UND:  
NADC, PDC, PHS, GSM, DECT, TETRA, APC025, CDPD, PWT, EDGE  
**Channels:** 2

**Resolution:** 14 bits (1/16384)

**Waveform Memory**

**Playback:** 1 Msample/channel

**Storage (non-volatile RAM):** 1 Msample/channel

**Waveform Segments**

**Length:** 16 samples to 1 Msample

**Number of Segments:** 1 to 128

**Waveform Sequences**

**Sequencing:** Continuously repeating

**Number of Sequences:** 1 to 128

**Sample Rate:** 1 Hz to 40 MHz

**Output Reconstruction Filters**

**Type:** Elliptic

**Fcutoff (nominal, 3 dB):** 250 kHz, 2.5 MHz, 8 MHz and through

**Baseband Spectral Purity**

(typical, full scale sinewave, >20 x oversampling)

**Harmonic distortion**

≤100 kHz: ≤-80 dBc

100 kHz to 2 MHz: <-65 dBc

**Non-Harmonic spurious:** <-80 dBc

**Phase Noise:** <-120 dBc/Hz

(baseband output of 1 MHz sinewave at 20 kHz offset)

**IM Performance:** <-69 dB

(two sinewaves at 950 kHz and 1050 kHz at baseband, full scale)

**Option UN7, Bit-Error-Rate Analyzer**

**Clock Rate:** 100 Hz to 10 MHz

**Supported Data Patterns:** PN9, PN15

**Resolution:** 10 digits (6 digits for BER (exponential display))

**Minimum Synchronization Length**

**2 Mbps Mode:** 9 bits (PN9), 15 bits (PN15)

**10 Mbps Mode:** 43 bits (PN9), 48 bits (PN15)

**Bit Sequence Length:** 100 bits to 4.294 Gbits after synchronization

**Features**

	2 Mbps mode	10 Mbps mode
Bit count	X	X
Error-bit-count	X	
Bit-Error-Rate	X	
Pass/fail indication	X	X
Valid data and clock detection	X	X
Automatic re-synchronization	X	
Special pattern ignore	X	

**Option UN5, Multichannel, Multicarrier cdmaOne Personality**

**Chip (symbol) Rate:** 1.2288 MHz (default) Adjustable to 1 Hz to 10 MHz with 4x oversampling

**Modulation**

QPSK (forward): With Walsh and short code spreading

Offset QPSK (reverse): With short code spreading of random data

**Predefined Channel Configurations** (power levels per IS-97-A)

**Pilot Channel:** Incl. IS-95 modified filter, with equalizer

**9 Channel:** Incl. pilot, paging, sync, 6 traffic and IS-95 modified filter, with equalizer

**32 Channel:** Incl. pilot, paging, sync, 29 traffic and IS-95 modified filter, with equalizer

**64 Channel:** Incl. pilot, 7 paging, sync, 55 traffic and IS-95 modified filter, with equalizer

**Reverse Channel:** Incl. IS-95 filter

**Rho:** 0.9996

(≤4dBm, IS-95 filter, ≤2 GHz, typical)

**Option 100, Multichannel 3GPP W-CDMA Personality**

**Chip Rates:** 3.84 Mchips/sec ± 10 %

**Downlink**

**Modulation:** QPSK

**Predefined channel configurations** (partially coded)

1 DPCH

3 DPCH

PCCPCH + SCH

PCCPCH + SCH + 1 DPCH

PCCPCH + SCH + 3 DPCH

**Test Model 1:** with 16, 32, or 64 DPCH

**Test Model 2**

**Test Model 3:** with 16 or 32 DPCH

**Test Model 4**

**Channel Types**

(downlink) PICH, OCNS, PCCPCH, PSCH, SSCH, CPICH, DPCH

(uplink) DPCCCH, DPDCH

**Multicarrier**

**Number of carriers:** Up to 4 (user defined, individually configurable)

**Frequency offset** (per carrier): Up to ± 7.5 MHz

**Offset resolution:** <1Hz

**Uplink**

**Modulation:** OQPSK (HPSK)

**Predefined channel configurations** (partially coded)

1 DPCCCH

15 kspcs, spread code 0

DPCCCH + 1 DPDCH

960 kspcs, spread code 1

DPCCCH + 2 DPDCH

960 kspcs, spread code 1

DPCCCH + 3 DPDCH

960 kspcs, spread code 2

DPCCCH + 4 DPDCH

960 kspcs, spread code 2

DPCCCH + 5 DPDCH

960 kspcs, spread code 3

**Option 200, Real-time W-CDMA Personality****Downlink Specifications****Channel Types Generated**

Primary Synchronization (PSCH), Secondary Synchronization (SSCH), Primary Common Control (P-CCPCH), Common Pilot (CPICH), Dedicated Physical (DPCH), Page Indication (PICH), Acquisition Indication (AICH), Physical Downlink Shared (PDSCH)

**Channel Configurations****PSCH**

Power: -40 to 0 dB

**SSCH**

Power: -40 to 0 dB

Secondary Scramble Code Group: 0 to 63

**P-CCPCH**

Power: -40 to 0 dB OVSF: 0 to 511

Data: PN9, FIX4, User File, Transport Channel

Transport Channel: BCH Coding

System Frame Number (SFN): Incrementing

**CPICH**

Power: -40 to 0 dB

**DPCH**

Reference Measurement Setup: 12.2, 64, 144, 384 kbps

Data: PN9, PN15 (12.2 and 64 kbps only), 4-bit repeating pattern, User File

**Physical Channel:**

Power, OVSF, Slot Format, TPC, TFIC

Symbol Rate: 7.5-960 kspcs

TDPCCH Offset: 0 to 149

Secondary Scramble Code Offset: 0 to 15

Data: PN9, PN15, 4-bit repeating pattern, User File,

Transport Channel

**Transport Channel (DCH) Control:**

(Up to 6 DCH's for each DPCH)

Block Size, Transport Time Interval (TTI), Rate Matching,

CRC Size, Transport Channel Number

Data: PN9, PN15, FIX4, User File

Coding: None, Convolutional 1/2, Convolutional 1/3, Turbo

**PICH**

Power: -40 to 0 dB

OVSF: 0 to 511

**Uplink Specifications**

See ESG Technical Specifications, p/n 5965-3096E and Configuration Guide, p/n 5965-4973E for details.

**Option 101, Multichannel cdma2000 Personality****Spreading Rate:** SR1,SR3**Multicarrier:** Up to 12 (user defined, individually configured)**Frequency Offset** (per carrier): -7.5 MHz to +7.5 MHz**Power Offset:** 0 dB to -40 dB**Forward Link****Spreading Type:** Direct spread (DS), multicarrier**User-defined cdma2000** (Channel types)

(partially coded) Pilot, paging (SR1 only), sync, fundamental, and supplemental

**Radio Configuration:****SR1:** 1 to 5**SR3:** 6 to 9**Data Rate:** 1.2 kbps to 1036.8 kbps, depends on the selected radio configuration**Walsh Code:** Pilot and sync have fixed codes, Walsh 0 and 32.**Channel Power:** 0 to -40 dB**PN Offsets:** 0 to 511**Data Pattern:** 00-FF(HEX) or random**Reverse Link****Spreading Type:** Direct spread only**User-defined cdma2000** (Channel types)

(partially coded) Pilot, dedicated control channel, fundamental, and supplemental

**Radio Configuration:** 1 to 6**Data Rate:** 1.2 kbps to 1036.8 kbps, depends on radio config.**Channel Power:** 0 to -40 dB**Data Pattern:** 00-FF(HEX) or random**Option 201, Real-time cdma2000 Personality****Channel Types Generated** Up to four channels of any of the following:

Pilot, Paging, Quick Paging, Sync, F-Fundamental, F-Supplemental, OCNS

**Global controls across all channels****Channel Power:** 0 to -40 dB**Filters:** IS95, IS95 w/eq, IS95 mod, IS95 mod w/eq, Root Nyquist, Nyquist, Gaussian, user-defined FIR, Rectangle, APCO 25 C4FM**Spread Rate:** 1**PN Offset:** 0 to 511**Chip Rate:** 50 Hz to 1.3 MHz**Even Second Delay:** 0.5 to 128 chips**I/Q Voltage Scale:** 0 to -40 dB**Code Domain Power:** Equal powers or scale to 0 dB**Pilot Channel****Walsh:** 0 (non-adjustable)**Sync Channel****Walsh:** 0 to 63**Data:** Free editing of the following: SID, NID, F-synch type, Sys\_Time, PRAT, LTM\_Off, Msg\_Type, P\_REV, MIN\_P\_REV, LP\_SEC, DAYLT, CDMA Freq, ext CDMA freq, and Reserved**Paging channel****Walsh:** 0 to 63**Data:** Default paging message or Userfile**Long Code Mask:** 0-3FFFFFFF (HEX)**Rate:** 4.8 or 9.6 kbps**Quick paging channel****Power:** 0 to -40 dB**Walsh:** 0 to 127**Data rate:** 2.4 kbps to 4.8 kbps**Config. change:** 0 to 3**Paging indicator:** -1 to 383**Fundamental channel****Radio Config.:** 1 to 5**Walsh:** 0 to 63**Data Rate:** 1.2 to 14.4 kbps, depending on radio configuration data PN9, PN15, userfile, external serial data, or predefined bit patterns**Long Code Mask:** 0-3FFFFFFF (HEX)**Power Control:** N up/down, "N" may be set from 1 to 80**Power Puncture:** On/Off**Frame Offset:** 0 to 15**Frame Length:** 20ms (non-adjustable)**QOF:** 0 to 3**Supplemental Channel** (Same channel configuration as Fundamental, except)**Radio Config.:** 3 to 5**Walsh:** 0 to 63, depending on RC and Data Rate**Data Rate:** 19.2 to 307.2 kbps, depending on radio configuration**Turbo Coding:** May be selected for data rates from 28.8 to 153.6 kbps**OCNS Channel****Walsh:** 0 to 63**Option 202, Real-time EDGE Personality****Modulation:**  $3\pi/8$ -rotating 8PSK (per EDGE specifications)  
User-selectable (see Modulation under Option UN8)**Filter:** "Linearized" Gaussian (per EDGE specifications)

User-selectable (see Filter under Option UN8)

**Symbol rate:** User-adjustable (see Symbol rate under Option UN8)  
270.833 kHz (default)**Burst Shape:** Defaults to EDGE standard power vs. time mask with user definable burst shape. Alternatively, upload externally defined burst shape waveforms.**Data structure:** Time slots may be configured as normal or custom. The data field of a time slot can accept a user file, PRBS (PN9 or PN15), a fixed sequence or external data. All other fields in a timeslot are editable. Conforms to 8.3.0 Release 99.**Key Literature**

ESG Family RF Signal Generators (brochure), p/n 5968-4313E

ESG Family RF Signal Generators Technical Specifications,

p/n 5965-3096E

ESG Family RF Signal Generators Configuration Guide, p/n 5965-4973E

For additional literature references, see page 331.

For additional information, visit our website: [www.agilent.com/find/esg](http://www.agilent.com/find/esg)**Ordering Information****ESG-D Series****E4430B****E4431B****E4432B****E4433B****ESG-DP Series****E4434B****E4435B****E4436B****E4437B****ESG-D Series Options****Opt 1E5** Add high-stability timebase**ESG-D and ESG DP Series Options****Opt UNA** Alternate time slot level control  
(for Option UN8)**Opt UNB** High power with mechanical attenuator**Hardware Options****Opt UND** Internal dual arbitrary waveform generator**Opt UN7** Internal Bit-Error-Rate Analyzer**Opt UN8** Real-time I/Q baseband generator**Opt UN9** Add 7M RAM to Opt UN8**Firmware Options****Opt UN5** Multicarrier, multichannel cdmaOne  
Personality for Option UND**Opt 100** Multicarrier, multichannel W-CDMA  
Personality for Option UND**Opt 101** Multicarrier, multichannel W-CDMA  
Personality for Option UND**Opt 200** Real-time W-CDMA Personality for  
Option UN8/UN9**Opt 201** Real-time cdma2000 Personality for Option UN8**Opt 202** Real-time EDGE Personality for Option UN8

Documentation, support, &amp; mechanical options available with any ESG model. Please see ESG-A &amp; AP Ordering Information on page 204



- Frequency ranges of 1 GHz, 2 GHz, 3 GHz, 4.2 GHz, or 6 GHz
- Lowest overall noise and spurious
- AM, FM, and pulse modulation
- Lowest specified leakage (optional)
- Internal modulation source for complex waveforms
- Onsite repair and calibration



8643A, 8644B, 8665B

8643A  
8644B  
8664A  
8665A  
8665B

These signal generators offer RF designers and manufacturers a selection of frequency range and high performance. The 8643A, 8644B, and 8664A are for traditional out-of-channel receiver test applications. The 8665A/B are for high-performance applications up to 6 GHz, particularly radar, telemetry and spurious testing of UHF receivers. All signal generators within this performance family have options that allow them to be configured to meet specific application needs.

### 8643A 1 GHz/2 GHz Signal Generator



Agilent has optimized the 8643A's configuration with the performance necessary for out-of-channel receiver tests while maintaining a low price. Options have been limited on the 8643A, but many performance/feature capabilities have been included as standard.

### Standard Electronic Attenuator and Advanced Modulation Source

Reliability is enhanced by the use of an electronic attenuator on the 1 GHz version. Instead of using mechanical relays for setting levels, the 8643A uses solid-state components accurate to within  $\pm 1.0$  dB. The 8643A comes standard with an advanced internal modulation synthesizer that provides coverage to 400 kHz and two-tone capability with the selection of sine, square, sawtooth, and white Gaussian noise waveforms.

### 8644B 1 GHz/2 GHz High-Performance Signal Generator



The 8644B represents the highest overall performance in Agilent's line of 1 GHz and 2 GHz signal generators. The 8644B builds on the 8643A's performance by lowering SSB phase noise ( $-136$  dBc/Hz versus  $-130$  dBc/Hz) and lowering spurious ( $-105$  dBc versus  $-100$  dBc). The 8644B can be used either for specific tests that require the lowest SSB phase noise or for applications with diversified performance requirements.

### 8664A 3 GHz, 8665A 4.2 GHz and 8665B 6 GHz High-Performance Signal Generators



These three signal generators offer identical performance except for frequency coverage and price. Your application will dictate which instrument is required. The 8664A and 8665A/B are suited for out-of-channel receiver measurements through the use of Option 004 (low-noise enhancement) and for such applications as radar testing through the use of Option 008 (pulse modulation).

### Wideband FM and Optional Pulse Modulation

FM rates of up to 2 MHz and deviations to 20 MHz peak are suitable for many applications such as higher-rate digital communications. An optional pulse modulator with on/off ratio of  $>80$  dB and rise/fall times of  $<5$  ns is available. Pulse width and delay can be internally adjusted between 50 ns and 999 ms, eliminating the need for an external pulse generator.

5

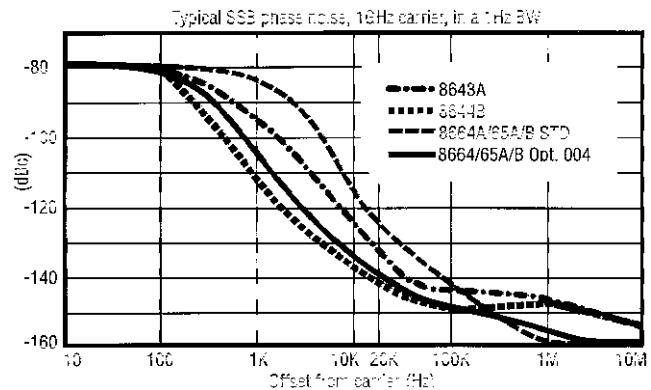

Typical SSB Phase Noise, at 1 GHz Carrier, in a 1 Hz BW

### Specifications

	8643A	8644B	8664A; 8665A/B
<b>Frequency Range</b>	0.252 to 1030 MHz 0.252 to 2060 MHz (Option 002)	0.252 to 1030 MHz 0.252 to 2060 MHz (Option 002)	0.1 to 3000 MHz (8664A) 0.1 to 4200 MHz (8665A) 0.1 to 6000 MHz (8665B)
<b>Resolution</b>	0.01 Hz	0.01 Hz	0.01 Hz
<b>Accuracy</b>	Timebase stability $\times f_c$	Timebase stability $\times f_c$	Timebase stability $\times f_c$
<b>Switching speed (typical)</b>	$< 90$ ms; $< 200$ ms with FM on	$< 350$ ms	$< 100$ ms (Option 004)

### Internal Reference Oscillator

Output: 10 MHz,  $> 0.15 V_{rms}$  into  $50 \Omega$ ; (Option 001)  $> 1 V_{rms}$  into  $50 \Omega$

### Timebase Stability

	Standard Timebase	High Stability (Opt. 001)
<b>Aging Rate:</b>	$1.5 \times 10^{-8}$ /day	$3 \times 10^{-10}$ /day
<b>Temperature Effects:</b>	$7 \times 10^{-10}$	$6 \times 10^{-10}$
<b>Line Voltage Effects:</b>	$2 \times 10^{-10}$	$1 \times 10^{-10}$

### Specifications, cont.





	8643A	8644B	8664A; 8665A/B
<b>Spectral Purity</b>			
SSB phase noise @ 1 GHz (20 kHz offset)	-130 dBc/Hz	-136 dBc/Hz	-117 dBc/Hz; -134 dBc/Hz (Option 004)
Nonharmonics: (>10 kHz offset)	< -100 dBc, 0.252 to 1030 MHz < -94 dBc, 1030 to 2060 MHz	< -105 dBc, 0.252 to 1030 MHz < -100 dBc, 1030 to 2060 MHz < -25 dBc, output ≤ +10 dBm	< -100 dBc, 187.5 to 2060 MHz < -90 dBc, 2060 to 6000 <sup>1</sup> MHz, 0.1 to 187.5 MHz < -30 dBc, output ≤ +10 dBm
Harmonics < -30 dBc, output ≤ +8 dBm (with Option)			
Subharmonics	None, 0.252 to 515 MHz < -52 dBc, 515 to 1030 MHz < -40 dBc, 1030 to 2060 MHz < 2 Hz rms	None, 0.252 to 515 MHz < -52 dBc, 515 to 1030 MHz < -40 dBc, 1030 to 2060 MHz < 1 Hz rms	< -75 dBc, 0.1 to 1500 MHz < -40 dBc, 1500 to 3000 MHz < -50 dBc, 3000 to 6000 <sup>1</sup> MHz < 7.5 Hz rms; < 1.2 Hz rms (Option 004)
Residual FM @ 1 GHz: 0.3 to 3 kHz post det. BW			
<b>Output Level</b>			
Range	+ 13 to -137 dBm	+ 16 to -137 dBm, + 13 dBm (Option 002, 005)	+ 13 to -139.9 dBm, + 9 dBm (Option 008)
Resolution	0.1 dB	0.1 dB	0.1 dB
Absolute accuracy	± 1 dB, output ≥ -127 dBm	± 1 dB, output ≥ -127 dBm	± 1 dB, output ≥ -119.9 dBm, 1 to 1000 MHz ± 1.5 dB, output ≥ -119.9 dBm, 1000 to 3000 MHz ± 2 dB, output ≥ -119.9 dBm, > 3000 <sup>1</sup> MHz, < 1 MHz
Reverse power protection	50 W	50 W	25 W <sup>2</sup> , 0.1 to 2060 MHz; 1 W, > 2060 <sup>1</sup> MHz
<b>Amplitude Modulation</b>			
Depth: (@ ≤ + 7 dBm)	0 to 100%	0 to 100%	0 to 100%
Resolution	0.1%	0.1%	0.1%
Bandwidth (3 dB) ≤ + 7 dBm	dc to 100 kHz, 128 MHz < f <sub>c</sub> < 1030 MHz	dc to 100 kHz, 128 MHz < f <sub>c</sub> < 1030 MHz	dc to > 10 kHz, > 10 MHz
Accuracy: 1 kHz rate	± (7% of setting + 1%) up to 80% depth	± (7% of setting + 1%) up to 80% depth	± (6% of setting + 1%) up to 90% depth
Distortion: 30% depth, 1 kHz rate	< 2%; < 4% (Option 002)	< 2%; < 4% (Option 002)	< 4%
<b>Frequency Modulation</b>			
Maximum peak deviation (Deviation halves per lower octave)	2 MHz, 1030 to 2060 MHz; 1 MHz, 515 to 1030 MHz	20 MHz/200 kHz <sup>3</sup> , > 1030 MHz; 10 MHz/100 kHz <sup>3</sup> , > 515 MHz	20 MHz, 3000 to 6000 <sup>1</sup> MHz; 10 MHz, 1500 to 3000 MHz
Resolution	2.5% of setting	2.5% of setting	2.5% of setting
Bandwidth (3 dB)	dc to 100 kHz	dc to 100 kHz	dc to 800 kHz
Carrier accuracy in FM	± 0.5% of setting	± 0.5% of setting	± 0.6% of setting
Indicator accuracy	< 5%, < 30 kHz rates; < 10%, < 100 kHz rates	< 5%, < 30 kHz rates; < 10%, < 100 kHz rates	± 9%, < 20 kHz rates
Distortion	< 5%, 20 Hz to 100 kHz rates	< 5%, 20 Hz to 100 kHz rates	< 1%, 20 Hz to 20 kHz rates
<b>Pulse Modulation</b>			<b>Option 008</b>
On/off ratio	> 50 dB; > 80 dB, > 1030 MHz	> 35 dB; > 80 dB, > 1030 MHz	> 80 dB
Rise/fall time, 10 to 90%	< 100 ns	< 100 ns	< 8 ns
Repetition rate	dc to 1 MHz	dc to 1 MHz	dc to 10 MHz
Internal width/delay	N/A	N/A	Variable, 50 ns to 1 s
<b>Internal Modulation Source</b>			
Waveforms and rates	Sine; white Gaussian noise (0.1 Hz to 400 kHz); Triangle, sawtooth, square (0.1 Hz to 50 kHz)		
Frequency accuracy	Same as timebase		
Output level (into 600 Ω)	1 V pk, 2 V pk for 8643A and 8644B		
Output resolution	2 mV pk		
<b>Frequency Sweep</b>			
Digital sweep	Digitally stepped sweep over entire frequency range. Linear/log selection. 0.5 to 1000 s sweeps.		
Markers/Z-axis output	3 markers available/Z-axis output nominally + 5 V/X-axis output nominally 0 to 10 V		
Phase continuous sweep	40 MHz of span available at maximum carrier frequency. 20 ms to 10 s sweep times.		
<b>Remote Programming</b>			
Interface	GPIB (IEEE 488.2-1987)		
Control language	Hewlett-Packard Systems Language (HP-SL). All functions controlled except power.		
IEEE-488 functions	SH1, AH1, T6, TE0, L4, LE0, SR1, RL1, PPO, DC1, DT0, C0, E2		
<b>General</b>			
Power requirements	± 10% of 100 V, 120 V, 220 V, or 240 V; 48 to 440 Hz; 500 VA (except 8643A/44B: 400 VA)		
Operation temperature	0° C to 55° C		
Leakage	Conducted and radiated interference meets MIL-STD-461B RE0 <None> 2 and FTZ 1046		
Calibration interval	Recommended 3 years (MTBC)		
Weight	8643A: 23 kg (50 lb). 8644B: 30 kg (67 lb). 8664A/65A/B: 35 kg (78 lb).		
Size	177 mm H x 426 mm W x 624 mm D (7 in x 16.8 in x 24.6 in). Option 010 adds 35 mm (1.4 in) to D.		

<sup>1</sup> 3000 MHz for 8664A, 4200 MHz for 8665A, 6000 MHz for 8665B

<sup>2</sup> N/A to 8665B

<sup>3</sup> Low-noise mode

### Ordering Information

	8643A	8644B	8664A	8665A	8665B
<b>Options</b>					
<b>001</b> High-Stability Timebase					
<b>002</b> 2 GHz Doubled Output					
<b>004</b> Low-Noise Option					
<b>005</b> Electronic Attenuator (N/A with Option 002)					
<b>008</b> Pulse Modulation					
<b>009</b> Specified VOR/ILS <sup>2</sup>					
<b>011</b> 2 GHz Internal Frequency Counter					
<b>Service Kit</b>	(08645-61116)	(08645-61116)	(08665-61116)	(08665-61116)	(08665-61116)
<b>003</b> Rear-Panel Input/Output					
<b>010</b> Reduced-Leakage Configuration					
<b>W30</b> Add 3 Years to Return Warranty					
<b>907</b> Front-Handle Kit (5062-3990)					
<b>908</b> Rack Flange Kit (5062-3978)					
<b>909</b> Combined Front/Rack Flange Kit (5061-9684)					

<sup>1</sup> See Specifications

<sup>2</sup> Not compatible with Options 002 or 005

- 10 kHz to 1280 MHz frequency range
- <-147 dBc/Hz SSB phase noise at 10 kHz offset
- 0.1 Hz frequency resolution



8662A

- 100 kHz to 2560 MHz frequency range
- AM/FM/ΦM/pulse in one generator
- Internal variable modulation oscillator



8663A

8662A  
8663A

### 8662A/8663A Synthesized Signal Generators ← GPIB

Spectral purity is the key contribution of both the Agilent 8662A and 8663A, making them ideal for many radar, satellite communication, and phase noise measurement applications. Typical absolute phase noise performance of these generators at a 1 kHz offset is as low as -135 dBc/Hz, depending on the band of operation.

The frequency range of the 8662A is 10 kHz to 1280 MHz. It offers versatile AM/FM, using either internal 400 Hz and 1 kHz rates or externally applied modulating signals which can be either ac- or dc-coupled. It also has simultaneous modulation capability.

The 8663A and 8662A provide the U.S. Air Force MATE (Modular Automatic Test Equipment) capability, via Option 700. This option is an external translator that allows the signal generator to be controlled by the MATE language CIIL (Control Interface Intermediate Language).

### 8662A Specifications

#### Frequency

**Range:** 10 kHz to 1280 MHz (1279.999998 MHz)

**Resolution:** 0.1 Hz (0.2 Hz above 640 MHz)

**Accuracy and Stability:** Same as reference oscillator

**Internal Reference Oscillator:** 10 MHz quartz oscillator. Aging rate < 5 x 10<sup>-10</sup>/day after 10-day warmup (typically 24 hrs. in normal operating environment).

#### Spectral Purity

**Front-Panel Absolute SSB Phase Noise (dBc/Hz):**

Frequency range (MHz)	0.01 to 119.9 <sup>1</sup>		120 to 159.9 <sup>2</sup>		160 to 319.9 <sup>2</sup>	
	Spec	Typ	Spec	Typ	Spec	Typ
1 Hz	-68	-78	-66	-76	-60	-70
10 Hz	-98	-108	-96	-106	-90	-100
100 Hz	-116	-126	-115	-125	-109	-119
1 kHz	-126	-132	-129	-135	-124	-130
3 kHz	-126	-135	-129	-138	-124	-133
5 kHz	-128	-138	-131	-141	-126	-136
10 kHz	-132	-138	-142	-148	-136	-142
100 kHz	-132	-139	-142	-148	-136	-142

Frequency range (MHz)	320 to 639.9 <sup>2</sup>		640 to 1279.9 <sup>3</sup>		1280 to 2559.9 <sup>4</sup>	
	Spec	Typ	Spec	Typ	Spec	Typ
1 Hz	-54	-64	-48	-58	-42	-52
10 Hz	-84	-94	-78	-88	-72	-82
100 Hz	-103	-114	-97	-108	-92	-102
1 kHz	-118	-125	-112	-119	-106	-113
3 kHz	-118	-127	-112	-121	-106	-115
5 kHz	-120	-130	-114	-124	-108	-118
10 kHz	-131	-136	-124	-130	-118	-124
100 kHz	-131	-136	-124	-130	-118	-124

### Residual SSB Phase Noise (dBc/Hz):

Frequency range (MHz)	0.01 to 119.9 <sup>1</sup>		120 to 159.9 <sup>2</sup>		160 to 319.9 <sup>2</sup>	
	Spec	Typ	Spec	Typ	Spec	Typ
10 Hz	-108	-114	-112	-119	-106	-113
100 Hz	-121	-126	-122	-129	-118	-124
1 kHz	-128	-133	-131	-138	-127	-134
3 kHz	-128	-136	-131	-139	-127	-135
5 kHz	-129	-138	-133	-141	-129	-136
10 kHz	-132	-137	-142	-147	-136	-142
100 kHz	-132	-137	-142	-147	-136	-142

Frequency range (MHz)	320 to 639.9 <sup>2</sup>		640 to 1279.9 <sup>3</sup>		1.28 to 2559.9 <sup>4</sup>	
	Spec	Typ	Spec	Typ	Spec	Typ
10 Hz	-100	-107	-93	-101	-88	-95
100 Hz	-112	-119	-105	-112	-100	-106
1 kHz	-121	-128	-115	-122	-109	-116
3 kHz	-121	-129	-115	-123	-109	-117
5 kHz	-123	-130	-117	-124	-111	-118
10 kHz	-131	-136	-124	-130	-118	-124
100 kHz	-131	-136	-124	-130	-118	-124

<sup>1</sup>8663A band begins at 0.1 MHz; specifications extend up to and including 119.999999 MHz.

<sup>2</sup>Specifications extend up to and including 0.1 Hz less than the starting frequency of the next band.

<sup>3</sup>Specifications extend up to and including 1279.999998 MHz.

<sup>4</sup>This band available on 8663A only; specifications extend up to and including 2559.999996 MHz.

### Option 003 Specified SSB Phase Noise for Rear-Panel 640 MHz Output:

	Spec	Typ
1 Hz	-54	-64
10 Hz	-84	-94
100 Hz	-104	-114
1 kHz	-121	-126
3 kHz	-121	-127
5 kHz	-129	-138
10 kHz	-145	-149
100 kHz	-157	-159

### SSB Broadband Noise Floor in 1 Hz BW at 3 MHz Offset From Carrier:

<-146 dBc for fc between 120 and 640 MHz at output levels above +10 dBm.

### Spurious Signals:

	Frequency Range (MHz)				
	0.01 to 120	120 to 160	160 to 320	320 to 640	640 to 1280
Spurious non-harmonically related <sup>1,2</sup>	-90 dBc	-100 dBc	-96 dBc	-90 dBc	-84 dBc
Sub-harmonically related ( $\frac{1}{2}, \frac{3f}{2}$ , etc.)	none	none	none	none	-75 <sup>3</sup> dBc
Power-line (60 Hz) related or microphonically generated (within 300 Hz) <sup>4</sup>	-90 dBc	-85 dBc	-80 dBc	-75 dBc	-70 dBc
Harmonics	< -30 dBc				

### Output

**Level Range:** +13 to -139.9 dBm (1V to 0.023  $\mu$ V<sub>rms</sub> into 50  $\Omega$ )

**Resolution:** 0.1 dB

**Absolute Level Accuracy:** (+15° to +45° C):  $\pm 1$  dB between +13 and -120 dBm;  $\pm 3$  dB between -120 and -130 dBm

**SWR:** Typically from 1.5 to 1.8, depending on output level and frequency

**Reverse Power Protection:** Typically up to 30 W or  $\pm 8$  Vdc

### Amplitude Modulation

**Depth:** 0 to 95% at output levels of +8 dBm and below (+10 dBm in uncorrected mode). AM available above these output levels but not specified.

**Resolution:** 1%, 10 to 95% AM; 0.1%, 0 to 9.9% AM

**Incidental PM:** (at 30% AM): 0.15 to 640 MHz, < 0.12 radian peak;

640 to 1280 MHz, < 0.09 radian peak

**Incidental FM:** (at 30% AM): 0.15 to 640 MHz, < 0.12  $\times$  f<sub>mod</sub>;

640 to 1280 MHz, < 0.09  $\times$  f<sub>mod</sub>

**Indicated Accuracy:**  $\pm 5\%$  of reading  $\pm 1\%$  AM. Applies for rates given in table below, internal or external mode, for depths  $\leq 90\%$ .

#### Rates and Distortion with Internal or External Modulating Signal:

Frequency Range	AM Rate	AM Distortion		
		0 to 30% AM	30 to 70% AM	70 to 90% AM
0.15 to 1 MHz	dc to 1.5 kHz	2%	4%	5.75%
1 to 10 MHz	dc to 5 kHz	2%	4%	5.75%
10 to 1280 MHz	dc to 10 kHz	2%	4%	5.75%

### Frequency Modulation

**FM Rates:** (1 dB bandwidth): External ac, 20 Hz to 100 kHz; external dc, dc to 100 kHz

**FM Deviation:** 25 to 200 kHz, depending on carrier frequency

**Indicated FM Accuracy:**  $\pm 8\%$  of reading plus 10 Hz (50 Hz to 20 kHz)

**FM Resolution:** 100 Hz for deviations < 10 kHz, 1 kHz for deviations  $\geq 10$  kHz

**Incidental AM:** (AM sidebands at 1 kHz rate and 20 kHz deviation):

< -72 dBc, f<sub>c</sub> < 640 MHz; < -65 dBc, f<sub>c</sub>  $\geq$  640 MHz

**FM Distortion:** < 1.7% for rates < 20 kHz, < 1% for rates < 1 kHz

**Center Frequency Accuracy and Long-Term Stability in AC Mode:**

Same as CW mode

### Supplemental Characteristic

**Frequency-Switching Speed:**<sup>5</sup> From 420  $\mu$ s to 12.5 ms, depending on the programming mode

### 8663A Specifications

The 8663A signal generator is related to the 8662A in both concept and structure. Like the 8662A, the 8663A is an extremely low phase noise signal source, incorporating signal generator modulation capabilities and output characteristics. The 8663A also offers increased frequency range to 2560 MHz, increased output level to +16 dBm, and the addition of phase and pulse modulation while maintaining high spectral purity. The result is a highly flexible and powerful signal generator that uses and extends the proven circuitry of the 8662A. Thus, the 8662A and 8663A share many of the same specifications.

### Frequency

**Range:** 100 kHz to 2560 MHz (2559.9999996 MHz)

**Resolution:** 0.1 Hz (f<sub>c</sub> < 640 MHz);

0.2 Hz (640 MHz to 1280 MHz);

0.4 Hz (f<sub>c</sub>  $\geq$  1280 MHz)

**Accuracy, Stability, and Internal Reference Oscillator:** Identical to 8662A

### Spectral Purity

(See 8662A specifications)

**Spurious Signals:** Identical to 8662A, except that for f<sub>c</sub> between 1280 and 2560 MHz the spurious non-harmonics are -78 dBc; the sub-harmonically related (f/2, 3f/2, etc.) between 640 and 1280 MHz are -70 dBc and between 1280 and 2560 MHz are -40 dBc; and the power-line (60 Hz) or microphonically generated spurious are -65 dBc.

**Harmonics:** < -30 dBc,  $\leq +13$  dBm output; < -25 dBc, +13 dBm to +16 dBm output, f<sub>c</sub> < 1280 MHz; < -25 dBc, f<sub>c</sub>  $\geq$  1280 MHz

### Output

**Level Range:** +16 dBm to -129.9 dBm

**Resolution:** 0.1 dB

**Absolute Level Accuracy:** (+15° C to +45° C):  $\pm 1$  dB, +16 dBm to -119.9 dBm;  $\pm 3$  dB, -120 dBm and below

**SWR:** < 1.5

### Amplitude Modulation

**Depth:** 0 to 95% at levels of +10 dBm and below

**Resolution:** 0.1%

**Incidental FM:** (at 30% AM): Identical to 8662A except: < 0.3  $\times$  f<sub>mod</sub> for 1280  $\leq$  f<sub>c</sub> < 2560 MHz

**Indicated Accuracy:**  $\pm 6\%$  of reading  $\pm 1\%$  AM (400 Hz and 1 kHz, depth 90%)

**AM Bandwidth:** (1 dB): dc to > 1.5 kHz, 0.15 MHz  $\leq$  f<sub>c</sub> < 1 MHz;

dc to > 5 kHz, 1 MHz  $\leq$  f<sub>c</sub>  $\leq$  10 MHz; dc to > 10 kHz, f<sub>c</sub> > 10 MHz;

external dc coupling. External ac coupling or internal;

low-frequency coupling is 20 Hz.

**Distortion:** (400 Hz and 1 kHz): < 2% (0 to 30% AM); < 3% (30 to 70% AM); < 4% (70 to 90% AM)

### Frequency Modulation

**FM Rates:** (1 dB bandwidth): External ac, 20 Hz to 100 kHz, external dc, dc to 100 kHz

**Maximum Allowable Peak Deviation:** Identical to 8662A for f<sub>c</sub> between 100 kHz and 1280 MHz. Up to 400 kHz for f<sub>c</sub> between 1280 and 2560 MHz.

**Indicated FM Accuracy:** (50 Hz to 20 kHz):  $\pm 7\%$  of setting +10 Hz

**FM Resolution:** 100 Hz to 1 kHz, depending on f<sub>c</sub> and deviation setting

**Incidental AM:** (AM sidebands at 1 kHz rate and 20 kHz deviation):

< -72 dBc (10  $\leq$  f<sub>c</sub> < 2560 MHz)

**FM Distortion:** < 1% (400 Hz and 1 kHz rates); < 1.7% (rates less than 20 kHz)

<sup>1</sup> In the remote mode it is possible to have microprocessor clock-related spurious signals spaced 3 MHz apart at an absolute level of typically less than -145 dBm.

<sup>2</sup> Spurious signals can be up to 3 dB higher in the dc FM mode.

<sup>3</sup> f/2 spurs not specified for carrier frequencies above 850 MHz.

<sup>4</sup> At a 50 Hz line frequency, power-line or microphonically-related spurious signals may be up to 3 dB higher and appear at offsets as high as 1 kHz from the carrier.

<sup>5</sup> Due to automatic leveling loop bandwidth changes, brief (30 ms) level inaccuracies may occur when switching through 150 kHz and 1 MHz RF output frequencies.



**Phase Modulation (Option 002)**

**Maximum Peak Phase Deviation:** From  $\pm 25^\circ$  for  $f_c$  between 120 and 160 MHz to  $\pm 400^\circ$  for  $f_c$  between 1280 and 2560 MHz  
**Maximum Rate:** From 10 kHz for  $f_c$  between 0.15 and 10 MHz to 10 MHz for  $f_c$  between 640 and 2560 MHz  
**Phase Deviation Resolution:**  $1^\circ$  ( $0.1 \leq f_c < 640$  MHz);  $2^\circ$  ( $640 \leq f_c < 1280$  MHz);  $4^\circ$  ( $1280 \leq f_c < 2560$  MHz)  
**Phase Modulation Distortion:** 10% at maximum rate

**Biphase Modulation (BPSK)**

Biphase modulation is available on the standard 8663A for  $f_c$  less than 640 MHz and available for all  $f_c$  with Option 002.

**Deviation:**  $\pm 90^\circ$

**Carrier Null when Modulated with 1 MHz, 50% Duty Cycle**

**Square Wave:**  $>25$  dBc

**Modulation Input Required:** TTL positive true. The internal modulation oscillator can be used for 50% duty-cycle modulation. External input is on rear panel.

**Pulse Modulation<sup>1</sup>**

**Pulse On/Off Ratio:**  $>80$  dB (50 to 2560 MHz)

**Pulse Rise/Fall Time:**  $<250$  ns (50 to 120 MHz);  $<800$  ns (120 to 640 MHz);  $<100$  ns ( $f_c \geq 640$  MHz)

**Pulse Repetition Frequency** (50% duty cycle):

**Internal:** 10 Hz to 99.9 kHz

**External:** 10 Hz to 2 MHz, 50 MHz  $< f_c < 640$  MHz;

10 Hz to 5 MHz,  $f_c > 640$  MHz

**Internal Modulation Oscillator**

**Rates:** 10 Hz to 99.9 kHz

**Frequency Resolution:** 3 digits

**Frequency Accuracy:** Same as reference oscillator

**Output Level** (available on rear panel): 1 V peak into 600  $\Omega$

**Output Impedance:** 600  $\Omega$

**Flatness** (referenced to 1 kHz):  $< \pm 1\%$

**Distortion:**  $< 1\%$

**Other 8662A and 8663A Information**

**Remote Programming:** The GPIB interface is standard on the 8662A and 8663A signal generators. All functions controlled from the front panel, with the exception of the line switch, are programmable with the same accuracy and resolution as in manual mode.

**Operating Temperature Range:**  $0^\circ$  C to  $+55^\circ$  C

**Leakage:** Meets radiated and conducted limits of MIL-STD-461A methods RE02 and CE03 as well as BVDE 0871

**Power Requirements:** 115 (90 to 126) V or 230 (198 to 252) V; 48 to 66 Hz; 450 VA max

**Size:**

8662A: 178 mm H x 425 mm W x 572 mm D (7 in x 16.75 in x 22.5 in)

8663A: 178 mm H x 425 mm W x 642 mm D (7 in x 16.75 in x 25.3 in)

Note: depth includes front panel depth of 45 mm (1.75 in).

**Weight:** 8662A: net, 30 kg (65.5 lb); shipping, 36 kg (80 lb)

8663A: net, 33.8 (74 lb); shipping, 40 kg (88 lb)

**Key Literature**

Synthesized Signal Generator 10 kHz to 1280 MHz  
 Technical Data, p/n 5953-8402

Synthesized Signal Generator 100 kHz to 2.56 GHz  
 Technical Data, p/n 5953-8376

**Ordering Information**

**8662A** 1280 MHz Signal Generator<sup>2</sup>

**Opt 001** RF Connectors on Rear Panel Only

**Opt 003** Specified SSB Phase Noise for 640 MHz Output

**Opt 907** Front Handle Kit (5062-3990)

**Opt 908** Rack Flange Kit (5062-3978)

**Opt 909** Rack Flange Kit w/Front Handles(5062-3984)

**Opt 910** Two Sets of Operating and Service Manuals (08662-90069)

**Opt W30** Extended Repair Service (see page 70)

**Opt W32** Calibration Service (see page 70)



11721A

**8663A** 2560 MHz Signal Generator<sup>2</sup>

**Opt 001** RF Connectors on Rear Panel Only

**Opt 002** Wideband Linear Phase Modulation

**Opt 003** Specified SSB Phase Noise for 640 MHz Output

**Opt 907** Front Handle Kit (5061-9690)

**Opt 908** Rack Flange Kit (5061-9678)

**Opt 909** Rack Flange Kit w/Front Handles (5061-9684)

**Opt 910** Additional Operation and Calibration Manual (08663-90069) and Service Manuals (08663-90071)

**Opt 915** Add Service Manual (08663-90071)

**Opt W30** Extended Repair Service (see page 70)

**Opt W32** Calibration Service (see page 70)

**11714A** Service Support Kit (required for servicing 8662A/8663A)

<sup>1</sup> Pulse modulation is available for  $f_c < 50$  MHz but is unspecified.

<sup>2</sup> GPIB cables not supplied. For description and price, see page 568.

 Indicates QuickShip availability.

**11721A Frequency Doubler**

The 11721A doubler is an ideal accessory for extending the usable frequency range of signal generators, frequency synthesizers, or other signal sources. Operating on input frequencies of 50 MHz to 1300 MHz, it provides a doubled output in the range of 100 MHz to 2600 MHz. The 11721A will work well with any RF source with an output in the range of 50 to 1300 MHz.

The 50  $\Omega$  passive circuit of the 11721A offers low conversion loss, low spurious, and excellent flatness over its entire frequency range when operated above  $+10$  dBm.

**11721A Specifications**

**Input Frequency Range:** 50 to 1300 MHz

**Output Frequency Range:** 100 to 2600 MHz

**Conversion Loss** ( $+13$  dBm input, 50 to 1280 MHz):  $< 15$  dB

**Spurious Referenced to Desired Output Frequency f:**

( $+13$  dBm input with harmonics  $\leq -50$  dBc, 50 to 1280 MHz):

$f/2$ ,  $-15$  dB;  $3f/2$ ,  $-15$  dB

**Input SWR:** 1.5 typical

**Input/Output Impedance:** 50  $\Omega$  nominal

**Operating Temperature Range:**  $0^\circ$  to  $50^\circ$  C

**Connectors:** Input, type-N male; output, type-N female

**Size:** 20.5 mm H x 30 mm W x 161 mm D (.19 in x 1.19 in x 6.38 in)

**Weight:** Net, .02 kg (0.5 lb); shipping, 0.4 kg (1 lb)

**Ordering Information**

**11721A** Frequency Doubler

**Opt W30** Extended Repair Service (see page 567)



83711B  
83712B  
83731B  
83732B



Typical single-sideband phase noise at 50 MHz, 1 GHz and 20 GHz, 25° C, CW mode. Offsets less than 100 Hz require the high stability timebase, Option 1E5.

### 83711B/12B and 83731B/32B Signal Sources

The 83711B/12B synthesized CW generators and 83731B/32B synthesized signal generators set new standards for performance at prices that are surprisingly affordable. No longer will you have to give up frequency coverage, modulation, or reliability to meet your budget. These signal sources will perform beyond your expectations at a price within your reach.

### Clean Signals with Plenty of Power

Choose the 83711B/83731B, 1 to 20 GHz, or the 83712B/ 83732B, 10 MHz to 20 GHz, for your receiver and system test applications. Fundamental oscillators and switched low-pass filters deliver < -55 dBc harmonics, eliminate subharmonics, and suppress spurious to < -60 dBc. These signal sources provide plenty of output power (typically > +14 dBm), while spectral purity is maintained even at high power levels (typical output power at frequencies below 1 GHz is +20 dBm). These signal sources deliver >100 dB dynamic range. Level resolution is 0.01 dB with typical accuracy of ± 1.0 dB at any frequency or power level. User Level Correction simplifies generating accurate, leveled power at distant test ports.

### 83731B and 83732B Provide Unmatched Modulation Performance

Sophisticated modulation lets you simulate real-world signals. Test state-of-the-art radar and EW receivers with high-fidelity pulse modulation. < 10 ns pulse rise/fall times, < 25 ns pulse width, and > 80 dB pulse on/off ratio give you the performance you need to verify modern receivers. A built-in multimode pulse generator adds the flexibility to generate triggered, doublet and gated burst pulse modes.

In addition, logarithmic and linear AM is a standard feature in the 83731B/32B. Use the > 60 dB depth log AM and the fast pulse modulation simultaneously (scan modulation) for accurate simulation of antenna scanning patterns, or sweep power linearly and accurately to test power-sensitive devices.

The 83731B/32B offers unmatched performance for testing satellite communications and telemetry receivers. 10 MHz peak FM and optional 100 radians peak phase modulation deviations, combined with the highest-modulation index available (> 300 for FM), simplify simulation of these difficult-to-generate signals. The 83731B/32B remain fully synthesized even at high-modulation indices, eliminating the troublesome frequency drift of other signal sources.

Real-world signals often combine two or more modulations. The 83731B/32B let you use all three modulations simultaneously with optional independent internal modulation generator without any degradation in performance. FM and phase modulation cannot be applied simultaneously.

### Versatile and Reliable

The 83711B/12B and 83731B/32B signal sources are the recommended local oscillators for the 8970B noise figure meter. Low broadband noise minimizes errors in measurements of low gain devices. Use these signal sources with the 83550 series millimeter-wave modules to generate signals to 110 GHz. All front-panel functions are completely GPIB-programmable and SCPI-compatible.

These signal sources are designed to remain within factory specifications for the entire life of the instrument. The recommended two-year performance verification cycle minimizes downtime and cost of ownership. If a unit ever drifts, automated adjustment routines can be run to return the unit to factory performance in less than six hours. Extensive use of surface-mount technology and a minimum number of adjustments combine to deliver an estimated MTBF of more than 20,000 hours. Built-in functional verification routines speed servicing.

### Specifications

#### Frequency Characteristics

##### Frequency Range:

- 83711B, 1.0 to 20 GHz
- 83712B, 10 MHz to 20 GHz
- 83731B, 1.0 to 20 GHz
- 83732B, 10 MHz to 20 GHz

**Frequency Resolution:** 1 kHz, 1 Hz with Option 1E8

#### Internal Reference Oscillator

**Frequency:** 10 MHz

**Timebase Stability:**

	Standard Timebase	Option 1E5
<b>Aging Rate</b>	< 1.0 x 10 <sup>-6</sup> /day	< 1.5 x 10 <sup>-6</sup> /day
<b>Temperature</b>	< 5 x 10 <sup>-6</sup>	< 1 x 10 <sup>-7</sup>
<b>Line Voltage</b>	N/A	< 5 x 10 <sup>-10</sup> (10% change in voltage)

**Timebase Accuracy** = ± aging rate ± temperature effects ± line voltage effects

#### Output Characteristics

**Output Power** (with Option 1E1): 0.01 to 1 GHz + 13 dBm

**Maximum Leveled Output Power:** 1 to 18 GHz + 10 dBm; 18 to 20 GHz + 8 dBm

**Minimum Leveled Output Power:** -4 dBm; with Option 1E1, -110 dBm

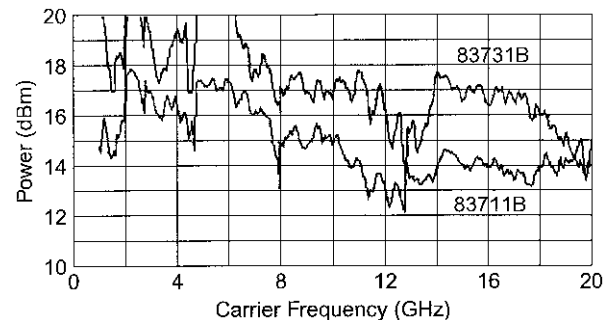
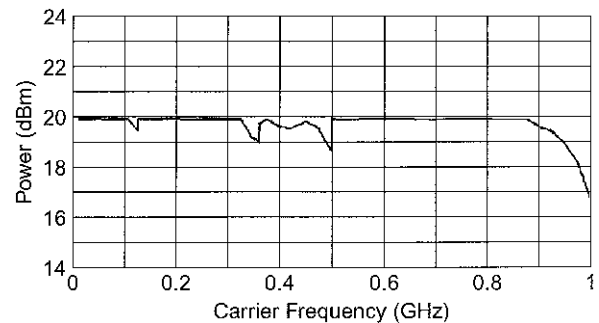

**Resolution:** 0.01 dB

**Accuracy** (–4 dBm to maximum specified leveled output power):

10 MHz to 50 MHz,  $\pm 1.3$  dB

50 MHz to 20 GHz,  $\pm 1.0$  dB

**Accuracy** (over all specified temperatures, and power levels):

10 MHz to 50 MHz,  $\pm 2.3$  dB

50 MHz to 20 GHz,  $\pm 2.0$  dB

**Flatness:**  $\pm 0.5$  dB

## Spectral Purity

### Harmonics:

83711B/83712B,  $< -50$  dBc (at levels  $< +6$  dBm)

83731B/83732B,  $< -55$  dBc (at levels  $< +6$  dBm)

**Sub-Harmonics:** None

**Non-Harmonic Spurious** ( $> 3$  kHz):  $-60$  dBc

**Phase Noise** (@ 10 kHz offset): 500 MHz:  $-103$  dBc/Hz;

2 GHz:  $-92$  dBc/Hz; 18 GHz:  $-76$  dBc/Hz

(Phase noise decreases 6 dB/octave below 500 MHz and reaches a floor of  $< -140$  dBc/Hz)

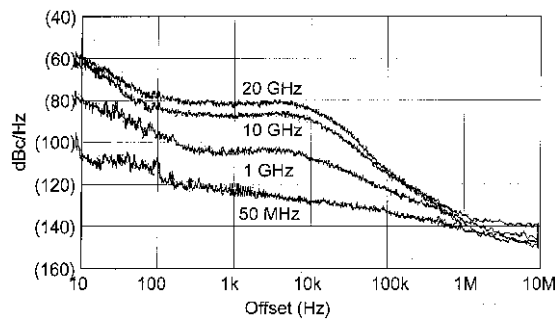

Typical single-sideband phase noise at 50 MHz, 1 GHz, 10 GHz and 20 GHz, 25° C, CW mode. Offsets less than 100 Hz require the high-stability timebase, Option 1E5.

### SSB phase noise (dBc/Hz, CW mode):

Carrier Freq.	Offsets			
	100 Hz	1 kHz	10 kHz	100 kHz
0.5 to $< 1$ GHz	-78	-92	-103	-115
1 to $< 2$ GHz	-73	-83	-92	-107
2 to $< 5$ GHz	-70	-78	-83	-100
5 to $< 10$ GHz	-69	-78	-82	-100
10 to 20 GHz	-65	-73	-76	-100

Phase noise decreases 6 dB/octave below 500 MHz and reaches a floor of  $< -140$  dBc/Hz.

## General Specifications

**Operating Temperature Range:** 0° to +55° C

**Size:** 133 mm H x 426 mm W x 498 mm D (5.2 in x 16.8 in x 19.6 in)

**Weight:**  $< 16$  kg (35 lb)

**Power:** 90 to 132 V, 48 to 440 Hz; 198 to 264 V, 48 to 66 Hz; 400 VA max.

**EMC:** Meets or exceeds EN55011/CISPR 11/1990, Class A and

MIL-STD-461C Part 2 RE02, CE03, CS02, RS03

## 83731B, 83732B Modulation Specifications

### Pulse Modulation

**On/Off Ratio:**  $> 80$  dB

**Rise/Fall Times:**  $< 10$  ns

**Minimum Pulse Width:**  $< 25$  ns, 1 to 20 GHz

## Internal Multimode Pulse Modulation Source

**Modes:** Internal free-run, triggered, doublet, and gated burst modes

**Pulse Repetition Frequency:** 3 Hz to  $> 3$  MHz

**Pulse Width:** 25 ns to 419 ns

**Pulse Delay:**  $-419$  ms to  $+419$  ms, free-run mode; 225 ns to 419 ms, triggered mode

**Minimum Pulse Parameter Resolution:** 25 ns

## Frequency Modulation

**Rates:** 1 kHz to 1 MHz

**Maximum Deviation:** 10 MHz pk, 2 to 20 GHz; 5 MHz pk, 1 to 2 GHz; decreases by a factor of 2 for each octave below 1 GHz

**Maximum Modulation Index:**  $> 300$

## Option 800 Analog Phase Modulation

**Sensitivity:** Two ranges

**Maximum Deviation:**

Frequency	Low range	High range
2 to 20 GHz	4 rad	200 rad
1 to 2 GHz	2 rad	100 rad
0.5 to 1 GHz	1 rad	50 rad
0.256 to 0.5 GHz	0.5 rad	25 rad

## Logarithmic Amplitude Modulation

**Depth:**  $> 60$  dB

**Sensitivity:**  $-10$  dB/V

**Step Response:**  $< 5$   $\mu$ s for 50 dB step

## Linear Amplitude Modulation

**Sensitivity:** Two ranges selectable: 30%  $V_{pk}$  + 100%  $V_{pk}$

**Maximum Depth:** 90% ( $> 90\%$  typical)

## Key Literature

83711B/12B and 83731B/32B Technical Data, p/n 5963-6615E

## Ordering Information

**83711B** Synthesized CW Generator

**83712B** Synthesized CW Generator

**83731B** Synthesized Signal Generator

**83732B** Synthesized Signal Generator

The following options apply to all models:

**Opt 1E1** Add 110 dB Output Step Attenuator

**Opt 1E2** Add High-Performance Modulation Generator<sup>1</sup>

**Opt 1E5** Add High-Stability Timebase

**Opt 1E8** Add 1 Hz Frequency Resolution

**Opt 1E9** 3.5 mm RF Output Connector

**Opt 800** Add Analog Phase Modulation<sup>1</sup>

**Opt 0B0** Delete Manual Set

**Opt 0B1** Extra User's Guide

**Opt 0BV** Service Manual (Component Level)

**Opt 0BW** Service Manual (Assembly Level)

**Opt 0BX** Service Manual (Assembly

and Component Level)

**Opt 1CM** Rackmount Kit (p/n 5062-3977)

**Opt 1CP** Rackmount and Handle Kit (p/n 5062-3983)

**Opt 1CR** Rack Slide Kit (p/n 1494-0059)

**Opt W30** Three Additional Years Return-to-Agilent Service:

**83711B**

**83712B**

**83731B**

**83732B**

<sup>1</sup> Available on the 83731B/32B only.

E6432A

- Broadband frequency coverage, 10 MHz to 20 GHz
- Amplitude range  $-90$  dBm to  $+17$  dBm (Opt 1E1)
- High power output of  $+20$  dBm 2 GHz to 20 GHz (Opt UNF)
- 1 Hz frequency resolution
- Less than  $400$   $\mu$ s frequency switching time
- Excellent harmonics, spurious, and phase noise
- AM, FM, and pulse modulators
- *VXIplug&play* driver included



E6432A

### Optimized for Automated Test Systems

The E6432A microwave synthesizer is designed especially for demanding performance in modern automated test systems. Rather than using slow and heavy magnetically tuned circuits, it uses small, lightweight, and fast VCO's and mixers to deliver fully synthesized microwave signals. It is register-based in order to deliver its promised switching speeds to the user in real-world applications. Communication with the E6432A is through its *Plug&Play* driver. This driver is an integral part of the E6432A and should be thought of as an extension of the instrument firmware.

### Fast Frequency and Amplitude Switching

Tuning between any two arbitrary frequencies requires less than  $400$   $\mu$ s and is typically  $220$   $\mu$ s. Amplitude-only switching between any two power levels within the vernier range requires less than  $50$   $\mu$ s. If the optional step attenuator requires a change, switching time is slowed to  $25$  ms. This fast switching brings a direct benefit of decreased measurement time in scenarios where throughput is currently limited by the time it takes to retune the signal source. Examples of such scenarios are antenna testing and satellite payload testing, where large numbers of frequencies are measured. Another example is RFIC and MMIC manufacturing, where time budgets for testing each device are measured in milliseconds.

### Comprehensive List and Triggering Modes

A deep list mode of up to 128k entries provides sequence memory for very long test scenarios. Each entry may hold settings for frequency, amplitude, attenuator setting, settling and blanking modes, and a marker. The host computer constructs the list array and downloads the array into the E6432A hardware prior to execution.

Triggering modes are free-run, sync, and triggered. A repeat mode may be enabled and active in any trigger mode. All events available on the front panel are also available on the TTL trigger bus. Interrupts may also be enabled for specific events.

### Spectrally Pure: Free of Harmonics and Spurious

The PC assembly shielding technology is patented. Critical circuitry is contained within two hybrid thin- and thick-film microcircuits. DC to DC converters inside the module carefully filter and re-regulate the VXI mainframe power supplies. These features combine to give the E6432A performance superior to other VXI signal sources, rivaling the finest sources available.



**Specifications****Frequency****Range:** 10 MHz to 20 GHz**Accuracy:** depends on external time base**Resolution:** 1 Hz**Switching time:** 220  $\mu$ s typical**Amplitude****Output range:**

Standard: -20 to +17 dBm

Option 1E1: -90 to +16 dBm

Option UNF: +20 dBm maximum, (2 to 20 GHz)

Option UNH: +13 dBm maximum, (10 MHz to 2 GHz)

**Vernier accuracy:**-10 to +10 dBm:  $\pm 0.5$  dB-20 to +20 dBm:  $\pm 1.0$  dB**Resolution:** 0.02 dB**Switching time:**Vernier: 40  $\mu$ s typical

Attenuator: 20 ms typical

**External ALC range:** 40 dB**Flatness:**-10 to +10 dBm:  $\pm 2.5$  dB-90 to +20 dBm:  $\pm 4.1$  dB**VSWR @ 50:** 1.6:1 typical**Harmonics:**10 MHz to 2 GHz:  $< -25$  dBcOption UNH:  $< -55$  dBc2 to 20 GHz:  $< -55$  dBc,  $< -65$  dBc typical**Spurious responses:** $< -55$  dBc $< -70$  dBc typical**SSB phase noise (any carrier freq.):**100 Hz offset:  $< -67$  dBc/Hz10 kHz offset:  $< -90$  dBc/Hz**Modulation****Amplitude:**

Rate: DC to 100 kHz

Depth: 0 to 40 dB

Accuracy:  $< 8\%$  of depth**Frequency:**

Rate: 100 kHz to 8 MHz

50 kHz to 10 MHz typical

Maximum deviation:  $> 8$  MHz**Pulse (2 GHz to 20 GHz):**On/Off ratio:  $> 80$  dBRise/Fall time:  $< 10$  ns

PRF range: 10 Hz to 10 MHz

**Pulse width:**leveled:  $> 2.5$   $\mu$ sunleveled:  $> 15$  ns**Vernier accuracy:**leveled:  $\pm 0.5$  dBunleveled:  $\pm 0.5$  dB typicalVideo feedthrough:  $< 10$  mV**Digital I/Q**

Modulation bandwidth: 40 MHz

Dynamic range:  $\geq 40$  dBError Vector Magnitude:  $< 2\%$ (2 MS/s, QPSK, power  $\leq 0$  dBm)**General Specifications****VXI Characteristics****VXI device type:** Register-based**Data transfer bus:** A16, A24, D16/32 slave only**Size:** C**Slots:** 3**Connectors:** P1/P2**Shared memory:** none**VXI busses:** TTL trigger bus**C-size compatibility:** n/a**VXI plug&play framework:** Microsoft WindowsNT service pack 3 or greater**Cooling/Slot****Watts/slot:** 34.3**DP mm H2O:** 1.1**Air flow liter/s:** 4.0**Module Current**

	$I_{EM}$ (A)	$I_{DM}$ (A)
+5 V:	10	2
+12 V:	2.4	0.8
-12 V:	1.0	0.05
+24 V:	0.4	0.5 <sup>1</sup> (0.06)
-24 V:	0.15	0.03
-5.2 V:	2.35	0.1
-2 V:	0	0

<sup>1</sup>step attenuator

**Key Literature**

E6432A Brochure, p/n 5967-6313E

E6432A Technical Specifications, p/n 5968-1242E

E6432A Product Overview, p/n 5967-6178E

E6432A Configuration Guide, p/n 5967-6272E

Test System and VXI Products Catalog, p/n 5968-3698E

An Introduction to the E6432A VXI plug&amp;play Driver, p/n 5968-3660E

**Ordering Information****E6432A** VXI Microwave Synthesizer**Opt 1E1** 70 dB step attenuator**Opt UK6** Commercial calibration certificate with test data**Opt UNF** High output power (+20 dBm) 2 GHz to 20 GHz**Opt UNG** Add I/Q modulator**Opt UNH** Improved spectral purity 10 MHz to 2 GHz**Opt 002** Extended frequency modulation**Opt W30** 3 yrs Customer Return Repair Service**Opt W50** 5 yrs Customer Return Repair Service

E7501A

- 3-slot VXI register based 0.01 to 20 GHz synthesizer
- 1 slot, 3 channel VXI 100/50 MSA/s waveform generators
- -90 to +20 dBm output power available
- <200  $\mu$ s switching time (typical)
- AM, FM and pulse modulation
- E8403A 13-slot VXI mainframe
- PC with Windows NT, and IEEE 1394 VXI interface
- Signal Studio's Analog Generation and Simulation Software

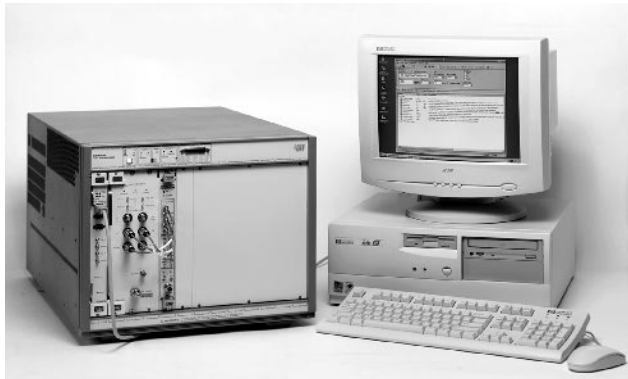

E7501A Arbitrary Analog Signal Development System

5

### E7501A Arbitrary Analog Signal Development System

The E7501A arbitrary analog signal development system combines a compact, fast-switching microwave VXI synthesizer and a compact, multi-channel VXI arbitrary waveform generator with the Agilent arbitrary analog signal development software, to deliver a 4-slot, VXI-based microwave stimulus solution that provides precise, arbitrary AM, FM, and pulse modulated signals to a test environment.

The arbitrary analog signal development software—a component of Agilent Technologies Signal Studio—simplifies creation and delivery of arbitrarily modulated RF and microwave signals with a single, easy-to-use interface. The software also automates the process of characterizing and correcting for ATE signal path effects on output power and AM and FM characteristics. This allows precisely known modulated signals to be delivered to a test device, even when using signal routing matrixes in a complex ATE system.

#### VXI Microwave Synthesizer

The E6432A 3-slot VXI fast-switching synthesizer provides 10 MHz to 20 GHz frequency coverage over a wide output range. Frequency changes over any two frequencies within the full band of the synthesizer is typically < 170  $\mu$ secs. Power changes within 40 dB ALC range (with no frequency change) is typically <50  $\mu$ secs. The VXI synthesizer also includes standard AM, FM, and Pulse modulators.

#### VXI Arbitrary Waveform Generator

The Racal Instruments 3153 3-channel, 1-slot VXI arbitrary waveform generator provides three arbitrary waveform generators that can operate independently or in a master/slave configuration. Channel 1 provides a 100 MSA/sec output with 2 Mpoints of internal memory, while channels 2 and 3 each provide a 50 MSA/sec output with 4 Mpoints of internal memory. Each channel also has its own independent sample clock, trigger input, and sequencing generator. Standard, internal reconstruction filters of 50 MHz, 25 MHz, and 250 kHz are provided.

### Stimulus-Focused Application Software

The arbitrary analog signal development software, a component of the Agilent Signal Studio family of stimulus-focused application software, allows you to define and manage the required stimulus signals. The application software determines when and how to control the hardware to achieve the desired output signal.

The easy-to-use, graphical user interface (GUI) enables you to quickly define and create a modulated signal. Once the desired stimulus signal is achieved, simply save the total signal plan for later recall and use.

### Specifications

#### Frequency

**Range:** 10 MHz to 20 GHz  
**Accuracy:** same as time base  
**Resolution:** 1 Hz  
**Switching time:** <400  $\mu$ s

#### Amplitude

**Range:** -20 to +17 dBm  
 Option 1E1: -90 to +16 dBm  
**Vernier accuracy:**  $\pm$ 0.5 dB from -10 to +10 dBm  
 $\pm$ 1.3 dB from -20 to +20 dBm

**Resolution:** 0.02 dB  
**Switching time:** <400  $\mu$ s across ALC range,  
 <20 ms with attenuator step change

**External ALC range:** 40 dB  
**Flatness (w/opt 1E1):**  $\pm$ 4.1 dB from -90 to +20 dBm  
 $\pm$ 3.1 dB from -10 to +10 dBm

**VSWR @ 50:** 1.6:1 typical

#### Modulation

##### Amplitude:

Rate ( $\pm$ 1 dB): DC to 100 kHz  
 Depth normal ALC: -20 dBm  
 Depth deep ALC: 45 dB <Pmax (<2 GHz)  
 50 dB <Pmax (>2 GHz)  
 Accuracy: < 6% (30% depth, 1 kHz)  
 Sensitivity: 100%/V  
 AM distortion: (from arb specs) sine wave

##### Frequency (standard):

Rate: 100 kHz to 1 MHz  
 (typ 10 MHz)  
 Deviation: >8 MHz  
 Sensitivity vs. rate: 1MHz/V  
 Sensitivity accuracy: 30%  
 Sensitivity flatness:  $\pm$ 1 dB (100 kHz to 1 MHz)  
 FM distortion: (from arb specs) sine wave

##### Pulse:

On/off ratio: > 68 dB (<2 GHz)  
 > 80 dB (>2 GHz)  
 Rise/fall time: <25 ns (10%–90%)  
 PRF range: 10 Hz to 10 MHz (ALC on)

##### Pulse width: >50 ns (unleveled)

Level accuracy (pw>2.5 ms):  $\pm$ 0.5 dB

**Vernier accuracy:**  $\pm$ 1.6 dB (leveled)

**Video feedthrough:** <5% (<2 GHz); <10 mV (>2 GHz)

### Key Literature

E7501A Product Overview, p/n 5980-1204E  
 E7501A Configuration Guide, p/n 5980-1205E

### Ordering Information

**E7501A** 10 MHz to 20 GHz Arbitrary Analog Signal Development System  
 See configuration guide for detailed ordering information.

- Fully synthesized (phase-locked) CW, step, and ramp modes
- 2 MHz swept frequency accuracy
- Power flatness correction
- Broad 20 GHz frequency coverage
- +17 dBm output power at 20 GHz
- Internal pulse generator

83751A  
83751B  
83752A  
83752B



83752A

### 83750 Series Sweepers

The 83750 sweepers bring outstanding synthesized performance to the component-test marketplace. They deliver the best performance for the price in general-purpose benchtop, swept test, or scalar applications.

#### Excellent Spurious Performance

The latest technological advances in fundamental oscillator design provide up to 20 GHz of frequency coverage with superior harmonic suppression and no subharmonics. When this excellent spurious performance is combined with high-output power capabilities, high-measurement dynamic range is achieved.

#### Superior Accuracy and Stability

The Agilent 83750 synthesized sweepers provide superior accuracy and stability while maintaining the speed of analog sources. Fully-synthesized CW, stepped, and ramp sweep modes are available in broadband and narrowband operation. The synthesis capabilities are particularly useful for the characterization of narrowband devices, in which the frequency instabilities of open-loop sources become most apparent.

#### Excellent Output-Power Flatness and Accuracy

Excellent output-power flatness and accuracy can be translated to the input port of the device-under-test with the power flatness correction feature of these sources. This feature uses a power meter to create an array of power corrections that compensate for power variations in the measurement path between the source and the test device.

#### Swept Testing of Frequency Translation Devices

Swept testing of frequency translation devices can be achieved simply and economically with the 83570 series synthesized sweepers. A traditionally difficult measurement, sweeping the RF and local oscillator (LO) input ports at a fixed offset over a wide frequency span, is easy to implement with superior frequency accuracy by positioning two synchronously tracking 83750s in a two-tone configuration. With broadband frequency coverage and excellent performance, the 83750 synthesized sweepers are ideal stimuli for frequency translation measurements.

#### Scalar Measurement Applications

The 83750 series make optimal companion sources for scalar-measurement applications. Full compatibility is available via the 8757 system interface bus. The 8757D scalar analyzer and 83750 series have a complementary design that achieves superior frequency accuracy, power accuracy and flatness while significantly reducing measurement uncertainty. In addition, the 83750's high-power and low-harmonic capabilities increase the spurious-free measurement dynamic range of scalar systems. Ten independent, continuously variable markers and a marker sweep function allow fast, efficient analysis of the test device at or between critical measurement frequencies. CW, stepped, ramp, or power sweep modes are available for device characterization. A 25 dB power sweep range is particularly useful for compression measurements of active devices such as amplifiers and mixers.

#### High-Power Capability

The high-power models 83751B and 83752B provide +17 dBm output power with  $-20$  dBc harmonics from 2 to 20 GHz. This high-power capability eliminates the need to externally amplify the signal for test devices that require high-input power levels. When Option 1EE (source module interface connector and extension cable) is added, these sources can directly drive the 83550 series mm-wave source modules to provide waveguide frequency coverage up to 110 GHz. All Agilent 83750 sweepers with Option 1EE automatically provide bias, power flatness correction, and internal leveling for the 83550 series source modules.

#### Two Operating Languages

83750 sweepers offer two operating languages to ensure compatibility with instruments today and in the future. The default language is SCPI (Standard Command for Programmable Instruments), an industry standard. The second operating language employs 8350 mnemonics to provide programming compatibility with 8350-based measurement systems.

83751A  
83751B  
83752A  
83752B

## Specifications

### Frequency Characteristics

#### Frequency Range

**83751B:** 2 to 20 GHz  
**83752B:** 0.01 to 20 GHz

### Internal Reference Oscillator

**Frequency:** 10 MHz

#### Timebase Stability

**Standard Timebase:**  $\pm 10 \times 10^{-6}$   
**High-Stability Timebase (Option 1E5)**  
**Aging Rate:**  $5 \times 10^{-10}/\text{day}$ ;  $1 \times 10^{-7}/\text{year}$   
**Temperature Effects:**  $1 \times 10^{-10}/^\circ\text{C}$   
**Line Voltage Effects:**  $5 \times 10^{-10}$  (10° change in voltage)

#### CW and Manual Modes

**Accuracy:** Stability  $\times f_c$  time base  
**Resolution:** 1 Hz  
**Switching Time (typical):** 70 ms max.

#### Ramp Sweep Mode

**Accuracy<sup>1,2</sup>:** The greater of  $\pm 0.01\%$  of span  $\pm$  timebase stability  $\times f_c$  or  $\pm 75$  kHz  $\pm$  timebase stability  $\times f_c$   
**Sweep Time:** 10 ms to 100 s; 50 ms for full span  
**Resolution:** 1 kHz

#### Step Sweep Mode

**Accuracy:** Timebase stability  $\times f_c$   
**Number of Points:** 2 to 1601  
**Switching Time (typical)<sup>3</sup>:** 7 ms  $\pm$  8 ms/GHz step

### Output Power Characteristics

#### Maximum Leveled Power<sup>1,4</sup>

**83751A, 83752A:** 10 dBm  
**83751B, 83752B:** 17 dBm (16 dBm < 2 GHz on 83752B)

#### Minimum Settable Power

**83751A, 83752A:** -15 dBm (-85 dBm w/Option 1E1)  
**83751B, 83752B:** -10 dBm (-80 dBm w/Option 1E1)

**Resolution:** 0.01 dB settable

#### Accuracy<sup>1</sup>

**85751A, 83752A only:**  $\pm 1.0$  dB (levels > -10 dBm)  
**83751A/B, 83752A/B:**  $\pm 1.5$  dB (levels > -75 dBm)

#### Flatness

**85751A, 83752A only:**  $\pm 0.7$  dB (levels > -10 dBm)  
**85751A/B, 83752A/B:**  $\pm 1.3$  dB (levels > -75 dBm)

**Power Sweep Range:** 25 dB/sweep

**Power Slope Range:** 0 to  $\pm 2$  dB/GHz, 25 dB max

**Source Match (typical):** < 1.7:1 SWR

### Spectral Purity

#### Harmonics

**83751A, 83752A:** -45 dBc (-30 dBc < 1.5 GHz on HP 83752A)  
**83751B, 83752B:** -20 dBc

**Subharmonics:** None

**Non-Harmonic Spurious<sup>5</sup>:** -50 dBc

**Residual FM:** 1 kHz RHS in CW mode (0.05 to 15 kHz BW)

**Phase Noise (typical):** < -75 dBc/Hz at 10 GHz in CW mode, 10 kHz offset

### Modulation

#### External AM (typical)

**Sensitivity:** 1 dB/V

**3 dB Bandwidth:** > 100 kHz, usable to 1 MHz

#### Depth

**83751A, 83752A:** 20 dB (-10 to +10 dBm)

**83751B, 83752B:** 22 dB (-5 to +17 dBm)

**Input Impedance:** 3.5  $\Omega$

#### External FM (typical)

##### DC/Unlocked Mode

**Rates:** dc to 10 MHz

##### Maximum Deviation

dc to 100 Hz Rates:  $\pm 75$  MHz

100 Hz to 1 MHz Rates:  $\pm 7$  MHz

1 to 2 MHz Rates:  $\pm 5$  MHz

2 to 10 MHz Rates:  $\pm 1$  MHz

##### AC/Locked Mode

**Rates:** 50 kHz to 10 MHz

**Maximum Deviation:** Same as unlocked mode up to 25 x rate

#### Pulse (typical)

**On/Off Ratio:** 60 dB

##### Rise/Fall Times

50 MHz to 2 GHz: 15 ns

2 to 20 GHz: 100 ns rise/50 ns fall

**Minimum Pulse Width:** 2  $\mu$ s

##### Internal Pulse Generation

**Width Range:** 1  $\mu$ s to 65 ms

**Period Range:** 2  $\mu$ s to 65 ms

**Resolution:** 1  $\mu$ s

**Internal Square Wave:** 1 kHz and 27.8 kHz (scalar analyzer mode)

### General

**Bandwidth Points:** 2 GHz, 3.75 GHz, 6.75 GHz, and 11 GHz.

The 3.75 and 6.75 GHz synthesizer switch will disappear if sweep is < 0.8 of an octave in the 2 to 11 GHz band.

**RF Output Connector:** 3.5 mm

**Option 1ED:** Type-N

**Operating Temperature Range:** 0° to 55° C

**Weight:** Net 16 kg (35 lb)

**Size:** 133 H mm x 425 W mm x 483 D mm (5.25 in x 16.75 in x 19 in)

### Key Literature

83751A/B and 83752A/B Synthesized Sweepers

Technical Data, p/n 5091-5908E

### Ordering Information

**83751A** 2 to 20 GHz Synthesized Sweeper

**83751B** 2 to 20 GHz Synthesized Sweeper (High Power)

**83752A** 0.01 to 20 GHz Synthesized Sweeper

**83752B** 0.01 to 20 GHz Synthesized Sweeper (High Power)

The following options apply to all models:

**Opt 1E1** 70 dB Step Attenuator

**Opt 1E4** Rear-Panel RF Output

**Opt 1E5** High-Stability Time Base

**Opt 1ED** Type-N Connector Output

**Opt 1EE** Source Module Interface Connector and Extension Cable

<sup>1</sup> For operating temperatures of 25  $\pm$  5° C.

<sup>2</sup> For 100 ms sweep times; improves with slower sweeps.

<sup>3</sup> Up to 50 ms switching times can occur when crossing the 2 GHz band switch point.

<sup>4</sup> Option 1E1 reduces output power up to 1 dB.

<sup>5</sup> For spurs > 500 kHz from output frequency.



- +20 dBm (83624B) to -110 dBm (Option 001) calibrated output power
- -50 dBc harmonics < 26.5 GHz typical
- SSB phase noise < -80 dBc at 10 GHz and 10 kHz offset
- Complete analog sweeper
- 1 Hz frequency resolution (Option 008)
- Pulse, amplitude and frequency modulation (8360B series only)



The 8360B/L series for the winning combination of precision, versatility and flexibility

### 8360B/L Synthesized Swept Signal and CW Generator Series



The 8360 family consists of the general-purpose B-model series and the L-model (without modulation) series. They combine the excellent frequency resolution, level control, signal purity, and modulation capabilities you expect of a high-performance synthesized signal generator with the speed and convenience of a sweep oscillator. They are ideal for the demanding requirements of signal simulation, local oscillator, and stimulus/response component or subsystem test applications.

The Agilent 8360 family offers a choice of models to meet a variety of application requirements. Ultra-broadband frequency coverage for 10 MHz to 50 GHz is available in coax using a 2.4-mm precision connector. High-power models with up to +20 dBm are also available. The 8360 can also be customized with 1 Hz frequency resolution, fast pulse, a synthesized internal modulation generator and a blank front panel for automated test applications.

### Flexible and Upgradeable for Growth

The 8360 is designed to facilitate future growth. The hardkey and softkey front-panel design offers easily-accessible functions that are simple to use. Softkey flexibility and modular architecture provide upgrade capability, while retaining system compatibility. The family delivers the cost-effective and state-of-the-art performance you need today, while protecting your investment in the future.

### Pulse, Scan, Amplitude, and Frequency Modulation (8360B series only)

High-performance pulse modulators with > 80 dB on/off ratio, and rise/fall times < 10 ns (Option 006), make the 8360B suitable for the most demanding pulse modulation applications.

In addition to its linear AM mode (100%/V), the 8360B offers a scan modulation mode (10 dB/V). Both modes have dc-coupled amplitude modulation capability with a 3 dB bandwidth of 100 kHz, and 99.7% (50 dB) of modulation depth. Pulse and amplitude modulation capabilities can be used independently and simultaneously.

The 8360B also offers dc-coupled frequency modulation capabilities with rates up to 8 MHz.

### Specifications Summary

#### Frequency

Range (by model):

- 83620B 10 MHz to 20 GHz
- 83622B 2 GHz to 20 GHz
- 83623B 10 MHz to 20 GHz (high power)
- 83624B 2 GHz to 20 GHz (high power)
- 83630B 10 MHz to 26.5 GHz
- 83640B 10 MHz to 40 GHz
- 83650B 10 MHz to 50 GHz
- 83623L 10 MHz to 20 GHz
- 83630L 10 MHz to 26.5 GHz
- 83640L 10 MHz to 40 GHz
- 83650L 10 MHz to 50 GHz

Resolution: 1 kHz (1 Hz with Option 008)

### Internal Reference Oscillator

Frequency: 10 MHz

Timebase Stability

Aging Rate:  $5 \times 10^{-10}$  /day;  $1 \times 10^{-7}$  /year

Temperature Effects:  $1 \times 10^{-10}$  /°C

Line Voltage Effects:  $5 \times 10^{-10}$  (10° C change in voltage)

### CW and Manual Modes

Accuracy: Timebase stability  $\times f_c$

Switching Time

For Steps Within a Frequency Band: 15 ms + 5 ms/GHz step size

Maximum, or Across Band Switch Points: 50 ms

Step or List Modes Within a Frequency Band: 5 ms + 5 ms/GHz step size

### Step Sweep Mode

Accuracy: Timebase stability  $\times f_c$

Minimum Step Size: Same as frequency resolution

Number of Points: 2 to 801

Switching Time: Same as CW

Dwell Time: 100  $\mu$ s to 3.2 s

### List Mode

Accuracy: Timebase stability  $\times f_c$

Minimum Step Size: Same as frequency resolution

Number of Points: 1 to 801

Switching Time: Same as CW

Dwell Time: 100  $\mu$ s to 3.2 s

### Ramp Sweep Mode

Accuracy: (Sweep time  $\geq$  100 ms and  $\leq$  5 s)

Sweep Widths > n x 10 MHz: Lesser of 1% of sweep width or n x 1 MHz + 0.1% of sweep width

Sweep Time: 10 ms to 100 s, 300 MHz/ms maximum rate

### Output

#### Output Power

Maximum Levelled (dBm)	Standard	Option 006 (B models only)
83620B, 83622B	+13	+13
83623B	+17	+17
83623L	+15	N/A
83624B	+20	+17
83630B/L		
Output Frequencies < 20 GHz	+13	+13
Output Frequencies $\geq$ 20 GHz	+10	+10
83640B/L		
Output Frequencies < 26.5 GHz	+10	+10
Output Frequencies $\geq$ 26.5 GHz	+6	+6
83650B/L		
Output Frequencies < 26.5 GHz	+10	+10
Output Frequencies $\geq$ 26.5 GHz and < 40 GHz	+5	+5
Output Frequencies $\geq$ 40 GHz	+2.5	+2.5

#### Minimum Settable Output Power

Standard: -20 dBm

Option 001: -110 dBm

Resolution: 0.02 dB

#### Output Connector

Nominal output impedance 50 ohms (precision 3.5-mm male on 20 and 26.5 GHz models, 2.4-mm male on 40 and 50 GHz models, front panel)

8360B  
Series  
8360L  
Series

### Spectral Purity

#### Spurious Signals (dBc)

Output Frequencies	83620B 83622B	83623B 83624B	83623L	83630B/L	83640B/L 83650B/L
<b>Harmonics</b>					
<b>&lt; 2.0 GHz</b>					
Standard	-30	-25 <sup>1</sup>	-25 <sup>1</sup>	-30	-30 <sup>1</sup>
Option 006	-30 <sup>1</sup>	-25 <sup>1</sup>	—	-30 <sup>1</sup>	-30 <sup>1</sup>
<b>≥ 2.0 GHz and &lt; 26.5 GHz</b>					
Standard	-50	-25	-45	-50	-50
Option 006	-60	-60	—	-60	-50
<b>≥ 26.5 GHz</b>					
Standard	—	—	—	—	-40
Option 006	—	—	—	—	-40
<b>Subharmonics</b>					
<b>&lt; 7 GHz</b>					
Standard	None	None	None	None	None
<b>≥ 7 and ≤ 20 GHz</b>					
Standard	-50	-50	-50	-50	-50
<b>≥ 20 GHz and ≤ 40 GHz</b>					
Standard	—	—	—	-50	-40 <sup>2</sup>
<b>&gt; 40 GHz</b>					
Standard	—	—	—	—	-35 <sup>2</sup>

<sup>1</sup> Specification is -20 dBc below 50 MHz.

<sup>2</sup> Specifications typical below 0 dBm.

#### Nonharmonically Related

- 10 MHz to < 2.0 GHz<sup>3</sup>: -60
- ≥ 2.0 to < 20 GHz: -60
- > 20 GHz to ≤ 26.5 GHz: -58
- > 26.5 to ≤ 40 GHz: -54
- ≥ 40 GHz to ≤ 50 GHz: -52

#### Single-Sideband Phase Noise (dBc/Hz)

Frequency Range	Offset from Carrier			
	100 Hz	1 kHz	10 kHz	100 kHz
10 MHz to < 7 GHz	-70	-78	-86	-107
7 GHz to < 13.5 GHz	-64	-72	-80	-101
13.5 GHz to 20 GHz	-60	-68	-76	-97
> 20 GHz to < 26.5 GHz	-58	-66	-74	-95
26.5 GHz to < 38 GHz <sup>4</sup>	-54	-62	-70	-91
38 GHz to 50 GHz	-52	-60	-68	-89

### Modulation (8360B series only)

All modulation specifications are only applicable to the 8360B series. Pulse modulation specifications apply for output frequencies 400 MHz and above.

Pulse (8360B only)	Standard	Option 006
<b>On/Off Ratio</b>	80 dB	80 dB
<b>Rise/Fall Times</b>	25 ns	10 ns
<b>Minimum Width</b>		
Internally Levelled	1 μs	1 μs
<b>Search Mode</b>		
Output Frequencies < 2.0 GHz	50 ns	50 ns
Output Frequencies ≥ 2.0 GHz	50 ns	15 ns
<b>ALC Off Mode</b>		
Output Frequencies < 2.0 GHz <sup>5</sup>	50 ns	50 ns
Output Frequencies ≥ 2.0 GHz	50 ns	15 ns

#### AM and Scan (8360B only)

**Bandwidth** (3 dB, 30% depth, modulation peaks 3 dB below maximum rated power): dc to 100 kHz

#### Modulation Depth

- Normal Mode:** -20 dBm to maximum available power
- Deep Mode:** 50 dB below maximum available power

#### Sensitivity

- Linear:** 100%/volt
- Exponential:** 10 dB/volt

#### FM (8360B only)

##### Locked Mode

- Maximum Deviation:** ± 8 MHz
- Rates** (3 dB bandwidth, 500 kHz deviation): 100 kHz to 8 MHz

<sup>3</sup> Specification applies at output levels 0 dBm and below.

<sup>4</sup> This band is 26.5 GHz to 40 GHz on the 83640A.

<sup>5</sup> Frequency range is 26.5 GHz to 40 GHz on the 83640B/L.

#### Unlocked Mode

##### Maximum Deviation

At rates ≤ 100 Hz: ± 75 MHz

At rates > 100 Hz: ± 8 MHz

**Rates** (3 dB bandwidth, 500 kHz deviation): dc to 8 MHz

**Sensitivity:** 100 kHz, 1 MHz, or 10 MHz/volt, switchable

**Accuracy** (1 MHz rate, 1 MHz deviation): 10%

### Internal Modulation Generator (Option 002)

**AM, FM Modulation Signals** (8360B only)

**Internal Waveforms:** Sine, square, triangle, ramp, noise

#### Rate

##### Range:

Sine: 1 Hz to 1 MHz

Square, triangle, ramp: 1 Hz to 100 kHz

**Resolution:** 1 Hz

#### Depth, deviation

**Range:** Same as the base instrument

**Resolution:** 0.1%

**Accuracy:** Same as the base instrument

#### Pulse (8360B only)

**Modes:** Free-run, gated, triggered, delayed

**Period Range:** 300 ns to 400 ms

**Width Range:** 25 ns to 400 ms

**Resolution:** 25 ns

**Accuracy:** 5 ns

#### Video Delay

**Internal sync pulse:** 0 to 400 ms

**Externally-supplied sync pulse:** 225 ns to 400 ms

#### Weight and Dimensions

**Net Weight:** 27 kg (60 lb)

**Dimensions:** 178 mm H x 425 mm W x 648 mm D (7.0 in x 16.75 in x 25.5 in)

### Key Literature

Brochure, p/n 5964-6793E

Technical Specifications, p/n 5964-6162E

Configuration Guide, p/n 5964-6062E

### Ordering Information

**83620B** 10 MHz to 20 GHz

**83622B** 2 GHz to 20 GHz

**83623B** 10 MHz to 20 GHz (high power)

**83624B** 2 GHz to 20 GHz (high power)

**83630B** 10 MHz to 26.5 GHz

**83640B** 10 MHz to 40 GHz

**83650B** 10 MHz to 50 GHz

**83623L** 10 MHz to 20 GHz

**83630L** 10 MHz to 26.5 GHz

**83640L** 10 MHz to 40 GHz

**83650L** 10 MHz to 50 GHz

The following options apply to all models:

**Opt 001** Adds Step Attenuator

**Opt 002** Adds Internal Modulation Generator (8360B only)

**Opt 004** Rear-Panel RF Output

**Opt 006** Fast-Pulse Modulation (8360B only)

**Opt 008** 1 Hz Frequency Resolution

**Opt 700** MATE System Compatibility

**Opt 806** Rack Slide Kit

**Opt 908** Rack Flange Kit

**Opt 910** Extra Operating and Service Manuals

**Opt 913** Rack Flange Kit

**Opt W30** 3 Years of Customer Return Repair Service

#### Upgrades

Model and frequency upgrades are available. Please contact your Agilent sales representative for details.

#### Dedicated 8510 System Source Models<sup>1</sup>

**83621B** 45 MHz to 20 GHz

**83631B** 45 MHz to 26.5 GHz

**83651B** 45 MHz to 50 GHz

<sup>1</sup> No modulation, no front panel. Price of this option varies for different 8360 series models.

- 252 kHz to 1030 MHz frequency range with optional coverage to 2060 MHz
- 15  $\mu$ s frequency switching
- Standalone control of frequency agility

- Specified performance while fast hopping
- FM rates to 10 MHz, deviations to 20 MHz
- Low spurious and phase noise

8645A

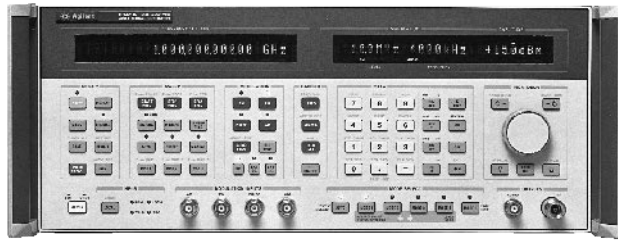

8645A

## 8645A Agile Signal Generator



The Agilent 8645A agile signal generator combines high performance with frequency agility for new fast-switching test requirements. These capabilities are important for performance testing of such devices as frequency agile radios and surveillance receivers. Besides extending traditional receiver testing to agile applications, the 8645A can be used to create complex signal simulations involving several modulation types and frequency agility. These complex RF signals can quantitatively exercise a receiver's vulnerability to a jamming transmission. The 8645A can also be a fast-switching stimulus needed to decrease production test times. The high performance and frequency agility of the 8645A provide capability for both static and agile test requirements with just one calibrated signal generator.

### Specified Agile Performance

The 8645A provides specified signal performance in both static and agile operation. Fully-synthesized outputs with high timebase accuracy are standard when not frequency hopping. The Fast Hop mode activates a frequency-lock loop to allow frequency switching as fast as 15  $\mu$ s from 128 to 2060 MHz. Over the frequency range of 8 to 2060 MHz, the fastest switching time is 85  $\mu$ s and outputs below 8 MHz require 500  $\mu$ sec. Frequency accuracy of each output is better than  $\pm 2$  ppm while in Fast Hop mode. At each frequency, a specific amplitude can be assigned within a 20 dB range for performance tests versus amplitude while frequency hopping. For a full test of a receiver, up to 4000 frequencies can be entered and sequences of up to 8000 frequency settings can be specified. Performance parameters such as phase noise, spurious, amplitude accuracy and modulation remain high-quality and are completely specified while fast hopping to insure confident test results.

### Flexible, High-Performance Modulation

For receiver measurements, the 8645A offers independent or simultaneous FM and AM for both static and hopped frequency tests. The modulating signal can be the internal 0.1 Hz to 400 kHz synthesizer or an external input that allows FM deviations up to 20 MHz at rates up to 10 MHz. In Fast Hop operation, maximum deviation is 3.5 MHz with 10 MHz rates. AM is available with up to 100 kHz rates and 99% depth. Pulse modulation allows a 35 dB on/off ratio with 100 ns rise/fall times.

### Complete Control of Frequency Hopping

The 8645A offers flexible and comprehensive control of the frequency hopping output. Parameters can be entered from the front panel, through the GPIO port or using TTL inputs on the rear panel. Extensive hopped-frequency simulations including hop frequencies, amplitude, dwell times, hop rate, modulation and so forth can be entered into nonvolatile memory from the front panel. Activating a hop sequence requires only a press of the Hop key. Agile control is available by a computer with the added advantage of using the Hewlett-Packard Systems Language (HP-SL). For real-time control, rear-panel inputs accept TTL signals for triggering, dwell time and frequency selection to allow direct connection with the hardware under test. With this wide choice of control, use of the 8645A can be readily customized to a wide variety of test situations from benchtop use to ATE systems.

## 8645A Specifications

### Frequency

**Range:** 251.46485 kHz to 1030 MHz; 251.46485 kHz to 2060 MHz with Option 002 or with 11845A 2 GHz retrofit kit installed

**Frequency Bands:** The exact endpoints of each frequency band can be determined by dividing the 1030 to 2060 MHz band by two for each band decrease. The specifications use approximate endpoints.

**Phase Offset:** Adjustable in 1 degree increments

**Reference Oscillator Stability, Option 001:**  $< 5 \times 10^{-10}$ /day aging

### Fast-Hop Operation

**Frequency Switching Time:** 128 to 1030 MHz:  $< 15 \mu$ s, 8 to 1030 MHz:

$< 85 \mu$ s, 0.25 to 1030 MHz:  $< 500 \mu$ s. Option 002: add 5  $\mu$ s.

**Frequency Hop Range:** 0.25 to 2060 MHz. With FM on, limited to any three consecutive frequency bands.

**Frequency Accuracy<sup>1</sup>:**  $\pm 2$  ppm of carrier frequency

**Amplitude Accuracy:**  $\pm 1$  dB,  $> -127$  dBm output

( $\pm 1.5$  dB,  $> -127$  dBm output when amplitude level is varied up to  $-5$  dB from the constant learned value during Fast Hop)

**Channel and Sequence Tables:** In Fast Hop, each specific frequency and amplitude to be output is entered into a Channel Table. The order of channels to be output is entered into a Sequence Table.

**Maximum Number of Channels:** 4000

**Maximum Number of Channels in Sequence Table:** 8000

**Hop-Rate Range:** Fixed rates from 8 Hz to 50 kHz using internal timer.

An external input allows more range and variable rates.

**Dwell-Time Range:** Fixed times of 6.4  $\mu$ sec to 99 ms using the internal timer. External input allows longer and variable dwell.

**Learn-Cycle Time:** Typically, 10 seconds to 3.5 minutes, depending on sequence size

**Fast-Hop Bus:** Allows real-time selection of any channel for output. Typically, frequency switching time increases by 5  $\mu$ s.

**Modulation:** Internal or external AM, FM, or simultaneous AM/FM

**Output Level:** Allowed amplitude variation of all channels entered is 0 to 20 dB. Output level is reduced by  $> 60$  dB while switching between channels. External dc AM can be used to shape the output.

### Spectral Purity

**SSB Phase Noise (CW, AM, or FM<sup>2</sup> operation):**

Carrier frequency (MHz)	Standard operation		
	20 kHz (dBc/Hz)	100 kHz (dBc/Hz)	Fast Hop 20 kHz (dBc/Hz)
1030 to 2060	-120	-127	-116
515 to 1030	-127	-134	-123
257 to 515	-132	-137	-128
128 to 257	-136	-140	-133
64 to 128	-139	-141	-137
32 to 64	-141	-141	-139
16 to 32	-142	-142	-141
8 to 16	-143	-143	-142
4 to 8	-144	-144	-143
Less than 4 MHz	-144	-144	-144

**Harmonics:**  $< -30$  dBc, output  $\leq 10$  dBm. Option 002, output  $> 8$  dBm:  $< -30$  dBc, 0.25 to 1030 MHz;  $< -25$  dBc, 1030 to 2060 MHz.

**Subharmonics:** None,  $< 515$  MHz;  $< -60$  dBc, 515 to 1030 MHz;  $< -40$  dBc,  $> 1030$  to 2060 MHz

**Nonharmonics:**  $> 20$  kHz offset<sup>3</sup>:  $< -100$  dBc,  $< 1030$  MHz;  $< -94$  dBc,  $> 1030$  to 2060 MHz

<sup>1</sup>Typically,  $+ 2$  ppm of carrier frequency multiplied by the temperature change in  $^{\circ}$ C must be added if ambient temperature changes occur between the learn operation and the conclusion of frequency hopping. FM at minimum deviation.

<sup>2</sup>FM at minimum deviation.

<sup>3</sup>Typically, nonharmonic spurs at all offsets are  $< 30$  dB above the instrument's phase noise level as measured in a 1 Hz bandwidth.

**Residual FM<sup>1</sup>** (CW, AM, FM<sup>2</sup> operation):

Carrier Frequency (MHz)	Post Detection Bandwidth	
	0.3 to 3 kHz (Hz rms)	0.05 to 15 kHz (Hz rms)
0.25 to 257	< 1	< 1.2
257 to 515	< 1.2	< 2
515 to 1030	< 2	< 4
1030 to 2060	< 4	< 8

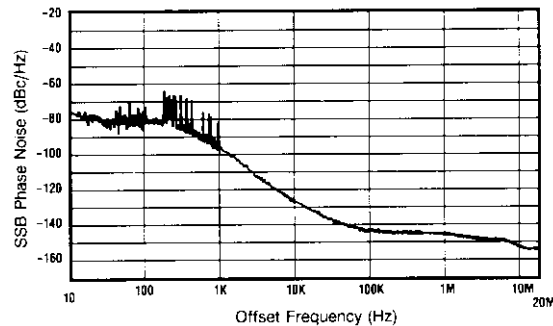
**Typical SSB Phase Noise and Spurs at 1 GHz:**

**Residual AM:** < 0.01% AM rms, 0.3 to 3 kHz post detection BW  
**Typical SSB AM Noise Floor, Offsets > 100 kHz:** < -157 dBc/Hz at +16 dBm output, 0.25 to 1030 MHz. < -150 dBc/Hz at +13 dBm output, 1030 to 2060 MHz.

**Output**

**Maximum Level:** +16 dBm, 0.25 to 1030 MHz; Option 002: +14 dBm, 0.25 to 1030 MHz. +13 dBm, above 1030 MHz.

**Minimum Level:** -137 dBm

**Absolute Accuracy:** ± 1 dB, output ≥ -127 dBm

**Reverse Power Protection:** 50 watts from a 50 Ω source, 25 Vdc

**Typical Third Order Intermodulation:** < -50 dBc, outputs < 8 dBm

**Typical Output Level Overrange:** 2 dB more than maximum level

**Typical SWR and Output Impedance:** < 1.7:1 at < -2 dBm; 50 Ω

**Modulation**

**External Modulation Input:** Coupling is ac or dc for AM, FM, and phase modulation. Pulse modulation input is dc coupled. Displayed deviation or depth corresponds to ± 1 V external input.

**Simultaneous Modulation:** AM/FM, AM/Phase, AM/Pulse, FM/Pulse, Phase/Pulse, AM/FM/Pulse, AM/Phase/Pulse

**Simultaneous Internal/External Modulation:** FM and Phase

**Amplitude Modulation**

**Depth:** 0 to 99.9%, for output < ± 7 dBm

**AM Indicator Accuracy:** ± (6% of setting + 2%, AM), up to 90% depth and 1 kHz rate for carrier frequencies > 1 MHz. When amplitude level is varied up to -5 dB from the constant learned value during Fast Hop: ± (7% of setting + 1% AM) up to 80% depth, 1 kHz rate.

**Distortion, at 400 Hz and 1 kHz Rates:**

Depth	Carrier Frequency	
	0.25 to 1030 MHz	1030 to 2060 MHz
0 to 30%	< 2%	< 5%
30 to 70%	< 3%	< 5%
70 to 90%	< 5%	< 8%

**3 dB Bandwidth<sup>3</sup>:** > 5 kHz, 0.25 to 8 MHz. > 50 kHz, 8 to 128 MHz; > 100 kHz, 128 to 2060 MHz

**Incidental Phase Modulation:** < 0.2 rad peak, at 30% depth and 1 kHz

**Typical External Input Impedance:** 600 Ω

**Frequency Modulation**

**FM Deviation and Rate:** In the highest frequency band of 1030 to 2060 MHz, the maximum FM peak deviation is 20 MHz for standard operation and 3.52 MHz for Fast Hop. Maximum FM rate (3 dB bandwidth) in the 515 to 1030 MHz band and above is 10 MHz. Divide rate and deviation by two for each frequency band decrease.

**FM Indicator Accuracy:** ± 10%, < 50 kHz rate and < 10% of maximum deviation (< 50% of maximum deviation in Fast Hop)

**FM Distortion:** Rates 20 Hz to 100 kHz: < 2.7%, deviation < 2% of maximum available (Fast Hop: < 10% of maximum deviation)

**Carrier Frequency Accuracy in FM:** ± 0.4% of deviation setting, ac- or dc-coupled. Typically add 1% of deviation in Fast Hop.  
**Incidental AM:** < 0.5%, deviation limited to < 6% of max. or 20 kHz  
**Typical External FM Group Delay:** 30 μs for rates 20 Hz to 20 kHz, decreases to < 1 μs at rates > 200 kHz. Fast Hop: < 1 μs.  
**Typical External FM Input Impedance:** 50 or 600 Ω

**Pulse Modulation**

**On/Off Ratio:** > 35 dB

**Rise/Fall Time:** < 100 ns, between 10% and 90% response points

**Maximum Pulse Repetition Frequency:** 1 MHz

**Minimum Pulse Width:** 0.5 μs

**Typical Output Level Accuracy:** ± 2 dB

**Typical External Input Levels and Impedance:** On: > 3.0 V peak; Off: < 0.8 V peak. Damage level: ≥ ± 10 V peak. 600 Ω.

**Internal Modulation Source**

**Waveforms:** Sine, square, sawtooth, and white Gaussian noise

**Frequency Range:** Sine, white Gaussian noise: 0.1 Hz to 400 kHz.

Square, sawtooth: 0.1 Hz to 50 kHz.

**Frequency Accuracy:** Same as internal reference oscillator

**Output Level:** Typically, 1 V<sub>pk</sub> max. into 600 Ω. Accuracy: ± 20 mV.

**Output Level Resolution:** 2 mV. Typical impedance: 600 Ω.

**Distortion:** < 0.1%, output at 1 V peak and ≤ 15 kHz

**Frequency Sweep**

**Phase Continuous Sweep:** Linear sweep with times from 10 ms to 10 s, not dependent on span. Maximum span is 40 MHz from 1030 to 2060 MHz frequency band, divided by two for each band decrease.

**Fast Hop Sweep:** Linear or log stepped with times from 10 ms to 100 s.

Number of steps varies with time selected. Typical time per step is 30 μs for outputs within 128 to 2060 MHz, 170 μs for 8 to 2060 MHz, and 650 μs for 0.25 to 2060 MHz.

**Sweep Control and Markers:** X-axis: 0 to +10 V. Z-axis: +5 V retrace, +1 V trace, 0 V markers. Three markers available.

**General**

**Remote Control:** GPIB (IEEE-488.2-1987). The control language used is the Hewlett-Packard Systems Language (HP-SL). All front-panel functions except power switch and knob. A unique Fast Hop bus interface accepts TTL levels for frequency agile control.

**Operating Temperature Range:** 0° F to +55° F

**Leakage:** Meets MIL-STD-461B-RE02 and FTZ 1046

**Storage Registers:** 10 full function and 40 freq./ampl. locations

**Memory Erasure:** All memory contents according to MIL-STD-380-380

**Size:** 177 mm H x 426 mm W x 624 mm D (7 in x 16.8 in x 24.6 in)

**Weight:** Net, 31 kg (69 lb); shipping, 42 kg (95 lb)

**Key Literature**

8645A Agile Signal Generator Data Sheet, p/n 5953-8498E

8645-1 Communications-Agile Operation of the 8645A Product Note, p/n 5951-6711

**Ordering Information**

**8645A** Agile Signal Generator<sup>4</sup>

**Opt 001** High-Stability Timebase

**Opt 002** 2 GHz Output

**Opt 003** RF Connectors on Rear Panel Only

**Opt 907** Front Handle Kit (5062-3990)

**Opt 908** Rack Flange Kit (5062-3978)

**Opt 909** Rack Flange Kit with Front Handles (5062-3984)

**Opt 910** Provides an additional operation/calibration manual (08645-90023) and 2 service manuals

**Opt 915** Add Service Manual (08645-90104)

**08645-61116** Service Kit

**9211-2662** Transit Case

**1494-0059** Non-Tilting Rack Slide Kit

<sup>1</sup> Specified for 48 to 63 Hz power line. Typical for 400 Hz power line and Fast Hop operation.

<sup>2</sup> Deviation < 0.1% of maximum available.

<sup>3</sup> Lower 3 dB bandwidth limit is 0 Hz for dc coupling and typically 20 Hz for ac coupling.

<sup>4</sup> GPIB cables not included. For description and price, see page 555.

 Indicates QuickShip availability.





- 26.5 to 110 GHz frequency range
- Leveled high output power
- Can be driven by many Agilent microwave sources
- Source module remountable up to one meter length
- Low entry cost



83558A mm-wave source module. 75GHz to 110 GHz

### 83550 Series Millimeter-Wave Source Modules

The five 83550 series millimeter-wave source modules provide a simple approach to extend the frequency range of 11 to 20 GHz sources to cover 26.5 to 40 GHz (83554A), 33 to 50 GHz (83555A), 40 to 60 GHz (83556A), 50 to 75 GHz (83557A) and 75 to 110 GHz (83558A) bands. The 83550 series source modules offer leveled high output power, full waveguide band frequency coverage and the high-frequency accuracy and resolution of the driving microwave source.

As shown in the figure in the right column, there are two basic ways of configuring a millimeter-wave source to best suit your specific needs. You can choose between an individual synthesized sweeper (83623B/L, 83624B, 83751B, or 83752B) or a combination of an 8349 amplifier and another 8360 B/L series or 8370 series synthesized sweeper.

### AM, FM, and Pulse Modulation

The high-performance pulse modulators of the Agilent synthesized sources offer >80 dB on/off ratio and < 50 ns rise and fall times. Pulse amplitudes are leveled for pulse widths as narrow as 1  $\mu$ s.

The 8360 B-series also feature dc-coupled AM with a 3 dB bandwidth of 250 kHz. Pulse and amplitude modulation can be used to simultaneously simulate antenna scan patterns.

FM rates between 100 kHz and 8 MHz may be applied to the 8360 B-series synthesizer input to achieve deviations up to 16 MHz (83554A) and 24 MHz (83555A, 83556A), 32 MHz (83557A), and 48 MHz (83558A) at millimeter-wave frequencies.

### High-Output Power

Leveled-output power from the source modules is rated at +8 dBm for the 83554A, +3 dBm for the 83555A, +3 dBm for the 83556A, +3 dBm for the 83557A, and 0 dBm for the 83558A. This high-output power can permit the source module to serve as a mixer LO in some applications and also expands the available dynamic range in frequency response measurements.

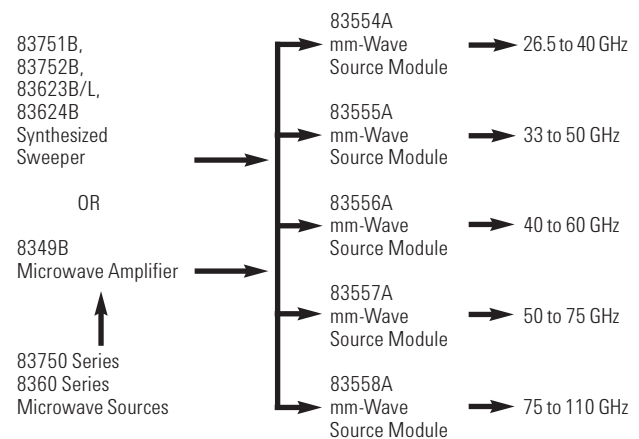

### All at a Lower Cost

The 83550 series source modules combine performance and quality with a low cost of entry. This is possible because the source modules are backward-compatible with existing Agilent microwave sources. Thus you can generate a full waveguide band of millimeter-wave frequencies for just the cost of a source module and an 8349B amplifier (where required). Also, the cost of ownership is reduced even further by the two-year warranty on the microcircuits of the 83550 series source modules and the 8349B microwave amplifier.

### 83554A Output Characteristics

	8360 Series/8349B, 83623B/L, 83624B	8370 Series/8349B, 83751B, 83752B
<b>Maximum leveled power</b> (25° ± 5° C)	+ 8 dBm	+ 8 dBm
<b>Minimum settable power</b>	- 5 dBm	- 5 dBm
<b>Power level accuracy</b> <sup>2</sup> (25° ± 5° C)	± 2.00 dB	± 2.00 dB
<b>Power flatness</b> (at max. leveled power)	± 1.50 dB <sup>3</sup>	± 1.50 dB <sup>3</sup>
<b>Source output SWR</b>	< 2.0	< 2.0
<b>Spurious signals</b> <sup>4</sup>		
Harmonically related spurious:		
26.5 to 26.7 GHz	< - 25 dBc	< - 25 dBc
26.7 to 40.0 GHz	< - 40 dBc	< - 20 dBc

<sup>1</sup> All specifications apply to internally leveled operation only.

<sup>2</sup> Specified with respect to 83550A or 8349B power display. Includes power level flatness.

<sup>3</sup> Must have 0.5 V/GHz modification on microwave source.

<sup>4</sup> Expressed in dB relative to the carrier level (dBc).

83554A  
83555A  
83556A  
83557A  
83558A

### 83555A Output Characteristics<sup>1</sup>

	8360 Series/8349B, 83623B/L, 83624B	8370 Series/8349B, 83751B, 83752B
<b>Maximum leveled power</b> (25° ± 5° C)	+3 dBm	+3 dBm
<b>Minimum settable power</b>	-5 dBm	-5 dBm
<b>Power level accuracy</b> <sup>2</sup> (25° ± 5° C)	±2.00 dB	±2.00 dB
<b>Power flatness</b> (at max. leveled power)	±1.50 dB <sup>3</sup>	±1.50 dB <sup>3</sup>
<b>Source output SWR</b>	< 2.0	< 2.0
<b>Spurious signals</b> <sup>4</sup> Harmonically related spurious:		
33.0 to 37.5 GHz	< -20 dBc	< -20 dBc
37.5 to 49.5 GHz	< -40 dBc	< -50 dBc
49.5 to 50.0 GHz	< -20 dBc	< -20 dBc

### 83556A Output Characteristics<sup>1</sup>

	8360 Series/8349B, 83623B/L, 83624B	8370 Series/8349B, 83751B, 83752B
<b>Maximum leveled power</b> (25° ± 5° C)	+3 dBm	+3 dBm
<b>Minimum settable power:</b>	-5 dBm	-5 dBm
<b>Power level accuracy</b> <sup>2</sup> (25° ± 5° C)	±2.25 dB	±2.25 dB
<b>Power flatness</b> (at max. leveled power)	±1.75 dB <sup>3</sup>	±1.75 dB <sup>3</sup>
<b>Source output SWR</b>	< 2.0	< 2.0
<b>Spurious signals</b> <sup>4</sup> Harmonically related spurious:		
40.0 to 45.0 GHz	< -20 dBc	< -20 dBc
45.0 to 60.0 GHz	< -40 dBc	< -50 dBc

### 83557A Output Characteristics

	8360 Series/8349B, 83623B/L, 83624B	8370 Series/8349B, 83751B, 83752B
<b>Maximum leveled power</b> (25° ± 5° C)	+3 dBm	+3 dBm
<b>Minimum settable power</b>	-2 dBm	-2 dBm
<b>Power level accuracy</b> (25° ± 5° C)	±2.0 dB	±2.5 dB
<b>Power flatness</b> (at max. leveled power)	±1.5 dB	±2.0 dB
<b>Source output SWR</b>		
Leveled:	< 2.0	< 2.0
Unleveled:	< 3.0	< 3.0
<b>Spurious signals</b> <sup>4</sup> Harmonically related spurious:	< -20 dBc	< -20 dBc

### 83558A Output Characteristics

	8360 Series/8349B, 83623B/L, 83624B	8370 Series/8349B, 83751B, 83752B
<b>Maximum leveled power</b> (25° ± 5° C)	0 dBm	0 dBm
<b>Minimum settable power</b>	-5 dBm	-5 dBm
<b>Power level accuracy</b> (25° ± 5° C)	±2.0 dB	±2.5 dB
<b>Power flatness</b> (at max. leveled power)	±1.5 dB	±2.0 dB
<b>Source output SWR</b>		
Leveled:	< 2.0	< 2.0
Unleveled:	< 3.0	< 3.0
<b>Spurious signals</b> <sup>4</sup> Harmonically related spurious:	< -20 dBc	< -20 dBc

<sup>1</sup> All specifications apply to internally leveled operation only.

<sup>2</sup> Specified with respect to 83550A or 8349B power display.  
Includes power level flatness.

<sup>3</sup> Must have 0.5 V/GHz modification on microwave source.

<sup>4</sup> Expressed in dB relative to the carrier level (dBc).

## General Specifications

### Waveguide Output Connector

- 83554A:** EIA size WR 28 waveguide; JAN UG-599 flange
- 83555A:** EIA size WR 22 waveguide; JAN UG-383 flange
- 83556A:** EIA size WR 19 waveguide; JAN UG-383 (mod.) flange
- 83557A:** EIA Size WR 15 waveguide; JAN UG-385 flange
- 83558A:** EIA Size WR 10 waveguide; JAN UG-387 flange

**Weight:** Net, 1.7 kg (4 lb)

**Size:** Module, 80 mm H x 80 mm W x 210 mm D (3.15 in x 3.15 in x 8.27 in)

**Furnished with Each Source Module:** Operating and Service Manual, Modification Procedures for 0.5 V/GHz Output, Type-N RF Cable, Module Base Assembly, Synthesizer Interface Cable

## Key Literature

83557A/83558A Data Sheet, p/n 5958-0398  
83554A/83555A/83556A, MM-Wave Source Modules Data Sheet,  
p/n 5954-8364D

## Ordering Information

- 83554A** 26.5 to 40.0 GHz mm-Wave Source Module
- 83555A** 33.0 to 50.0 GHz mm-Wave Source Module
- 83556A** 40.0 to 60.0 GHz mm-Wave Source Module
- 83557A** 50.0 to 75.0 GHz mm-Wave Source Module
- 83558A** 75.0 to 110.0 GHz mm-Wave Source Module
- Opt 910** Extra Service Manual
- Opt W30** Extended Repair Service (see page 70)  
83554/5/6  
83557/8
- Opt W32** Calibration Service (see page 70)  
83554/5/6  
83557/8



Agilent Technologies offers a complete line of signal analyzers to provide frequency-, time-, order-, angle-, and modulation-domain measurement capability. This section is devoted primarily to the frequency domain. It includes spectrum analyzers, distortion analyzers, audio analyzers, modulation analyzers, and measuring receivers. Each type of instrument has distinctive capabilities that make it the preferred instrument for a particular measurement application.

The spectrum analyzer is a swept-tuned, superheterodyne receiver that provides a display of amplitude versus frequency. It is essentially a frequency-selective, peak-responding voltmeter calibrated to display the rms value of a sine wave. The spectrum analyzer can show the individual frequency components that make up a complex signal. (It does not provide phase information about a signal, however.) The swept receiver technique used in Agilent spectrum analyzers enables frequency-domain measurements to be made over a large dynamic range and a wide frequency range (30 Hz to 325 GHz).

The Fourier analyzer uses digital sampling and mathematical transformation techniques to form a Fourier spectrum of a signal. This method is useful for measuring signals from a few  $\mu\text{Hz}$  to 100 kHz, and provides frequency, amplitude, and phase information. With its real-time signal analysis capability, the Fourier analyzer is able to capture periodic as well as random transient events.

Distortion analyzers and audio analyzers employ broadband detectors and notch filters to measure signal properties such as total harmonic distortion. These tunable filters enable the analyzer to selectively display the level and frequency of harmonic and distortion products. Measurement results are shown on a meter or digital display. Audio analyzers include a signal source, making possible measurements such as SINAD, which include signal and distortion levels. The frequency range covered by Agilent distortion and audio analyzers extends from 5 Hz to 600 kHz.

Modulation analyzers and measuring receivers are designed to capture and analyze a fundamental signal and its entire modulation envelope. Modulation analyzers use independent AM and FM detection circuits for simultaneous analysis of complex modulated signals. When these analyzers are combined with a downconverter and local oscillator, accurate measurements of frequency, power and modulation characteristics can be made on signals from 150 kHz to 26.5 GHz. All measurement results are presented on a digital display.

## Spectrum Analyzers

Spectrum analyzers take advantage of the frequency-conversion properties of the swept-tuned heterodyne receiver to make significant contributions to frequency-domain signal analysis. The following are some of the measurements that can be made with spectrum analyzers:

- Absolute and relative frequency
- Absolute and relative amplitude
- Scalar
- Noise
- Distortion products
- AM, FM, pulsed RF, and digital modulation
- Stimulus response
- Electromagnetic compatibility (EMC)

These measurements are possible because spectrum analyzers have the following characteristics:

- Broad frequency coverage from 30 Hz to 325 GHz
- Wide amplitude range from  $-156$  dBm to  $+30$  dBm
- Tracking generators for scalar measurements
- Excellent sensitivity for low signal detection
- Excellent frequency stability
- High resolution of frequency and amplitude
- Digital demodulation capability

These capabilities allow spectrum analyzers to provide frequency-domain signal analysis for numerous applications, including the manufacture and maintenance of microwave communication links, radar, telecommunications equipment, CATV systems and broadcast equipment, mobile communication systems, EMI diagnostic testing, component testing, lightwave measurements and signal surveillance.

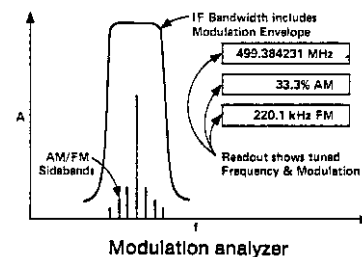
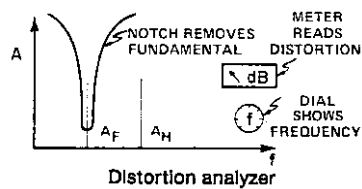
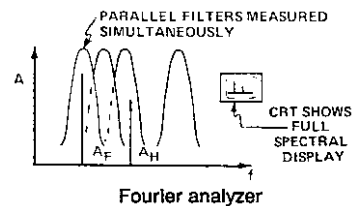
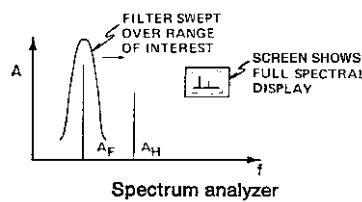
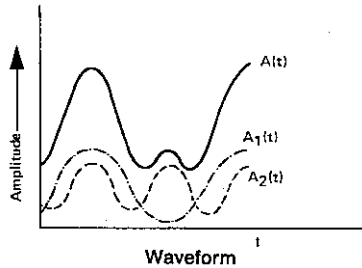

In addition to the swept-tuned frequency mode, spectrum analyzers can also be used in the fixed-tuned mode (zero span) to provide time-domain measurement capability much like that of an oscilloscope.

Vector signal analyzers extend the capabilities available in a spectrum analyzer. Though similar to Fourier analyzers, vector signal analyzers provide capabilities through the RF range, offering fast, high-resolution spectrum measurements, demodula-

tion, and advanced time-domain analysis. They are especially useful for characterizing complex signals such as burst, transient, or modulated signals used in communications, video, broadcast, sonar, and ultrasound imaging applications.

With the addition of computers, the capability of spectrum analyzers can be greatly enhanced. Computers can be used to directly control the operation of spectrum analyzers over GPIB. Computers can also be used to develop downloadable programs (DLPs) for spectrum analyzers with the capability to store such programs in non-volatile memory. These custom measurement routines are then as easy to use as any of the standard instrument features. Custom measurement "personality" cards are available for many spectrum analyzers.

In addition, spectrum analyzers can directly control a plotter or printer, enabling a hard copy of the display to be made without the use of a computer. Application areas that require accurate, high-speed, repetitive routines, physical separation of the operator and the analyzer, unattended operation or operation by personnel with limited technical skills are all candidates for automation.

Areas that benefit significantly from automated spectrum analysis include:

- EMC testing
- frequency spectrum monitoring
- production testing of RF or microwave components, subsystems, or systems
- remote-site testing

The basic measurement capabilities of the spectrum analyzer, combined with its ability to automate and interface with other GPIB instruments and peripherals, make this instrument ideal for many general-purpose and specialized applications.

## Fourier Analyzers

Fourier analyzers offer fast, high-resolution spectrum and network analysis. Unlike conventional swept analyzers, Fourier-based analyzers can measure dynamic signals because they measure all frequencies simultaneously, not one at a time.

Fourier analyzers characterize signals using digital signal-processing techniques based on the Discrete Fourier Transform. For a complete description of these techniques, see Application Note 243, *The Fundamentals of Signal Analysis*.

Fourier analyzers are especially useful on low-frequency signals (< 100 kHz) or where very fast measurements are desired. They can improve measurement speed from a factor of 10 to 100, and allow accurate measurements on frequencies as low as a few  $\mu$ Hz. Signal components as closely spaced as 20  $\mu$ Hz can be clearly resolved and accurately measured.

Since both the magnitude and phase of each frequency component are measured, the Fourier analyzer can measure the statistical properties of signals, or the joint properties or relationships of two or more signals. Applications include acoustic, modal, vibration, or rotating machine analysis. In addition, various types of modulation can be detected and measured.

Simultaneous measurement of magnitude and phase on two or more channels pro-

vides high-quality network measurements. Transfer functions or frequency response can be easily measured, and the use of band-limited or band-translated random noise as the stimulus allows the entire frequency span of interest to be measured at once. Measurement of the coherence function can provide an indication of the validity of many network measurements.

## Distortion and Audio Analyzers

The Agilent distortion and audio analyzers consist of narrowband rejection filters and broadband detectors. Before the fundamental is rejected, the analyzer first measures the amplitude of the fundamental, all the harmonic components, and the noise. Then the rejection filter is employed to remove the fundamental. The ratio of the two measurements is total harmonic distortion plus noise.

## Audio Analyzers

The audio analyzer performs several basic low-frequency measurements in addition to distortion, making it a general-purpose audio test set. The audio analyzer includes the SINAD function for testing mobile radio receiver sensitivity. It contains a low-distortion audio oscillator for stimulus-response testing in combination with its distortion analyzer. It has a true rms voltmeter and dc voltmeter for accurate measurement of complex waveform levels. Swept ac level and swept distortion measurements can be made using the internal source and rms voltmeter. A reciprocal frequency counter is included that continuously counts the frequency of the input signal.

## True Harmonic Distortion Measurements

Computer-controlled spectrum analyzers provide a rapid means of measuring true harmonic distortion levels. The fundamental and its harmonic components are rapidly measured one at a time, and the distortion is computed and either stored or printed.

## Modulation Analyzers/Measuring Receivers/Vector Signal Analyzers

A modulation analyzer is a precision receiver designed to detect the entire modulation envelope of a signal under test. It can measure and display the carrier characteristics of RF frequency and power, as well as AM, FM and phase modulation characteristics such as AM depth, peak deviation, residual modulation, and various associated ratios. The modulation analyzer faithfully recovers the actual modulation signal for further analysis such as distortion testing.

In addition to having all the capabilities of the modulation analyzer, the measuring receiver can measure power down to -127 dBm. With very high accuracy, it can look at signals up to millimeter-wave frequencies. This makes it ideal for the calibration of signal generators and attenuators.



### Vector Signal Analyzers

The vector signal analyzer is also capable of modulation analysis. Similar to Fourier analyzers, vector signal analyzers extend the capabilities of DSP through the RF range. Since both the magnitude and the phase of signals are captured, vector signal analyzers can provide a broad range of measurements including spectrum, modulation and power on baseband, IF, or RF signals. Vector or I and Q formats can be analyzed in addition to AM, FM and PM formats. Vector signal analyzers are especially useful when a broad range of measurements is required, for example, in the development of digital communication systems.

### Microwave Modulation Analyzers

Most modern microwave communication and radar/EW system designers are turning to the use of complex modulations, which involves the use of quadrature or vector modulation formats such as QPSK or 16 QAM in the case of communication systems or complex, coded formats in the case of radar/EW systems.

In all these receivers, the signal processing is not handled in the traditional one-channel, amplitude-only mode, but instead is demodulated into in-phase and quadrature-phase signals that provide dynamic phase and amplitude information about the modulation of the carrier.

Modulation-domain analyzers represent an extension of Agilent's counter/timer technology. They provide helpful views of the frequency, phase, or timing of a signal versus time. They also provide histograms and statistical analyses, making it easy to quickly analyze large amounts of measurement data. Modulation-domain analyzers allow you to directly view frequency switching and settling of VCOs, PLLs and synthesizers. They also make it easy to analyze complex phase and frequency modulations found in modern communications systems. See page 137 for a complete overview.

### Signal Analyzer Selection Guide

#### Spectrum Analyzers<sup>1</sup>

Frequency range	Frequency accuracy (±) <sup>2</sup>	Resolution bandwidth range	Average noise level (narrowest RBW)	Optimum dynamic range 2nd/3rd order	Amplitude accuracy (±)	Model number	Page
<b>Low frequency</b>							
122 mHz to 102.4 kHz	30 ppm	61 mHz to 1024 Hz	<-140 dBVrms/√Hz	90 dB typical	0.25 dB <sup>3</sup>	35670A	273
dc to 10 MHz	30 Hz	312 μHz to 3 MHz	-170 dBm	75 dB/75 dB	0.7 dB <sup>3</sup>	89410A <sup>4</sup>	262
10 Hz to 500 MHz	0.13 ppm <sup>5</sup>	1 Hz to 1 MHz	<-145 dBm	95 dB/100 dB	0.8 dB <sup>3</sup>	4395A	
dc to 40 MHz	.1 ppm	1 Hz to 3 MHz	-153 dBm/Hz	-70 dBc	±1.5 dB	89610A	
<b>RF (data given for CF = 1 GHz)</b>							
9 kHz to 1.5 GHz	2.0 kHz	1kHz to 5 MHz	-117 dBm	76 dB/83 dB	1.1 dB <sup>6</sup>	E4411B	239
9 kHz to 1.5 GHz	101 Hz	10 Hz to 5 MHz	-151 dBm	85.5 dB/97 dB	1.0 dB <sup>6</sup>	E4401B	232
1 MHz to 1.8 GHz	210 Hz	30 Hz to 3 MHz <sup>4</sup>	≤ -88 dBmV	76 dB/88 dB <sup>4</sup>	1.7 dB <sup>3</sup>	8591C	513
9 kHz to 1.8 GHz	210 Hz <sup>4</sup>	30 Hz to 3 MHz <sup>4</sup>	-130 dBm <sup>6</sup>	77 dB/90 dB <sup>6</sup>	1.7 dB <sup>5,3</sup>	8591E	240
dc to 2.65 GHz	180 Hz	312 μHz to 3 MHz	-185 dBm	75 dB/75 dB	1.1 dB <sup>3</sup>	89441A	262
dc to 2.7 GHz	.1 ppm	1 Hz to 3 MHz	-160 dBm/Hz	-70 dBc	±2 dB	89640A	
2 Hz to 1.8 GHz	130 Hz <sup>4</sup>	1 Hz to 3 MHz <sup>5</sup>	-147 dBm	86 dB/102 dB	1.0 dB <sup>3</sup>	4396B	251
9 kHz to 2.9 GHz	210 Hz <sup>4</sup>	30 Hz to 3 MHz <sup>6</sup>	-127 dBm <sup>6</sup>	78 dB/88 dB <sup>6</sup>	1.7 dB <sup>5,3</sup>	8594E	240
30 Hz to 2.9 GHz + mm	106 Hz	1 Hz to 2 MHz	-145 dBm	88 dB/103 dB	1.85 dB <sup>3</sup>	8560E	246
30 Hz to 2.9 GHz + mm	106 Hz	1 Hz to 2 MHz	-145 dBm	88 dB/103 dB	1.85 dB <sup>3</sup>	8560EC	246
100 Hz to 2.9 GHz	110 Hz	10 Hz to 300 kHz (3 MHz) <sup>5</sup>	-134 dBm (-156 dBm) <sup>5</sup>	82 dB/92 dB	1.5 dB (0.9 dB) <sup>7,3</sup>	71100C/P	251
9 kHz to 3.0 GHz	101 Hz	10 Hz to 5 MHz	-151 dBm	90.5 dB/98 dB	1.0 dB <sup>6</sup>	E4402B	232
9 kHz to 3.0 GHz	2.0 kHz	1 kHz to 5 MHz	-117 dBm	78.5 dB/83 dB	1.1 dB <sup>6</sup>	E4403B	239
7 MHz to 4.0 GHz	180 Hz	100 mHz to 1 MHz	-106 dBm	/108 dB	0.5 dB <sup>6</sup>	E4406A	249
30 Hz to 6.5 GHz + mm	106 Hz	1 Hz to 2 MHz	-145 dBm	88 dB/103 dB	1.85 dB <sup>3</sup>	8561E	247
30 Hz to 6.5 GHz + mm	106 Hz	1 Hz to 2 MHz	-145 dBm	88 dB/103 dB	1.85 dB <sup>3</sup>	8561EC	247
9 kHz to 6.5 GHz	210 Hz <sup>4</sup>	30 Hz to 3 MHz <sup>6</sup>	-125 dBm <sup>6</sup>	77 dB/86 dB <sup>4</sup>	2.2 dB <sup>5,3</sup>	8595E	240
9 kHz to 6.7 GHz	101 Hz	10 Hz to 5 MHz	-150 dBm	90 dB/97 dB	1.0 dB <sup>6</sup>	E4404B	232
<b>Microwave</b>							
9 kHz to 12.8 GHz	210 Hz <sup>4</sup>	30 Hz to 3 MHz <sup>4</sup>	-125 dBm	77 dB/86 dB <sup>4</sup>	2.7 dB <sup>3,5</sup>	8596E	240
9 kHz to 13.2 GHz	101 Hz	10 Hz to 5 MHz	-150 dBm	90 dB/97 dB	1.0 dB <sup>6</sup>	E4405B	232
30 Hz to 13.2 GHz	103 Hz	1 Hz to 2 MHz	-151 dBm	95 dB/108 dB	2.1 dB <sup>3</sup>	8562E	247
30 Hz to 13.2 GHz	103 Hz	1 Hz to 2 MHz	-151 dBm	95 dB/108 dB	2.1 dB <sup>3</sup>	8562EC	247
30 Hz to 26.5 GHz	103 Hz	1 Hz to 7 MHz	-151 dBm	77 dB/86 dB	±5 dB	E4440A	231
100 Hz to 26.5 GHz + mm	1 kHz	10 Hz to 3 MHz	-137 dBm (-155 dBm) <sup>5</sup>	99 dB/96 dB	2 dB (0.9 dB) <sup>7,3</sup>	71209A/P	251
100 Hz to 22 GHz + mm <sup>4</sup> + lightwave	1 kHz	10 Hz to 3 MHz	-136 dBm (-153 dBm) <sup>5</sup>	96 dB/98 dB	2.5 dB(0.9 dB) <sup>7,3</sup>	71210C/P	251
50 kHz to 22 GHz + mm <sup>6</sup>	1 kHz	10 Hz to 3 MHz	-109 dBm (-135 dBm) <sup>5</sup>	84 dB/91 dB	2 dB (0.9 dB) <sup>7,3</sup>	71200C/P	251
9 kHz to 22 GHz (26.5 GHz) <sup>5</sup>	1.2 kHz <sup>5</sup>	30 Hz to 3 MHz <sup>6</sup>	-117 dBm <sup>6</sup>	103 dB/81 dB <sup>6</sup>	2.7 dB <sup>5,3</sup>	8593E	240
9 kHz to 26.5 GHz + mm (30 Hz to 26.5 GHz) <sup>6</sup>	1 kHz	1 Hz to 2 MHz	-145 dBm	117 dB/102 dB	3 dB <sup>3</sup>	8563E	247
9 kHz to 26.5 GHz + mm (30 Hz to 26.5 GHz) <sup>6</sup>	1 kHz	1 Hz to 2 MHz	-145 dBm	117 dB/102 dB	3 dB <sup>3</sup>	8563EC	247
9 kHz to 26.5 GHz	101 Hz	10 Hz to 5 MHz	-150 dBm	90 dB/97 dB	1.0 dB <sup>6</sup>	E4407B	232
9 kHz to 26.5 GHz	2.0 kHz	1 kHz to 5 MHz	-116 dBm	78 dB/82 dB	1.1 dB <sup>6</sup>	E4408B	239
100 Hz to 40 GHz + mm <sup>6</sup>	1 kHz	10 Hz to 3 MHz	-136 dBm (-155 dBm) <sup>5</sup>	99 dB/96 dB	2 dB (0.9 dB) <sup>7,3</sup>	71209A/P Z40	251
9 kHz to 40 GHz	1 kHz	1 Hz to 2 MHz	-143 dBm	117 dB/100 dB	3 dB <sup>3</sup>	8564E	247
9 kHz to 40 GHz	1 kHz	1 Hz to 2 MHz	-143 dBm	117 dB/100 dB	3 dB <sup>3</sup>	8564EC	247
9 kHz to 50 GHz	1 kHz	1 Hz to 2 MHz	-143 dBm	117 dB/100 dB	3 dB <sup>3</sup>	8565E	247
9 kHz to 50 GHz	1 kHz	1 Hz to 2 MHz	-143 dBm	117 dB/100 dB	3 dB <sup>3</sup>	8565EC	247

<sup>1</sup> Data shown here is for comparison purposes only. Consult data sheets for more complete specifications.

<sup>2</sup> Accuracy includes 1-year aging. Settability and temperature drift not included.

<sup>3</sup> Relative accuracy consists of relative frequency response plus the lesser of either scale fidelity or IF gain accuracy.

<sup>4</sup> Combination vector-network and spectrum analyzer.

<sup>5</sup> Based on IF gain accuracy specified over 60 dB range. 0 to -50 dBm input signal; span ≤20 kHz; 20° C to 30° C.

<sup>6</sup> Includes optional performance.

<sup>7</sup> Transfer accuracy using 70100A-H01 power meter.

<sup>8</sup> For reference levels 0 to -50 dBm; input attenuation 10dB; RBW=1 kHz; VBW=1kHz; log scale; 0 to 50 dB log range from reference level; coupled sweep time; sample detector;

# Signal Analyzers

230

## Signal Analyzer Selection Guide (cont.)

Overview

### Dynamic Signal Analyzers

Frequency range	Channel match	Frequency resolution in lines	Real-time bandwidth*	Dynamic range	Amplitude** accuracy (+)	Model number	Page
0.000122 Hz to 102.4 kHz	± 0.04 dB, ± 0.5°	100 to 1600	25.6 kHz	80 dB, 90 dB typ.	0.15 dB	35670A	535
dc to 4 MHz	NA	51 to 12,800	1 MHz	80 to 110 dBFS	0.03 dB	3587S	339
0.0002 Hz to 10 MHz	± 0.25 dB, ± 2.0°	51 to 3201	78.125 kHz (1 ch.)	75 dB, 85 dB typ.	0.5 dB	89410A	262

\*One-year aging; settability and temperature drift included.

\*\*Relative accuracy = relative frequency response + lesser of either scale fidelity or IF gain accuracy.

### Distortion/Audio Analyzers

Fundamental frequency range	Minimum distortion	Auto set level	Auto nulling	True RMS	AM detector	Filters	Internal source	GPIB	Model number	Page
20 Hz to 100 kHz	0.01% (-80 dB)	•	•	•	See Note	•	•	•	8903B*	391

\*The 8903B also performs frequency count, signal/noise, SINAD, watts and ac/dc voltage measurements.

### Modulation Analyzers/Measuring Receivers/Vector Signal Analyzers

Frequency range	Modulation measurements	Amplitude measurement range	Audio frequency count + distortion measurement	Model number	Page
150 kHz to 1300 MHz	AM, FM, $\Theta$ M	+30 to -20 dBm	Yes	8901B	257
150 kHz to 1300 MHz	AM, FM, $\Theta$ M	+30 to -127 dBm	Yes	8902A	255
150 kHz to 18 GHz or 26.5 GHz	AM, FM, $\Theta$ M	+30 to -100 dBm	Yes	8902S	309
dc to 2650 MHz	Baseband, IF, RF, I, Q, mag/phase, AM, FM, $\Theta$ M	+25 to -160 dBm	No	89441A	262
dc to 2.7 GHz	Baseband, IF, RF, mag/phase, AM, FM, PM	+20 to -160 dBm	No	89640A	260

\*50 to 200 MHz standard. Operation above 200 MHz available as specials.

### Modulation Domain Analyzers

Frequency range	Resolution freq./time	Sample rate	Memory size	Analysis and displays	Model number	Page
10 Hz to 200 MHz (2.5 GHz option)	10 digits/200 ps	2.5 M (8 M rep.)	8 K (32 K option)	Frequency and time interval vs. time, histograms, statistics (digital RF communications option)	53310A	135
50 Hz to 150 MHz	10 digits/100 ps	80 M	512 K	Frequency, time interval, time stamp, histograms, statistics (application specific software solutions available)	E1740A (VXI)	135

### VCO/PPL Signal Test System

Frequency range	Maximum sensitivity (depends on offset frequency)	Functions available	Model number	Page
10 MHz to 12.6 GHz	-147 dBc/Hz @ offset freq. 100 kHz to 10 MHz (as phase noise measurement performance)	Frequency, power level, C/N ratio (phase noise), FMdeviation and dc consumption current	4352S VCO/PLL Signal Test System	343

- Agilent Performance Spectrum Analyzer (PSA)
- 30 Hz to 26.5 GHz frequency range
- 1 msec 3 GHz sweep
- 2 dB step attenuator to optimize dynamic range
- 160 RBW settings
- Large color display
- Disk drive
- Phase noise optimization
- LAN
- State-of-the-art accuracy and linearity

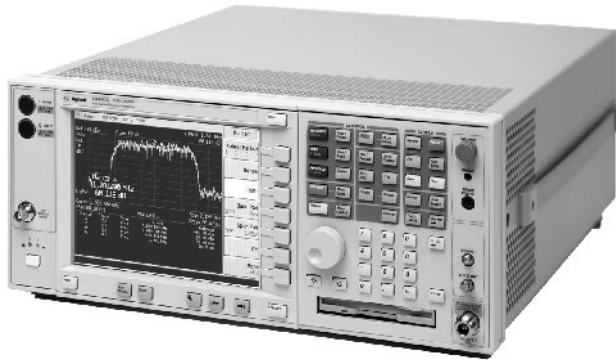

### Agilent Performance Spectrum Analyzers (PSA)

The new Agilent PSA is the first in a series of modern, high performance, signal analysis tools.

The PSA measures and monitors complex RF and microwave signals, providing comprehensive spectrum analysis for communications systems and components. It gives you unprecedented access to new levels of measurement capability with optimized speed, accuracy, and dynamic range for every signal in your system.

#### Measurement Speed

Whether you are tuning oscillators manually or performing high-volume, automatic test on wireless products, the PSA gives a real-time response. These performance spectrum analyzers eliminate your measurement bottlenecks to help you meet your time-to-market goals. The PSA offers state-of-the-art speed in tuning and measurement data transfer.

#### Measurement Accuracy

The greater the measurement accuracy of your spectrum analyzer, the less tolerance is required in your measurement budget, improving product yields.

Amplitude accuracy is made up of several factors: absolute amplitude accuracy, log fidelity, and resolution bandwidth switching error. The PSA has state-of-the-art amplitude specifications.

#### Measurement Resolution

The correct resolution bandwidth for the measurement at hand is critical. A too-narrow resolution means slower sweep speeds than necessary and a too-wide resolution means losing critical signal detail. The PSA has an optional 161 resolution bandwidths (1 Hz to 8 MHz) to choose from, allowing the engineer to optimize for speed or dynamic range.

#### Measurement Dynamic Range

A wide dynamic range allows you to view small signals in the presence of large signals without introducing distortion products. (Dynamic range is defined as the difference between the 1 dB compression point and displayed average noise level.) In order to take advantage of the PSA's excellent dynamic range, an optional 2 dB step attenuator is offered.

#### Measurement Sensitivity

The excellent sensitivity means faster spur searches and signal identification because wider bandwidths can be used. You can improve the noise floor even further with the optional preamplifier.

#### Key Literature

E4440A Performance Spectrum Analyzer Brochure, p/n 5980-1283E  
E4440A Performance Spectrum Analyzer Specifications, p/n 5980-1284E

For a complete description and specifications of the new Agilent PSA, see our web site: [www.agilent.com/find/psa](http://www.agilent.com/find/psa)

ESA-E Series

- 40 updates/sec measurement speed
- $\pm 1$  dB amplitude accuracy
- Optional 10 Hz resolution bandwidth filter
- 99 dB third order dynamic range
- Field rugged portability
- Six-slot option card cage
- Mid-performance analyzers

### ESA-E Series Spectrum Analyzers

The Agilent ESA-E series general purpose, portable spectrum analyzers offer a wide range of performance, features, and flexibility previously unavailable in this price range. Five models offer frequency ranges starting at 9 kHz and ending between 1.5 GHz and 26.5 GHz.

#### Fast measurement speed

The 1 ms RF sweep time and up to 40 measurements per second gives you virtual real-time measurement response. This means you spend less time testing or tuning circuits. High-speed remote measurements and data transfer of up to 40 measurements per second reduce critical test time in automatic test environments. Optional 50 ns zero-span sweep time illuminates fast changing signals in the time domain.

#### Highly accurate

A continuously phase-locked synthesizer operating over the entire sweep provides improved frequency accuracy, stability, and repeatability. The outstanding amplitude accuracy of  $\pm 1$  dB up to 3 GHz and  $\pm 2.5$  dB up to 26.5 GHz adds measurement confidence, improved yield and reduced test margins. The amplitude correction factor capability lets users remove frequency-related effects.

Automatic background alignment provides continuous calibration between sweeps, which means the full accuracy is maintained without operator intervention.

#### Digital resolving power

With the optional digital resolution bandwidth (RBW) filters (10 Hz to 300 Hz), you obtain finer resolving power to separate and measure closely spaced signals. A narrow shape factor (5:1) aids measurement of small signals close to the carrier. These digital RBW filters sweep up to 220 times faster than their analog equivalents, while improving sensitivity.

#### Wide dynamic range

99 dB maximum 3rd order dynamic range (+12 dBm TOI) and the 5 dB step attenuator let you see low-level distortion. Spur searching is enhanced with the  $-152$  dBm sensitivity, optional built-in pre-amp, and the fast measurement speed. Up to 120 dB of calibrated display range allows simultaneous display of large and small signals.

#### Rugged portability

Take the analyzer's lab grade performance into the field protected by rubber encased frames, rain-resistant front panel, and shielded vents. A snap on battery provides up to 1.9 hours of cordless operation and 12 Vdc capability allows operation with automotive electrical systems. Five-minute warm-up offers full measurement accuracy without waiting. And, automatic background alignment maintains the full measurement accuracy over time and varying temperatures.

#### Flexible platform

The ESA-E series can be configured specifically for your application as well as protect your investment into the future. The six-slot option card cage allows you to choose only the performance you need now and upgrade in the future. This scalable performance in combination with Agilent measurement personalities, downloaded into the internal memory, can transform the analyzer into an application focused solution, for example, cdmaOne or GSM measurements.

A growing number of plug-in option boards provide even more measurement capability. Most option boards are easily installed into the built-in card cage and are retrofittable.

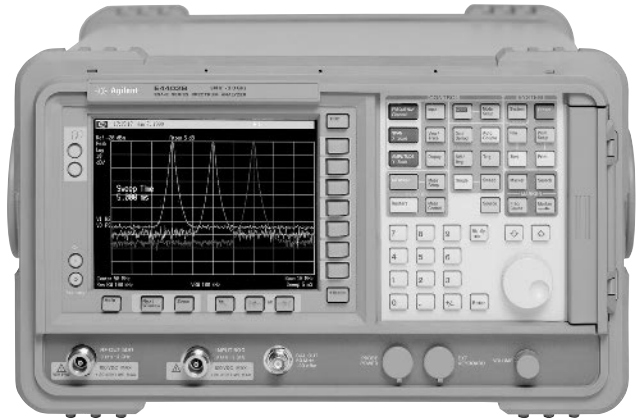

Options include:

- Digital narrow resolution bandwidth filters of 10, 30, 100, 200 EMI and 300 Hz.
- Time-gated spectrum analysis
- FM demodulation/deviation plus tune and listen
- TV trigger with color picture on screen
- 1.5/3.0 GHz built-in tracking generators
- Pre-amplifier (1.5/3.0 GHz fully calibrated)
- 100 Hz low frequency operation
- High stability frequency reference
- Fast time-domain sweeps to 50 ns
- Battery pack/12 VDC operation
- External mixing capability to 325 GHz
- Digital demodulation communication hardware
- 75  $\Omega$  input

#### Features

- Segmented sweep saves measurement and setup time by viewing, in one sweep, only the frequency spans of interest. Paste together up to 32 discontinuous frequency or zero spans in one sweep. Eliminate the need for sweeping through unwanted frequencies and for multiple setups.
- Variable sweep (trace) points, ranging from 101 to 8192 points, optimize measurements for frequency resolution and accuracy versus speed.
- 16.8 cm, high-resolution color display with wide viewing angle make it easy to identify signals of interest.
- Split screen display shows wide spans while zooming in on signals of interest.
- The next generation user interface improves ease-of-use. Built-in help gives immediate assistance without manuals. When manuals are needed they are provided in printed form, on CD-ROM and on the Internet.
- One-button measurements such as ACP, Occupied BW, Emissions BW, channel power, 10 peaks table and harmonic distortion provide faster and more repeatable results.
- Multiple limit lines with margins and pass/fail messages simplify production testing. Built-in frequency counter with 1 Hz resolution precisely measures individual signals.
- 3 year global warranty lowers cost of ownership.

#### PC connectivity

Store up to 200 traces or states or multiple measurement personalities in the expandable user memory. Use the floppy disk drive or BenchLink XL for storing and transferring measurement results to a PC. SCPI remote control language and VXIplug&play drivers enhance remote program development.

BenchLink XL PC software provides easy transfer of ESA measurement trace data directly into MS Excel spreadsheets or screen images into MS Word documents for analysis, archiving, presentations, or printing. Transfer measurement results over GPIB, RS232, or LAN (using two PCs or an E2050A GPIB/LAN adapter). Save and restore analyzer states. Unattended operation with repetitive sequence of measurement transfers by date and time. BenchLink XL is included standard with GPIB and RS232 options.



Combine the ESA-E series optional hardware configurations with downloadable measurement personalities to create application-specific solutions.

### Measurement Personalities

For a growing number of applications Agilent offers unique software programs (provided on 3.5-inch disks) designed specifically for the ESA-E series. Downloaded into analyzer memory, each measurement personality provides measurement setups, routines, and results specific to your application, including a user interface with application related terminology.

- Easy to use, one-button measurements
- Complex algorithms executed with a button press
- Improved accuracy and repeatability
- Operator independent results
- Decreased training time
- Improved productivity

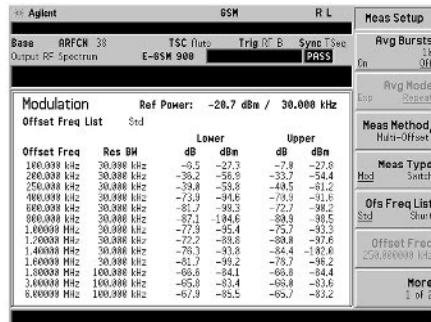

### GSM

Options BAH (measurement personality) and B74 (digital demodulation hardware) combine to provide all the GSM 900, DCS1800, PCS1900 tests required to verify the performance of GSM mobile and BTS transmitters. Measurement features include mean TX power, power ramp, ORFS, phase and frequency error, distance-to-fault, and more. See page 381 for further information.

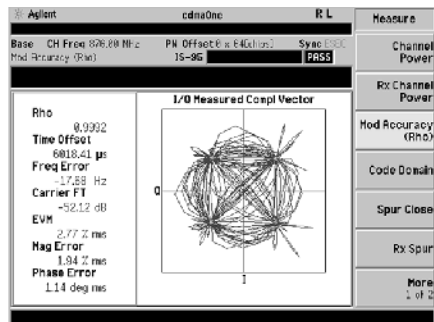

### cdmaOne

Options BAC (measurement personality) and B74 (RF and digital demodulation hardware) combine to make the cdmaOne standard tests required to verify the performance of cdmaOne transmitters. Measurement features include channel power, ACPR, modulation accuracy (RHO), code domain power, occupied bandwidth, in- and out-of-band spurious, and more. See page 381 for further information.

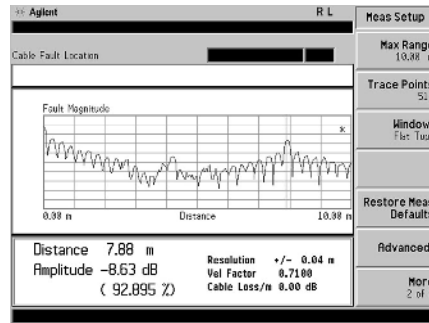

### Cable Fault Location

Options 225 (measurement personality), 1DN (tracking generator), and B7K (measurement kit) combine to identify distance-to-cable discontinuities for fault location and troubleshooting of cable installation and maintenance. Includes table of common cable types with their loss and velocity factors.

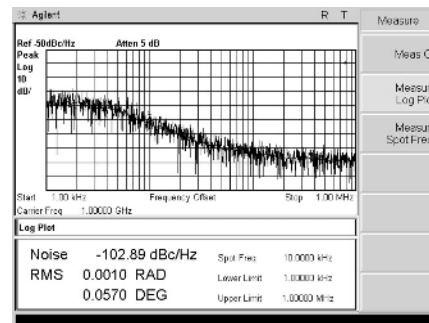

### Phase Noise

Option 226 (measurement personality) provides a log plot of phase noise in dBc/Hz versus offset frequency. Includes spot frequency readout and RMS phase noise integrated over a specified range, displayed in radians and degrees.

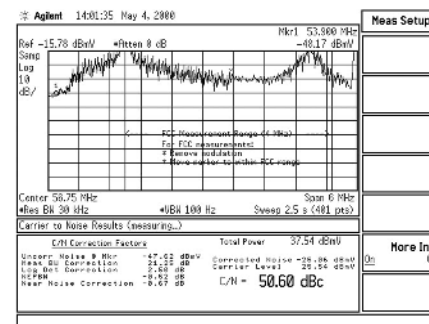

### Cable TV Service and Installation

Option 227 (CATV measurement personality) provides Cable TV operators fast, accurate, and rugged spectrum analysis for field installation, ingress evaluation, and troubleshooting. One-button measurements include video carrier levels and frequencies, carrier-to-noise, CSO/CTB, hum and, with options B7B and BAA, TV trigger and picture on screen.

E4401B  
E4402B  
E4404B  
E4405B  
E4407B



## ESA-E Series

### Specifications

All specifications apply over 0° C to +55° C unless otherwise noted. The analyzer will meet its specifications after 2 hours of storage within the operating temperature range, 5 minutes after the analyzer is turned on, and after ALIGN NOW [RF] has been run.

### Frequency Specifications

#### Frequency Range

<b>E4401B</b>	50 Ω	9 kHz to 1.5 GHz
	75 Ω	1 MHz to 1.5 GHz
<b>E4402B</b>	Option UKB	9 kHz to 3.0 GHz
		100 Hz to 3.0 GHz
<b>E4404B</b>	Band	9 kHz to 3.0 GHz (dc coupled)
	0	100 Hz to 3.0 GHz
	Option UKB	100 Hz to 3.0 GHz (ac coupled)
	0	100 kHz to 3.0 GHz (ac coupled)
	1	2.85 GHz to 6.7 GHz
<b>E4405B</b>	Band	9 kHz to 3.0 GHz (dc coupled)
	0	100 Hz to 3.0 GHz
	Option UKB	100 Hz to 3.0 GHz (ac coupled)
	0	100 kHz to 3.0 GHz (ac coupled)
	1	2.85 GHz to 6.7 GHz
	2	6.2 GHz to 13.2 GHz
<b>E4407B</b>	Band	9 kHz to 3.0 GHz
	0	100 Hz to 3.0 GHz
	Option UKB	100 Hz to 3.0 GHz
	1	2.85 GHz to 6.7 GHz
	2	6.2 GHz to 13.2 GHz
	3	12.8 GHz to 19.2 GHz
	4	18.7 GHz to 26.5 GHz
External Mixing (Opt AYZ)		18 GHz to 325 GHz
<b>Frequency Reference</b>		(Opt.1D5)
Aging	±2 x 10 <sup>-6</sup> /year	±1 x 10 <sup>-7</sup> /year
Temperature Stability	±5 x 10 <sup>-6</sup>	±5 x 10 <sup>-8</sup>
Settability	±5 x 10 <sup>-7</sup>	±1 x 10 <sup>-8</sup>
<b>Frequency Readout</b>		
Accuracy (Start, Stop, Center, Marker)	±(frequency indication x frequency reference error <sup>1</sup> + 0.5% of span + 15% of RBW + 10 Hz + span ÷ sweep points -1)	
<b>Marker Frequency Counter<sup>2</sup></b>		
Accuracy <sup>3</sup>	±(marker frequency x frequency reference error <sup>1</sup> + counter resolution)	
Counter Resolution	Selectable from 1 Hz to 100 kHz	
<b>Frequency Span</b>		
Range	0 Hz (zero span), 100 Hz to the range of the spectrum analyzer	
Resolution	2 Hz x N <sup>4</sup>	
Accuracy (8192 sweep points)	±0.5% of span + 2 x span ÷ sweep points -1	

#### Frequency Sweep Time

Range	1 ms to 4000 s
Span = 0 Hz	10 μs to 4000 s
(Opt. AYX)	50 μs to 4000 s (RBW ≥ 1 kHz)
Accuracy	±1%
Sweep Trigger	Free run, Single, Line, Video, External, Offset, Delay, Gate (Opt.1D6), and TV (Opt. B7B)
Offset trigger range	± 327 ms to ±12.3 μs
Sweep (trace) point range	Span > 0Hz 101 to 8192
	Span = 0Hz 2 to 8192

#### Resolution Bandwidth (RBW)

Range	1 kHz to 5 MHz (-3 dB) in 1-3-10 sequence.
	9 kHz and 120 kHz (-6 dB) EMI bandwidths.
(Opt. 1DR)	Adds 10, 30, 100, and 300 Hz (-3 dB) bandwidths and 200 Hz (-6 dB) EMI bandwidth.

#### Accuracy

1 kHz to 3 MHz RBW	±15%
5 MHz	±30%
10 Hz to 300 Hz RBW	±10%
(Opt. 1DR)	

#### Selectivity (Characteristic) -60 dB/-3 dB

10 Hz to 300 Hz (Opt. 1DR)	<5:1
1 kHz to 5 MHz	<15:1

#### Video Bandwidth

Range	30 Hz to 3 MHz <sup>5</sup> in 1-3-10 sequence
(Opt. 1DR)	Adds 1, 3, 10 Hz for RBW<1kHz

#### Stability Noise sidebands (1 kHz RBW, 30 Hz VBW and sample detector)

≥10 kHz offset from CW signal	≤-90 dBc/Hz + (20 Log N <sup>4</sup> for frequencies >6.7 GHz)
≥20 kHz offset from CW signal	≤-98 dBc/Hz + (20 Log N <sup>4</sup> for frequencies >6.7 GHz)
≥30 kHz offset from CW signal	≤-100 dBc/Hz + (20 Log N <sup>4</sup> for frequencies >6.7 GHz)
≥100 kHz offset from CW signal	≤-112 dBc/Hz + (20 Log N <sup>4</sup> for frequencies >6.7 GHz)

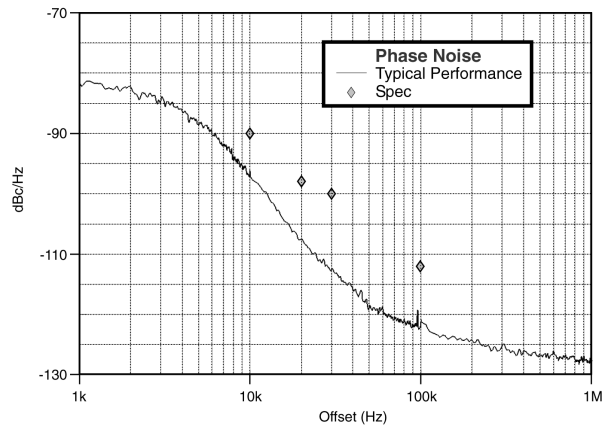

#### Residual FM

1 kHz RBW, 1 kHz VBW	≤150 x N <sup>4</sup> Hz pk-pk in 100 ms
(Opt. 1D5)	≤100 x N <sup>4</sup> Hz pk-pk in 100 ms
(Opt. 1DR, 1DE)	≤2 x N <sup>4</sup> Hz pk-pk in 20 ms

#### System-Related Sidebands (offset from CW signal)

≥30 kHz	≤-65 dBc + (20 Log N <sup>4</sup> for frequencies >6.7 GHz)
---------	---

### Amplitude Specifications

#### Amplitude Range

Measurement Range	Displayed average noise level to maximum safe input level
Input Attenuator range	
E4401B	0 to 60 dB, in 5 dB steps
E4402B/04B/05B/07B	0 to 65 dB, in 5 dB steps

### Maximum Safe Input Level

Average Continuous Power (input attenuator ≥15 dB)  
 E4401B +30 dBm (1 W)  
 E4401B (75 Ω Opt. 1DP) +75 dBmV (0.4 W)  
 E4402B/04B/05B/07B (input attenuator ≥5 dB)  
 +30 dBm (1 W)

Peak Pulse Power (input attenuator ≥15 dB)  
 E4401B +30 dBm (1 W)  
 E4401B (75 Ω Opt. 1DP) +75 dBmV (0.4 W)  
 E4402B/04B/05B/07B (input attenuator ≥30 dB)  
 +50 dBm (100 W)

dc  
 E4401B (75 Ω Opt. 1DP) 100 Vdc  
 E4401B, E4402B 100 Vdc  
 E4404B, E4405B 0 Vdc (dc coupled)  
 50 Vdc (ac coupled)  
 E4407B 0 Vdc

**1 dB Gain Compression** (total power at input mixer<sup>6</sup>)  
 ≥50 MHz 0 dBm  
 ≥6.7 GHz -3 dBm  
 ≥13.2 GHz -5 dBm

### Displayed Average Noise Level (dBm)

(Input terminated, 0 dB attenuation, sample-detector, 30/1 Hz VBW)

	1 kHz RBW	10 Hz RBW (Opt. 1DR)	1 kHz RBW w/ preamp (Opt. 1DS)	10 Hz RBW w/ preamp (Opt. 1DR, 1DS)
<b>E4401B</b>				
400 kHz-10 MHz	≤-115	≤-134	≤-131	≤-150
10 MHz-500 MHz	≤-119	≤-138	≤-135	≤-153
500 MHz-1 GHz	≤-119	≤-138	≤-133	≤-152
1 GHz-1.5 GHz	≤-114	≤-133	≤-131	≤-150
<b>E4402B</b>				
30 Hz-9 kHz (Opt. UKB)	-	≤-85 <sup>5</sup>	-	-
9 kHz-100 kHz	-	≤-105 <sup>5</sup>	-	-
100 kHz-1 MHz	-	≤-131 <sup>5</sup>	-	-
1 MHz-10 MHz	≤-117 <sup>6</sup>	≤-136 <sup>6</sup>	≤-134 <sup>6</sup>	≤-152 <sup>6</sup>
10 MHz-1 GHz	≤-117	≤-136	≤-132 (-133 <sup>14</sup> )	≤-150 (-151 <sup>14</sup> )
1 GHz-2 GHz	≤-116	≤-135	≤-132 (-133 <sup>14</sup> )	≤-151 (-152 <sup>14</sup> )
2 GHz-3 GHz	≤-114	≤-133	≤-129 (-132 <sup>14</sup> )	≤-148 (-151 <sup>14</sup> )
<b>E4404/05/07B</b>				
30 Hz-9 kHz (Opt. UKB)	-	≤-85 <sup>5</sup>	-	-
9 kHz-100 kHz	-	≤-105 <sup>5</sup>	-	-
100 kHz-1 MHz	-	≤-131 <sup>5</sup>	-	-
1 MHz-10 MHz	≤-117 <sup>6</sup>	≤-137 <sup>6</sup>	≤-135 <sup>6</sup>	≤-155 <sup>6</sup>
10 MHz-1 GHz	≤-116	≤-136	≤-131 (-132 <sup>14</sup> )	≤-149 (-150 <sup>14</sup> )
1 GHz-2 GHz	≤-116	≤-136	≤-131 (-132 <sup>14</sup> )	≤-150 (-151 <sup>14</sup> )
2 GHz-3 GHz	≤-112	≤-132	≤-127 (-130 <sup>14</sup> )	≤-146 (-149 <sup>14</sup> )
3 GHz-6 GHz	≤-112	≤-132	-	-
6 GHz-12 GHz	≤-111	≤-131	-	-
12 GHz-22 GHz	≤-107	≤-127	-	-
22 GHz-26.5 GHz	≤-106	≤-126	-	-

### Display Range

Log scale 0.1, 0.2, 0.5 dB/division and 1 to 20 dB/division in 1 dB steps; ten divisions displayed.

RBW ≤300 Hz (Opt. 1DR) 0 to -120 dB from reference level is calibrated

RBW ≥1 kHz 0 to -85 dB from reference level is calibrated

Linear scale 10 divisions  
 Scale units dBm, dBmV, dBμV, Volts, Watts, and Hz

### Marker Readout Resolution

Log scale 0.04 dB  
 Linear scale 0.01% of reference level  
 Fast sweep times for zero span (Opt. AXX)

Log scale 0 to -85 dB from ref. level 0.3 dB  
 Linear scale 0.3% of reference level (10 dB input attenuation)

**Frequency Response** Absolute<sup>7</sup> Relative Flatness<sup>8</sup>

20° C to 30° C (30 Hz <sup>8</sup> ) 100 Hz to 3.0 GHz (Opt. UKB)	±0.5 dB	±0.5 dB
9 kHz to 3.0 GHz	±0.46 dB (±0.14 dB typical)	±0.5 dB
3.0 GHz to 6.7 GHz	±1.5 dB	±1.3 dB
6.7 GHz to 26.5 GHz	±2.0 dB	±1.8 dB

0° C to 55° C (30 Hz <sup>8</sup> ) 100 Hz to 3.0 GHz (Opt. UKB)	±1.0 dB	±1.0 dB
9 kHz to 3.0 GHz	±.76 dB	±1.0 dB
3.0 GHz to 6.7 GHz	±2.5 dB	±1.5 dB
6.7 GHz to 26.5 GHz	±3.0 dB	±2.0 dB

### Input Attenuation Switching Uncertainty at 50 MHz

Attenuation setting	
0 dB to 5 dB	±0.3 dB
10 dB	Reference
15 dB	±0.3 dB
20 to 60 dB (E4401B)	±(0.1 dB + 0.01 x attenuator setting)
20 to 65 dB	±(0.1 dB + 0.01 x attenuator setting)

**Overall Amplitude Accuracy<sup>9</sup>** ±(0.54 dB + Absolute Frequency Response)  
 At Reference Settings<sup>13</sup> ±0.34 dB

**RF Input VSWR** (at tuned frequency) 10 dB atten.

100 kHz to 6.7 GHz ≤1.4:1<sup>6</sup>

### Resolution Bandwidth Switching Uncertainty

(Referenced to 1 kHz RBW, at reference level)  
 10 Hz to 3 MHz RBW ±0.3 dB  
 5 MHz ±0.6 dB

### Reference Level

Range -149.9 dBm to maximum mixer level + attenuator setting  
 Resolution ±0.1 dB for log scale, ±0.12% of reference level for linear scale

Accuracy (reference level attenuator setting)

-10 dBm to -60 dBm ±0.3 dB

-60 dBm to -85 dBm ±0.5 dB

-85 dBm to -90 dBm ±0.7 dB

### Display Scale Fidelity

Log maximum cumulative  
 0 dB to -85 dB ±(0.3 dB + 0.01 x dB from ref. level)  
 0 dB to -98 dB (Opt 1DR) ±(0.3 dB + 0.01 x dB from ref. level)  
 98 dB to -120 dB (Opt 1DR) ±(2 dB + 0.01 x dB from ref. level)<sup>6</sup>

Log incremental accuracy  
 0 dB to -80 dB ±0.4dB/4dB form reference

Linear Accuracy ±2% of reference level

**Linear to Log Switching Uncertainty** ±0.15 dB at reference level

### Log Scale Switching

No error

### Spurious Responses

#### Second Harmonic Distortion

E4401B  
 2 MHz to 750 MHz <-75 dBc for -40 dBm tone at input mixer<sup>5</sup>. (+35 dBm SHI)

E4402/04/05/07B  
 10 MHz to 500 MHz <-65 dBc for -30 dBm tone at input mixer<sup>5</sup>. (+35 dBm SHI)

500 MHz to 1.5 GHz <-75 dBc for -30 dBm tone at input mixer<sup>5</sup>. (+45 dBm SHI)

1.5 GHz to 2.0 GHz <-85 dBc for -10 dBm tone at input mixer<sup>5</sup>. (+75 dBm SHI)

>2.0 GHz <-100 dBc for -10 dBm tone at input mixer<sup>5</sup> (or below displayed average noise level). (+90 dBm SHI)

#### Third Order Intermodulation Distortion

E4401B  
 10 MHz to 1.5 GHz <-80 dBc for two -30 dBm tones at input mixer<sup>5</sup> and >50 kHz separation. (+10 dBm TOL, +15 dBm typical<sup>14</sup>)

E4402B/04B/05B/07B  
 100 MHz to 6.7 GHz <-84 dBc for two -30 dBm tones at input mixer<sup>5</sup> and >50 kHz separation. (+12 dBm TOL, +16 dBm typical<sup>14</sup>)

>6.7 GHz <-75 dBc for two -30 dBm tones at input mixer<sup>5</sup> and >50 kHz separation. (+7.5 dBm TOL, +11 dBm typical<sup>14</sup>)

#### Other Input Related Spurious (in band)

>offset 30 kHz <-65 dBc, for -20 dBm tones at input mixer<sup>5</sup>.

#### Residual Responses (input terminated and 0 dB attenuation)

150 kHz to 6.7 GHz <-90 dBm

E4401B  
 E4402B  
 E4404B  
 E4405B  
 E4407B

ESA-E Series

## General Specifications

### Temperature Range

Operating	0° C to +55° C
Disk Drive	10° C to 40° C
Storage	-40° C to +75° C

### EMI Compatibility

Conducted and radiated interference is in compliance with CISPR Pub. 11/1990 Group 1 Class A

### Audible Noise (ISO 7779)

<40 dBA sound pressure and <4.6 Bels power

### Military Specification

Has been type tested to the environmental specifications of MIL-PRF-28800F class 3.

### Power Requirements

On (Line 1)	
AC Operation	
Voltage, frequency	90 to 132 V rms, 47 to 440 Hz
Power consumption	195 to 250 V rms, 47 to 66 Hz
Standby (Line 0)	<300 W
Power consumption	<5 W

### DC Operation

Voltage	12 to 20 Vdc
Power Consumption	<200 W

### Measurement Speed<sup>6</sup>

	E4401B	E4402B	E4404B, E4405B, E4407B
Local measurement rate <sup>10</sup>	≥50/s	≥45/s	≥40/s
Remote measurement and GPIB transfer rate <sup>11</sup>	≥45/s	≥45/s	≥40/s
RF center frequency tuning time <sup>15</sup>	≤75 ms	≤75 ms	≤75 ms

### Data Storage (nominal)

Internal	200 traces or states
External (Floppy)	200 traces or states

### Downloadable Program Memory

Opt. B72	2 MB available
	10 MB available

### Weight (without options)<sup>6</sup>

E4401B	13.2 kg	(29.1 lb)
E4402B	15.5 kg	(34.2 lb)
E4404B/05B/07B	17.1 kg	(37.7 lb)

### Dimensions

w/o handle	222mm H x 409mm D x 373mm W (8.88 in x 16.36 in x 14.92 in)
w/handle (max.)	222mm H x 516mm D x 408mm W (8.88 in x 20.64 in x 16.32 in)

## Option Specifications

### Option 1DN and 1DQ Tracking Generator

#### Frequency Range

E4401B	
Opt. 1DN, (50 Ω)	9 kHz to 1.5 GHz
Opt. 1DQ, (75 Ω)	1 MHz to 1.5 GHz

#### E4402B/04B/05B/07B

Opt. 1DN, (50 Ω)	9 kHz to 3.0 GHz
Resolution BW Range	1 KHz to 5 MHz

#### Output Level

Range	
E4401B	
Opt. 1DN	0 to -70 dBm
Opt. 1DQ	+42.75 to -27.25 dBmV
E4402B/04B/05B/07B	-2 to -66 dBm

#### Absolute Accuracy (@ 50 MHz)

Opt.1DN (E4401B)	±0.5 dB
Opt.1DN	±0.75 dB
Opt.1DQ (E4401B)	±1.5 dB

#### Dynamic Range

Maximum output power-Displayed Average Noise Level

<sup>1</sup>Frequency reference error = (aging rate x period of time since adjustment + settability + temperature stability).

<sup>2</sup>Not available in RBW <1kHz (Option 1DR)

<sup>3</sup>Marker level to DANL >25dB, Frequency offset = 0 Hz, RBW/Span ≥0.002.

<sup>4</sup>N = LO harmonic mixing mode

<sup>5</sup>Mixer Power Level (dBm) = Input Power (dBm) - Input Attenuator (dB).

<sup>6</sup>Characteristic

<sup>7</sup>Referenced to amplitude at 50 MHz

<sup>8</sup>Reference to midpoint between highest and lowest frequency response deviations.

<sup>9</sup>For reference levels 0 to -50 dBm; RBW, 1 kHz; Video BW, 1 kHz; Scale Log, Log range 0 to -50 dB; Sweep time coupled; Signal input, 0 to -50 dBm; Span, ≤20 kHz; Input attenuation 10 dB, 20° C to 30° C.

## Ordering Information

**E4401B** ESA-E 1.5 GHz Spectrum Analyzer

**E4402B** ESA-E 3.0 GHz Spectrum Analyzer

**E4404B** ESA-E 6.7 GHz Spectrum Analyzer

**E4405B** ESA-E 13.2 GHz Spectrum Analyzer

**E4407B** ESA-E 26.5 GHz Spectrum Analyzer

- Opt 0B0** Delete printed manual set (retains CD-ROM manual)
- Opt 0B1** Add manual set
- Opt 0BV** Component level service documentation
- Opt 0BW** Assembly level service guide and CD-ROM with adjustments
- Opt 1AX** RS-232 and Parallel printer interface (includes RS-232 cable and BenchLink XL software)
- Opt 1CP** Rackmount and handle kit with slides
- Opt 1D5** High stability time base
- Opt 1D6** Time-gated spectrum analysis
- Opt 1D7** 50 Ω/75 Ω matching pad with dc block
- Opt 1DN** 1.5 GHz tracking generator (E4401B only)
- Opt 1DN** 3 GHz tracking generator
- Opt 1DP** 75 Ω input (E4401B only)
- Opt 1DQ** 75 Ω tracking generator (E4401B only)
- Opt 1DR** Narrow resolution bandwidths
- Opt 1DS** 1.5 GHz Preamplifier (E4401B only)
- Opt 1DS** 3.0 GHz Preamplifier
- Opt A4H** GPIB and parallel printer interfaces (includes BenchLink XL software)
- Opt A4J** IF, sweep and video ports
- Opt A5D** 12 Vdc power cable
- Opt AXT** Transit case
- Opt AYT** Grey soft carrying/operating case
- Opt AYU** Yellow soft carrying/operating case
- Opt AYX** Fast zero-span sweeps
- Opt B72** Increases useable memory to 10 MB
- Opt B74** RF/Digital communication hardware
- Opt B75** Performance Bundle (1D5+1DR+1DS) E4401B only
- E4402B, E44044B, E4405B, E4407B
- Opt BAA** FM Demodulation/Deviation
- Opt BAB** APC 3.5mm Connector (E4407B only)
- Opt BAC** cdmaOne Measurement Personality
- Opt BAH** GSM Measurement Personality
- Opt UK6** Commerical Calibration Certificate
- Opt UK9** Front panel cover
- Opt B7B** TV Trigger with color picture on screen (requires Opt. BAA)
- Opt AYZ** External Mixing (E4407B only)
- Opt UKB** 100 Hz Low frequency extension (unavailable in E4401B)
- Opt 042** Custom analyzer backpack (grey)
- Opt 044** Custom analyzer backpack (yellow)
- Opt B7K** Cable fault location measurement kit
- Opt 225** Cable fault location measurement personality
- Opt 226** Phase noise measurement personality
- Opt 227** Cable TV service and installation measurement personality

**E1779A** Battery pack

**N2717A** Performance and Adjustment Software for calibration of ESA Analyzers

**41800A** Active Probe (5 Hz to 500 MHz)

**85024A** Active Probe (300 kHz to 3 GHz)

**11742A** dc blocking capacitor, M-F APC 3.5 mm connector (45 MHz to 26.5 GHz)

**11693A** Limiter, M-F Type N connector (100 MHz to 12.4 GHz)

<sup>10</sup>Factory preset, auto align Off, segmented sweep Off, fixed center frequency, RBW = 1 MHz, sweep points = 101, and spans >10 MHz and ≤600 MHz (>102 MHz and ≤400 MHz E4401B).

<sup>11</sup>Factory preset, display Off, single sweep, markers Off, auto align Off, segmented sweep Off, fixed center frequency, RBW = 1 MHz, sweep points = 101, and span = 20 MHz and stop frequency ≤3 GHz.

<sup>12</sup>In time domain sweeps

<sup>13</sup>Settings are: Reference level -20 dBm (-25 dBm E4401B); input attenuation 10 dB; center frequency 50 MHz; RBW 1 kHz; VBW 1 kHz; span 2 kHz; sweep time coupled, sample detector; signal at reference level.

<sup>14</sup>20° C to 30° C

<sup>15</sup>Factory preset, display Off, markers Off, single sweep, auto align Off, segmented sweep Off, RBW = 1 MHz, sweep points = 101, and span = 20 MHz, stop frequency ≤3 GHz, and center frequency tune step size = 50 MHz.



- Frequency range of 9 kHz to 1.5 GHz, 3.0 GHz, and 26.5 GHz
- $\pm 1.1$  dB absolute amplitude accuracy
- Rugged, portable package follows you from lab, to factory, to field
- $\geq 28$  measurement updates/second to the display,  $>30$  measurement updates/second over GPIB
- Affordable, basic performance



E4403B

## ESA-L Series Spectrum Analyzers

Agilent expands the ESA-L series, our, low-cost, fully synthesized spectrum analyzer to 3.0 and 26.5 GHz. Now get quick and accurate results every time, at an affordable price. It has the performance of a high-quality spectrum analyzer and the rugged ease of use expected in a field instrument.

### Fast measurements

The ESA-L series gives you  $\geq 28$  measurement updates/second to the display and  $\geq 30$  measurement updates/second over GPIB. Also, the state-of-the-art 4 ms sweep time reduces test time and increases throughput.

### Accurate results

The continuously phase-locked synthesizer adds stability and repeatability to frequency measurements, and the automatic background alignment offers continuous calibration. Plus, you'll have specified performance only 5 minutes after power-up. This includes  $\pm 1.1$  dB absolute amplitude accuracy up to 3.0 GHz and  $\pm 2.6$  dB up to 26.5 GHz.

### Portable operation

Optional snap-on battery eliminates the restrictions of power cords. The optional 12 V-dc power cable allows direct operation from automotive and truck batteries.

### Rugged packaging and construction

Ideal for field environments, the ESA-L series instruments have a sealed front panel, louvered air vents and side-mounted fan to protect the instrument in a wide range of weather conditions. Rubber-encased front and rear frames resist the rigors of transportation.

### Easy to use

The built-in help button gives key function and remote programming commands which eliminates the need to carry manuals. In addition, testing is simplified with built-in limit lines and pass/fail messages. The built-in disk drive makes saving and moving measurement results to your PC quick and easy.

### Low cost

All this at a very affordable price, with a standard 3 year global warranty.

### PC Software for the ESA-L series

BenchLink XL PC software provides easy transfer of ESA measurement trace data directly into MS Excel spreadsheets or screen images into MS Word documents for analysis, archiving, presentations, or printing. Transfer measurement results over GPIB, RS232, or LAN (using two PCs or an E2050A GPIB/LAN adapter). Save and restore analyzer states. Unattended operation with repetitive sequence of measurement transfers by date and time. BenchLink XL is included standard with GPIB and RS232 options.

## Frequency Specifications

### Frequency Range

**E4411B:** 50 ohms: 9 kHz to 1.5 GHz

**E4411B:** 75 ohms (Option 1DP): 1 MHz to 1.5 GHz

**E4403B:** 9 kHz to 3.0 GHz

**E4408B:** 9 kHz to 26.5 GHz

Band	LO harmonic-N	Center Frequency
0	1-	9 kHz to 3.0 GHz
1	1-	2.85 GHz to 6.7 GHz
2	2-	6.2 GHz to 13.2 GHz
3	4-	12.8 GHz to 19.2 GHz
4	4-	18.7 GHz to 26.5 GHz

### Frequency Reference

Aging:  $\pm 2 \times 10^{-6}$ /year

Stability:  $\pm 5 \times 10^{-7}$

Temperature Stability:  $\pm 5 \times 10^{-6}$

### Frequency Readout Accuracy

(Start, Stop, Center, Marker):  $\pm$  (frequency readout x frequency reference error + 0.75% of span + 15% of RBW + 10 Hz + 1 Hz x N<sup>2</sup>)

### Marker Frequency Counter

Resolution: Selectable from 1 Hz to 100 kHz

Accuracy:  $\pm$  (marker frequency x frequency reference error + counter resolution)

### Frequency Span

Range: 0 Hz (zero span), and

E4411B: 100 Hz to 1.5 GHz

E4403B: 100 Hz to 3.0 GHz

E4408B: 100 Hz to 26.5 GHz

Resolution: 2 Hz x N<sup>2</sup>

Accuracy:  $\pm 1\%$  of span

### Sweep Time

Range: 4 ms to 4000 s

Accuracy:  $\pm 1\%$

Sweep Trigger: Free Run, Single, Line, Video, External, Delayed, Offset

Offset Trigger Range:  $\pm 327$  ms to  $\pm 323$  ks

Sweep (Trace) Points: 401

### Resolution Bandwidth

Range

(-3 dB bandwidth): 1 kHz to 3 MHz, in 1-3-10 sequence, and 5 MHz.

(-6 dB bandwidth, EMI): 9 kHz, 120 kHz

Accuracy (1 kHz to 3 MHz RBW):  $\pm 15\%$

(5 MHz RBW):  $\pm 30\%$

Selectivity (60 dB/3 dB bandwidth ratio):  $< 15:1$ , characteristic

### Video Bandwidth Range (-3 dB)

30 Hz to 1 MHz in 1-3-10 sequence. 3 MHz, characteristic.

### Stability

Noise Sidebands (offset from CW signal, 1 kHz RBW, 30 Hz VBW and sample detector)

$\geq 10$  kHz:  $\leq -90$  dBc/Hz + (20 Log N<sup>2</sup> for frequencies  $> 6.7$  GHz)

$\geq 20$  kHz:  $\leq -98$  dBc/Hz + (20 Log N<sup>2</sup> for frequencies  $> 6.7$  GHz)

$\geq 30$  kHz:  $\leq -100$  dBc/Hz + (20 Log N<sup>2</sup> for frequencies  $> 6.7$  GHz)

$\geq 100$  kHz:  $\leq -112$  dBc/Hz + (20 Log N<sup>2</sup> for frequencies  $> 6.7$  GHz)

### Residual FM

1 kHz RBW, 1 kHz VBW:  $\leq 150$  Hz peak-to-peak x N<sup>2</sup> in 100 ms

### System-Related Sidebands, offset from CW signal:

$\geq 30$  kHz:  $\leq -65$  dBc + (20 Log N<sup>2</sup> for frequencies  $> 6.7$  GHz)

## Amplitude Specifications

### Absolute Amplitude Accuracy

Overall Amplitude Accuracy:  $\pm$ (0.6 dB + absolute frequency response)

At reference settings:  $\pm 0.4$  dB

### Measurement Range

Displayed average noise level to maximum safe input level

### Input Attenuator Range:

E4411B: 0 to 60 dB, in 5 dB steps

E4403B, E4408B: 0 to 65 dB, in 5 dB steps

### Maximum Safe Input

Average Continuous Power

E4411B: ( $\geq 15$  dB attenuation): +30 dBm(1W)

E4403B, E4408B: ( $\geq 5$  dB attenuation): +30 dBm(1W)

Peak Pulsed Power

E4411B: ( $\geq 15$  dB attenuation): +30 dBm(1W)

E4403B, E4408B: ( $\geq 30$  dB attenuation): +50 dBm(100W)

ESA-L Series  
E4411B  
E4403B  
E4408B

**1 dB Gain Compression:** (Total power at input mixer)<sup>3</sup>

E4411B, E4403B: 0 dBm;  
E4408B: (50MHz to 6.7 GHz): 0 dBm, (6.7 GHz to 13.2 GHz): -3 dBm,  
(13.2 GHz to 26.5 GHz): -5 dBm

**Displayed Average Noise Level** (Input terminated, 0 dB attenuation, 30 Hz VBW, sample detector, 1 kHz RBW, reference level = -70 dBm)

E4411B:

400 kHz to 10 MHz:  $\leq -115$  dBm  
10 MHz to 500 MHz:  $\leq -119$  dBm  
500 MHz to 1.0 GHz:  $\leq -117$  dBm  
1.0 GHz to 1.5 GHz:  $\leq -113$  dBm

E4403B:

10 MHz to 1GHz:  $\leq -117$  dBm  
1 GHz to 2.0 GHz:  $\leq -116$  dBm  
2.0 GHz to 3.0 GHz:  $\leq -114$  dBm

E4408B:

10 MHz to 1.0 GHz:  $\leq -116$  dBm  
1.0 GHz to 2.0 GHz:  $\leq -115$  dBm  
2.0 GHz to 6.0 GHz:  $\leq -112$  dBm  
6.0 GHz to 12.0 GHz:  $\leq -110$  dBm  
12.0 GHz to 22.0 GHz:  $\leq -107$  dBm  
22.0 GHz to 26.5 GHz:  $\leq -101$  dBm

**Display Range**

Log Scale: 0 to -85 dB from reference level is calibrated; 0.1, 0.2, 0.5 dB/division and 1 to 20 dB/division in 1 dB steps; ten divisions displayed  
Linear Scale: ten divisions

Scale Units: dBm, dBmV, dB $\mu$ V, V, and W**Absolute Frequency Response** (Referenced to 50 MHz, 10 dB attenuation, 20° C to 30° C)

9 kHz to 3.0 GHz:  $\pm 0.5$  dB  
3.0 GHz to 6.7 GHz:  $\pm 1.5$  dB  
6.7 GHz to 26.5 GHz:  $\pm 2.0$  dB

**Resolution Bandwidth Switching Uncertainty** (at reference level and 1 kHz RBW)

3 kHz to 3 MHz RBW:  $\pm 0.3$  dB  
5 MHz RBW:  $\pm 0.6$  dB

**Reference Level**

Range: -149 dBm to maximum mixer level + attenuator setting  
Resolution

Log Scale:  $\pm 0.1$  dB  
Linear Scale:  $\pm 0.12\%$  of reference level

Accuracy: (at a fixed frequency, a fixed attenuation, and referenced to -35 dBm)

Reference Level - Input Attenuator Setting:  
-10 dBm to  $> -60$  dBm:  $\pm 0.3$  dB  
-60 dBm to  $> -85$  dBm:  $\pm 0.5$  dB  
-85 dBm to  $> -90$  dBm:  $\pm 0.7$  dB

**Display Scale Switching Uncertainty**

Linear to Log Switching:  $\pm 0.15$  dB at reference level  
Log Scale Switching: No error

**Display Scale Fidelity**

Log Maximum Cumulative  
0 to -80 dB from reference level:  $\pm (0.3 \text{ dB} + 0.01 \times \text{dB from reference level})$

Log Incremental Accuracy

0 to -80 dB from reference level:  $\pm 0.4$  dB/4 dBLinear Accuracy:  $\pm 2\%$  of reference level**Spurious Responses**

Second Harmonic Distortion

E4411B:  
2 MHz to 750 MHz  $< -75$  dBc for -40 dBm signal at input mixer<sup>3</sup>  
E4403B, E4408B:  
10 MHz to 500 MHz  $< -60$  dBc for -30 dBm signal at input mixer<sup>3</sup>  
500 MHz to 1.5 GHz  $< -70$  dBc for -30 dBm signal at input mixer<sup>3</sup>  
1.5 GHz to 2.0 GHz  $< -80$  dBc for -10 dBm signal at input mixer<sup>3</sup>  
2.0 GHz to 13.25 GHz  $< -95$  dBc for -10 dBm signal at input mixer<sup>3</sup>

Maximum Achievable Second Order Dynamic Range

E4411B: (at 1 GHz) 76 dB (+35 dBm, SHI)  
E4403B: (at 1 GHz) 78.5 dB (+40 dBm, SHI)  
E4408B: (at 1 GHz) 78 dB (+40 dBm, SHI)

Third Order Intermodulation Distortion

E4411B:  
10 MHz to 1.5 GHz  $< -75$  dBc for two -30 dBm signals at input mixer<sup>3</sup>,  $> 50$  kHz separation  
E4403B, E4408B:  
100 MHz to 6.7 GHz  $< -75$  dBc for two -30 dBm signals at input mixer<sup>3</sup>,  $> 50$  kHz separation  
6.7 GHz to 26.5 GHz  $< -70$  dBc for two -30 dBm signals at input mixer<sup>3</sup>,  $> 50$  kHz separation

Maximum Achievable Third Order Dynamic Range

E4411B: (at 1.0 GHz) 83 dB (+7.5 dBm TOI)  
E4403B: (at 1.0 GHz) 83 dB (+7.5 dBm TOI)  
E4408B: (at 1.0 GHz) 82 dB (+7.5 dBm TOI)

Other Input-Related Spurious

E4411B:  $< -65$  dBc, 30 kHz  $\leq$  offset  $\leq 1.2$  GHz, for -20 dBm signal at input mixer<sup>3</sup>  
E4403B, E4408B:  $< -65$  dBc,  $> 30$  kHz offset, for -20 dBm signal at input mixer<sup>3</sup>

**Residual Responses** (Input terminated and 0 dB attenuation):  $< -90$  dBm**AM Demod:** Tune and listen to AM signals**Options****Tracking Generator Specifications (Option 1DN or IDQ)****Output Frequency Range**

E4411B: 50  $\Omega$  (Option 1DN): 9 kHz to 1.5 GHz  
E4411B: 75  $\Omega$  (Option 1DQ): 1 MHz to 1.5 GHz  
E4403B, E4408B: (Option 1DN): 9kHz to 3.0 GHz

**Output Power Level Range**

E4411B: 50  $\Omega$  (Option 1DN): 0 to -70 dBm (20° C to 30° C)  
E4411B: 75  $\Omega$  (Option 1DQ): +42.75 to -27.25 dBmV  
E4403B, E4408B: 50  $\Omega$  (Option 1DN): -2 to -66 dBm

**Dynamic Range:** Output power level - displayed average noise level**General Specifications****Measurement Speed** (Characteristic)

	E4411B	E4403B	E4408B
Local measurement and display update rate <sup>6</sup>	$\geq 35$ /sec	$\geq 30$ /sec	$\geq 28$ /sec
Remote measurement and GPIB transfer rate <sup>7</sup>	$\geq 30$ /sec	$\geq 30$ /sec	$\geq 30$ /sec
RF center frequency tuning time <sup>8</sup>	$\leq 90$ ms	$\leq 90$ ms	$\leq 90$ ms

**Temperature Range**

Operating: 0° C to + 55° C  
Disk Drive: 10° C to 40° C  
Storage: -40° C to + 75° C

**Audible Noise (ISO 7779)**Sound pressure at 25° C:  $< 40$  dBa ( $< 5.3$  Bels power)**Military Specification:** Has been type tested to the environmental specifications of MIL-PRF-28800F Class 3**EMI Compatibility:** Conducted and radiated emission is in compliance with CISPR Pub.11/1990 Group 1 Class A**Power Requirements**

ac Voltage: 90 to 132 Vrms, 195 to 250 Vrms  
Frequency: 47 to 440 Hz, 47 to 66 Hz  
Power Consumption, On:  $< 300$  W  
Power Consumption, Standby:  $< 5$  W  
dc Voltage: 12 to 20 Vdc  
Power Consumption:  $< 200$  W

**Weight (without options)**

E4411B: 13.2 kg (29.1 lb), characteristic  
E4403B: 15.5 kg (34.2 lb), characteristic  
E4408B: 17.1 kg (37.7 lb), characteristic

**Dimensions**

Height: 222 mm (8.75 in)  
Width: 373 mm (14.7 in) w/o handle, 408 mm (16.1 in) w/handle  
Depth: 409 mm (16.1 in) w/o handle, 516 mm (20.3 in) w/handle

## Ordering Information

**E4411B** 9 kHz to 1.5 GHz ESA-L Portable Spectrum Analyzer  
**E4403B** 9 kHz to 3.0 GHz ESA-L Portable Spectrum Analyzer  
**E4408B** 9 kHz to 26.5 GHz ESA-L Portable Spectrum Analyzer

**Opt A4H** GPIB and parallel (Centronics) interfaces  
**Opt 1AX** RS-232 and parallel (Centronics) interfaces  
**Opt A4J** IF, Sweep, and Video Ports  
**Opt 1DN** 50-Ohm tracking generator (9 kHz to 1.5 GHz for E4411B)(9 kHz to 3.0 GHz for E4403B and E4408B)  
**Opt 1DP** 75 Ohm Input Impedance (1 MHz to 1.5 GHz) (E4411B only)  
**Opt 1DQ** 75 Ohm Tracking Generator (1 MHz to 1.5 GHz) (requires Option 1DP)  
**Opt A5D** 12 Vdc power cable  
**Opt 1D7** 50 to 75 Ohm matching pad (type N(m) to BNC (f))  
**Opt UK9** Front panel protective cover  
**Opt 1CP** Rackmount kit with handles and slides  
**Opt 0BW** Assembly level service guide and CD-ROM with adjustments  
**Opt UK6** Commercial calibration certificate with data  
**Opt 0B0** Delete manuals, keep CD-ROM manual  
**Opt 0BV** Component level service documentation  
**Opt AXT** Add hard transit case  
**Opt AYT** Grey soft carrying/operating case  
**Opt AYU** Yellow soft carrying/operating case  
**Opt 042** Custom Analyzer backpack (grey)  
**Opt 044** Custom Analyzer backpack (yellow)  
**Opt BAB** 3.5mm Input connector (E4408B only)

### Accessories

**87405A** Preamplifier (10 MHz to 3 GHz, 24 dB gain) (fastened to RF input, powered from analyzer)  
**85905A** 75 Ohm preamplifier (45 MHz to 1 GHz, 20 dB gain) (powered from analyzer)  
**41800A** Active probe (5 Hz to 500 MHz)  
**85024A** High frequency active probe (300 kHz to 3 GHz)  
**E1779A** Snap-on battery pack  
**N2717A** Performance and adjustment software for calibration of ESA Analyzers

<sup>1</sup>Frequency reference error = (aging rate x period of time since adjustment + settability + temperature stability).

<sup>2</sup>N = Harmonic mixing mode. N = 1 for E4411B and E4403B.

<sup>3</sup>Mixer Power Level (dBm) = Input Power (dBm) – Input Attenuator. (dB). For RBW ≤ 30 kHz, maximum input signal amplitude must be ≤ reference level + 10 dB.

<sup>4</sup>For reference level 0 to –50 dBm: input attenuation, 10 dB; 50 MHz; RBW, 1 kHz; VBW, dc coupled, 1 kHz; log range 0 to –50 dB; sweep time coupled, signal input, 0 to –50 dBm; span, ≤20 kHz, 20° C to 30° C.

<sup>5</sup>For reference level –25 dBm for E4411B, –20 dBm for E4403B and E4408B; input attenuation 10 dB; center frequency 50 MHz; resolution bandwidth 1 kHz; video bandwidth 1 kHz; span 2 kHz; sweep time coupled; signal at reference level.

<sup>6</sup>Factory preset, auto align Off, segmented sweep Off, fixed center frequency, RBW = 1 MHz and spans >10 MHz and ≤600 MHz (>102 MHz and ≤400 MHz E4401B).

<sup>7</sup>Factory preset, display Off, single sweep, markers Off, auto align Off, segmented sweep Off, fixed center frequency, RBW = 1 MHz, span = 20 MHz, and stop frequency ≤3 GHz.

<sup>8</sup>Factory preset, display Off, markers Off, single sweep, auto align Off, segmented sweep Off, RBW = 1 MHz, sweep points = 101, span = 20 MHz, stop frequency ≤3 GHz, and center frequency tune step size = 50 MHz.

## E4444A BenchLink Spectrum

### Analyzer Software

Agilent BenchLink Spectrum Analyzer provides an easy-to-use communications link between your PC and the 8560-series, 8590-series, ESA-E/L series portable spectrum analyzers, E7400 series EMC analyzers; and Agilent CaLan 2010/3010 series sweep/ingress analyzers. BenchLink Spectrum Analyzer is a member of the Agilent BenchLink family of PC/basic instrument connectivity solutions, and takes full advantage of the Windows interface to easily transfer screen images or trace data via GPIB or RS-232 interfaces.

BenchLink Spectrum Analyzer makes it easy to capture, analyze and document measurement results in your PC. Agilent has done all the programming for you.

You'll be able to transfer:

- Screen images—you can transfer a picture of the spectrum analyzer screen to your PC for viewing, annotation, storage, or printing. BenchLink Spectrum Analyzer provides convenient annotation tools, and Windows makes it easy to cut and paste your annotated image into other applications like word processing, presentation, and graphics packages or e-mail. You can also save your image in PCX, TIF, GIF, and BMP formats. You'll find documenting measurement results to be fast and simple.
- Trace data—BenchLink Spectrum Analyzer transfers the trace frequency/amplitude pairs of data from your spectrum analyzer to your PC for further review and analysis. Once the trace data is captured, you can use pan and zoom and trace markers in BenchLink to analyze the trace. Additionally, the frequency/amplitude pairs of trace data can be easily copied as comma-separated-values to spreadsheets or other analysis programs using files or the Windows clipboard.

The software runs on MS Windows 3.1, Windows 3.11, Windows 95, Windows 98, and Windows NT 4.0 and includes a complete context-sensitive on-line help system. System requirements are IBM PC compatible with at least 486-25 MHz processor, 8 MB ram, and 3 MB disk space available.

### Ordering Information

**E4444A** BenchLink Spectrum Analyzer Software

### Remote Operation Software for the 8590 Series

iPanels software for MS Windows 95/NT provides remote operation for 8590 series spectrum analyzers (with GPIB or RS-232 interface). The virtual 8590 series instrument panel created on your PC monitor is easily controlled with a mouse as if you were sitting in front of the analyzer. Remote functionality through modem or LAN varies for different analyzer models and options. Contact Hamilton Software for analyzer compatibility and product details.

**Hamilton Software**  
 2270 Northpoint Parkway  
 Santa Rosa, CA 95407  
 (800) 704-0085  
 (707) 542-2700  
<http://www.hamsoft.com>

Hamilton Software is solely responsible for their products and services. Agilent disclaims any and all liabilities for and makes no warranties, expressed or implied, with respect to these products or services, including without limitation the implied warranties of merchantability and fitness for a particular purpose. Distribution of these products or information concerning these products does not constitute Agilent's endorsement of Hamilton.

ESA-L Series  
 E4411B  
 E4403B  
 E4408B  
 E4444A

5



8590 E-Series

- Easy-to-use, expandable, portable spectrum analyzers
- Full range of price and performance options
- One-button measurements for FFT, TOI, ACP, and more
- Expanded memory and trace-storage capability
- Optional narrow resolution bandwidths
- Custom measurement personalities

### 8590 Series Spectrum Analyzers



The 8590 E-series spectrum analyzers offer a wide range of performance, features, and prices designed to fit your budget. Choose from low-cost, basic performance analyzers or from higher-performance models. Whatever your choice, you will find the 8590 series spectrum analyzers easy to use and reliable. Their expandable feature sets allow them to be easily configured to meet your growing measurement needs.

Application measurement personalities customize the analyzer for tasks such as cable TV, EMC, digital cellular radio, RF communication, noise-figure and scalar network analysis measurements (see page 245). You can also add a variety of printers and other accessories.

### One Spectrum Analyzer for Many Applications

You can change the test capabilities of these spectrum analyzers to fit specific measurement needs. A memory card reader enables you to load application measurement personalities. Complex measurement routines are reduced to a keystroke. An option cardcage, unique to the 8590 E-series, allows you to add circuit-card options for additional capability. Optional built-in tracking generators provide a synchronously swept signal source for stimulus-response measurements. Operating any 8590 series spectrum analyzer requires only minimal training.

### Easy-to-Use Features

Numerous features make it easier to control measurements and to analyze the results. These spectrum analyzers have built-in, automatic calibration to ensure measurement consistency. Frequency panning lets you quickly reposition signals without repeated sweeps. The internal memory allows over 50 traces to be stored, and more can be stored on RAM cards using the memory-card reader. Time and date stamping come standard. Direct output to a printer is available with either the GPIB/parallel or the RS-232/parallel interface option. Both Hewlett-Packard and selected Epson printers are supported.

### PC Software for 8590 Series

The Agilent BenchLink Spectrum Analyzer PC software provides an easy-to-use communications link between your PC and the 8590 series spectrum analyzers. Taking full advantage of the Windows interface, you can easily transfer screen images or trace data via GPIB or RS-232 interfaces, thereby making it easy to capture, analyze, and document measurement results in a PC environment. For more information, see page 235.

### 8591E, 8593E, 8594E, 8595E and 8596E Spectrum Analyzers

These portable spectrum analyzers bring powerful, comprehensive measurement capabilities to RF, microwave and digital applications. Five models offer a choice of frequency coverage starting at 9 kHz and extending to 26.5 GHz.

Performance specifications include low phase noise of  $-105$  dBc at 30 kHz offset and frequency-synthesized accuracy of 2.1 kHz at 1 GHz, which can be improved to 210 Hz with an optional precision frequency reference. Second- and third-order dynamic ranges are 77 and 90 dB, respectively. Calibrated amplitude range is  $+30$  to  $-130$  dBm with Option 130, and calibrated onscreen display range is 70 dB. Narrow resolution bandwidths of 30, 100, 200 EMI and 300 Hz are available on an optional circuit card, which can be added to these analyzers at any time.

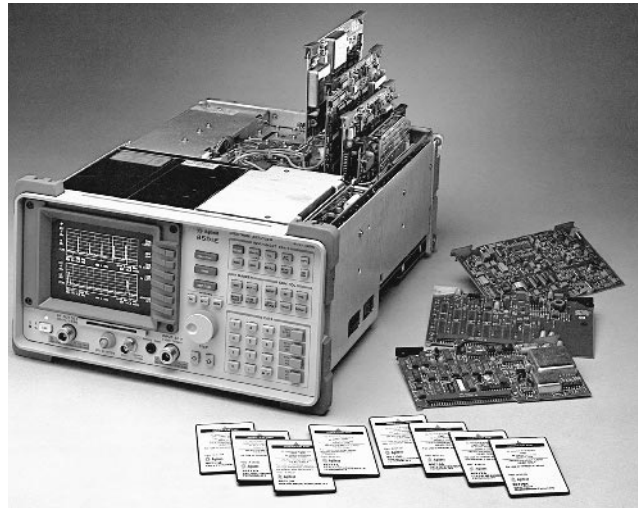

8591E with measurement personality and circuit card options

### Standard Features

A window capability divides the display into two horizontal areas, allowing you to zoom in on critical areas of a measurement trace or to display test data and the trace simultaneously. Many one-button measurements are standard, including a marker table, FFT, N dB bandwidths, third-order intercept, percent AM and adjacent-channel power. A built-in memory card reader allows you to load measurement personalities, your own custom programs and measurement data on 32-, 128-, 256-, and 512-K memory cards.

### Option Flexibility

A wide selection of circuit-card options provides even more measurement capability. Circuit cards are installed easily into a built-in cardcage, and most are retrofittable.

Circuit-card options include:

- Narrow resolution bandwidths of 30, 100, 200 EMI and 300 Hz
- Time-gated spectrum analysis
- "Analog+" display and fast time-domain sweeps
- AM/FM demodulator
- TV receiver/video tester
- Quasi-peak detector
- Noise-figure measurements
- Demodulators for CT2-CAI and DECT
- Digital demodulators and/or digital signal processing for GSM900, DCS-1800, PCS-1900, NADC-TDMA, PHS, CDMA and PDC wireless communication formats

A built-in 1.8 GHz tracking generator (retrofittable) is available for the 8591E, and a 2.9 GHz tracking generator (retrofittable) for the 8593E, 8594E, 8595E and 8596E. The 85902A burst carrier trigger provides a TTL timing reference for digital wireless communication measurements. See page 254.

For more information, visit our web site:

<http://www.agilent.com/find/8590>



- One-button measurement solutions
- Save time, money and training
- Customized for your application
- Easy to use



Easy-to-install measurement personalities

### Measurement Personalities

Measurement personalities are software programs provided on ROM-based memory cards. They customize your 8590 analyzer to perform complex tests simply and quickly with the push of a button from easy-to-follow screen menus. The personalities automatically set the analyzer controls and perform calculations required by application standards, improving accuracy and repeatability.

#### Cable TV and Broadcast

(See page 513 for more information.)

##### 85721A Cable TV Measurements and System Monitor Personality

The 85721A measurement personality customizes the 8591C and 8590 E-series analyzers for easy, non-interfering proof-of-performance measurements on NTSC-, PAL-, or SECAM-format signals. The personality includes the capability to measure power levels for digital carriers. This software adds dedicated cable TV test functions and measurements for channel and system operation. Three video measurements as well as differential gain and phase and chrominance-to-luminance delay inequality can be performed if the spectrum analyzer has Option 107 TV receiver/video tester.

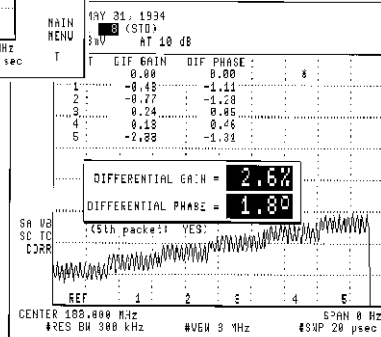
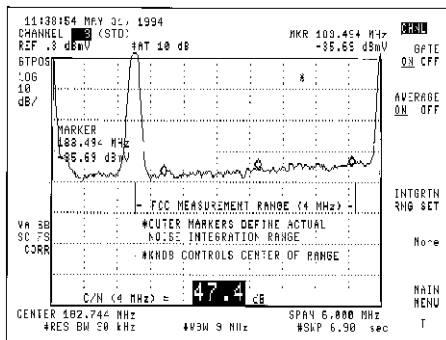

##### 85724A Broadcast Measurement Personality

The 85724A adds measurements for testing TV broadcast transmitters and relays. It allows selection of PAL-I/B/G, NTSC-M and SECAM-D/K systems, channel bands CCIR VHF, UHF, S, M & B, FCC-AIR and PRC and channel number. Tests include carrier level, chroma level, vision, three-tone intermodulation, depth of modulation, spurious signals, NICAM carrier power and intermodulation and FE deviation. Three video measurements as well as differential gain and phase, and chrominance-to-luminance delay inequality can be performed if the spectrum analyzer has Option 107 TV receiver/video tester.

#### Lightwave

##### 11982A Option 001 Lightwave Converter Personality

The 11982A Option 001 personality provides frequency response correction and amplitude conversion of the optical marker for lightwave signals when used with the 11982A amplified lightwave converter and an 8590 series analyzer.

#### Component Test

(See page 250 for more information.)

##### 85714A Scalar Measurement Personality

An 85714A measurement personality and 8590 series analyzer with optional built-in tracking generator make fast, accurate scalar transmission measurements from 100 kHz to 2.9 GHz. Features include guided calibration, pass/fail limit line testing, 120 dB display, bandwidth, Q factor, and shape factor. The 85630A scalar test set adds simultaneous transmission/reflection display.

##### 85719A Noise Figure Measurement Personality

The 85719A noise figure measurement personality customizes an 8590 Option 119 E-series spectrum analyzer for displayed swept noise figure and gain measurements from 10 MHz to 2.9 GHz.

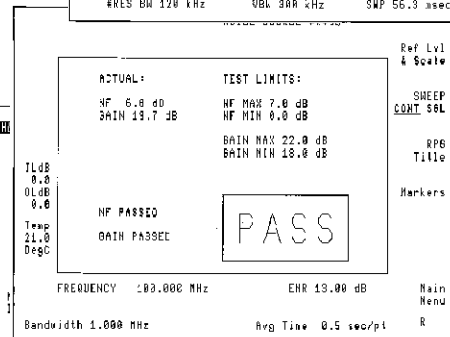
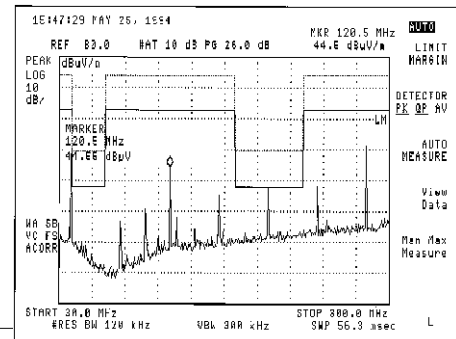



Wide selection of measurement personalities

## Wireless Communications

(See page 383 for more information.)

### 85715B GSM 900 Measurement Personality

The 85715B provides all the GSM900 transmitter tests specified in the GSM 11.10 (mobile) and GSM 11.21 (base) recommendations. Measurements include those for power, frequency, timing and modulation accuracy. GSM Phase II specification limits are used and the extended GSM (E-GSM) frequency bands are supported.

### 85718B NADC-TDMA Measurement Personality

Based on EIA/TIA IS-54 and IS-136 standards, the 85718B simplifies testing of time-division multiple access (TDMA) transmitters for North American Dual-Mode Cellular (NADC) and PCS IS-136 radio systems. The personality provides nine power, frequency and timing tests as well as seven modulation accuracy tests.

### 85720C PDC Measurement Personality

The 85720C provides transmitter measurements for Personal Digital Cellular (PDC) time-division multiple access radio systems. Tests are based on the RCR STD-27C standard. There are 11 power, frequency and timing tests as well as six modulation accuracy tests.

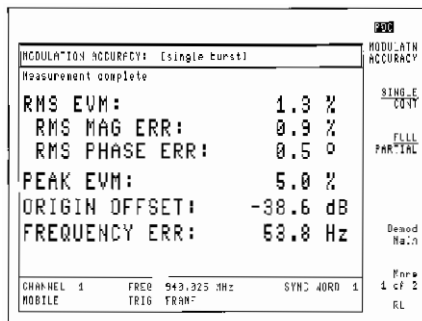
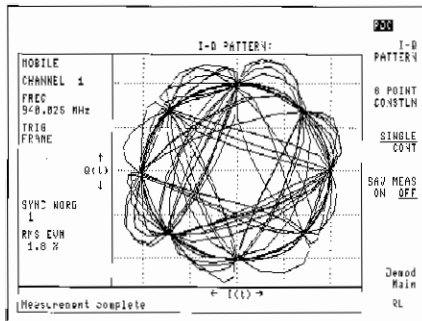

### 85722B DCS1800 Measurement Personality

The 85722B provides all the DCS1800 transmitter tests specified in the GSM 11.10 (mobile) and GSM 11.21 (base) recommendations. Measurements include those for power, frequency, timing and modulation accuracy. Phase II specification limits are used. GSM-based PCS measurements at 1900 MHz may be made using the 85722B special Option H19.

### 85723A DECT Measurement Personality

The 85723A adds the key DECT transmitter measurements to the 8590 E-series analyzers. With the measurement personality, DECT power, frequency, timing and modulation accuracy tests can be made. An optional DECT source built-in to the analyzer can be used as a stimulus for module testing or sensitivity measurements.

### 85725C CDMA Measurement Personality

Simplify your measurements of cellular, PCS and other spread spectrum transmitters based on EIA/TIA IS-95, -97, -98 and J-STD-008 with the 85725C. Frequency- and time-domain measurements are provided. The C version of this personality adds the adjacent channel power ratio (ACPR) measurement, as well as tuning plans for Japan and Korea. The 85725C is designed with a great amount of flexibility, including on-screen help messages, enabling measurements to be easily configured to meet your special needs.

### 85726B PHS Measurement Personality

Measure Personal Handy Phone System (PHS) personal and cell station transmitters operate easily, quickly and reliably. The 85726B PHS personality provides tests based on RCR STD-28. Measurements included are antenna power, adjacent channel power, burst ramp-up and ramp-down power versus time, carrier-off time leakage power, spurious emission, occupied bandwidth and modulation accuracy (EVM).

### 85727A GSM Multi-Band Measurement Personality

For GSM systems operating in more than one GSM band, the 85727A provides all the GSM transmitter tests specified in the GSM 11.10 (mobile) and GSM 11.21 (base) recommendations. Measurements include those for power, frequency, timing and modulation accuracy. GSM phase II specification limits are used and the extended GSM (E-GSM), R-GSM, DCS1800 and PCS1900 frequency bands are supported.

## Digital Radio Measurements

(See page 356 for more information.)

### 85713A Digital Radio Measurement Personality

The 85713A measurement personality for microwave spectrum analyzers includes five major agency masks for testing to US, UK, and FRG digital radio specifications. Automatic compare-to-mask and mean power level measurements are made on the modulated signal. Functions include transient analysis monitoring and frequency response measurement. You can create and store your own masks for later use. For additional digital radio tests, see the 11758V digital radio test system.

### 11770A Link Measurement Personality

The 11770A enables group delay and amplitude flatness measurements on systems that carry digital data, such as microwave radio systems, coax cable and satellite links. Capability includes end-to-end link, DADE, and IF return loss measurements.

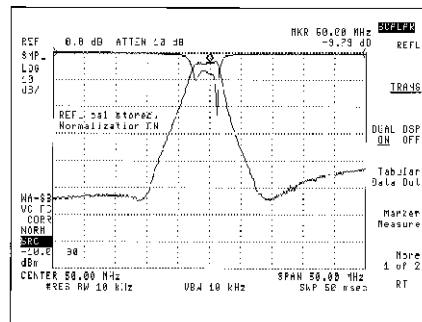



8591E

### 8591E, 8593E, 8594E, 8595E, 8596E

#### Specifications

Specifications apply to any of these analyzers unless otherwise noted.

#### Frequency

##### Frequency Range

###### 8591E:

50 Ω: 9 kHz to 1.8 GHz

75 Ω: 1 MHz to 1.8 GHz

**8594E:** 9 kHz to 2.9 GHz, dc-coupled; 100 kHz to 2.9 GHz, ac-coupled

**8595E:** 9 kHz to 6.5 GHz, dc-coupled; 100 kHz to 6.5 GHz, ac-coupled

	Band	LO harmonic = N	Center frequency
<b>8596E</b>	0	1	9 kHz to 2.9 GHz (dc-coupled)
	0	1	100 kHz to 2.9 GHz (ac-coupled)
	1	1	2.75 to 6.5 GHz
	2	2	6.0 to 12.8 GHz
<b>8593E</b>	0	1	9 kHz to 2.9 GHz
	1	1	2.75 to 6.5 GHz
	2	2	6.0 to 12.8 GHz
	3	3	12.4 to 19.4 GHz
	4	4	19.1 to 22 GHz
	4	4 (Option 026/027)	19.1 to 26.5 GHz

##### Frequency Reference

**Aging:**  $\pm 2 \times 10^{-6}$ /year;  $\pm 1 \times 10^{-7}$ /year (Option 004)

**Temperature Stability:**  $\pm 5 \times 10^{-6}$ ;  $\pm 1 \times 10^{-6}$  (Option 004)

**Initial Achievable Accuracy:**  $\pm 0.5 \times 10^{-6}$ ;  $\pm 2.2 \times 10^{-8}$  (Option 004)

##### Frequency Readout Accuracy (start, stop, center, marker):

$\pm$  (freq. readout x freq. ref error + span accuracy + 1% of span + 20% of RBW + 100 Hz x N)

##### Marker Count Accuracy

Span  $\leq 10$  MHz x N:  $\pm$  (marker freq. x freq. ref error + counter resolution + 100 Hz x N)

Span  $> 10$  MHz x N:  $\pm$  (marker freq. x freq. ref error + counter resolution + 1 kHz x N)

##### Counter Resolution

Span  $\leq 10$  MHz x N: Selectable from 10 Hz to 100 kHz

Span  $> 10$  MHz x N: Selectable from 100 Hz to 100 kHz

##### Frequency Span

**Range:** 0 Hz (zero span) and

**8591E:** 10 kHz to 1.8 GHz; 1 kHz min (Option 130)

**8594E:** 10 kHz to 2.9 GHz; 1 kHz min (Option 130)

**8595E:** 10 kHz to 6.5 GHz; 1 kHz min (Option 130)

**8596E:**  $[10 \times N]$  kHz to 12.8 GHz;  $[1 \times N]$  kHz min (Option 130)

**8593E:**  $[10 \times N]$  kHz to 19.25 GHz;  $[1 \times N]$  kHz min (Option 130)

**Resolution:** Four digits or 20 Hz x N, whichever is greater

##### Accuracy

Span  $\leq 10$  MHz x N:  $\pm 2\%$  of span

Span  $> 10$  MHz x N:  $\pm 3\%$  of span

##### Sweep Time

###### Range

Span = 0 Hz or  $> 1$  kHz: 20 ms to 100 s

Span = 0 Hz (Option 101): 20  $\mu$ s to 100 s

###### Accuracy

20 ms to 100 s:  $\pm 3\%$

20  $\mu$ s to  $< 20$  ms (Option 101):  $\pm 2\%$

**Sweep Trigger:** Free run, single, line, video, external

**Resolution Bandwidth:** 1 kHz to 3 MHz (3 dB) in 1, 3, 10 sequence; 9 kHz and 120 kHz (6 dB) EMI bandwidths. Option 130 adds 30, 100 and 300 Hz (3 dB) bandwidths and 200 Hz (6 dB) EMI bandwidth.

**Accuracy:**  $\pm 20\%$

**Selectivity (characteristic)**

$-60$  dB/ $-3$  dB: 3 kHz to 10 kHz, 15:1

100 kHz to 3 MHz, 15:1

1 kHz, 30 kHz, 16:1

$-40$  dB/ $-3$  dB: 30 Hz to 300 Hz, 10:1

**Video Bandwidth Range:** 30 Hz to 1 MHz in 1, 3 sequence (1 Hz to 1 MHz with Option 130)

##### Stability

**Noise Sidebands (1 kHz RBW, 30 Hz VBW, sample detector)**

$> 10$  kHz offset from CW signal:  $\leq -90$  dBc/Hz + 20 log N

$> 20$  kHz offset from CW signal:  $\leq -100$  dBc/Hz + 20 log N

$> 30$  kHz offset from CW signal:  $\leq -105$  dBc/Hz + 20 log N

##### Residual FM

###### 8591E:

1 kHz RBW, 1 kHz VBW:  $\leq 250$  Hz pk-pk in 100 ms

30 Hz RBW, 30 Hz VBW:  $\leq 30$  Hz pk-pk in 300 ms

###### 8593E, 8594E, 8595E, 8596E:

1 kHz RBW, 1 kHz VBW:  $\leq (250 \times N)$  Hz pk-pk in 100 ms

30 Hz RBW, 30 Hz VBW:  $\leq (30 \times N)$  Hz pk-pk in 300 ms

**System Related Sidebands ( $> 30$  kHz offset from CW signal):**

$\leq -65$  dBc + 20 log N

**Comb Generator Frequency (8593E, 8596E):** 100 MHz fundamental frequency;  $\pm 0.007\%$  frequency accuracy

#### Amplitude

**Amplitude Range:** Displayed average noise level to +30 dBm

**8591 Option 001:** Displayed average noise level to +72 dBmV

**Maximum Safe Input Level (input attenuator  $\geq 10$  dB)**

**Average Continuous Power:** +30 dBm (1 W)

**8591E Option 001:** +72 dBmV (0.2 W)

##### Peak Pulse Power

**8591E:**  $\pm 30$  dBm (1 W)

**8591E Option 001:** +72 dBmV (0.2 W)

**8593E, 8594E, 8595E, 8596E:** +50 dBm (100 W) for  $< 10$   $\mu$ s pulse width and  $< 1\%$  duty cycle, input atten.  $\geq 30$  dB

##### DC

**8591E:** 25 Vdc

**8591E Option 001:** 100 Vdc

**8593E:** 0 Vdc

**8594E, 8595E, 8596E:** 0 V (dc-coupled); 50 V (ac-coupled)

**Gain Compression ( $> 10$  MHz):**  $\leq 0.5$  dB (total power at

input mixer =  $-10$  dBm)

**Displayed Average Noise Level (input terminated, 0 dB atten., 30 Hz VBW or 1 Hz VBW with Option 130, sample detector)**

	30 Hz RBW	1 kHz RBW
<b>8591E</b>		
400 kHz to 1 MHz	$\leq -130$ dBm	$\leq -115$ dBm
1 MHz to 1.5 GHz	$\leq -130$ dBm	$\leq -115$ dBm
1.5 GHz to 1.8 GHz	$\leq -128$ dBm	$\leq -113$ dBm
<b>8591E Option 001</b>		
1 MHz to 1.5 GHz	$\leq -78$ dBmV	$\leq -63$ dBmV
1.5 GHz to 1.8 GHz	$\leq -76$ dBmV	$\leq -61$ dBmV
<b>8594E</b>		
400 kHz to 5 MHz	$\leq -122$ dBm	$\leq -107$ dBm
5 MHz to 2.9 GHz	$\leq -127$ dBm	$\leq -112$ dBm
<b>8595E</b>		
400 kHz to 2.9 GHz	$\leq -125$ dBm	$\leq -110$ dBm
2.75 to 6.5 GHz	$\leq -127$ dBm	$\leq -112$ dBm
<b>8596E</b>		
400 kHz to 2.9 GHz	$\leq -125$ dBm	$\leq -110$ dBm
2.75 to 6.5 GHz	$\leq -127$ dBm	$\leq -112$ dBm
6.0 to 12.8 GHz	$\leq -115$ dBm	$\leq -100$ dBm
<b>8593E</b>		
400 kHz to 2.9 GHz	$\leq -127$ dBm	$\leq -112$ dBm
2.75 to 6.5 GHz	$\leq -129$ dBm	$\leq -114$ dBm
6.0 to 12.8 GHz	$\leq -117$ dBm	$\leq -102$ dBm
12.4 to 19.4 GHz	$\leq -113$ dBm	$\leq -98$ dBm
19.1 to 22 GHz	$\leq -107$ dBm	$\leq -92$ dBm
<b>8593E Option 026/027</b>		
19.1 to 26.5 GHz	$\leq -102$ dBm	$\leq -87$ dBm



8590 E-Series  
8591E  
8593E  
8594E  
8595E  
8596E

## Specifications (cont.)

## Spurious Responses

## Second Harmonic Distortion

**8591E** (5 MHz to 1.8 GHz): < -70 dBc for -45 dBm tone at input mixer

**8593E** (10 MHz to 2.9 GHz): < -70 dBc for -40 dBm tone at input mixer

**8594E, 8595E, 8596E** (> 10 MHz): < -70 dBc for -40 dBm tone at input mixer

**8593E, 8595E, 8596E** (> 2.75 GHz): < -100 dBc for -10 dBm tone at input mixer (or below DANL)

## Third-Order Intermodulation

**8591E** (5 MHz to 1.8 GHz): < -70 dBc for two -30 dBm tones at input and > 50 kHz separation

**8593E, 8594E, 8595E, 8596E** (> 10 MHz): < -70 dBc for two -30 dBm tones at input and > 50 kHz separation

**Other Input-Related Spurious** ( $\geq$  30 kHz offset, -20 dBm tone at input mixer)

**8591E, 8594E, 8595E, 8596E**: < -65 dBc

**8593E**: < -65 dBc (applied frequency  $\leq$  18 GHz); < -60 dBc (applied frequency  $\leq$  22 GHz)

## Residual Responses (input terminated, 0 dB attenuation)

**1 MHz to 1.8 GHz** (8591E Option 001): < -38 dBmV

**150 kHz to 1.8 GHz** (8591E): < -90 dBm

**150 kHz to 2.9 GHz** (8594E): < -90 dBm

**150 kHz to 6.5 GHz** (8593E, 8595E, 8596E): < -90 dBm

## Display Range

**Log Scale**: 0 to -70 dB from ref level is calibrated; 0.1, 0.2, 0.5 dB/div and 1 to 20 dB/div in 1 dB steps; 8 div displayed

**Linear Scale**: 8 divisions

**Scale Units**: dBm, dBmV, dB $\mu$ V, V, W

## Marker Readout Resolution

**Log Scale**: 0.05 dB

**Linear Scale**: 0.05% of ref level

**Fast Time Sweep for Zero Span** (Option 101 or 301, 20  $\mu$ s to 20 ms)

**$\leq$  1 GHz**: 0.7% of ref level for linear scale

**> 1 GHz**: 1.0% of ref level for linear scale

## Reference Level

**Range**: Same as amplitude range

**Resolution**:  $\pm$  0.01 dB for log scale;  $\pm$  0.12% of ref level for linear scale

**Accuracy**:  $\pm$  0.3 dB at -20 dBm; 0 to -59.9 dBm:  $\pm$  (0.3 dB + 0.01  $\times$  dB from -20 dBm)

## Frequency Response (10 dB input attenuation)

**Absolute** (referenced to 300 MHz CAL OUT)

**8591E, 8594E**:  $\pm$  1.5 dB

**8595E**:  $\pm$  1.5 to  $\pm$  2.0 dB

**8596E**:  $\pm$  1.5 to  $\pm$  2.5 dB

**8593E**:  $\pm$  1.5 to  $\pm$  5.0 dB (preselector peaked)

**Relative Flatness** (referenced to midpoint between highest and lowest frequency response deviations)

**8591E, 8594E**:  $\pm$  1.0 dB

**8595E**:  $\pm$  1.0 to  $\pm$  1.5 dB

**8596E**:  $\pm$  1.0 to  $\pm$  2.0 dB

**8593E**:  $\pm$  1.0 to  $\pm$  2.0 dB (preselector peaked)

**Calibrator Output Amplitude**: -20 dBm  $\pm$  0.4 dB; +28.75 dBmV  $\pm$  0.4 dB, 8591 Option 001

**Resolution Bandwidth Switching Uncertainty** (ref to 3 kHz RBW, at ref level)

**3 kHz to 3 MHz RBW**:  $\pm$  0.4 dB

**1 kHz RBW**:  $\pm$  0.5 dB

**30 Hz to 300 Hz RBW**:  $\pm$  0.6 dB

**Log to Linear Switching**:  $\pm$  0.25 dB at ref level

## Display Scale Fidelity

**Log Incremental Accuracy** (0 to -60 dB from ref level):  $\pm$  0.4 dB/4 dB

**Log Maximum Cumulative** (0 to -70 dB from ref level)

**3 kHz to 3 MHz RBW**:  $\pm$  (0.3 + 0.01  $\times$  dB from ref level)

**30 Hz to 1 kHz RBW**:  $\pm$  (0.4 + 0.01  $\times$  dB from ref level)

**Linear Accuracy**:  $\pm$  3% of ref level

## General Specifications

**MIL-T-28800**: Has been type-tested to the environmental specifications of MIL-T-28800 Class 5

## Temperature

**Operating**: 0° C to +55° C

**Storage**: -40° C to +75° C

**EMI Compatibility**: Conducted and radiated interference CISPR Pub. 11 and Messemphaenger Postverfuegung 526/527/79

**Audible Noise**: < 37.5 dBA pressure and < 5.0 Bels power (ISODP7779)

## Power Requirements

**On** (line 1): 90 to 132 V rms, 47 to 440 Hz

195 to 250 V rms, 47 to 66 Hz

Power consumption < 500 VA; < 180 W

**Standby** (line 0): Power consumption < 7 W

**User Program Memory** (nominal): 238 KB nonvolatile RAM

## Data Storage (nominal)

**Internal**: 24 traces or 32 states

**External**: 50 traces, 8 states

**Memory Cards**: 85700A (32 KB), 24 traces or 32 states;

85702A (128 KB), 99 traces or 128 states

**Video Cassette Recorder** (VCR): Continuous video recording of display supported through composite video output

**Size** (nominal, without handle, feet, or cover): 163 mm H x 325 mm W x 427 mm D (6.52 in x 13 in x 17.08 in)

**Weight**: 14.5 kg (31.9 lb) (8591E); 16.4 kg (36.08 lb) (8593E, 8594E, 8595E, 8596E)

## Option 010 and 011 Built-In Tracking Generators

Option 010 (50  $\Omega$ ) is available for all 8590 E-series spectrum analyzers.

Option 011 (75  $\Omega$ ) is available for the 8591E only.

## Frequency Range

**Option 010**: 100 kHz to 1.8 GHz (8591E); 9 kHz to 2.9 GHz

(8593E, 8594E, 8595E, 8596E)

**Option 011**: 1 MHz to 1.8 GHz (8591E)

## Output Level

## Range

**Option 010**: 0 to -70 dBm (8591E);

-1 to -66 dBm (8593E, 8594E, 8595E, 8596E)

**Option 011**: +42.8 to -27.2 dBmV (8591E)

**Resolution**: 0.1 dB

**Absolute Accuracy**:  $\pm$  1.0 dB (8591E);  $\pm$  0.75 dB (8593E, 8594E, 8595E, 8596E)

## Vernier

**Range**: 10 dB (8591E); 9 dB (8593E, 8594E, 8595E, 8596E)

**Accuracy**:  $\pm$  0.75 dB (8591E);  $\pm$  0.5 dB (8593E, 8594E, 8595E, 8596E)

**Output Flatness**:  $\pm$  1.75 dB (8591E);  $\pm$  2.0 dB, > 10 MHz (8593E, 8594E, 8595E, 8596E)

## Spurious Output

**Harmonic Spurs**: 0 dBm +42.8 dBmV output, < -25 dBc (8591E);

-1 dBm output, < -25 dBc (8593E, 8594E, 8595E, 8596E)

**Nonharmonic Spurs**: < -30 dBc (8591E);  $\leq$  -27 dBc, 300 kHz to 2.0 GHz,  $\leq$  -23 dBc, 2.0 GHz to 2.9 GHz (8593E, 8594E, 8595E, 8596E)

**Dynamic Range** (characteristic; max. output level -TG feedthrough)

**Option 010**: 106 dB (8591E); 106 dB (8594E, > 400 kHz);

109 dB (8595E, 8596E, > 400 kHz); 111 dB (8593E, > 400 kHz)

**Option 011**: 100 dB

## Power Sweep

## Range

**Option 010**: -75 dBm to 0 dBm (8591E); -66 dBm to -1 dBm in 8 dB increments (8593E, 8594E, 8595E, 8596E)

**Option 011**: -32.2 to +42.8 dBmV (8591E)

**Resolution**: 0.1 dB



**Key Literature**

8590 Series Configuration Guide, p/n 5963-6858E

8590 E-Series Data Sheet, p/n 5963-6909E

8590 Series Brochure, p/n 5963-6908E

For information on compatible printers, visit the web site:

<http://www.agilent.com/find/pcg>

**Ordering Information**

**8591E** Spectrum Analyzer, 9 kHz to 1.8 GHz

**8594E** Spectrum Analyzer, 9 kHz to 2.9 GHz

**8595E** Spectrum Analyzer, 9 kHz to 6.5 GHz

**8596E** Spectrum Analyzer, 9 kHz to 12.8 GHz

**8593E** Spectrum Analyzer, 9 kHz to 22 GHz

**Options<sup>1</sup>**

**Opt 001** 75 Ω Input (8591E only)

**Opt 004** Precision Frequency Reference

**Opt 009** LO and Sweep + Tune

**Opt 010** Tracking Generator (100 kHz to 1.8 GHz, 8591E only)

**Opt 010** Tracking Generator (9 kHz to 2.9 GHz)

**Opt 011** Tracking Generator (75 Ω, 8591E only)

**Opt 012** Source for DECT Receiver Test

**Opt 015** Soft Tan Carrying/Operating Case

**Opt 016** Soft Yellow Carrying/Operating Case

**Opt 026** 26.5 GHz Frequency Extension, APC-3.5 mm Connector (8593E only)

**Opt 027** 26.5 GHz Frequency Extension, Type-N Connector (8593E only)

**Opt 040** Front Panel Protective Cover With Storage

**Opt 041** GPIB and Parallel Printer Interfaces

**Opt 042** Custom analyzer backpack (grey)

**Opt 043** RS-232 and Parallel Printer Interfaces

**Opt 044** Custom analyzer backpack (yellow)

**Opt 050** Improved Amplitude Accuracy (NADC-TDMA bands)

**Opt 051** Improved Amplitude Accuracy for PDC Bands

**Opt 052** Improved Amplitude Accuracy for PHS Band

**Opt 053** Improved Amplitude Accuracy for CDMA Bands

**Opt 101** Fast Time-Domain Sweeps and Analog+ Display

**Opt 102** AM/FM Demodulator and TV Sync Trigger (TV Sync requires Option 101)

**Opt 103** Quasi-Peak Detector, AM/FM Demodulator

**Opt 105** Time-Gated Spectrum Analysis

**Opt 107** TV Receiver Video Tester

**Opt 110** CT2 Demodulator

**Opt 111** Group Delay and Amplitude Flatness<sup>3</sup> (8593/4/5/6E only) (Requires 11770A Link Measurement Personality)

**Opt 112** DECT Demodulator

**Opt 119** Noise Figure

**Opt 130** Narrow Resolution Bandwidths (30 to 300 Hz and 200 Hz EMI)

**Opt 140** Narrow Bandwidths and Precision Frequency Reference

**Opt 151** DSP, FAST ADC, and Digital Demodulator

**Opt 160** PDC, PHS, NADC, and CDMA Firmware for Option 151

**Opt 163** GSM900/DCS1800 Firmware for Option 151

**Opt 180** TV Picture NTSC/PAL/SECAM

**Opt 301** TV Sync Trigger, Fast Time-Domain Sweeps, AM/FM Demodulator, Analog+ Display

**Opt 711** 50/75 Ω Matching Pad/100 Vdc Block

**Opt 008** Factory Service Training

**Opt BD0** Code Division Multiple Access

**Opt BD1** Global System for Mobile Communication

**Opt BD2** North American Digital Cellular System

**Opt BD3** Pacific Digital Cellular System

**Opt BD4** Personal Handyphone System

**Opt B70** BenchLink Spectrum Analyzer s/w

**Opt UK6** Commercial Calibration Certificate with Test Data

**Opt ABX** Quick Reference Guide in Local Languages

**Opt W30** Two Additional Years Return-to-Agilent Service

**Opt W32** Two Additional Years Return-to-Agilent Calibration

**Application Measurement Cards/Personalities<sup>2</sup>**

**11770A** Link Measurement Personality

**85700A** Blank 32-KB Memory Card

**85702A** Blank 128-KB Memory Card

**85704A** Blank 256-KB Memory Card

**85705A** Blank 512-KB Memory Card

**85713A** Digital Radio Measurement Personality

**85714A** Scalar Measurement Personality

**85715B** GSM900 Measurement Personality

**85718B** NADC-TDMA Measurement Personality

**85719A** Noise-Figure Measurement Personality

**85720C** PDC Measurement Personality

**85721A** Cable TV Measurement Personality

**85722B** DCS1800 Measurement Personality

**85723A** DECT Measurement Personality

**85724A** Broadcast Measurement Personality

**85725C** CDMA Measurement Personality

**85726B** PHS Measurement Personality

**85727A** GSM Multi-band Measurement Personality

**Accessories**

**10833A** GPIB Cable (1 m)

**24542U** RS-232 Cable 3 Meter (9 Pin F to 9 Pin F)

Option 043 Only (for RS-232 9 Pin PC Connection to Analyzer)

**24542G** RS-232 Cable 3 Meter (25 Pin M to 9 Pin F)

Option 043 Only (for RS-232 25 Pin PC or Printer Connection to Analyzer)

**C2932A** RS-232 Cable 3 Meter (9 Pin M to 9 Pin F)

Option 043 Only (for Serial 9 Pin LaserJet 4P/4Plus Connection to Analyzer)

**C2950A** IEEE-1284 A-B Parallel Cable (2 m)

<sup>1</sup>Most options can be retrofitted. Please contact your local Agilent sales representative.

<sup>2</sup>Some measurement personalities are not supported by all 8590 series models.

For complete information, please contact the Agilent Call Center in your region.

<sup>3</sup>11770A required.

8560EC Series

- Continuous 30 Hz to 2.9, 6.5, 13.2, 26.5, 40, or 50 GHz sweeps
- Resolution bandwidths of 1 Hz to 100 Hz digitally implemented for measurement speed
- Low phase noise and wide dynamic range
- Precision timebase and 1 Hz counter resolution
- Adjacent channel power, channel power, carrier power and gated video measurements standard
- Class 3 MIL-rugged
- Color screen
- VGA output



8560EC

### 8560EC Series Spectrum Analyzers



The 8560EC series portable spectrum analyzers offer the measurement capabilities and performance traditionally found only in larger, more expensive benchtop analyzers. These spectrum analyzers combine outstanding phase noise, sensitivity, 1 Hz resolution bandwidths and wide dynamic range in a Class 3 MIL-rugged package built to withstand harsh environmental conditions.

#### Capabilities for RF Communications

The ability to measure adjacent channel power (ACP) on today's wireless telephones, pagers and other transmitters is critical in both R&D and manufacturing. The 8560EC series spectrum analyzers offer a complete solution for ACP testing of burst carrier signals using digital modulation such as is used in NADC-TDMA, GSM, DECT, CT2-CAI, PDC and PHS systems. Many of the implementation difficulties of the established standards have been addressed, providing fast, accurate and easy-to-use ACP measurement capability. Measure W-CDMA adjacent channel power ratio (ACPR) with a dynamic range of at least 70 dB using the 8563EC Option E35 ACPR test set.

Another standard feature is the ability to measure from .10 to 99.99 percent occupied bandwidth.

Time-gated signal analysis is another standard feature that allows you to easily measure time-varying signals such as pulsed RF, time-division multiple access (TDMA), interleaved and burst-modulated. The 85902A burst carrier trigger can supply a TTL trigger signal.

8560EC series specifications have been enhanced. Now, you can get better phase noise, sensitivity, dynamic range and frequency response from this high performance portable spectrum analyzer family.

The 8562EC spectrum analyzer provides a 13.2 GHz frequency range with increased dynamic range and third-order intercept (TOI) capability. This allows wireless communications engineers to test high-performance components in burst operation systems.

With the 85672A spurious response measurements utility, you can use 8560EC series spectrum analyzers to make fast and easy spurious response tests.

For more information on RF communications measurement capabilities, refer to page 387.

#### Fast Digital Resolution Bandwidths

Digitally-implemented resolution bandwidths of 1, 3, 10, 30 and 100 Hz allow the 8560EC series spectrum analyzers to sweep from 3 to 600 times faster than is possible with comparable analog filters. A narrow 5:1 shape factor allows you to view close-in, low-level signals easily. Digital bandwidths also provide the spectrum analyzer with a full 100 dB on-screen calibrated display.

#### PC Software for 8560EC Series

The new Agilent BenchLink Spectrum Analyzer PC software provides an easy-to-use communications link between your PC and the 8560EC series spectrum analyzers. Taking full advantage of the Windows interface, you can easily transfer screen images or trace data via the GPIB interface, thereby making it easy to capture, analyze and document measurement results in your PC. For more information, see page 235.

#### Precision Frequency and Amplitude

Measure frequencies accurately using the built-in frequency counter. A standard precision frequency reference, with an aging rate of  $1 \times 10^{-7}$  per year, and 1 Hz counter resolution provide confidence in measurement accuracy. At 1 GHz, frequency accuracy of  $\pm 135$  Hz after a 15-minute warmup is achieved.

Amplitude measurement uncertainty can be reduced using the amplitude correction (AMPCOR) feature. AMPCOR allows you to enter up to 200 amplitude correction points to compensate for sources of amplitude uncertainty, such as cable losses, preamplifier gain and spectrum analyzer frequency response. After developing a table of correction data, amplitudes that have been referenced to a power meter can be read directly on the spectrum analyzer display.

#### Digitized, Fast Time-Domain Sweeps

Digitized fast time-domain (zero span) sweeps use markers, trace math, trace storage and get hardcopy output, for measurements such as rise/fall times, pulse widths and time between events.

### 8560EC and 8561EC RF Spectrum Analyzers

The 8560EC and 8561EC offer excellent performance for RF design, manufacturing and service applications. The 8560EC has a frequency range of 30 Hz to 2.9 GHz, and the 8561EC extends this range up to 6.5 GHz. Both have synthesized tuning for drift-free accurate measurements.

### 8562EC RF Spectrum Analyzer

The 8562EC is a high-performance spectrum analyzer that provides the frequency and dynamic range needed for today's high-speed digital wireless communication applications. It allows manufacturing and R&D engineers to test network components with state-of-the-art performance. The 8562EC has a frequency range of 30 Hz to 13.2 GHz, which covers the spur-search ranges specified by leading standards organizations in Europe and in the United States.

### 8563EC Microwave Spectrum Analyzer

The 8563EC extends the outstanding features and capabilities of the 8560EC series RF spectrum analyzers into the microwave frequency range. The 8563EC has a standard frequency range of 9 kHz to 26.5 GHz (preselected from 2.75 GHz to 26.5 GHz), with optional low-end frequency coverage to 30 Hz. The image-enhanced, double-balanced harmonic mixer of the 8563EC achieves noise-figure performance similar to that of a fundamentally-mixed front end.

### 8564EC and 8565EC Millimeter Spectrum Analyzers

Whether you want to measure the third harmonic of a 15 GHz oscillator or the noise sidebands of a 38 GHz carrier, the 8564EC and 8565EC make spectrum analysis easier than ever before. A single coaxial connection is all you need to measure signals from 30 Hz to 50 GHz. Preselection minimizes images and multiple responses at higher frequencies.

The 8564EC has a frequency range of 9 kHz to 40 GHz, the 8565EC of 9 kHz to 50 GHz. Both have optional low-end coverage to 30 Hz and are preselected above 2.75 GHz.

### 8563EC E35 Adjacent Channel Power Ratio Test Set

Use the special option E35 with the 8561EC/62EC/63EC/64EC/65EC spectrum analyzers to increase the dynamic range of ACP measurements. Option E35 uses an alternate first converter mixer with custom filtering to increase the spectrum analyzer's ACPR measurement dynamic range. The dynamic range becomes at least 70 dB for systems with a guard band between channels of 900 kHz or greater. This meets the needs of emerging W-CDMA specifications. Control menus are integrated into the spectrum analyzer softkeys making the test set easy to use.

### 11970 Series and 11974 Series Millimeter Mixers

For millimeter-wave measurements<sup>1</sup>, preselection can be extended to 75 GHz using the 11974 mixers. Unpreselected frequency range can be extended to 110 GHz using the 11970 series mixers, and to 325 GHz using mixers from other manufacturers.

### 85620A Mass Memory Module

This standard plug-in module adds measurement personality capability, enough memory to store 100 traces, memory-card capability and computer capability, without an external controller. Create complex measurement routines and save them as single-key measurements stored on memory cards or in the module's 128 KB of battery-backed RAM. A clock/calendar and automatic save and execute functions let you configure the spectrum analyzer for unattended, automatic measurements.

### 85629B Test and Adjustment Module

This accessory for the 8560EC/61EC/63EC (limited use on 8562EC/64EC) makes it easier to service your spectrum analyzer. The module plugs into the rear panel of the instrument and automates high-level diagnostics, self tests and adjustment procedures. It performs more than 1,000 troubleshooting adjustments. Readjustments are fast and accurate because the module controls internal analyzer settings as well as external test equipment.

### 85710A Digital Radio Measurement Personality

The 85710A Digital Radio Measurement Personality customizes the 8560EC series spectrum analyzers for digital radio measurements. It contains five agency masks for testing to U.S. FCC, U.K. and FRG speci-

<sup>1</sup> Millimeter-wave coverage is not available with Option 002 on the 8560EC.

fications. A compare-to-mask function allows you to characterize spectral emissions. Other functions include mean power level, transient analysis monitoring and frequency-response measurements. You can also create and store your own custom masks.

### 85671A Phase Noise Measurement Utility

This downloadable program transforms your 8560EC series spectrum analyzer into a phase noise tester. It eliminates the task of hand-drawing phase noise plots. To measure oscillator phase noise, you can generate graphs of phase noise (dBc/Hz) versus log offset frequency without having to manually tune to multiple frequency offsets. Other productivity features include direct phase noise readout, variable filtering (for controlling trade-offs between measurement repeatability and speed), calculation of RMS noise (displayed in radians and degrees), spot-frequency measurements (phase noise measurements at a single offset frequency) and digitized hardcopy and storage.

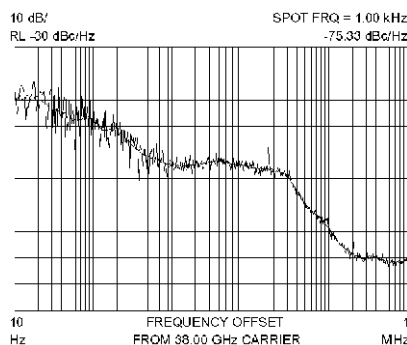

Use the 85671A phase noise utility to easily characterize noise sidebands of an oscillator.

### 85672A Spurious Response Measurements Utility

The 85672A is a downloadable program on a card that inserts directly into any 8560EC series spectrum analyzer. This new test utility provides fast and easy spurious response test capability for all of Agilent's high-performance spectrum analyzers. Test setup time can be drastically reduced for manufacturing and R & D engineers with this one-button solution. 85672A offers five preprogrammed tests: third-order intermodulation product/third order intercept (TOI), harmonics and total-harmonic distortion (THD), discrete sideband spurs, general-spur search and mixing products.

### Scalar Network Analysis Capability

The 85640A tracking generator and the optional built-in tracking generator for the 8560EC both cover 300 kHz to 2.9 GHz. See page 250 for details.

## Specifications

### Frequency

#### Frequency Range (internal mixing)

8560EC:	30 Hz to 2.9 GHz
8561EC:	30 Hz to 6.5 GHz
8562EC:	30 Hz to 13.2 GHz
8563EC:	9 kHz to 26.5 GHz; 30 Hz to 26.5 GHz (Option 006)
8564EC:	9 kHz to 40 GHz; 30 Hz to 40 GHz (Option 006)
8565EC:	9 kHz to 50 GHz; 30 Hz to 50 GHz (Option 006)

**Frequency Range** (external mixing): 18 GHz to 325 GHz in 12 waveguide bands (not available with 8560EC Option 002)

Frequency Reference Accuracy	Option 103	
Temperature Stability	$\pm 1 \times 10^{-6}$	$\pm 1 \times 10^{-6}$
Aging (per year)	$\pm 1 \times 10^{-7}$	$\pm 2 \times 10^{-6}$
Stability	$\pm 1 \times 10^{-6}$	$\pm 1 \times 10^{-6}$

**Warmup** (nominal), 5 minute  $\pm 1 \times 10^{-7}$ ; 15 minute  $\pm 1 \times 10^{-8}$

#### Frequency Readout Accuracy (N = LO Harmonic)

Span > 2 MHz x N:	$\pm$ (freq. readout x freq. ref. accuracy + 5% x span + 15% x RBW + 10 Hz)
Span $\leq$ 2 MHz x N:	$\pm$ (freq. readout x freq. ref. accuracy + 1% x span + 15% x RBW + 10 Hz)

For more information, visit our web site:

<http://www.agilent.com/find/8560>

8560EC Series

**Marker Count Accuracy** (S/N ≥ 25 dB): ± (marker freq. x freq. ref. accuracy + 2 Hz x N + 1 LSD)

**Counter Resolution:** Selectable from 1 Hz to 1 MHz

**Frequency Span**

**Range:** 0 Hz, 100 Hz to maximum frequency

**Sweep Time**

**Range**

Span = 0 Hz: 50 μs to 6,000 s

Span ≥ 100 Hz: 50 ms to 100 ks

**Accuracy** (span = 0 Hz)

Sweep Time > 30 ms: ± 1% digital

Sweep Time < 30 ms: ± 10% analog; ± 0.1% digital

**Sweep Trigger:** Delayed, free run, single, line, video, external

**Resolution Bandwidth:**

**Range** (−3 dB): 1 Hz to 1 MHz in a 1, 3, 10 sequence and 2 MHz

**Accuracy**

1 Hz to 300 kHz: ± 10%; 1 MHz: ± 25%; 2 MHz: +50%, −25%

**Selectivity** (−60 dB/−3 dB)

RBW ≥ 300 Hz: < 15:1; RBW ≤ 100 Hz: < 5:1

**Video Bandwidth Range:** 1 Hz to 3 MHz in a 1, 3, 10 sequence

**Noise Sidebands** (center frequency ≤ 1 GHz)

Offset	Non-Option 103	Option 103
100 Hz	< −88 dBc/Hz	< −70 dBc/Hz
1 kHz	< −97 dBc/Hz	< −90 dBc/Hz
10 kHz	< −113 dBc/Hz	< −113 dBc/Hz
100 kHz	< −117 dBc/Hz	< −117 dBc/Hz

**Residual FM** (zero span): < 1 Hz p-p in 20 ms; < 0.25 Hz p-p in 20 ms (nominal); < 10 Hz p-p in 20 μs (Option 103)

## Amplitude

**Range:** Displayed average noise level to +30 dBm

**Maximum Safe Input Level**

**Average Continuous Power:** +30 dBm (1W, input atten. ≥ 10 dB)

**Peak Pulse Power** (< 10 μs pulse width and < 1% duty cycle): +50 dBm (100 W, input atten. ≥ 30 dB)

**DC Volts:** < ± 0.2 V (dc-coupled); < ± 50 V (ac-coupled, 8560EC, 8561EC and 8562EC only)

**1 dB Gain Compression**

**10 MHz to 2.9 GHz:** mixer level ≤ −5 dBm

**2.9 to 6.5 GHz** (8561EC): mixer level ≤ −3 dBm

**2.9 to 6.5 GHz** (8562EC/63EC/64EC/65EC): mixer level ≤ 0 dBm

> 6.5 GHz: ≤ −3 dBm (8562EC/63EC); ≤ 0 dBm (8564EC/65EC)

**Displayed Average Noise Level** (dB input attenu., 1 Hz RBW)

Frequency	8560EC/61EC	8562EC	8563EC	8564EC/65EC
30 Hz	−90 dBm	−90 dBm	−90 dBm	−90 dBm
1 kHz	−105 dBm	−105 dBm	−105 dBm	−105 dBm
10 kHz	−120 dBm	−120 dBm	−120 dBm	−120 dBm
100 kHz	−120 dBm	−120 dBm	−120 dBm	−120 dBm
1 to 10 MHz	−140 dBm	−140 dBm	−140 dBm	−140 dBm
10 MHz to 2.9 GHz	−149 dBm <sup>1</sup>	−149 dBm	−149 dBm	−145 dBm
2.9 to 6.5 GHz	−145 dBm <sup>2</sup>	−148 dBm	−148 dBm	−147 dBm
6.5 to 13.2 GHz	—	−145 dBm	−145 dBm	−143 dBm
13.2 to 22.0 GHz	—	—	−140 dBm	−140 dBm
22.0 to 26.5 GHz	—	—	−139 dBm	−136 dBm
26.5 to 31.15 GHz	—	—	—	−139 dBm
31.15 to 40.0 GHz	—	—	—	−130 dBm
40.0 to 50.0 GHz	—	—	—	−127 dBm <sup>3</sup>

<sup>1</sup> 10 Hz RBW (Min. RBW with Option 103) add 10 dB to noise floor

<sup>2</sup> 8561EC only

<sup>3</sup> 8565EC only

<sup>4</sup> 8563EC/64EC/65EC only

<sup>5</sup> 8563EC only

<sup>6</sup> 8564EC/65EC only

<sup>7</sup> Except 8561EC

<sup>8</sup> For 8561EC: −145 dBm

<sup>9</sup> TOI reference to single tone

Spurious Responses	Mixer Level	Distortion
General Spurious	−40 dBm	< (−75+20 log N) dBc

**Second Harmonic Dist.**

20 MHz to 1.45 GHz<sup>7</sup> −40 dBm < −79 dBc

1 MHz to 1.45 GHz −40 dBm < −72 dBc

1.45 GHz to 3.25 GHz<sup>2</sup> −20 dBm < −72 dBc

1.45 GHz to 2.0 GHz<sup>4</sup> −10 dBm < −85 dBc

2 GHz to 6.6 GHz<sup>7</sup> −10 dBm < −100 dBc

2.0 GHz to 13.25 GHz<sup>5</sup> −10 dBm < −100 dBc

2.0 GHz to 20 GHz<sup>6</sup> −10 dBm < −90 dBc

20 GHz to 25 GHz<sup>3</sup> −10 dBm < −90 dBc

**3rd Order Intermodulation<sup>9</sup>**

20 MHz to 2.9 GHz<sup>7</sup> −30 dBm < −82 dBc

1 MHz to 2.9 GHz −30 dBm < −78 dBc

2.9 GHz to 6.5 GHz −30 dBm < −90 dBc

6.5 GHz to 26.5 GHz −30 dBm < −75 dBc

26.5 GHz to 40 GHz<sup>6</sup> −30 dBm < −85 dBc (nominal)

40 GHz to 50 GHz<sup>3</sup> −30 dBm ≤ −85 dBc (nominal)

**Images**

10 MHz to 26.5 GHz −10 dBm < −80 dBc

26.5 GHz to 50 GHz −30 dBm < −60 dBc

**Multiples and Out-of-Band Responses**

10 MHz to 26.5 GHz −10 dBm < −80 dBc

26.5 GHz to 50 GHz −30 dBm < −55 dBc

**Residual Responses** (> 200 kHz, N=1): < −90 dBm

**Display**

**Viewing area:** Approx. 7 cm (V) x 9 cm (H)

**Scale calibration:** 10 x 10 divisions

**Log scale:** 10, 5, 2, 1 dB per division

**Linear scale:** 10% of ref. level per division

**Display Scale Fidelity**

**Log:** ± 0.1 dB/dB to a maximum of ± 0.85 dB, 0 to −90 dB;

maximum of ± 1.5 dB, 0 to −100 dB (RBW ≤ 100 Hz)

**Linear:** ± 3% of reference level

**Reference Level Range:** Log = −120 to +30 dBm in 0.1 dB steps;

Linear = 2.2 μV to 7.07 V in 1% steps

**Frequency Response, Relative** (10 dB input atten.)

Frequency	8560EC	8561EC	8562EC	8563EC	8564EC/65EC
100 MHz to 2.0 GHz	± 0.7 dB	± 1.0 dB	± 0.9 dB	± 1.0 dB	± 0.9 dB
30 Hz to 2.9 GHz	± 1.0 dB	± 1.0 dB	± 1.25 dB	± 1.25 dB	± 1.0 dB
2.9 GHz to 6.5 GHz	—	± 1.5 dB	± 1.5 dB	± 1.5 dB	± 1.7 dB
6.5 GHz to 13.2 GHz	—	—	± 2.2 dB	± 2.2 dB	± 2.6 dB
13.2 GHz to 22.0 GHz	—	—	—	± 2.5 dB	± 2.5 dB
22.0 GHz to 26.5 GHz	—	—	—	± 3.3 dB	± 3.3 dB
26.5 GHz to 31.15 GHz	—	—	—	—	± 3.1 dB
31.15 GHz to 40.0 GHz	—	—	—	—	± 2.6 dB
40.0 GHz to 50.0 GHz	—	—	—	—	± 3.2 dB <sup>8</sup>

**Calibrator Output:** 300 MHz x (1 ± freq. ref. acc'y), −10 dBm: < ± 0.3 dB

**Input Attenuator**

**Range**

8560EC/61EC/62EC/63EC: 0 to 70 dB in 10 dB steps

8564EC/65EC: 0 to 60 dB in 10 dB steps

**Switching Uncertainty** (ref. to 10 dB, 30 Hz to 2.9 GHz):

< ± 0.6 dB/10 dB step, ± 1.8 dB max.

**Repeatability:** ± 0.1 dB (nominal)

**IF Gain Uncertainty** (10 dB atten., 0 to −80 dBm ref. level): < ± 1 dB

**Resolution Bandwidth Switching Uncertainty:** < ± 0.5 dB

**Pulse Digitization Uncertainty** (pulse response mode, PRF ≥ 720/sweep time, RBW ≤ 1 MHz): < 1.25 dB pk-pk (Log); < 4% of reference level pk-pk (Linear)

## Time-Gated Spectrum Analysis

**Gate Delay**                      **Edge Mode**                      **Level Mode**

**Range**                              3 μs to 65.535 ms                      ≤ 0.5 μs

**Resolution**                      1 μs

**Accuracy** (from gate trigger input to pos. edge of gate output): < ± 1 μs

**Gate Length**

**Range:** 1 μs to 65.535 ms

**Resolution:** 1 μs

**Accuracy** (from pos. edge to neg. edge of gate output): < ± 1 μs



**Delayed Sweep**

**Trigger Modes:** Free run, line, external, video  
**Range:** 2  $\mu$ s to 65.535  $\mu$ s; Option 007, Sweeptime < 30  $\mu$ s;  
 -9.9  $\mu$ s to +65.535  $\mu$ s; Sweeptime  $\geq$  30  $\mu$ s, +2  $\mu$ s to +65.535  $\mu$ s  
**Resolution:** 1  $\mu$ s  
**Accuracy:**  $\pm$  1  $\mu$ s

**Demodulation** (Spectrum)

**Modulation Type:** AM and FM  
**Audio Output:** Speaker and phone jack with volume control

**Inputs and Outputs** (All values nominal)**Front-Panel Connectors**

**RF Input** (50  $\Omega$ )  
 8560EC/61EC/62EC/63EC, Type-N female  
 8563EC Option 026, APC-3.5 male  
 8564EC/65EC, 2.4-mm male  
**VSWR** ( $\geq$  10 dB atten.): < 1.5:1 below 2.9 GHz; < 2.3:1,  $\geq$  2.9 GHz  
**LO Emission Level** (average with 10 dB atten.): < -80 dBm  
**Second IF Input** (SMA female, 50  $\Omega$ )  
**Frequency:** 310.7 MHz  
**Full Screen Level:** -30 dBm  
**Gain Compression:** -20 dBm  
**First LO Output** (SMA female, 50  $\Omega$ )  
**Frequency:** 3.0 to 6.8107 GHz  
**Amplitude:** +16.5 dBm  $\pm$  2 dB; +14.5 dBm  $\pm$  3 dB (Option 002)  
**Cal Output:** BNC female, 50  $\Omega$   
**Probe Power:** +15 Vdc, -12.6 Vdc, and GND (150 mA maximum each)

**Rear Panel Connectors**

**10 MHz Reference In/Out** (shared BNC female, 50  $\Omega$ )  
**Output Freq. Accuracy:** 10 MHz  $\pm$  (10 x MHz freq. ref. acc'y)  
**Output Amplitude:** 0 dBm  
**Input Amplitude:** -2 to +10 dBm  
**Video Output** (BNC, 50  $\Omega$ )  
**Amplitude** (RBW  $\geq$  300 Hz): 0 to +1 V full scale  
**LO Sweep I FAV Output** (shared BNC female, 2 k $\Omega$ )  
**Amplitude** (LO sweep): 0 to 10 V, no load  
**Blanking/Gate Output:** Shared BNC female, 50  $\Omega$ , TTL output  
**External/Gate Trigger Input** (shared BNC female, > 10 k $\Omega$ ):  
 settable to high TTL or low TTL  
 **GPIB** (IEEE-488 bus connector)  
**Interface Functions:** SH1, AH1, T6, L4, SR1, RL1, PP0, DC1,  
 DT0, C1, C28, E1  
**Interface Functions** (For 8562EC): SH1, AH1, T6, LE0, RL1,  
 PP1, DC1, DT1, C1, C28, TE0, SR1

**General Specifications****Environmental**

**Military Specs:** Class 3 MIL-rugged  
**Calibration Interval:** Two years (8560EC/61EC/62EC/63EC);  
 one year (8564EC/65EC)  
**Warmup Time:** 5 minutes in ambient conditions  
**Temperature:** -10° to +55° C (operating); -51° to +71° C  
 (not operating)  
**Humidity:** 95% at 40° C for five days  
**Rain Resistance:** Drip-proof at 16 liters/hour/sq. ft.  
**Altitude:** 15,000 ft. (operating); 50,000 ft. (not operating)  
**Pulse Shock** (half sine): 30 g for 11 ms duration  
**Transit Drop:** 8-inch drop on six faces and eight corners

**Electromagnetic Compatibility:** Conducted and radiated interference  
 in compliance with CISPR Pub. 11 (1990). Meets MIL-STD-461C, part 4,  
 with certain exceptions.

**Power Requirements**

**115 Vac Operation:** 90 to 140 V rms, 3.2 A rms max., 47 to 440 W  
**230 Vac Operation:** 180 to 250 V rms, 1.8 A rms max., 47 to 66 W

**Maximum Power Dissipation:** 180 W (8560EC/61EC/62EC/63EC);  
 260 W (8564EC/65EC)

**Audible Noise** (nominal): < 5.0 Bels power at room temp. (ISO DP7779)

**Dimensions** (w/o handle, feet, cover): 187 mm H x 337 mm W x 461 mm D  
 (7.48 in x 13.34 in x 18.44 in)

**Weight** (carrying, nominal): 20 kg (44 lb)

**Option 002 Built-in Tracking Generator (8560EC only)****Frequency**

**Range:** 300 kHz to 2.9 GHz  
**Accuracy** (after peaking):  $\pm$  (freq. ref. accuracy x tuned freq. +  
 5% x span + 295 Hz)  
**Tracking Drift** (nominal): Usable in 1 kHz RBW after 5-min.  
 warmup; usable in 300 Hz RBW after 30-min. warmup  
**Minimum RBW:** 300 Hz

**Amplitude**

**Output Level:** -10 to +1 dBm; -10 to 2.8 dBm, typical  
**Resolution:** 0.1 dB  
**Accuracy** (25° C  $\pm$  10° C)  
**Vernier:**  $\pm$  0.2 dB/dB,  $\pm$  0.5 dB max.  
**Absolute:**  $\pm$  0.75 dB  
**Level Flatness:**  $\pm$  2.0 dB

**Dynamic Range:** 95 dB at 300 kHz to 1 MHz; 115 dB at 1 MHz to  
 2.0 GHz; 110 dB at 2.0 GHz to 2.9 GHz

**Power Sweep:** 10 dB range, 0.1 dB resolution

**Inputs/Outputs**

**RF Output** (front panel): Type-N female, 50  $\Omega$  (nominal)  
**Ext. ALC Input** (rear panel): BNC female; use with negative detector

**Key Literature**

8560EC Series Configuration Guide, p/n 5963-6831E  
 8560EC Series Brochure, p/n 5966-3559E  
 8563EC E35 Product Overview, p/n 5966-2913E  
 8560EC Series Technical Specifications, p/n 5965-8078E  
 85671A Product Overview, p/n 5091-7089E  
 85672A Product Overview, p/n 5965-1337E  
 85710A Technical Data, p/n 5952-1452

For more information on compatible printers, visit our web site:

<http://www.agilent.com/find/pcg>

**Ordering Information**

**8560EC** Spectrum Analyzer, 30 Hz to 2.9 GHz  
**8561EC** Spectrum Analyzer, 30 Hz to 6.5 GHz  
**8562EC** Spectrum Analyzer, 30 Hz to 13.2 GHz  
**8563EC** Spectrum Analyzer, 9 kHz to 26.5 GHz  
**8564EC** Spectrum Analyzer, 9 kHz to 40 GHz  
**8565EC** Spectrum Analyzer, 9 kHz to 50 GHz  
**Opt 001** Second IF Output (310.7 MHz)  
**Opt 002** Built-In Tracking Generator (8560EC)  
**Opt 005** Alternate Sweep Out (cannot be used with  
 Opt 002)  
**Opt 006** 30 Hz to Freq. Coverage (8563EC/64EC/65EC)  
**Opt 008** Signal Identification  
**Opt 026** APC-3.5 mm Input Connector (8563EC)  
**Opt 042** Custom Gray Analyzer Backpack  
**Opt 044** Custom Yellow Analyzer Backpack  
**Opt 008** Service Training (8563E124m)  
**Opt 103** Delete Precision Frequency Reference,  
 and 1 Hz and 3 Hz RBWs  
**Opt 104** Delete Mass Memory Module  
**Opt 908** Rackmount Kit without Handles  
**Opt 909** Rackmount Kit with Handles  
**Opt 910** Extra Manual Set  
**Opt 915** Service Guide  
**Opt 916** Extra Quick Reference Guide (English)  
**Opt 1BN** MIL-STD-45662A Calibration (no data)  
**Opt 1BP** MIL-STD-45662A Calibration (with data)  
**Opt E35** ACPR Test Set (8561EC/62EC/63EC/64EC/65EC)  
**Opt UK6** Commercial Calibration (with data)

**Accessories**

**85620A** Mass Memory Module  
**85629B** Test and Adjustment Module  
**85640A** Tracking Generator (300 kHz to 2.9 GHz)  
**8449B** 1 to 26.5 GHz Preamplifier  
**83050A** 2 to 50 GHz Power Preamplifier  
**83051A** 45 MHz to 50 GHz Preamplifier  
**85700A** 32 KB RAM Memory Card  
**85702A** 128 KB RAM Memory Card  
**85671A** Phase Noise Measurements Utility  
**85672A** Spurious Response Measurements Utility  
**85710A** Digital Radio Measurement Personality  
**85901A** Portable AC Power Source  
**85902A** Burst Carrier Trigger  
**41800A** Active Probe (5 Hz to 500 MHz)  
**85024A** High-Frequency Probe (300 kHz to 3 GHz)

85630A  
85640A  
85714A  
85719A

- Noise-figure measurement personality
- High-performance tracking sources
- Scalar measurement personality
- Scalar test set for transmission/reflection measurements

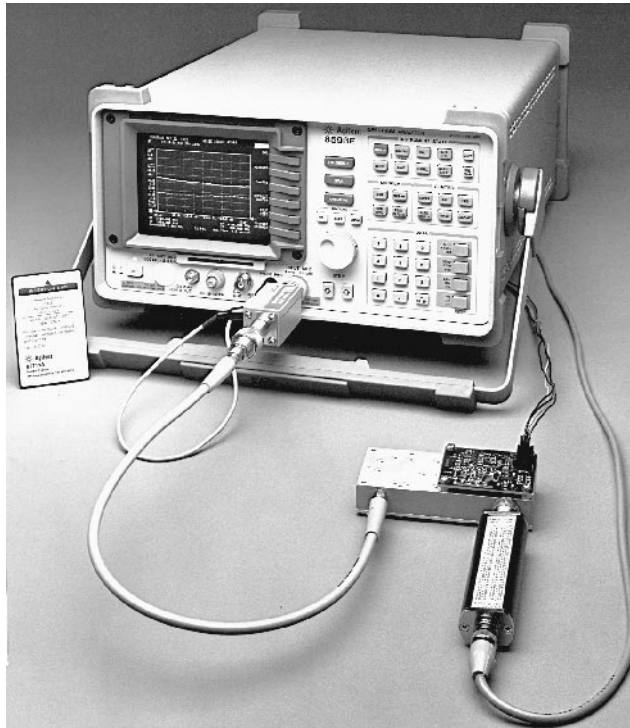

85719A



85630A and 85714A

### 85714A Scalar Measurement Personality 85630A Scalar Transmission/Reflection Test Set

The 85714A is a downloadable program that enhances an 8590 series spectrum analyzer and tracking generator for transmission measurements. The addition of an 85630A scalar test set provides the user interface with a powerful yet economical transmission/reflection measurement system.

The scalar measurement personality adds a number of useful features to the scalar/spectrum analyzer system. These include guided OPEN/SHORT and THRU calibration, pass/fail limit line testing, an enhanced 120 dB display for high, dynamic-range measurements, a tabular display format and one-button measurements for 3 or 6 dB bandwidth, insertion loss/gain, shape factor, Q, and center frequency measurements.

The scalar test set allows you to view transmission and reflection data simultaneously on the screen, so you can make adjustments on a device-under-test while monitoring the results. You can also make calibrated transmission and reflection measurements on a device using a single setup, without the usual need to recalibrate and reconfigure as with spectrum-analyzer-only systems.

Other capabilities provided by the test set include a reflection coefficient measurement marker, VSWR measurement markers, return loss measurement, automatic switching between transmission and reflection mode and source attenuation.

### Accessories for Noise-Figure Measurements

The Agilent 85719A noise-figure measurements personality adds unique capability to an 8590 E-series spectrum analyzer with the Option 119 noise-figure card. Combined with the 346B noise source and 87405A preamplifier, the measurement personality and spectrum analyzer provide displayed swept noise-figure and gain measurements from 10 MHz to 2.9 GHz. Features include one-point measurement capability for quick results, noise-figure and spectrum analyzer mode-switching for stray signal detection, selectable measurement bandwidths to directly measure narrowband devices, and a repeatability calculator to determine measurement time and repeatability tradeoffs.

The noise-figure personality makes use of many features found in the spectrum analyzer. For example, the save/recall functions and the memory-card reader are used to store measurement data, states, displays and ENR data tables. Marker functions make it easy to read noise-figure and gain measurements for the entire sweep, and a menu-driven interface makes the entire system easy to use.

### Accessories for Scalar Network Analysis

A variety of accessories are designed to enhance Agilent spectrum analyzers by adding scalar measurement capability. These powerful solutions allow you to meet both your scalar-network analysis and spectrum analysis needs.

#### 85640A Portable Tracking Generator

This portable tracking generator provides the 8560 EC-series spectrum analyzers with scalar measurement capability from 300 kHz to 2.9 GHz. See page 276.

### Ordering Information

- 85630A Scalar Transmission/Reflection Measurement Test Set
- 85640A Portable Tracking Generator
- 85714A Scalar Measurement Personality
- 85719A Noise-Figure Measurements Personality
- 8590 E-Series Spectrum Analyzers
- Opt 119 Noise-Figure Card
- 346B Noise Source
- 87405A Preamplifier

- Superb performance from 100 Hz to 40 GHz
- Automated, reconfigurable systems
- 8566B code compatibility

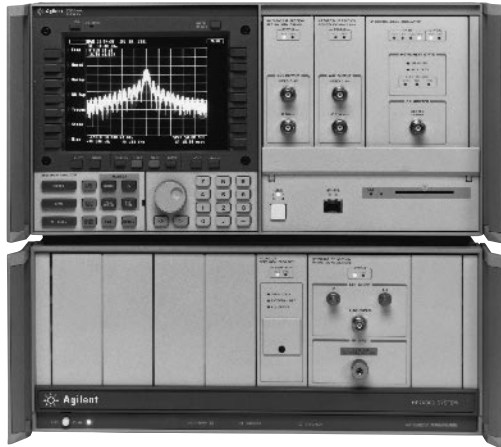

71209A

### 71209A Microwave Spectrum Analyzer

The 71209A is the MMS standard for microwave spectrum analysis, offering exceptional performance for a lower price. Special features include a built-in mixer interface for completely preselected coverage from 100 Hz to 75 GHz (using 11974 series mixers), programming code compatibility with the 8566B spectrum analyzer, similar performance to that of the 71210C, an IF output with AGC, a 5 dB step attenuator and a built-in baseband limiter. Option 001 includes a pre-selector bypass and increases the front-end bandwidth to aid upgrading to the bandwidth receiver system.

71100C  
71200C  
71209A  
71210C

### 70875A Noise-Figure Measurement Personality

The 70875A noise-figure measurement personality customizes 70000 series spectrum analyzers for displayed swept noise-figure and gain measurements from 10 MHz to 26.5 GHz. Features include one-point measurement capability for quick results, noise-figure and spectrum analyzer mode switching for stray signal detection, selectable measurement bandwidths to directly measure narrow-band devices and marker functions with limit lines.

### Key Literature

A complete list of all MMS products with full descriptions, specifications and services is available on our web site: [www.agilent.com](http://www.agilent.com)

## 70000 Series Spectrum Analyzers



The 70000 series spectrum analyzers are part of the growing modular measurement system (MMS) family at Agilent. Four factory-configured spectrum analyzers combine high performance, ease of use and the benefits of modularity for RF and microwave applications:

- 71100C RF spectrum analyzer, 100 Hz to 2.9 GHz
- 71200C microwave spectrum analyzer, 50 kHz to 22 GHz
- 71209A microwave spectrum analyzer, 100 Hz to 26.5 GHz, with an outstanding set of performance features
- 71210C microwave spectrum analyzer, 100 Hz to 22 GHz, with ultimate sensitivity and a dynamic tracking preselector

### Ordering Information

- 71100C Spectrum Analyzer, 100 Hz to 2.9 GHz
- 71200C Spectrum Analyzer, 50 kHz to 22 GHz
- 71209A Spectrum Analyzer, 100 Hz to 26.5 GHz  
     **Opt 001** Wide Bandwidth RF Section  
     **Opt Z40** Spectrum Analyzer, 100 Hz to 40 GHz
- 71210C Spectrum Analyzer

5

## 70000 Series Spectrum Analyzer Specification Summary

	71100C	71200C	71209A	71210C
<b>Frequency range</b> (tunable in 1 Hz increments)	100 Hz to 2.9 GHz (dc-coupled); 100 kHz to 2.9 GHz (ac-coupled)	50 kHz to 22 GHz	100 Hz to 26.5 GHz (100 Hz to 40 GHz Option Z40)	100 Hz to 22 GHz
<b>With external mixers</b>	75 GHz with 11974 preselected mixers; 110 GHz with 11970 harmonic mixers; 325 GHz with other mixers			
<b>Resolution bandwidth range</b>	10 Hz to 300 kHz; 3 MHz option		10 Hz to 3 MHz	
<b>Phase noise</b>	-108 dBc/Hz at 10 kHz offset	-108 dBc/Hz at 10 kHz offset, to 6.2 GHz		
<b>Optimum dynamic range</b> (2nd/3rd order)	82 dB/92 dB	70 dB/88 dB	99 dB/96 dB	96 dB/98 dB
<b>Amplitude accuracy</b> (relative frequency + lesser of scale fidelity or IF gain accuracy)	± 2 dB (± 0.9 dB) <sup>1</sup>	± 2 dB (± 0.9 dB) <sup>1</sup>	± 2 dB (± 0.9 dB) <sup>1</sup>	± 2.5 dB (± 0.9 dB) <sup>1</sup>
<b>Displayed average noise level, 10 Hz RBW</b>				
at 2.9 GHz	-131 dBm	<-129 dBm	-136 dBm	-139 dBm
at 22 GHz	—	<-116 dBm	-128 dBm	-133 dBm
at 26.5 GHz	—	<-115 dBm	-126 dBm	—
<b>Displayed average noise level with 70620 Series preamplifiers</b>				
at 2.9 GHz	-156 dBm	-140 dBm	-155 dBm	-155 dBm
at 22 GHz	—	-119 dBm	-148 dBm	-150 dBm
at 26.5 GHz	—	-155 dBm	-145 dBm	—

<sup>1</sup> ± 0.9 dB transfer accuracy using the 70100A-H01 modular power meter.



71910A



71910A and 71910A Option 11 configurations

## 71910A Receiver

### Modular Receiver for Surveillance and Signal Monitoring

The 71910A is a receiver in the MMS format for monitoring signals from 100 Hz to 26.5 GHz. The receiver provides cost-effective combination search and wide-bandwidth collection capabilities for surveillance and signal monitoring of satellite, digital radio and radar/EW transmissions.

The wide-bandwidth receiver consists of the 71209A Option 001 spectrum analyzer plus the 70911A ultra-wide bandwidth IF module. System options include a preamplifier module for enhanced noise figure and smaller-size, single-mainframe configurations.

### Search and Collection Modes of Operation

The 71910A receiver has two modes of operation: search and collection. To search for signals, the receiver relies on its fast spectrum analyzer tuning. It sweeps over user-specified spans up to 26.5 GHz wide using bandwidths up to 3 MHz. Wide dynamic range ensures that signals of various amplitudes can be quickly identified.

Once a signal is located, the receiver is fixed-tuned and the wide IF bandwidths in the 70911A IF module are used for signal collection. The 70911A provides IF bandwidths up to 100 MHz (in 10% increments) and up to 70 dB IF step gain. A linear IF signal path provides good signal fidelity with standard outputs of 321.4 MHz IF and linear video. Optional outputs include 70 and 140 MHz IF, analog I/Q and demodulated FM.



71910A and 89410 VSA

### Pulse Shape Characterization

Traditional shape measurements of pulsed microwave signals using a spectrum analyzer are significantly enhanced by the 100 MHz bandwidth. Using an oscilloscope connected to the video output, pulse rise and fall times of microwave signals are easily measured to 7 ns.

### I/Q Signal Identification

The optional analog I/Q demodulator provides I and Q outputs which will produce a constellation display on an oscilloscope when the 71910A is tuned to a suitable digitally modulated signal. Sub-Hz tuning (minimum of 1 Hz resolution on-screen) allows ultrafine adjustments to compensate for phase offsets when it is not possible to phaselock the receiver to the source, such as in off-the-air monitoring. By stopping the spinning caused by a non-phaselocked system, modulation formats are easily identified.

When more thorough analysis is required, the I and Q outputs can be connected to a dual-channel vector signal analyzer (VSA). This configuration can provide full-signal demodulation of microwave signals with double the bandwidth normally provided by the VSA alone.

### Digital Demodulation and Vector Signal Analysis

Add high performance digital demodulation and vector signal analysis capability by combining the 71910A and 89410A/89610A VSA. Measurements such as error vector magnitude (EVM) along with constellation, eye diagram and time domain analysis as well as group delay, AM to PM and phase versus drive, for example, can be made on microwave communication signals.

### System Specification Summary

**Frequency Range:** 100 Hz to 26.5 GHz (110 GHz with external mixers)

**Noise Figure at 12 GHz:** 32 dB (13 dB with preamplifier module)

**TOI at 12 GHz:** +2.0 dBm (without preamplifier module)

**Tuning Resolution:** 1 Hz

**LO Phase Noise at 6 GHz:** -108 dBc/Hz at 10 kHz offset

**IF Bandwidths:** 10 Hz to 100 MHz (continuously variable in 10% increments in most cases)

**Spectrum Analyzer RBW:** 10 Hz to 3 MHz

**Receiver IF Bandwidth:** 10 MHz to 100 MHz

**IF Filter Type:** 5-pole, synchronously tuned

**Optional Filter Type:** 6-pole, Chebyshev channel filters

**IF Step Gain:** 70 dB (in 1 dB steps)

#### Outputs

##### 321.4 MHz IF

**Bandwidth:** 10 MHz to 100 MHz (preselector bypass)

**Bandwidth:** > 36 MHz for 2.7 to 26.5 GHz RF path (preselector ON)

**Bandwidth:** > 48 MHz for 100 Hz to 2.9 GHz RF path

**Video:** AM, FM (optional), pulse (bandwidth same as 321.4 MHz IF)

**Optional 70 MHz IF** (bandwidth  $\geq$  40 MHz)

**Optional 140 MHz IF** (bandwidth  $\geq$  70 MHz)

**Optional Analog I/Q** (I bandwidth  $\geq$  50 MHz; Q bandwidth  $\geq$  50 MHz)

### Key Literature

71910A/P Wide Bandwidth Receiver, p/n 5965-7916E

89410A Vector Signal Analyzer, p/n 5964-3586E

### Ordering Information

#### 71910A Wide Bandwidth Receiver

**Opt 001** 70 MHz IF Output

**Opt 002** 140 MHz IF Output

**Opt 004** Analog I/Q Output

**Opt 005** FM Output

**Opt 007** Channel Filters

**Opt 011** Delete Display, NB IFs, PFR (71910A only)

**Opt 016** 7060B Option 001 Preamplifier Module

#### 70911A Ultra-Wide Bandwidth IF Module



- Preselected mixers to eliminate signal identification
- State-of-the-art technology
- Easier automated measurements
- Low conversion loss
- Individually amplitude calibrated
- No bias or tuning adjustments
- High 100 mW safe input level



11970, 11974 Series Mixers

### 11974 Series Preselected Millimeter Mixers

Eliminate the need for signal identification at millimeter frequencies. The Agilent 11974 series mixers are preselected from 26.5 to 75 GHz for faster, easier testing of millimeter devices and systems. Preselection reduces mixer overload from broadband signals and reduces radiation of local oscillator harmonics back to the device under test. Equipment operators can quickly locate true signals, and software development for automated measurements is greatly simplified.

These mixers feature advanced barium-ferrite technology and come with a standalone power supply. They are particularly useful for broadband millimeter signal analysis, millimeter electromagnetic interference (EMI) measurements, and unattended monitoring of millimeter signals.

11974 series preselected mixers are available in four bands

Agilent model	Frequency range (GHz)	Sensitivity <sup>1</sup> (displayed avg. noise level/10 Hz) (dBm)	Calibration accuracy <sup>1</sup> (dB)	Image rejection <sup>1</sup> (dB)	1 dB Gain compression (dBm)
11974A	26.5 to 40	-111	< ±2.3	-54	+6
11974Q	33 to 50	-106	< ±2.3	-50	+0
11974U	40 to 60	-109	< ±2.6	-50	+0
11974V	50 to 75	-100	< ±4.5	-40	+3

<sup>1</sup> Specifications apply when connected to the 8566B or 70000 series spectrum analyzers.

### Compatibility

Upgrade kits are available to assure the compatibility of 8566A/B spectrum analyzers and the 70907A external mixer interface module. Consult your Agilent sales representative to determine requirements. All 8560EC series spectrum analyzers and the 70907B external mixer interface modules are fully compatible with the 11974 series.

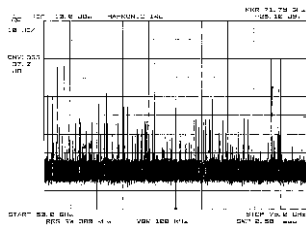

50 to 75 GHz Sweep Without Preselection

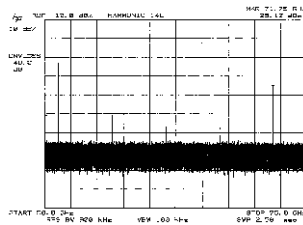

50 to 75 GHz Sweep Using 11974 Series Mixer

### 11970 Series Harmonic Mixers

The 11970 series waveguide mixers are general-purpose harmonic mixers. They employ a dual-diode design to achieve flat-frequency response and low conversion loss. These are achieved without external dc bias or tuning stubs. Manual operation and computer-controlled hardware operation are simplified because mixer bias and tuning adjustments are not required.

11970 series harmonic mixers are available in six bands

Agilent model	Frequency range (GHz)	LO harm number	Conversion loss (dB)	Noise level (dB) 1 kHz RBW	Freq. <sup>1</sup> response (dB)	Gain compression (dBm)
11970K	18 to 26.5	6+	24	-105	± 1.9	-3
11970A	26.5 to 40	8+	26	-102	± 1.9	-5
11970Q	33 to 50	10+	28	-101	± 1.9	-7
11970U	40 to 60	10+	28	-101	± 1.9	-7
11970V	50 to 75	14+	40	-92	± 2.1	-3
11970W	75 to 110	18+	47	-85	± 3.0	-1

<sup>1</sup> Frequency response of the mixers is reduced by 1 dB for LO range of 14 to 18 dBm.

### Compatibility

The 11970 series mixers extend the frequency range of the 8560EC series portable spectrum analyzers, the 8566B spectrum analyzer (used with the 11975A amplifier), and the 70000 modular measurement system (used with the 70907A/B external mixer interface modules).

### 11970 and 11974 Series Specifications

**IF Range:** dc to 1.3 GHz

**LO Amplitude Range:** +14 dB to +16 dB; +16 dB optimum

**Calibration Accuracy:** +2 dB for 11970 series with optimum LO amplitude

**Typical RF Input SWR:** < 2.2:1, < 3.0:1 for 11974 series

**Bias Requirements:** None

**Typical Odd-Order Harmonic Suppression:** > 20 dB

(does not apply to 11974 series)

**Maximum CW RF Input Level:** +20 dBm (100 mW), +25 dBm for 11974 series

**Maximum Peak Pulse Power:** 24 dBm (250 mW) with < 1 μs pulse (avg. power = +20 dBm)

**Bandwidth:** 100 MHz minimum (11974 series only)

**Environmental:** Meets MIL-T-28800, Type III, Class 3, Style C

**IF/LO Connectors:** SMA (female)

**TUNE IN Connector:** BNC

**LO Range:** 3 to 6.1 GHz

### Key Literature

11970 Series Technical Data, p/n 5968-1445E

11974 Series Technical Data, p/n 5952-2748

### Ordering Information

**11974A** 26.5 to 40 GHz Preselected Mixer

**11974Q** 33 to 50 GHz Preselected Mixer

**11974U** 40 to 60 GHz Preselected Mixer

**11974V** 50 to 75 GHz Preselected Mixer

**Opt 003** Delete Power Supply (11974 series only)

**11970K** 18 to 26.5 GHz Mixer

**11970A** 26.5 to 40 GHz Mixer

**11970Q** 33 to 50 GHz Mixer

**11970U** 40 to 60 GHz Mixer

**11970V** 50 to 75 GHz Mixer

**11970W** 75 to 110 GHz Mixer

**11970**

**Opt 009** Mixer Connection Set adds three 1-m low-loss SMA cables, wrench, Allen driver for any 11970 series mixer

**11975A** 2 to 8 GHz Amplifier

**281A/B** Coaxial to Waveguide Adapters

**R281A** 26.5 to 40 GHz, 2.4 mm (f)

**R281B** 26.5 to 40 GHz, 2.4 mm (m)

**Q281A** 33 to 50 GHz, 2.4 mm (f)

**Q281B** 33 to 50 GHz, 2.4 mm (m)

**85640A Portable Tracking Generator**

This portable, rugged tracking generator adds scalar analysis capability from 300 kHz to 2.9 GHz to an 8560 series portable spectrum analyzer. Use the 85640A to measure gain, frequency response, compression, flatness and return loss on components and subsystems. A built-in attenuator gives output power of -80 to 0 dBm. Together, the spectrum analyzer and tracking generator have a dynamic range greater than 100 dB.

**85902A Burst Carrier Trigger**

For performing transmitter tests, this accessory provides a TTL time reference that allows an 8590 A/E-series or 8560 EC-series spectrum analyzer to trigger reliably off the RF signal. It has an input range of 60 dB and a separate built-in preamplifier for greater sensitivity. The 85902A works with all digital communication formats: NADC-TDMA, E-TDMA, PDC, GSM900, DCS-1800, PCS1900, CT2-CAI, DECT and PHS. Frequency range is 10 to 2000 MHz.

**85671A Phase Noise Measurement Utility**

Characterize the phase noise of VCOs and varactor oscillators easily using this downloadable program with an 8560 EC-series portable spectrum analyzer. It provides fast measurements of phase noise versus log offset frequency. Results are displayed graphically and can be stored in the analyzer, printed, or plotted.

**85672A Spurious Response Measurements Utility**

This test utility provides fast and easy spurious response test capability for all of Agilent's high-performance spectrum analyzers. 85672A offers five programmed tests. These are: third-order intermodulation product/third order intercept (TOI), harmonics and total-harmonic distortion (THD), discrete sideband spurs, general-spur search and mixing products.

**8447 Series RF Amplifiers**

These amplifiers, with a frequency range of 9 kHz to 1.3 GHz, have low noise, and wide bandwidths and improve spectrum analyzer sensitivity and noise figure while providing input isolation. See page 335.

**8449B, 83050A and 83051A Preamplifiers**

The 8449B high-gain, low-noise preamplifier has a frequency range of 1 to 26.5 GHz. It increases the sensitivity of any microwave spectrum analyzer for detection and analysis of very low-level signals. Its improved sensitivity can reduce measurement time.

The 83050A and 83051A microwave system amplifiers are compact, off-the-shelf amplifiers designed for system designers and integrators. These amplifiers provide power to recover system losses and to boost available power in RF and microwave ATE systems. The ultra broad bandwidth from 2 to 50 GHz (45 MHz to 50 GHz 83501A) allows the designer to replace several narrow bandwidth amplifiers with a single Agilent amplifier, eliminating the need for crossover networks or multiple bias supplies.

**87405A Preamplifier**

The 87405A preamplifier has a frequency range of 0.01 to 3 GHz. Compact size, 22 to 27 dB gain, 6.5 dB noise figure and convenient probe-power bias connection make it ideal for use with a number of instruments.

**85901A Portable AC Power Source**

This easy-to-carry power source can be used as a standalone battery for over one hour of operation at 100 W continuous load, or can be connected to an external 12 Vdc source for longer use. It shuts off automatically when the charge gets low, and can be recharged in six hours or less. Over-voltage, short-circuit, and overload protection on the inverter output are built in. Also included are over-voltage protection on the inverter input and over-charge and over-discharge protection on the internal battery.

**85629B Test and Adjustment Module**

This accessory for the 8560E, 8561E and 8563E makes it easier to service your spectrum analyzer. The 85629B test and adjustment module plugs into the rear panel of the instrument and automates high-level diagnostics, self-tests and adjustment procedures. It performs more than 1,000 troubleshooting adjustments. Readjustments are fast and accurate because the module controls internal analyzer settings as well as external test equipment.

**11867A, 11693A and 11930B Limiters**

Protect the input circuits of spectrum analyzers, counters, amplifiers and other instruments from high power levels with minimal effect on measurement performance. The 11867A RF limiter (dc to 1.8 GHz) reflects signals up to 10 W average power and 100 W peak power. Insertion loss is less than 0.75 dB. The 11693A microwave limiter (100 MHz to 12.4 GHz, usable to 18 GHz) guards against input signals over 1 mW up to 1 W average power and 10 W peak power.

**11694A 75  $\Omega$  Matching Transformer**

From 3 to 500 MHz, this transformer allows measurements in 75  $\Omega$  systems while retaining amplitude calibration with a 50  $\Omega$  spectrum analyzer input. VSWRs are less than 1.2; insertion loss is less than 0.75 dB.

**86205A and 86207A RF Bridges**

These bridges combine the directivity and broadband frequency range of directional bridges with the low insertion loss and flat coupling factor of directional couplers. Directivity is 40 dB, and the wide RF frequency ranges are 300 kHz to 6 GHz for the 50  $\Omega$  86205A and 300 kHz to 3 GHz for the 75  $\Omega$  86207A. Low insertion loss is nominally  $\pm 1.5$  dB. Frequency response of the coupled arm is within  $\pm 0.2$  dB of the nominal 16 dB value. The RF bridges are ideal for use with spectrum analyzers, scalar network analyzers and vector network analyzers.

**41800A Active Probe**

This probe offers high-input impedance from 5 Hz to 500 MHz. It works with many Agilent spectrum analyzers to evaluate the quality of circuits by measuring spurious level, harmonics and noise. Low-input capacitance offers probing with negligible circuit loading for precise, in-circuit measurements of audio, video, HF and VHF bands.

**85024A High-Frequency Probe**

In-circuit measurements are easy with this 300 kHz to 3 GHz probe. Input capacitance of 0.7 pF shunted by 1 M $\Omega$  resistance permits high-frequency probing without adverse loading of the circuit under test. Excellent frequency response and unity gain guarantee highly-accurate swept measurements. High sensitivity and low distortion levels allow measurements that take advantage of full analyzer dynamic range. See page 288.

**Ordering Information**

**85902A** Burst Signal Trigger  
**85671A** Phase Noise Measurement Utility  
**85672A** Spurious Response Measurements Utility  
**85640A** Portable Tracking Generator  
**8447A** Preamplifier (100 kHz to 400 MHz)  
**8447D** Preamplifier (100 kHz to 1.3 GHz)  
**8449B** Preamplifier  
**87405A** Preamplifier  
**85901A** Portable AC Power Source  
**11867A** RF Limiter  
**11693A** Microwave Limiter  
**41800A** Active Probe  
**11694A** 75  $\Omega$  Matching Transformer  
**85024A** High-Frequency Probe  
**86205A** RF Bridge (50  $\Omega$ )  
**86207A** RF Bridge (75  $\Omega$ )  
**85629B** Test and Adjustment Module  
**83050A** 2 to 50 GHz Power Preamplifier  
**83051A** 45 MHz to 50 GHz Preamplifier

- RF power: digital power meter accuracy
- Tuned RF level: 0 to -127 dBm dynamic range
- Carrier noise: AM and phase noise measurements to -140 dBc/Hz
- AM and FM: 1% accuracy;  $\emptyset$ M: 3% accuracy
- RF frequency: 10 Hz resolution
- Audio: level, frequency, and distortion



8902A

## 8902A Measuring Receiver



The 8902A measuring receiver combines 6 precise measurement functions into one fully automatic, GPIB programmable instrument. It accurately measures RF power, tuned RF level, carrier noise/adjacent channel power, modulation, and RF frequency, and it characterizes audio signals. For precise signal analysis, the 8902A measuring receiver provides the performance you need.

### Metrology and Calibration

The 8902A measuring receiver makes signal generator and attenuator calibration easier than ever before. The 8902A provides exceptional accuracy, wide dynamic range, and a broad range of measurements.

It quickly and accurately measures your signal generator's RF frequency, RF level flatness, output level accuracy to -127 dBm, AM and FM with 1% accuracy, incidental and residual AM, FM and phase modulation, and carrier noise down to -140 dBc/Hz, and characterizes the demodulated audio signals.

For attenuator calibration and other relative measurements, the 8902A gives you great accuracy and dynamic range. Option 050 provides  $\pm(0.015 \text{ db} + 0.005 \text{ dB}/10 \text{ dB})$  relative power accuracy to test attenuators to the most stringent specifications.

### RF Signal Characterization

The 8902A measuring receiver is an excellent lab and production tool for accurately characterizing RF signals from 150 kHz to 1300 MHz.

Level measurements down to -127 dBm with superb accuracy make the 8902A ideal for testing devices such as multiplexers, log/linear amplifiers, filters, and mixers. Unlike diode detectors, the 8902A's power meter accurately measures signals with harmonics and spurious.

The 8902A makes accurate AM-to- $\emptyset$ M and FM-to-AM conversion measurements of phase- and amplitude-sensitive devices, such as bandpass filters and multiple-channel receivers. Excellent isolation between AM and FM makes it simple to separate the AM and  $\emptyset$ M of AM stereo, the incidental AM of FM transmitters, and the AM, FM, and  $\emptyset$ M components of complex signals.

### Automatic Test Systems

The 8902A is an important component of automatic RF test systems. All functions—power, level, frequency count, carrier noise, modulation, audio analysis—are fully automatic and easily programmed. With these measurements combined in one instrument, interfacing requirements, hardware costs, and software development time are reduced.

### 8902A Specifications

#### RF Power (with 11722A Sensor Module)

**Range:** +30 dBm (1W) to -20 dBm (10  $\mu$ W)  
**Frequency Range:** 0.1 MHz to 2.6 GHz  
**Linearity:**  $\pm 0.02 \text{ dB}$  (within range)  $\pm 0.02 \text{ dB}$  per range change from reference range  $\pm 1$  count LSD  
**Input SWR:** < 1.15

#### Tuned RF Level

**Range:** 0 to -127 dBm  
**Frequency Range:** 2.5 to 1300 MHz  
**Relative Accuracy:**  $\pm 0.02 \text{ dB} \pm 0.02 \text{ dB}$  per IF range change  $\pm 0.04 \text{ dB}$  per RF range change  $\pm 1$  digit  
**Worst-Case Cumulative Relative Power Accuracy** (with Option 050<sup>1,2</sup>):  
 $\pm 0.005 \text{ dB}/10 \text{ dB}$  step (0 to -100 dBm)  
 $\pm 0.050 \text{ dB}/10 \text{ dB}$  step (-100 to -120 dBm)  
 $\pm 0.015 \text{ dB} \pm 1$  digit

#### Selective Power Measurements (Carrier Noise, Options 030 to 037)

**Frequency Range:** 10 to 1300 MHz  
**Carrier Power Range:**  
 +30 dBm to -20 dBm: 12.5 kHz, 25 kHz and 30 kHz filters  
 $\pm 30 \text{ dBm}$  to -10 dBm: carrier noise filter  
**Relative Measurement Accuracy:**  
 $\pm 0.5 \text{ dB}$ ; levels > -95 dBc: 12.5 kHz, 25 kHz and 30 kHz filters  
 $\pm 0.5 \text{ dB}$ ; levels > -129 dBc/Hz: carrier noise filter  
**Filter Bandwidths:** 2.5 kHz, carrier noise filter; 8.0 kHz, 12.5 kHz filter; 16.0 kHz, 25 kHz filter; 30.0 kHz, cellular radio filter

#### RF Frequency

**Range:** 150 kHz to 1300 MHz  
**Maximum Resolution:** 10 Hz

#### Amplitude Modulation

**Rates:** 20 Hz to 100 kHz  
**Depths:** To 99%  
**Accuracy:**  $\pm 1\%$  of reading  $\pm 1$  digit, for rates 50 Hz to 50 kHz and depths  $\geq 5\%$

#### Frequency Modulation

**Rates:** 20 Hz to 200 kHz  
**Deviations:** To 400 kHz  
**Accuracy:**  $\pm 1\%$  of reading  $\pm 1$  digit, for rates 50 Hz to 100 kHz

#### Phase Modulation

**Rates:** 200 Hz to 20 kHz  
**Deviations:** To 400 radians  
**Accuracy:**  $\pm 3\%$  of reading  $\pm 1$  digit

#### Audio Level, Frequency, and Distortion Capability

**Audio Level Accuracy:**  $\pm 4\%$  of reading, 100 mV to 3 V  
**Audio Frequency Display Resolution:** 6 digits, to 250 kHz  
**Audio Distortion Accuracy:**  $\pm 1 \text{ dB}$ , 400 Hz and 1 kHz

<sup>1</sup> Specifications are warranted when using an Agilent Technologies synthesized source with less than 100 Hz peak residual FM measured in a 3 kHz post-detection bandwidth over a 30-second period.

<sup>2</sup> Accuracy specifications do not include mismatch uncertainty.



8902A  
11812A  
11722A  
11792A  
11793A

### Ordering Information

#### 8902A Measuring Receiver

- Opt 001** Rear-Panel Instead of Front-Panel Connectors for Input, Modulation Output, and Calibrators
- Opt 002** 1x10<sup>-9</sup>/Day Internal Reference Oscillator
- Opt 003** Rear-Panel External LO Connectors
- Opt 004** Operation from 48 to 440 Hz Power Line (temp. < 40° C)
- Opt 021** Add 11722A Sensor Module
- Opt 030** High Selectivity (select only two filter options) Options 032 to 037 require Option 030. Option 030 includes Option 003 connections for external local oscillator.
- Opt 032** 12.5 kHz Filter
- Opt 033** 25.0 kHz Filter
- Opt 035** Cellular Radio Filter
- Opt 037** Carrier Noise Filter
- Opt 050** Increased Power Measurement Accuracy
- Opt 907** Front Handle Kit (5061-9690)
- Opt 908** Rack Flange Kit (5061-9678)
- Opt 909** Rack Flange Kit (5061-9684) with Front Handles
- Opt 910** Additional Operation and Calibration Manual, p/n 08902-90029 and 2 Service Manuals, p/n 08902-90031
- Opt 915** Add Service Manual, p/n 08902-90031
- Opt W30** Extended Repair Service
- Opt W32** Calibration Service

 Indicates QuickShip availability.



11812A

#### 11812A Verification Kit

The 11812A verification kit is available to verify the performance of the 8902A Option 050 tuned RF level function to  $\pm(0.015 \text{ dB} + 0.010 \text{ dB}/10\text{dB step})$ . The kit consists of a step attenuator, two 10 dB pads semi-permanently attached, a cable, and a case.

#### 11812A Specifications

**Frequency:** 30 MHz

**11812A Accuracy:**  $\pm(0.003 \text{ dB} + 0.003 \text{ dB}/10 \text{ dB step})$

**Option 050 Worst-Case Cumulative Tuned RF Level Accuracy Verified with the 11812A:**

- $\pm 0.010 \text{ dB}/10\text{dB step} (0 \text{ to } -100 \text{ dBm})$
- $\pm 0.050 \text{ dB}/10 \text{ dB step } (-100 \text{ to } -120 \text{ dBm})$
- $\pm 0.015 \text{ dB } \pm 1 \text{ digit}$

### Ordering Information

**11812A** Verification Kit

#### 11722A Sensor Module (100 kHz to 2.6 GHz)<sup>1</sup>

The 11722A sensor module was designed for use with the 8901B modulation analyzer and the 8902A measuring receiver. The 11722A contains a silicon monolithic thermocouple as a power-sensing element.

With the 11722A sensor module, you get all the performance of the 8901B or 8902A, plus superb power-measurement accuracy, at a single connector. You can characterize a signal without switching back and forth between the power sensor and the analyzer's RF input.

### Ordering Information

**11722A** Sensor Module (100 kHz to 1300 MHz)

#### Extend the 8902A to Microwave with the 11792A and 11793A Converter



11792A and 11793A

The 11793A microwave converter and the 11792A sensor module combined with an external signal generator extends the 8902A's measurement range into the microwave region. They allow the 8902A to deliver accuracy and resolution of a high performance power meter up to 26.5 GHz from +30 to -100 dBm. The extended system counts signals to 26.5 GHz with 10 Hz resolution and excellent long-term frequency stability.

#### 11793A Microwave Converter

The 11793A microwave converter downconverts microwave signals to the frequency range of the 8902A measuring receiver. For signals above 1.3 GHz, the 11793A routes the signal through its internal mixer. Below 1.3 GHz, signals are routed directly to the input of the 8902A. The 11793A requires an external signal generator with +8 dBm leveled output. For signal generators with insufficient power above 18 GHz, the 11793A offers an optional 18 to 25.5 GHz amplifier to provide the necessary mixer drive.

#### 11792A Sensor Module (50 MHz to 26.5 GHz)<sup>1</sup>

The 11792A sensor module offers superb power-measurement accuracy at a single connector. You can characterize a signal without manually switching between the power sensor and the receiver input.

### Ordering Information

**11793A** Microwave Downconverter

- Opt 001** Add 18 to 26.5 GHz Amplifier
- Opt 010** Front Right LO Input Connector
- Opt 011** Amplifier and Front Right LO Connector
- Opt 020** Rear-Panel Connector
- Opt 021** Amplifier and Rear-Panel Connector
- Opt 907** Front Handle Kit (5062-3988)
- Opt 908** Rackmount Flange Kit (5062-3974)
- Opt 909** Handles w/Rackmount Flange Kit (5062-3975)

**11792A** Sensor Module (50 MHz to 26.5 GHz)<sup>1</sup>

<sup>1</sup> Each 11722A and 11792A sensor module is individually calibrated, traceable to the U.S. National Institute of Standards and Technology. The calibration factors are printed on the sensor module for fast reference. Enter these factors into the 8902A's non-volatile memory and the instrument automatically compensates for the power sensor's efficiency and mismatch loss at each frequency.



- Measures AM and FM to 1% accuracy
- Measures RF frequency
- Measures RF power
- Low internal noise
- Completely automatic



8901B

### 8901B Modulation Analyzer



The Agilent Technologies 8901B modulation analyzer combines the capabilities of several RF instruments to give complete, accurate characterization of modulated signals in the 150kHz to 1000MHz frequency range. The 8901B performs accurate modulation measurements, recovers the modulation signal, determines RF frequency, and measures RF power. It can count audio frequencies and measure distortion on 400 Hz and 1 kHz signals and makes adjacent-channel power measurements or carrier-noise measurements (with Option 030 through Option 037). The 8901B is fully automatic and can make all measurements at the press of a key or under GPIB control.

#### Transmitter Testing

The 8901B has the features to perform standard transmitter measurements. It can perform transmitter power measurements, count frequency, accurately measure signal modulation, and characterize the demodulated signal's audio frequency, level, and distortion. With Option 030 the 8901B can quickly and accurately make adjacent-channel power measurements to CEPT standards.

#### RF Signal Characterization

The 8901B is an excellent lab or production tool for accurately characterizing RF signals. Use the 8901B to make accurate AM/FM and FM/AM conversion measurements of phase- and amplitude-sensitive devices such as bandpass filters and multiple-channel receivers. Excellent isolation between AM and FM make it simple to separate the AM and FM of AM stereo, the incidental AM of FM transmitters, and the AM, FM, and FM components of complex signals.

#### Automatic Test Systems

The 8901B is an important component of automatic RF test systems. All functions are fully automatic and easily programmed. With these measurements combined into one instrument, interfacing requirements, hardware costs, and software-development time are reduced.

#### 8901B Specifications

##### RF Input

**Frequency Range:** 150 kHz to 1300 MHz

**Operating Level:** 12 mV rms to 7 V rms

**Input Impedance:** 50  $\Omega$  nominal

**Tuning:** Manual frequency entry, automatic, or track

**Acquisition Time** (automatic operation): ~1.5 s

**Maximum Safe Input Level** (typical): 35 V rms (25 W for source SWR <4), ac; 40 V, dc

##### Frequency Modulation

**Rates:** 20 Hz to 200 kHz

**Deviations:** To 400 kHz

##### Accuracy:

$\pm 2\%$  of reading  $\pm 1$  digit, 20 Hz to 10 kHz rates, 250 kHz to 10 MHz;

$\pm 1\%$  of reading  $\pm 1$  digit, 50 Hz to 100 kHz rates, 10 to 1300 MHz

**Demodulated Output Distortion:** <0.1% THD

**AM Rejection** (for 50% AM at 400 Hz and 1 kHz rates): <20 Hz peak deviation measured in a 50 Hz to 3 kHz BW

**Residual FM** (50 Hz to 3 kHz BW): <8 Hz rms @ 1300 MHz, decreasing linearly with frequency to <1 Hz rms for 100 MHz and below

**Maximum Deviation Resolution:** 1 Hz

**Stereo Separation** (50 Hz to 15 kHz): >47 dB typical

##### Phase Modulation

**Carrier Frequency:** 10 to 1300 MHz

**Rates:** 200 Hz to 20 kHz; typically usable from 20 Hz to 100 kHz with degraded performance

**Deviation:** To 400 radians

**Maximum Deviation Resolution:** 0.001 radian

**Accuracy:**  $\pm 3\%$  of reading  $\pm 1$  digit

**Demodulated Output Distortion:** <0.1% THD

**AM Rejection** (for 50% AM at 1 kHz rate): <0.03 radian peak deviation (50 Hz to 3 kHz BW)

##### Amplitude Modulation

**Rates:** 20 Hz to 100 kHz

**Depth:** To 99%

##### Accuracy

$\pm 2\%$  of reading  $\pm 1$  digit, 50 Hz to 10 kHz rates, 150 kHz to 10 MHz;

$\pm 1\%$  of reading  $\pm 1$  digit, 50 Hz to 50 kHz rates, 10 to 1300 MHz

**Flatness** (variation in indicated AM depth for constant depth on input signal):  $\pm 0.3\%$  of reading  $\pm 1$  digit

**Demodulated Output Distortion:** <0.3% THD

**FM Rejection** (at 400 Hz and 1 kHz rates, 50 Hz to 3 kHz BW): <0.2% AM

**Residual AM** (50 Hz to 3 kHz BW): <0.01% rms

**Maximum Depth Resolution:** 0.01%

##### Frequency Counter

**Range:** 150 kHz to 1300 MHz

**Accuracy:**  $\pm 3$  counts of least significant digit  $\pm$  reference accuracy

##### Internal Reference

**Frequency:** 10 MHz

**Aging rate:** <1  $\times 10^{-6}$ /month (optional: 1  $\times 10^{-9}$ /day)

**Maximum Resolution:** 1 Hz

8901B

5

8901B  
11715A**RF Level (True RMS)****Frequency Range with 11722A:** 100 kHz to 2.6 GHz**Power Range:** -20 to +30 dBm**RF Range-to-Range Change Error:**  $\pm 0.02$  dB/RF range change from reference range**Input SWR:** <1.15, using 11722A sensor module**Zero Set** (digital settability of zero):  $\pm 0.5\% \pm 1$  digit of full scale on lowest range (decrease by a factor of 10 for each high range)**RF Power Resolution:** 0.1% of full scale in watts or volts mode; 0.001 in dBm or dB relative mode**Selective Power Measurements (Options 030 through 037)****Frequency Range:** 10 MHz to 1.3 GHz**Carrier Power Range:** +30 to -20 dBm, 12.5, 25 and 30 kHz filters; +30 to -10 dBm, carrier noise filter**Dynamic Range:** 115 dB**Carrier Rejection** (temp.  $\leq 35^\circ\text{C}$ ): >90 dB for offsets  $\geq 1$  channel spacing or 5 kHz, whichever is larger**Relative Accuracy:**  $\pm 0.5$  dB, levels  $\geq -95$  dBc or levels  $\geq -129$  dBc/Hz**Power Reference****Power Output:** 1.00 mW, factory set to  $\pm 0.7\%$ , traceable to

the U.S. National Institute of Standards and Technology

**Accuracy:**  $\pm 1.2\%$  worst case ( $\pm 0.9\%$  rss) for one year ( $0^\circ$  to  $55^\circ\text{C}$ )**Audio Filters****High-Pass** (3 dB cutoff frequency): 50 Hz and 300 Hz**Low-Pass** (3 dB cutoff frequency except >20 kHz filter): 3 kHz, 15 kHz, >20 kHz**De-emphasis Filters:** 25  $\mu\text{s}$ , 50  $\mu\text{s}$ , 75  $\mu\text{s}$ , and 750  $\mu\text{s}$ **Calibrators (Standard 8901B)****AM Calibrator Depth and Accuracy:** 33.33% depth, nominal; internally calibrated to an accuracy of  $\pm 0.1\%$ **FM Calibrator Deviation and Accuracy:** 34 kHz peak deviation, nominal; internally calibrated to an accuracy of  $\pm 0.1\%$ **General Characteristics****Operating Temperature Range:**  $0^\circ$  to  $55^\circ\text{C}$ **Power Requirements:** 100, 120, 220, or 240 V (+5%, -10%); 48 to 66 Hz; 200 VA max.**Size:** 190 mm H x 425 mm W x 551 mm D (7.5 in x 16.8 in x 21.7 in)**Weight:** Net, 23 kg (52 lb); shipping, 31 kg (69 lb)**Ordering Information****8901B Modulation Analyzer<sup>1</sup>****Opt 021** Add 11722A Sensor Module**Opt 030** High Selectivity (select only 2 filter options)

(Options 032 through 037 require Option 030; Option 030 includes Option 003 connections for external local oscillators)

**Opt 032** 12.5 kHz Adjacent Channel Filter**Opt 033** 25.0 kHz Adjacent Channel Filter**Opt 035** 30.0 kHz Adjacent Channel Filter**Opt 037** Carrier Noise Filter**Opt 910** Two Sets of Operation/Calibration, p/n

08901-90113 and Service Manuals, p/n 08901-90114

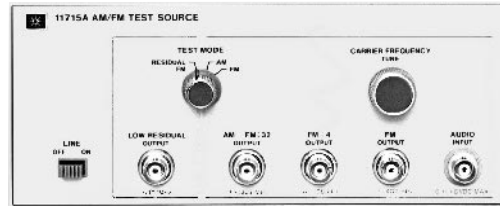
**Opt 915** Service Manual, p/n 08901-90114**Opt W30** Extended Repair Service**Opt W32** Calibration Service<sup>1</sup> GPIB cables not included.

11715A

**11715A AM/FM Test Source**

The 11715A AM/FM test source provides very flat, wide-bandwidth, and low-distortion amplitude- or frequency-modulated RF signals. Designed primarily for performance tests and adjustments of the 8901B modulation analyzer and 8902A measuring receiver, it will also serve as a high-quality modulated test oscillator where its frequency ranges apply.

The major components of the 11715A are a low-noise voltage-controlled oscillator (VCO), 2 digital dividers, and a double-balanced mixer. The VCO is the primary signal source, with a typical frequency range of 330 to 470 MHz at the FM output. FM is produced by directly coupling the external modulation source to the VCO's tune input, providing very wide bandwidth modulation with low phase shift. This design also ensures very little incidental AM.

The 11715A can also be used in conjunction with an 8901B or 8902A or as a calibrated signal source for special applications. In particular, the U.S. commercial FM broadcast band of 88 to 108 MHz is covered by the FM  $\div$  4 output of the 11715A.

**11715A Specifications****FM Outputs****Frequency Range:**

11 to 13.5 MHz, AM FM 4 32 output

88 to 108 MHz, FM  $\div$  4 output

352 to 432 MHz, FM output

**Peak Deviation:**

&gt;12.5 kHz, 11 to 13.15 MHz carrier

&gt;100 kHz, 88 to 108 MHz carrier

&gt;400 kHz, 352 to 432 MHz carrier

**Distortion:** <0.025% THD (<-72 dB) for

Carrier frequency	Peak deviation	Modulation rate
12.5 MHz	12.5 kHz	<10 kHz
100 MHz	100 kHz	<100 kHz
400 MHz	400 kHz	<100 kHz

**Flatness:**  $\pm 0.1\%$ , dc to 100 kHz rates  $\pm 0.25\%$ , dc to 200 kHz rates**Stereo Separation** (88 to 108 MHz carrier, 75 kHz peak deviation, 1 kHz rate): >60 dB typical**AM Output****Frequency Range** (AM/FM  $\div$  32 output): 11 to 13.5 MHz**Depth:** To 99%**Distortion:**

&lt;0.05% THD (&lt;-66 dB), 50% AM, 20 Hz to 100 kHz rates

&lt;0.1% THD (&lt;-60 dB), 95% AM, 20 Hz to 100 kHz rates

**Flatness:**  $\pm 0.1\%$ , 50 Hz to 50 kHz rates;  $\pm 0.25\%$ , 20 Hz to 100 kHz rates**Linearity:**  $\pm 0.1\%$ , <95% AM;  $\pm 0.2\%$ , <99%**Ordering Information****11715A AM/FM Test Source****Opt 910** A Total of Two Sets of Operating and Service Manuals, p/n 11715-90004

Indicates QuickShip availability.

- High performance microwave spectrum analysis
- High performance vector signal analysis
- 71910 plus 89410/89610 based systems
- Spectrum analysis 100 Hz to 40 GHz
- 100 MHz bandwidth on the 89410A/89610A
- Digital modulation analysis and EVM

71000E  
Series  
Custom  
Systems

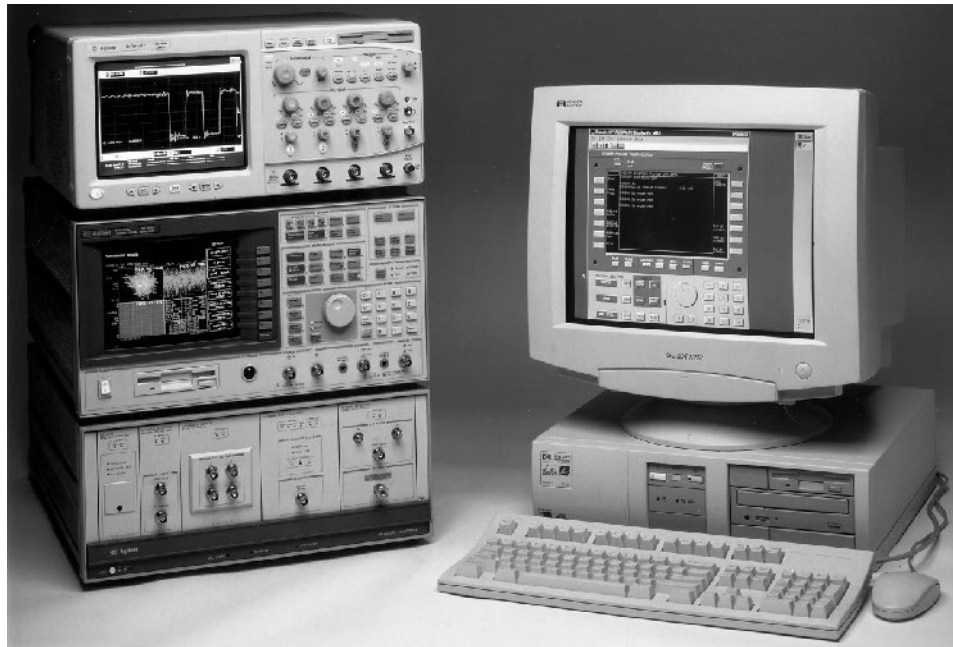

Wide Bandwidth Signal Analysis System

### R&D Tool for Today's Modern Signals

Many of today's wide bandwidth applications require signal analysis capability for both carrier parameter measurements and modulation quality measurements. Applications in microwave wireless include LMDS, W-CDMA and broadband satellite systems.

### 100 MHz Bandwidth on the 89410A/89610A

The Agilent 71000E series wide bandwidth signal analyzer systems are high performance custom systems designed to measure RF and microwave signals, such as those used in many wireless communication systems. The flexible architecture includes the 71910 wideband receiver and the 89410A/89610A vector signal analyzer. This combination provides high performance microwave spectrum analysis together with high performance digital modulation analysis (in custom system configurations providing 100 MHz of information bandwidth on the 89410A/89610A).

### Full Measurement Capability

The 71000E series offers the following features:

- Frequency coverage from 100 Hz to 26.5 GHz, extendable to 40 GHz and higher with external mixers
- Information bandwidths of 100 MHz
- Full 89410A/89610A vector signal analyzer capability
- Custom system specified to your application needs

### Key Literature

100 MHz Bandwidth Microwave Vector Signal Analysis, p/n 5968-0123E

### A Modular, Reusable Architecture

The 71000E series wide bandwidth signal analyzer systems use the industry standard 89410A/89610A vector signal analyzer as the measurement engine for the advanced analysis of complex signals. The 71910 provides flexible, high-performance spectrum analysis on the RF and microwave carrier, including out-of-band performance, interference and spurious signal measurements. It also provides wide bandwidth IF output to the 89410A/89610A or to an 54845A infinium oscilloscope.

Adding the 54845A infinium oscilloscope as a high-speed digitizer provides the 100 MHz wide bandwidth signal capture. The 100 MHz bandwidth signals are ported to the 89410A/89610A for complex signal analysis, providing true 100 MHz information bandwidth signal analysis on the 89410A/89610A. The 71910, 89410A/89610A and 54845A are all usable individually, providing maximum flexibility and protecting your investment in measurement assets.

### Calibration Software and Customization

System calibration software is a key feature of all 71000E series wide bandwidth signal analyzers. Specifications are provided for each custom application, and individual instruments are programmable via GPIB. Custom application software is also available. In addition, Agilent will develop, procure and integrate specialized signal routing and signal conditioning as well as other customized equipment to optimize the system for your needs.

### Ordering Information

71000E Series Custom Systems

For more information, please contact the Agilent Call Center in your region.

89600 Series

- 36 MHz bandwidth (89640A), 39 MHz bandwidth (89610A)
- PC based software in Windows NT
- Vector Modulation Analysis (optional)
- 192 Msamples memory (optional)
- VXI based hardware
- 100 Msamples/sec, 12 bit digitizer
- Links to Agilent's Advanced Design System (optional)
- 78 MHz bandwidth in I + jQ mode with 2nd Channel (optional)
- 100k point FFT
- Built-in math functions

### 89600 Series Vector Signal Analyzers

The new 89600 Series VSA combines frequency domain, time domain, and modulation domain analysis to provide you with the set of measurement tools you need in today's fast moving digital communications market, especially wideband formats such as those found in LMDS, wireless LAN, and other broadband systems.

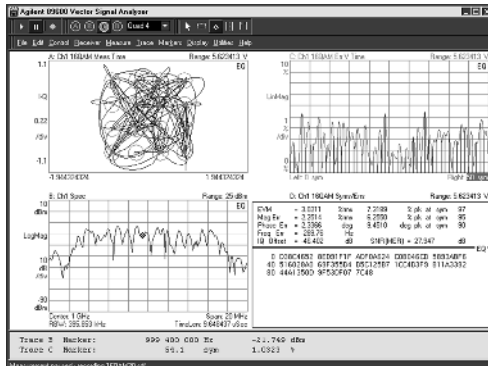

16 QAM 20 MHz bandwidth signal

Agilent Technologies offers two systems, 89610A, DC to 40 MHz, and 89640A, DC to 2.7 GHz, each in a compact 4-slot mainframe.

Measurements are made on baseband, IF, or RF signals, with a wide selection of modulation formats (BPSK, QPSK, OQPSK, DQPSK,  $\pi/4$ DQPSK, 2FSK, 4FSK, 8PSK, 16QAM, 32QAM, 64QAM, 256QAM and much more), variable symbol rates, and a variety of filters. Display your measurement results using constellation, eye, trellis, spectrum, or time formats.

### Links to Advanced Design System

The VSA's tight linkages to Agilent's Advanced Design System (ADS) electronic design automation software means you can use the same tools throughout the design and development phases of your product. Evaluate computational data from simulations as well as measured data from your prototypes using the dynamic link between the 89600 series and ADS EDA software.

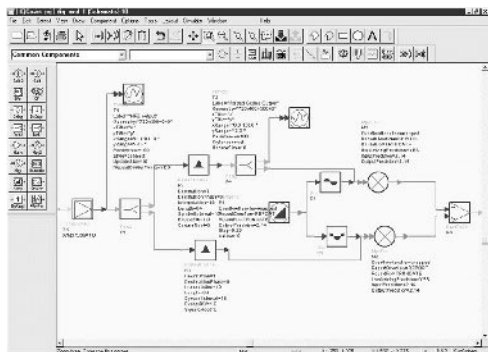

Advanced Design System simulation with 89600 series performing the measurements

### Signal Quality Measurements

Using EVM (error vector magnitude) versus time measurements, you can uncover problems with carrier frequency, symbol clock, filtering, and other DSP problems. Identify unwanted signals in modulated carriers such as switcher power supply noise or signals from other parts of the system coupling in, using EVM spectrum.

### Compensating for Linear Errors

The power of the vector signal analyzer is its ability to analyze the quality of a signal and correct for linear errors. Adaptive equalization removes linear errors from I/Q modulated signals by dynamically creating and applying a compensation filter.

### AM, FM, and PM Modulation

Analyze signals for instantaneous amplitude, frequency, or phase versus time. Characterize phase noise, oscillator frequency transitions, and transmitter turn-on behavior.

### Flexible Triggering, and Gating

The 89600 series has extremely flexible triggering, which you can set on a particular amplitude or adjust the delay to positive or negative.

Analyze individual bursts using the gating feature. Simply place the gate bars around the burst you wish to analyze and the VSA will perform an FFT for that portion of the burst.

### Peak/Average Measurements

Perform statistical measurements of peak, average, and peak-to-average power including complementary cumulative distribution function (CCDF).

### Measurement Automation

Since the 89600 series measurement software is PC-based, automating measurements is made easy. The 89600 series provides an application programming interface to the component object model or COM API. There are two COM APIs: VsaVector, and VsaScalar. These APIs allows C++ and Visual Basic programs access to all measurement, computational, and display features of the 89600 series VSA.

For those who wish to record key-strokes or mouse clicks, it's easy to create user defined macros from the utilities menu.

### 89610A Baseband Vector Signal Analyzer

This system is a DC to 40 MHz VSA with a bandwidth of 39 MHz. The system consists of the following modules:

- E8408B (option 001) VXI mainframe
- E8491B (option 001) IEEE 1394 controller/interface
- E1438A 100 MS/sec ADC
- 89606A Input/calibration module
- 89601A Option 100 vector signal analyzer software

A second ADC channel can be added (Option 102) giving an effective bandwidth of 78 MHz for I + jQ measurements.

89610A options

- Opt 144 (144 Mbytes memory)
- Opt 288 (288 Mbytes memory)
- Opt 102 (add 2nd channel)
- Opt 105 Dynamic link to EESof/ADS
- Opt 145 (2nd ch w/144 Mbytes)
- Opt 289 (2nd ch w/288 Mbytes)
- Opt AYA (add Vector Modulation Analysis)



**89640A RF Vector Signal Analyzer**

This system is a DC to 2.7 GHz VSA with a bandwidth of 36 MHz. The system consists of the following modules:

E8408B w/001 VXI mainframe  
E8491B/001 IEEE-1394 controller/interface  
E2730 2.7 GHz RF tuner  
E1439A 100 MS/sec ADC  
89605A Input/Calibration board  
89601A Option 100 Vector Signal Analyzer Software

**89640A Options:**

Opt 144 (add 144 MBytes memory)  
Opt 288 (add 288 Mbytes memory)  
Opt AYA (Vector Modulation Analysis)  
Opt 105 Dynamic link to EESof/ADS

**Specifications:**

	<b>89610A</b>	<b>89640A</b>
<b>Frequency range</b>	DC to 40 MHz	DC to 2.7 GHz In 2 ranges: DC to 36 MHz and 36 MHz to 2.7 GHz
<b>Frequency span</b>		
Scalar	1 Hz to 39 MHz	1 kHz to 2.7 GHz
Vector	1 Hz to 39 MHz	1 Hz to 36 MHz
<b>Center frequency resolution</b>	0.001 Hz	0.001 Hz
<b>Resolution bandwidth</b>	1 Hz to 3 MHz	1 Hz to 10 MHz
<b>Phase noise</b>	-108 dBc/Hz (100 Hz offset) <sup>1</sup> -118 dBc/Hz (1 kHz offset) <sup>1</sup>	<-97 dBc/Hz (20 kHz) <sup>2</sup> -112 dBc/Hz (20 kHz) <sup>2</sup>
<b>Amplitude specifications</b>		
Input range	-31 dBm to +20 dBm	-45 dBm to +20 dBm
<b>Maximum power</b>	+24 dBm	+20 dBm
<b>VSWR</b>	1.33:1 (17 dB return loss)	2.5:1 (7.3 dB return loss)
Amplitude accuracy is the sum of full-scale accuracy and amplitude linearity.		
<b>Full-scale accuracy</b>		
20° C to 30° C	+/-0.7 dB	+/-2 dB
0° C to 55° C	+/-0.7 dB	+/-2 dB typical
<b>Amplitude linearity</b>		
0 to -30 dBfc	+/-0.1 dB	+/-0.1 dB
-30 to -50 dBfc	+/-0.15 dB	+/-0.15 dB
-50 to -70 dBfc	+/-0.2 dB	+/-0.2 dB
<b>3rd order intermodulation</b>	<-70 dBc	<-70 dBc
<b>Residual responses</b>	<-100 dBm	<-100 dBm
<b>Sensitivity</b>	-152 dBm/Hz	-159 dBm/Hz
<b>Error vector magnitude</b>		
Span <100 kHz	<0.5 % rms	<0.5 % rms
Span <1 MHz	<0.5 % rms	<0.5 % rms
Span <10 MH	<1.0 % rms	<1.0 % rms
Span >10 MH	<2.0 % rms	<2.0 % rms

The above specifications apply over the temperature range of 20° C to 30° C.

<sup>1</sup>10 MHz input

<sup>2</sup>1 GHz input

**Key Literature****Ordering Information****89610A**

**Opt 144** (144 Mbytes memory)  
**Opt 288** (288 Mbytes memory)  
**Opt 102** (add 2nd channel)  
**Opt 105** Dynamic link to EESof/ADS  
**Opt 145** (2nd ch w/144 Mbytes)  
**Opt 289** (2nd ch w/288 Mbytes)  
**Opt AYA** (add Vector Modulation Analysis)

**89640A**

**Opt 144** (add 144 Mbytes memory)  
**Opt 288** (add 288 Mbytes memory)  
**Opt AYA** (Vector Modulation Analysis)  
**Opt 105** Dynamic link to EESof/ADS

VSA system modules and components can be ordered using the 89600S system.

VXI mainframe selection, choose one of the following with an 89600S system:

**E8408A** with option 001, 918 4-slot portable VXI mainframe  
**E1421B** with option 918 6-slot C size mainframe  
**E8401A** with option 918 13-slot C size mainframe  
**E8402A** with option 918 13-slot C size mainframe, enhanced monitoring  
**E8403A** with option 918 13-slot C size mainframe, high power  
**E8404A** with option 918 13-slot C size mainframe, high power, enhanced monitoring

**89601A VSA Software**

**Opt 100** Vector Signal Analysis  
Includes Asset Control Module for HW  
**Opt AYA** Vector Modulation Analysis  
**Opt 105** Dynamic link to EESof/ADS  
**Opt 110** Upgrade E8844A to 89601A  
Adds ACM for HW.

**E8844A VSA Software for EESof/ADS**

Includes Vector Signal Analysis, Vector Modulation Analysis, and link to ADS. Does not include ACM for HW.

89410A  
89441A  
89441V  
89411A  
89450A  
89451A

- 3GPP (W-CDMA) format now supported (optional) **NEW**
- Innovative ISI compensation for improved EDGE measurements (optional) **NEW**
- Option UTH 20 MB RAM now included free
- Digital modulation analysis now includes adaptive equalization (optional)
- I-Q gain imbal. and quadruple skew now measured for most formats **NEW**
- Simultaneous time and frequency measurements
- Advanced, optimized time-gated spectrum analysis
- Uncover phase, amplitude, and frequency transients
- 1 MSample time capture for post-processing transients (optional)
- High accuracy integrated band power measurements
- Second 10 MHz input channel for I+jQ measurements (optional)
- Flexible internal RF signal source (optional)



89441A DC to 2.65 GHz Vector Signal Analyzer



89410A DC to 10 MHz Vector Signal Analyzer

### 89400 Series Vector Signal Analyzers

#### Advanced Measurements on Complex Signals

Agilent Technologies's Vector Signal Analyzers integrate frequency-domain and time-domain analysis to provide the most advanced measurements of complex and time-varying signals. Using state-of-the-art digitizing and signal processing technology, these analyzers offer complex signal analysis, such as digital modulation analysis and AM/FM/PM demodulation, vector spectrum analysis, and time-gated spectrum analysis. Simultaneous time-domain and frequency-domain measurements and displays improve productivity and enhance ease of use.

The vector signal analyzers are ideally suited for the following technologies:

- RF Communications
- Video Broadcast
- Satellite
- Radar
- Sonar
- Ultrasound Imaging

The 89400 series can easily capture and analyze the burst, pulsed, transient, hopping, analog modulated, and digitally-modulated complex signals from these technologies.

The 89410A covers baseband frequencies from dc to 10 MHz with one or two full-bandwidth input channels. The 89441A covers baseband through RF frequencies of dc to 2.65 GHz, with a single RF input and an (optional) dc to 10 MHz second baseband channel. The 89441V bundles all necessary options for digital video test.

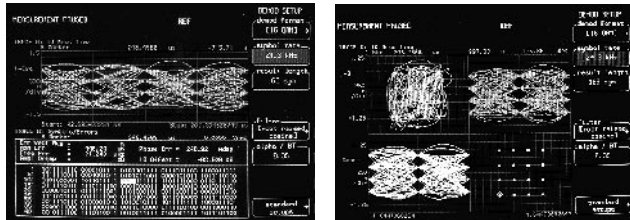

#### Troubleshoot Designs with Digital Modulation Analysis

A vector signal analyzer with optional vector modulation analysis provides all the tools necessary to test and troubleshoot throughout a system block diagram.

Measurements are made on baseband, IF, or RF signals with a selection of modulation formats, variable number of symbols and a variety of filter shapes. A wide range of display formats is available including constellation, eye, or vector diagrams, in addition to numerous error and other signal quality analysis results.

Adaptive equalization removes linear errors from I-Q modulated signals by dynamically creating and applying a compensating filter.

These errors include group delay distortion, frequency response errors (tilt, ripple), and reflections or multipath distortion. Measure impaired channels and isolate linear vs. non-linear error mechanisms. This general purpose equalizer does not require symbol lock or prior knowledge of the signal (such as a training sequence). Added measurement data types include the derived channel frequency response and the impulse (time domain) response of the compensating filter.

Uncover carrier frequency, symbol clock, filtering, and DSP errors with powerful EVM versus time and EVM spectrum displays. Identify noise sources and paths with advanced math analysis. Capture, identify and re-analyze transients with time capture. Share data with Agilent's Advanced Design System simulation software.

New option 080 provides 3GPP (W-CDMA) measurement capability, including code domain power. Enhancements to option B7A provide both new windowed-RC filtering and a patent-pending ISI-compensation technique that provides legible constellation diagrams without compromising signal integrity.

The same tools are available for digital video with Option AYH or 89941V for characterizing both QAM and VSB modulated signals. See page 512 for video applications.

For more information, visit our web site:  
<http://www.agilent.com/find/89400>

#### Precision AM, FM, and PM Demodulation

Precision, high-resolution digitized time-series data allows for advanced signal analysis, such as AM, FM, and PM demodulation. Signals can be analyzed for instantaneous amplitude, frequency, or phase versus time, and the resulting time-domain results can be translated into the frequency domain for further analysis. This is useful for characterizing phenomena such as phase noise, oscillator frequency transients, and the amplitude or frequency behavior of transmitters at turn-on. Both deliberate and unintentional (or incidental) modulation can be characterized completely. Demodulation is selective, so that the type of modulation can be uniquely determined and separated from other types. FM and PM demodulation are made easier with an auto-carrier function.

#### High-Speed, Narrow-Resolution Vector Spectrum

Using high-speed signal processing, these analyzers can measure both the magnitude and phase (in the frequency domain) of CW and nonstationary or burst signals. Multiple-signal processors and micro-processors display signal and circuit behavior in real time, and produce fast averaged measurements with enhanced signal-to-noise ratio.

High-measurement speed is preserved even in narrowband measurements, with display updates orders of magnitude faster than traditional analyzers performing equivalent measurements. Resolution is also better, with resolution bandwidths less than 0.001 Hz over the entire frequency range.

Optional waterfalls display up to 300 successive spectra and scroll them through the display, while spectrograms use colors to indicate signal amplitudes. Both formats make it easy to monitor signal trends of short or long duration.

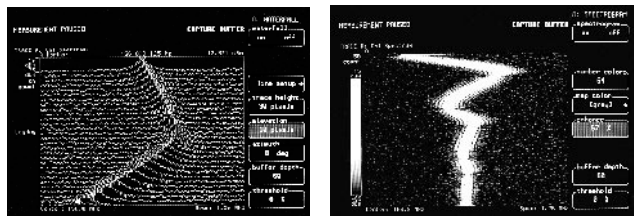

### High-Resolution, High Dynamic Range Time Domain

All measurements are made with a state-of-the-art A/D subsystem and proprietary signal processing. All frequency spans are image and alias protected, offering band-limited time-domain analysis not available in traditional oscilloscopes and waveform analyzers.

These products feature a deep-data memory of up to one million samples (optional). This memory can be used for long duration time capture, where the time-capture data can be selectively post-processed (internally) or transferred via GPIB to an external computer for further analysis.

### Advanced Time-Selective Spectrum Analysis

For burst or time-varying signals, it may be necessary to examine only a selected part of the waveform. Time-selective spectrum analysis in the 89400 Series Vector Signal Analyzers allows the entire time-domain signal to be viewed and a specific portion selected for frequency-domain analysis. The selected data is identified clearly with gate markers and all of its traditional frequency-domain parameters (including noise or signal/noise) can then be measured. In addition, this time-selective analysis does not require a repetitive signal.

### Powerful, Flexible Triggering

These vector signal analyzers have extremely flexible triggering to make the most of their time-selective analysis and demodulation features including IF trigger. The IF trigger allows the analyzer to establish a trigger from a selected frequency band of the input signal, ensuring that the trigger event can always be seen. Both analyzers also provide pre-trigger and post-trigger delays, along with manual, external, or automatic arming with programmable delay.

### Advanced Data Analysis

The high-resolution time-domain data of the 89400 analyzers allows for advanced data analysis functions. The built-in math functions can be used for scalar arithmetic and complex operations. Other advanced analysis capabilities include correlation functions, useful in uncovering hidden periodic signals and analyzing multipath or other signal delays.

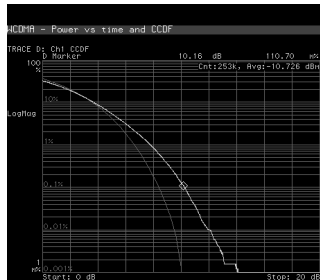

### Statistical Peak/Average Power Measurements

Precision statistical measurements of peak, average, and peak-to-average power including CCDF can now be made automatically. A time domain marker function simplifies measurements by allowing direct entry of the peak percentage and quickly accumulating thousands of measurement samples.

Accurately setting signal levels is simplified by taking advantage of the analyzer's ability to recalculate results using different peak percentages without taking new data. It is even possible to simultaneously display multiple power parameters based on a single block of measured data.

The Complementary Cumulative Distribution Function (CCDF) allows statistical power measurements on noise-like signals. Use it to set amplifier operating points and determine headroom.

### Measurement Automation and Convenience Features

Optional Instrument BASIC (a subset of BASIC) runs inside the analyzers to make repetitive measurements, to create custom displays and test sequences, and even to control other instruments in a test system. Automatic program generation is available with the "key-stroke recording" feature, which creates complete executable programs by remembering keys pressed during an actual measurement.

Adjacent channel power, occupied bandwidth, and modulation accuracy are among the measurements that can be made with the ease of "one-button" setups using the 89451A Radio Test Personality. The measurements can be made on burst or continuous signals of NADC, CDMA, PDC, PHS, or user-defined systems.

### LAN Access and Virtual Front Panel

For remote control from across the building or across the world, the standard unit allows direct transfer of instrument commands and measurement results to a LAN-equipped PC or workstation. Option UG7 adds access to instrument memory and file storage via FTP, along with an X-Windows-based "virtual front panel." This display, which can be sent to an X-compatible server anywhere on your network, shows not only the measurement display, but also the complete instrument front panel. Press keys with your mouse or pointing device, and operate the analyzer just as if it were in front of you.

### 89410A Baseband Vector Signal Analyzer

The 89410A covers a frequency range of dc to 10 MHz and offers an optional second channel. The second channel makes it possible to measure frequency response or perform vector network analysis, and the built-in math functions facilitate measurement calibration and correction.

Two-channel statistical measurements such as cross-correlation and coherence can also be made. Cross-correlation is also useful in analyzing multipath distortions.

Coherence is useful for troubleshooting noise or signal propagation through a circuit or system. It is also a good indication of the quality of a network measurement in a noisy environment.

### Flexible Source

The 89410A provides a flexible source for circuit stimulation. Sine waves, periodic chirps (sine-wave sweeps), and pseudo-random noise are available, along with user-definable arbitrary waveforms. The arbitrary waveforms operate on a block of up to 16,384 complex points.

Any of these signals can be used as a stimulus while spectrum measurements are made elsewhere in the circuit. Source level and dc offset of the pattern are all controllable by the user.

### 89441A RF Vector Signal Analyzers

The 89441A covers baseband through RF frequencies of dc to 2.65 GHz, in scalar and vector analysis modes. The scalar RF instrument mode allows full-frequency coverage in spans to 2648 MHz in the 89441A. Vector RF mode offers exceptional speed and additional signal processing for enhanced time-domain characterization and demodulation. Vector spans as wide as 7 MHz (8 MHz with Option AYH) can be selected anywhere in the 2.65 GHz frequency range. A vector baseband mode is also available to provide all of the features and functionality of the 89410A.

In vector RF mode, both phase and amplitude characteristics are captured in the time-series data. This information can be processed for narrow-resolution spectrum analysis, AM/FM/PM demodulation, time-selective analysis, vector modulation analysis (optional) and many other types of measurements.

89410A  
89441A  
89411A  
89441V  
89450A  
89451A

5

89410A  
89441A  
89441V  
89411A  
89450A  
89451A

### RF Signal Source

In vector RF mode, the 89441A offers an optional flexible source with up to 7 MHz bandwidth, settable to any frequency in the 2.65 GHz frequency range. As with the 89410A, sine waves, periodic chirps (sine-wave sweeps), and pseudo-random noise are available, along with user-definable arbitrary waveforms.

### Microwave Measurements with Downconverter

The 89411A IF downconverter works with the 89410A to provide narrowband vector signal analysis at RF and microwave frequencies. The 89411A converts a 21.4 MHz IF output from an external receiver to the input frequency range of the 89410A. This downconverter is also compatible with the 89441A.

This downconverter is designed for use with various microwave spectrum analyzers and other devices with compatible 21.4 MHz IF outputs. Frequency coverage is thus available over the complete frequency range of the microwave receiver or analyzer.

### Specifications Summary

Refer to the 89410A/89441A/89411A technical data sheets for full specifications. The following specifications apply from 0° C to 55° C.

	89410A	89441A
<b>Frequency</b>		
Frequency range	dc to 10 MHz	2 MHz to 2650 MHz
Frequency span		
Scalar mode	1.0 Hz to 10 MHz	1.0 Hz to 2648 MHz
Vector mode	1.0 Hz to 10 MHz	1.0 Hz to 7 MHz (8 MHz with Option AYH)
Center frequency tuning resolution	0.001 Hz	0.001 Hz
Accuracy-initial	± 10 ppm (± 0.2 ppm optional)	± 0.1 ppm
Resolution bandwidth	312.5 μHz to 3 MHz (1, 3, 10 sequence or arbitrary)	312.5 μHz to 3 MHz (1, 3, 10 sequence or arbitrary)
Phase noise	(at center frequency = 10 MHz)	1000 MHz ≤ center frequency ≤ 2650 MHz
100 Hz offset	-106 dBc/Hz	-87 dBc/Hz
1 kHz offset	-110 dBc/Hz	-97 dBc/Hz
10 kHz offset	-120 dBc/Hz	-116 dBc/Hz (-124 dBc/Hz typ.)
100 kHz offset	-120 dBc/Hz	-116 dBc/Hz
<b>Amplitude</b>		
Input range		
50 Ω	-30 dBm to +24 dBm	-50 dBm to +25 dBm
75 Ω	-31.7 dBm to +22.2 dBm	—
1 M Ω (referenced to 50 Ω)	-30 dBm to +24 dBm	—
Accuracy-absolute full-scale	± 0.5 dB	± 2.0 dB (±0.5 dB typical)
Accuracy-amplitude linearity		—
0 to -30 dBfs	< 0.10 dB	< 0.10 dB
-30 to -50 dBfs	< 0.15 dB	< 0.15 dB
-50 to -70 dBfs	< 0.20 dB	< 0.20 dB
Input noise density (50 Ω)	-114 dBfs/Hz	-112 dBfs/Hz
Sensitivity (lowest range, 50 Ω)	-144 dBm/Hz	-159 dBm/Hz
Spurious responses		
General spurious	≤ -75 dBfs (≥ 1 MHz)	< -70 dBc
Second harmonic distortion	< -75 dBc (-80 dBc typical)	< -75 dBc
Intermodulation (third order relative to two tones at -6 dBfs)	≤ -75 dBc (-85 dBc typical)	< -75 dBc
Residual responses	< -75 dBfs (< 1 MHz) -80 dBfs (≥ 1 MHz)	< -80 dBfs —
<b>Analog demodulation</b>		
Maximum bandwidth (typical)	10 MHz	7 MHz
Demodulation accuracy		
-AM	± 1% (typical)	± 1% (typical)
-PM	± 3 degrees (typical)	± 3 degrees (typical)
-FM	± 1% of span (typical)	± 1% of span (typical)
<b>Trigger</b>		
Scalar mode	Free run, input channel, internal source, GPIB, external	Free run, GPIB, internal source, external
Vector mode	Free run, input channel, IF channel, internal source, GPIB, external	Free run, IF channel, internal source, GPIB, external
<b>Input</b>		
Coupling	dc/ac	ac
<b>Source</b>		
Scalar mode	Fixed sine, arbitrary	—
Vector mode	Fixed sine, random noise, periodic chirp, arbitrary	Fixed sine, random noise, periodic chirp, arbitrary
Arbitrary source	Up to 16,384 – 32,768-real/complex points, depending on span	Up to 16,384 – 32,768-real/complex points, depending on span
Source level (fixed sine)	-110 dBm to +23.9 dBm	-40 dBm to +13 dBm

Note: specifications apply with the RF receiver selected. All 89410A specifications also apply for dc to 10 MHz measurements. RF source optional, 89441A.



**Combined 89410A/89441A Specifications****Two Channel**

Note: Requires second 10 MHz input channel (Option AY7)

**Channel Match: (dc to 10 MHz):**  $\pm 0.25$  dB,  $\pm 2.0^\circ$

**Real-Time Bandwidth**

**Single-Channel Vector Mode Real-Time Bandwidth:** 78.125 kHz (with frequency spans of  $10^{7/2}$  Hz, arbitrary auto-coupled resolution bandwidth, markers off, averaging off, one displayed trace with calculations off on other traces, log-magnitude spectrum measurement, 1601 frequency points, channel 2 off)

**Measurement Speed**

**Vector Mode Maximum Display Update Rate:** 60 traces/second

**Averaging**

**Scalar Mode:** rms (video), rms (video) exponential, peak hold

**Vector Mode:** rms (video), rms (video) exponential, time, time exponential, peak hold

**Number of Averages:** 1 to 99,999

**Time-Gating**

**Minimum Gate Length:** < 400 ns (dependent on span and RBW window selected)

**Time-Capture**

**Time-Capture Memory:** 64 K sample (1 M sample with Option AY9)

**Trace Math**

**Operands:** Measurement data, data register, constant, other trace math functions, j $\oplus$

**Operations:** +, -, x,  $\div$ , cross correlation, conjugate, magnitude, phase, real, imaginary, square root, FFT, inverse FFT, natural logarithm, exponential

**Marker Functions:** Peak signal track, frequency counter, bandpower

**Interfaces:** Active probe power, sync output, external reference input/output, GPIB, RS-232, Centronix, external multi-sync monitor (A second GPIB and LAN interface are now standard.)

**Memory and Data Storage:** Nonvolatile RAM disk (100 KB), volatile RAM disk (20 MB), internal 3.5-inch flexible disk (1.44 MB LIF or DOS format), external disk (GPIB interface)

**Standard Instrument Includes:** Manuals, Standard Data Format Utilities (LIF to DOS conversions, SDF conversions, data and instrument state display, PC-MATLAB and MATRIXx conversions)

**Vector Modulation Analysis (Option AYA)**

**Continuous or TDMA Formats:** BPSK, QPSK, Offset QPSK, DQPSK,  $\pi/4$  DQPSK, 8PSK, 16QAM, 32QAM, MSK, 2 and 4 level FSK

**Digital Video Formats (Option AYH):** 64-256QAM, 8-16VSB

**Data Block Lengths:** Adjustable up to 4096 symbols (2048 symbols max. with Offset QPSK demodulation)

**User Selection of Filters:** Raised cosine, root-raised cosine, IS-95 base phase eq., IS-95 Chebyshev, Gaussian, low pass, user-defined

**Adjustable Alpha (BT):** 0.05 to 100

**Trace and Table Formats:** Constellation, vector diagram, eye diagrams, trellis diagrams, continuous I or Q vs. time, continuous error vector magnitude vs. time, modulation quality summary, detected symbol table

**Analysis Types:** Error vector magnitude, phase error, magnitude error, amplitude droop, carrier frequency error, IQ offset, error vector spectrum, measured IQ spectrum, channel frequency response, impulse response of equalizer filter

**One-Button Measurements (89451A):** Adjacent and alternate channel power, occupied bandwidth, modulation accuracy, power due to modulation (or full signal)

**General Specifications****Environmental**

**Calibration Interval:** 1 year

**Warmup Time:** 30 minutes

**Temperature:** 0° C to 55° C (operating), -20° C to 65° C (not operating)

**Power Requirements**

**115 Vac Operation:** 90 to 140 V rms, 47 to 440 Hz (47 to 63 Hz for 89441A)

**230 Vac Operation:** 198 to 264 V rms, 47 to 63 Hz

**Maximum Power Dissipation:** 750 VA (89410A), 1025 VA (89441A)

**Audible Noise:** LpA  $\leq 50$  dB (89410A),  $\leq 55$  dB (89441A) typical at 25° C

**Physical****89410A:**

Size: 230 mm H x 426 mm W x 530 mm D (9.1 in x 16.7 in x 20.9 in)

Weight: 25 kg (55 lb)

**89441A IF section:**

Size: 230 mm H x 426 mm W x 530 mm D (9.1 in x 16.7 in x 20.9 in)

Weight: 25 kg (55 lb)

**89441A RF section:**

Size: 173 mm H x 419 mm W x 495 mm D (6.8 in x 16.5 in x 19.5 in)

Weight: 25 kg (55 lb)

**89411A 21.4 MHz Downconverter Specifications****Bandwidth**

**With 8566A/B:** Approx. 3 MHz

**With 70902A/70903A:** Approx. 8 MHz

**Power Requirements**

**115 Vac Operation:** 90 to 132 V rms, 47 to 440 Hz

**230 Vac Operation:** 198 to 264 V rms, 47 to 63 Hz

**Maximum Power Dissipation:** 100 VA

**Physical**

**Weight:** 11.1 kg (25 lb)

**Size:** 90 mm H x 426 mm W x 520 mm D (3.5 in x 16.7 in x 20.5 in)

The 89400 Series Vector Signal Analyzers were designed with expandability in mind and the ability to keep up with customers' growing measurement needs. As performance is improved and features added, firmware upgrades are simple using the analyzer's internal disk drive.

Recent new features include:

- Offset QPSK demodulation, CDMA filters, and  $\rho$  (rho) added to Option AYA
- Adaptive equalization added to Option AYA and AYH
- 8 MHz information bandwidth for 89441A via Option AYH
- Peak-to-average power measurements, including CCDF
- Arb waveform block length expanded 4X to 16,384 complex points
- DC offset can be removed in the DC-coupled Ch1 + Ch2 mode
- New EDGE and W-CDMA demodulation options

**Key Literature**

A videotaped demonstration, several Product Notes, and Technical Datasheets are available for the 89400 Series Vector Signal Analyzers. To receive a current literature index and order form via e-mail, send a message containing the single word "89400" to: [lit\\_index@lids.agilent.com](mailto:lit_index@lids.agilent.com) or contact the Agilent Call Center in your region.

**Ordering Information**

**89410A** DC to 10 MHz Vector Signal Analyzer

**89441A** DC to 2.65 GHz Vector Signal Analyzer

**Opt AY4** Delete High-Precision Frequency Reference (89441A only)

**Opt AY5** Precision Frequency Reference (89410A only)

**Opt AY7** Second 10 MHz Input Channel

**Opt AY8** Internal RF Source (89441A only)

**Opt AY9** Extend Time Capture to 1 Msample

**Opt AYA** Vector Modulation Analysis

**Opt AYB** Waterfall and Spectrogram

**Opt AYH** Digital Video Modulation Analysis

**Opt UG7** Advanced LAN Support

**Opt 1C2** Instrument BASIC

**Opt 1D7** 50 to 75  $\Omega$  Minimum Loss Pad (89441A only)

**Opt 1F0** PC-Style Keyboard—U.S. Version

(other options available for German, Spanish, French, U.K., Italian, and Swedish)

**Opt B73** CDP for W-CDMA Experimental System

**Opt B7A** EDGE Modulation Analysis

**Opt B79** ARIB 1.0-1.2 W-CDMA Analysis

**Opt 080** 3GPP W-CDMA Analysis

**89441V** VSB/QAM Signal Analyzer

**89450A** DMCA Radio Test Application Personality

**89451A** Radio Test Personality

**89411A** 21.4 MHz Downconverter

**89431A** 2.65 GHz RF section (converts 89410A to 89441A)

**89400A** +24C User Training (scheduled)

**89400A** +24Y User Training (dedicated)

**E9285A** Opt K01 DVB-T COFDM Measurement Software

4395A

- Full-vector network and spectrum measurement and analysis
- Wide dynamic range network measurement with fast sweep speeds
- $\pm 0.05$  dB /  $\pm 0.3^\circ$  dynamic magnitude/phase accuracy
- Extremely fast narrowband spectrum measurement
- Impedance analysis option and test kit available
- $-145$  dBm/Hz sensitivity for spectrum analysis
- Built-in IBASIC for easy test automation
- Time-gated spectrum analysis option
- Color TFT display and built-in disk drive/RAM disk

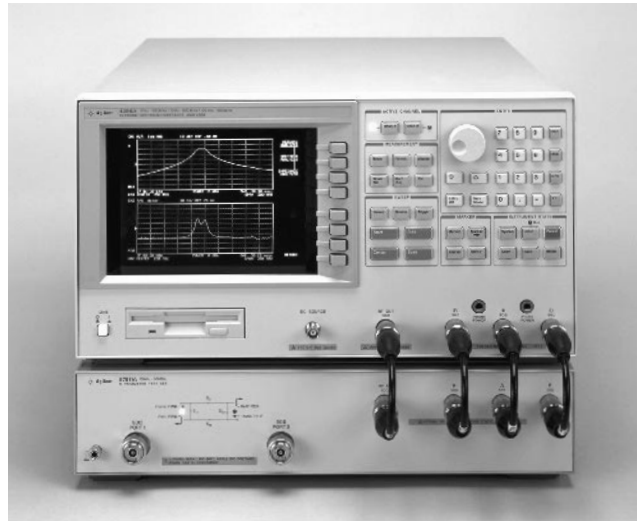

4395A with 87511A

## 4395A Network/Spectrum/Impedance Analyzer

5

The 4395A provides excellent vector network, spectrum and optional impedance measurements for audio, baseband, HF, VHF, and IF applications. Gain, phase, group delay, distortion, spurious, CN ratio, and noise measurements often required for evaluating components and circuits can be measured using one instrument. When combined with a test set, the 4395A provides reflection measurements, such as return loss, and SWR, and S parameters. As a vector network analyzer, the 4395A operates from 10 Hz to 500 MHz with 1 MHz resolution and its integrated synthesized source provides  $-50$  to  $+15$  dBm of output power with 0.1 dB resolution. The dynamic magnitude and phase accuracy are  $\pm 0.05$  dB and  $\pm 0.3^\circ$  so that it can accurately measure gain and group delay flatness, which are becoming more important in modern electronics systems.

As a spectrum analyzer, the 4395A operates from 10 Hz to 500 MHz with resolution bandwidths (RBWs) spanning 1 Hz to 1 MHz in a 1-3-10 steps. A fully-synthesized local oscillator allows stable and accurate frequency analysis. Direct A/D conversion (no LOG amplifier is used) results in  $\pm 0.8$  dB level accuracy (@50 MHz,  $-20$  dBm). Noise sidebands fall below  $-110$  dBc/Hz @ 100 kHz offset from carriers, while sensitivity is  $-145$  dBm/Hz at 10 MHz.

### Extremely Fast Spectrum Measurement

The 4395A features Fast Fourier Transform (FFT) digital-signal-processing (DSP) technique for 20 to 100 times faster narrowband spectrum measurement than swept-tuned spectrum analyzers. The stepped FFT is performed for all RBW settings. For example, with 100 Hz RBW and 100 kHz span, the 4395A has a sweep time of 300 ms, while swept-tuned spectrum analyzers take a few tens of seconds. The stepped FFT can greatly improve the efficiency of narrowband spectrum measurement.

### Time-Gated Spectrum Analysis

With Option 1D6, the 4395A offers time-gated spectrum analysis capability to capture and measure repetitive burst signals in video, disk drives, communication equipment, and more. The minimum gate length is  $6\mu$  sec so that even narrow-burst signals can be analyzed.

### Impedance Measurement Function and RF Impedance Test Kit

A full-featured impedance measurement function (useful for quick-check general-purpose impedance applications) can be added to the 4395A by adding Option 010 and the 43961A RF impedance test kit. Covering from 100 kHz to 500 MHz, impedance parameters  $|Z|$ ,  $\theta$ , C, L, Q, D, and more, are directly measured and displayed on the TFT color display. The basic impedance measurement accuracy is 3%. A 7mm connector is mounted on this kit for easy connection to an appropriate impedance test fixture. A wide variety of fixtures can be used with this test kit, including the surface-mount-device (SMD) fixtures used with the E4991A RF impedance/material analyzer. The Option 001 DC source is useful in applying DC voltage to the device up to 40 V.

## 4395A Specifications Summary

### Network Measurement

#### Frequency Characteristics

**Range:** 10 Hz to 500 MHz  
**Resolution:** 1 mHz  
**Accuracy:** < ±5.5 ppm (Option 1D5: < ±0.13 ppm)

#### Output Characteristics

**Power Range:** -50 to +15 dBm  
**Resolution:** 0.1 dB  
**Level Accuracy:** ±1.0 dB @ 0 dBm, 50 MHz

#### Receiver Characteristics

**Frequency Range:** 10 Hz to 500 MHz  
**Noise Level** (referenced to full scale input level, 23 ±5° C):  
 -85 dB (typical) @ 10 Hz ≤ f < 100 Hz, IFBW=2 Hz  
 -85 dB @ 100 Hz ≤ f < 100 kHz, IFBW=10 Hz  
 (-115 + f/100 MHz) dB @ 100 kHz ≤ f, IFBW=10 Hz

**IF Bandwidth (Hz):** 2, 10, 30, 100, 300, 1k, 3k, 10k, 30k

#### Dynamic Accuracy

Input Level (relative to full scale input level -10 dB)	Dynamic Accuracy Frequency ≥ 100 Hz
<b>Magnitude Dynamic Accuracy</b>	
0 dB ≥ input level ≥ -10 dB	±0.4 dB
-10 dB > input level ≥ -60 dB	±0.05 dB
-60 dB > input level ≥ -80 dB	±0.3 dB
-80 dB > input level ≥ -100dB	±3 dB
<b>Phase Dynamic Accuracy</b>	
0 dB ≥ input level ≥ -10 dB	±3°
-10 dB > input level ≥ -60 dB	±0.3°
-60 dB > input level ≥ -80 dB	±1.8°
-80 dB > input level ≥ -100dB	±18°

@ R port input level=full scale input level -10 dB, IFBW=10 Hz, 23 ±5° C

### Spectrum Measurement

#### Frequency Characteristics

**Frequency Range:** 10 Hz to 500 MHz

#### Frequency Reference

**Accuracy:** < ±5.5 ppm (Option 1D5: < ±0.13 ppm)

#### Resolution Bandwidth (RBW)

**Range:** 1 Hz to 1 MHz, 1-3-10 step @ span > 0  
 3k, 5k, 10k, 20k, 40k, 100k, 200k, 400k, 800k, 1.5 M, 3 M, 5 MHz @ span=0

**Selectivity** (60 dB/3 dB): < 3 @ span > 0

#### Noise Sidebands

##### Offset

1 kHz -97 dBc/Hz  
 10 kHz -97 dBc/Hz  
 100 kHz -110 dBc/Hz  
 1 MHz -110 dBc/Hz

#### Displayed Average Noise Level

##### Frequency

1 kHz ≤ f < 100 kHz -120 dBm/Hz  
 100 kHz ≤ f < 10 MHz -133 dBm/Hz  
 10 MHz ≤ f (-145 + f/100 MHz) dBm/Hz

#### Spurious Response

**Second Harmonic Distortion:** -70 dBc @ -16 dB full scale  
**Third-Order Intermodulation Distortion:** -70 dBc @ -16 dB full scale  
**Other Spurious:** -70 dBc @ -16 dB full scale

#### Scale Fidelity

±0.05 dB @ 0 to -30 dB from full scale input level -10 dB

### Impedance Measurement (Option 010)

**Measurement Parameters:** |Z|, θz, |Y|, θy, R, X, G, B, Cp, Cs, Lp, Ls, Rp, Rs, D, Q, |Γ|, θγ, Γx, Γy

**Frequency Range:** 100 kHz to 500 MHz

**Measurement Port:** 7mm connector on the 43961A Test Kit

**Source Level at Measurement Port:** -56 to +9 dBm @ 50 Ω

**Calibration:** OPEN/SHORT/LOAD calibration,

OPEN/SHORT/LOAD compensation on test fixtures, port extension

**Accuracy** (Supplemental Performance Characteristics):

± 3% basic accuracy @ 23 ±5° C, after OPEN/SHORT/LOAD calibration

## General Characteristics

### Full Scale Input Level

Attenuator setting (dB)	Full Scale Input Level	
	Network	Spectrum
0	-10 dBm	-20 dBm
10	0 dBm	-10 dBm
20	+10 dBm	0 dBm
30	+20 dBm	+10 dBm
40	+30 dBm	+20 dBm
50	+30 dBm	+30 dBm

### Option 001 DC Voltage/Current Source

**Voltage Range:** -40 V to +40 V

**Current Range:** -20 mA to -100 mA, 20 mA to 100 mA

### Operating Temperature/Humidity

**Disk Drive Non-Operating Condition:** 0° C to 40° C, 15% to 95% RH

**Disk Drive Operating Condition:** 10° C to 40° C, 15% to 80% RH

**Storage Temperature/Humidity:** -20° C to 60° C, 15% to 95% RH

**Power Requirement:** 100/120/220/240 V ±10%, 47 Hz to 66 Hz, 300 VA max.

**Size:** 235 mm H x 425 mm W x 553 mm D (9.4 in x 17 in x 22.12 in)

**Weight:** 21 kg (46.2 lb) (typical)

## Key Literature

4395A/96B Awareness Brochure, p/n 5965-9374E

4395A Network/Spectrum/Impedance Analyzer, Technical Specifications, p/n 5965-9340E

4395A/4396B Special Option U01 (Education package), p/n 5968-2251E

Dramatic Speed Improvement for Narrow RBW Sweeps by

Audio/Video/IF/RF/Spectrum Analyzers, p/n 5966-4099E

Network, Spectrum, and Impedance Evaluation of Electronic Circuits and Components, p/n 5967-5942E

How to Measure Noise Accurately Using the Combination Analyzers, p/n 5966-2292E

ADSL Copper Loop Measurements, p/n 5968-1196E

## Ordering Information

**4395A** Network/Spectrum/Impedance Analyzer

**Opt 001** Add DC Source

**Opt 010** Add Impedance Measurement Function (Requires 43961A)

**Opt 1A2** Delete Keyboard

**Opt 1D5** Add High Stability Frequency Reference

**Opt 1D6** Add Time-Gated Spectrum Analysis

**Opt 1D7** 50 Ω to 75 Ω Minimum Loss Pad

**87511A** 50 Ω S-Parameter Test Sets

**Opt 001** N Type Port

**87511B** 75 Ω S-Parameter Test Sets

**87512A** 50 Ω Transmission/Reflection Test Kits

**87512B** 75 Ω Transmission/Reflection Test Kits

**43961A** RF Impedance Test Kit (add test fixture listed below)

**16191A** Side Electrode SMD Test Fixture

**16192A** Parallel Electrode SMD Test Fixture

**16196A/B/C** Parallel Electrode SMD Test Fixture

**16197A** Bottom Electrode SMD Test Fixture

**16092A** Spring Clip Test Fixture

4396B

- Full-vector network and spectrum measurement and analysis
- Wide dynamic range network measurement with fast sweep speeds
- $\pm 0.05$  dB/ $\pm 0.3^\circ$  C dynamic magnitude/phase accuracy
- Extremely fast narrowband spectrum measurement
- Impedance analysis option and test kit available
- $\pm 1.0$  dB level accuracy for spectrum analysis
- $-150$  dBm/Hz sensitivity for spectrum analysis
- Built-in IBASIC for easy test automation
- Time-gated spectrum analysis option
- Color TFT display and built-in disk drive/RAM disk

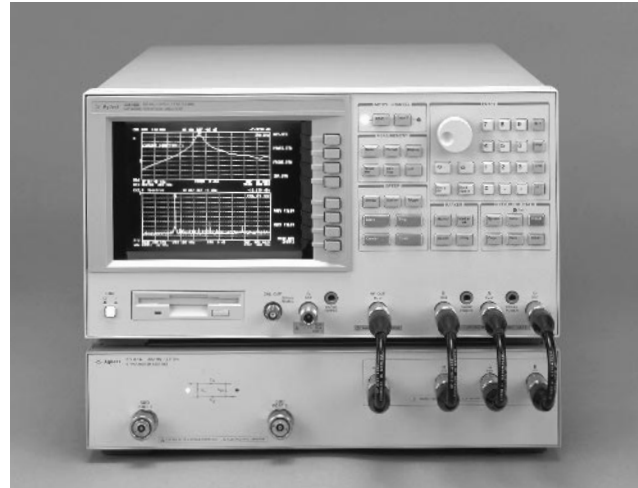

4396B with 85046A

### 4396B RF Network/Spectrum Impedance Analyzer

5

The 4396B provides excellent RF vector network, spectrum, and optional impedance measurements for lab and production applications. Gain, phase, group delay, distortion, spurious, CN, and noise measurements often required for evaluating components and circuits can be measured using one instrument. When combined with a test set, the 4396B provides reflection measurements, such as return loss, and SWR, and S parameters. As a vector network analyzer, the 4396B operates from 100 kHz to 1.8 GHz with 1 mHz resolution and its integrated synthesized source provides  $-60$  to  $+20$  dBm of output power with 0.1 dB resolution. The dynamic magnitude and phase accuracy are  $\pm 0.05$  dB and  $\pm 0.3^\circ$  so that it can accurately measure gain and group delay flatness, which are becoming more important in modern electronics systems.

As a spectrum analyzer, the 4396B operates from 2 Hz to 1.8 GHz with resolution bandwidths (RBWs) spanning 1 Hz to 3 MHz in a 1-3-10 sequence. A fully-synthesized local oscillator allows stable and accurate frequency analysis. Direct A/D conversion (no LOG amplifier is used) results in  $\pm 1.0$  dB overall level accuracy. Noise sidebands fall below  $-105$  dBc/Hz offset 10 kHz from carriers below 1 GHz, while sensitivity is  $-150$  dBm/Hz at 10 MHz and  $-147$  dBm/Hz at 1 GHz. In addition, with two independent display channels available, you can simultaneously view network and spectrum (or transmission and reflection) characteristics of the device under test in split-screen format. For example, an amplifier's frequency response (network measurement) and distortion (spectrum measurement) can be shown at the same time.

### Extremely Fast Spectrum Measurement

The 4396B features a stepped Fast Fourier Transform (FFT) digital-signal-processing (DSP) technique for 20 to 100 times faster narrowband spectrum measurement than swept-tuned spectrum analyzers. The stepped FFT is performed when the resolution bandwidth (RBW) is set at 3 kHz or below. For example, with a 30 Hz RBW and 10 kHz span, the 4396B has a sweep time of 400 ms, while swept-tuned spectrum analyzers take a few tens of seconds. The stepped FFT can greatly improve the speeds of narrowband spectrum measurement such as frequency tuning of a VCO or CN measurements.

### Time-Gated Spectrum Analysis

With Option 1D6, the 4396B offers time-gated spectrum analysis capability to capture and measure repetitive burst signals in video, disk drives, communication equipment, and more. The minimum gate length is 2  $\mu$  sec so that even narrow-burst signals can be analyzed.

### Impedance Measurement Function and RF Impedance Test Kit

A full-featured impedance measurement function (useful for quick-check general-purpose impedance applications) can be added to the 4396B by adding Option 010 and the 43961A RF impedance test kit. Covering from 100 kHz to 1.8 GHz, impedance parameters  $|Z|$ ,  $\theta$ , C, L, Q, D, and more, are directly measured and displayed. The basic impedance accuracy (typical value) is 3%. The 43961A RF impedance test kit is designed for the 4396B and is required to utilize the features of Option 010. A 7mm connector is mounted on this kit for easy connection to an appropriate impedance test figure.

A wide variety of Agilent test fixtures can be used with the test kit, including the surface-mount-device (SMD) fixtures. For higher frequency, more accurate and complete impedance analysis capabilities over the wider impedance ranges, the E4991A RF impedance/material analyzer is recommended. See pages 487 and 488.



### 4396B Specifications Summary

#### Network Measurement

##### Frequency Characteristics

**Range:** 100 kHz to 1.8 GHz  
**Resolution:** 1 mHz  
**Accuracy:**  $\leq \pm 5.5$  ppm (Option 1D5:  $\leq \pm 0.13$  ppm)

##### Output Characteristics

**Power Range:** -60 to +20 dBm  
**Resolution:** 0.1 dB  
**Level Accuracy:**  $\leq \pm 0.5$  dB

##### Receiver Characteristics

**Frequency Range:** 100 kHz to 1.8 GHz  
**Noise Level** (10 Hz IFBW,  $\geq 10$  MHz,  $f$ =frequency in GHz):  
 $< (-125 + 3 \times f)$  dBm (A, B inputs);  
 $< (-100 + 3 \times f)$  dBm (R input)  
**Full Scale Input Level:** -5 dBm (A, B), +20 dBm (R)  
**IF Bandwidth** (Hz): 10, 30, 100, 300, 1k, 3k, 10k, 40k

##### Dynamic Accuracy

###### Input level (relative to full scale input level)

###### Magnitude Dynamic Accuracy

0 dB	$\leq \pm 0.3$ dB
-10 to -70 dB	$\leq \pm 0.05$ dB
-80 dB	$\leq \pm 0.1$ dB
-90 dB	$\leq \pm 0.3$ dB
-100 dB	$\leq \pm 1.0$ dB
-110 dB	$\leq \pm 0.8$ dB typical
-120 dB	$\leq \pm 2.5$ dB typical

###### Phase Dynamic Accuracy

0 dB	$\leq \pm 3^\circ$
-10 dB	$\leq \pm 0.6^\circ$
-20 to -70 dB	$\leq \pm 0.3^\circ$
-80 dB	$\leq \pm 0.7^\circ$
-90 dB	$\leq \pm 2^\circ$
-100 dB	$\leq \pm 7^\circ$
-110 dB	$\leq \pm 8^\circ$ typical
-120 dB	$\leq \pm 25^\circ$ typical

@ 23  $\pm$  5° C, IFBW 10 Hz, R input = -35 dBm

##### Measurement Throughput Summary (IFBW 40 kHz, ms)

Measurement (with THRU Cal)	Number of points			
	51	201	401	801
(1) Magnitude	62	138	239	443
(2) Magnitude and phase	84	227	417	798

#### Spectrum Measurement

##### Frequency Characteristics

**Frequency Range:** 2 Hz to 1.8 GHz

##### Frequency Reference

**Accuracy:**  $\leq \pm 5.5$  ppm (Option 1D5:  $\leq \pm 0.13$  ppm)

##### Resolution Bandwidth (RBW)

**Range:** 1 Hz to 3 MHz, 1-3-10 step  
**Selectivity** (60 dB/3 dB): RBW  $\geq 10$  kHz:  $< 10$ ; RBW  $\leq 3$  kHz:  $< 3$

##### Noise Sidebands

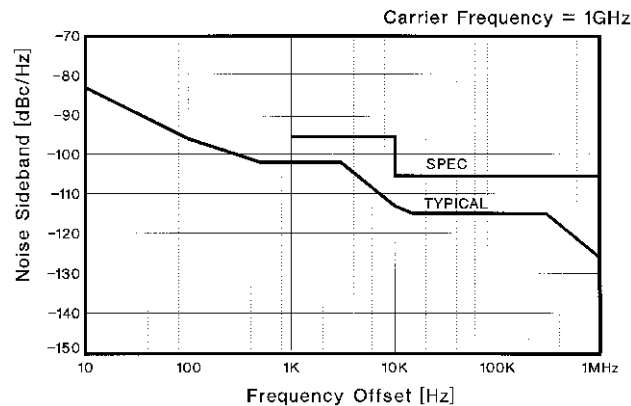

Noise sidebands normalized to 1 Hz RBW versus offset from carrier (typical)

##### Displayed Average Noise Level

(@ frequency  $\geq 10$  MHz, ref. level  $\leq -40$  dBm, att.=0 dBm):  
 $< (-150 + 3f)$  (GHz) dBm/Hz

##### Spurious Response

**Second Harmonic Distortion** (@  $\geq 10$  MHz, -35 dBm mixer input):  
 $< -70$  dBc

**Third-Order Intermodulation Distortion** (@  $\geq 10$  MHz, -30 dBm, separation  $> 20$  kHz):  $< -75$  dBc

**Other Spurious** (@ -30 dBm mixer input, offset  $\geq 1$  kHz):  $< -70$  dBc

**Scale Fidelity:**  $\pm 0.05$  dB @ 0 to -30 dB from ref. level

##### Impedance Measurement (Option 010)

**Measurement Parameters:**  $|Z|, \theta_z, |Y|, \theta_y, R, X, G, B, C_p, C_s, L_p, L_s, R_p, R_s, D, Q, |\Gamma|, \theta_\gamma, \Gamma_x, \Gamma_y$

**Frequency Range:** 100 kHz to 1.8 GHz

**Measurement Port:** 7mm connector on the 43961A Test Kit

**Source Level at RF out:** -60 to +20 dBm (6 dB lower at 43961A port)

**DC Bias:**  $\pm 40$  V (20 mA maximum). A 2 k $\Omega$   $\pm 5\%$  internal resistor is used for dc bias current limitation. An external dc bias source is required.

**Connector:** BNC (f) on 43961A.

**Calibration:** OPEN(0 S)/SHORT (0  $\Omega$ )/LOAD(50  $\Omega$ ) calibration, OPEN/SHORT/LOAD compensation on test fixtures, port extension compensation

**Accuracy** (Supplemental Performance Characteristics): 3% basic accuracy at 23° C  $\pm 5^\circ$  C, after OPEN/SHORT/LOAD calibration

#### General Characteristics

**Operating Temperature/Humidity:** 0° C to 40° C, 15% < RH < 95%

**Storage Temperature:** -20° C to 60° C

**Power Requirement:** 90 V to 132 V, 198 V to 264 V, 47 Hz to 63 Hz, 300 VA max.

**Weight:** 21.5 kg (47.3 lb) typical

**Size:** 235 mm H x 425 mm W x 553 mm D (9.4 in x 17 in x 22.12 in)

#### Key Literature

4395A/96B Awareness Brochure, p/n 5965-9374E

4396B 1.8 GHz Network/Spectrum Analyzer Technical Data, p/n 5965-6311E

Combining Network and Spectrum Analyses and IBASIC to improve device characterization and test time, p/n 5965-7656E

Configuring the 4396B for O/E Testing, p/n 5965-7657E

Using the 4396B for Digital VTR Testing, p/n 5965-7658E

How to Characterize CATV Amplifiers Effectively, p/n 5965-9434E

Dramatic Speed Improvement for Narrow RBW Sweeps by

Audio/Video/IF/RF/Spectrum Analyzers, p/n 5966-4099E

Network, Spectrum, and Impedance Evaluation of Electronic Circuits and Components, p/n 5967-5942E

How to Measure Noise Accurately Using the Combination Analyzers, p/n 5966-2292E

4395A/4396B Special Option U01 (Education package), p/n 5968-2251E

#### Ordering Information

**4396B** RF Network/Spectrum/Impedance Analyzer

**Opt 1A2** Delete keyboard

**Opt 1D5** High-Stability Frequency Reference

**Opt 1D6** Time-Gated Spectrum Analysis

**Opt 1D7** 50  $\Omega$  to 75  $\Omega$  Spectrum Input Impedance Conversion

**Opt 010** Impedance Measurement Function (Requires 43961A)

**85046A** 50  $\Omega$  S-Parameter Test Sets

**85046B** 75  $\Omega$  S-Parameter Test Sets

**87512A** 50  $\Omega$  Transmission/Reflection Test Kits

**87512B** 75  $\Omega$  Transmission/Reflection Test Kits

**43961A** RF Impedance Test Kit (add test fixtures listed below)

**16191A** Side Electrode SMD fixture (dc to 2 GHz)

**16192A** Parallel Electrode SMD fixture (dc to 2 GHz)

**16196A/B/C** Parallel Electrode SMD Test Fixture

**16197A** Bottom Electrode SMD Test Fixture

**16092A** Spring-Clip Fixture (dc to 500 MHz)

43961A  
87511A  
87511B  
87512A  
87512B  
41800A



43961A

### 43961A RF Impedance Test Kit

The 43961A RF Impedance Test Kit provides the capability to measure impedance parameters of 1-port devices with the 4395A Option 010 (100 kHz to 500 MHz) or the 4396B Option 010 (100 kHz to 1.8 GHz). The test port of the 43961A is a 7-mm connector and can be used with the 16191A, 16192A, or 16193A test fixture. The 43961A includes open/short/load calibration standards, and the test fixtures such as 16192A are optional.

**Frequency Range:** 100 kHz to 1.8 GHz (100 kHz to 500 MHz with 4395A)  
**Measurement Parameters:**  $|Z|$ ,  $|Y|$ ,  $\theta$ , R, X, G, B, Cp, Cs, Lp, Ls, Rp, Rs, D, Q,  $|\Gamma|$



87511A

### 87511A/B S-Parameter Test Sets

The 87511A/B S-Parameter Test Sets provide the capability to measure S-parameters of 2-port devices from 100 kHz to 500 MHz with a network analyzer. The test ports of the 87511A are 50  $\Omega$  precision 7-mm connectors (Option 001: type N(f)), and the test ports of the 87511B are 75  $\Omega$  type N(f) connectors. Calibration kits are not included.

**Frequency Range:** 100 kHz to 500 MHz  
**Test Port Impedance:** 87511A, 50  $\Omega$ ; 87511B, 75  $\Omega$

	87511A	87511B
<b>Directivity</b>		
100 kHz to 300 kHz	30 dB	30 dB
300 kHz to 200 MHz	40 dB	33 dB
200 MHz to 500 MHz	35 dB	33 dB
<b>Nominal Insertion Loss</b>		
RF IN to port 1, 2	13 dB	19 dB
RF IN to R, A, B	19 dB	31 dB

**Size:** 90 mm H x 432 mm W x 495 mm D (3.6 in x 17.28 in x 19.8 in)  
**Weight:** 5.7 kg (12.54 lb) (typical)



87512A

### 87512A/B Transmission/Reflection Test Kits

87512A/B Transmission/Reflection Test Kits provide the capability to measure the reflection and transmission characteristics of 50  $\Omega$  or 75  $\Omega$  devices up to 2 GHz with an Agilent network analyzer. The test port of the 87512A is a 50  $\Omega$  type N(f) connector, and the test port of the 87512B is a 75  $\Omega$  type N(f) connector. The 87512A/B include precision short/load termination for calibration.

**Frequency Range:** DC to 2 GHz  
**Test Port Impedance:** 87512A, 50  $\Omega$ ; 87512B, 75  $\Omega$   
**Equivalent Directivity:** 40 dB (typical)  
**Insertion Loss:** 10 dB  $\pm$  1 dB



41800A

### 41800A Active Probe

The 41800A Active Probe provides high input impedance from 5 Hz to 500 MHz. The 41800A is a valuable tool when used with a network and spectrum analyzer for circuit signal analysis.

#### Specifications

**Bandwidth:** 5 Hz to 500 MHz  
**Output Connector:** 50  $\Omega$  type N male  
**Input R,C (typical):** 100 k  $\Omega$ , 3 pF (probe alone); 1 M $\Omega$ , 1 pF (with 10:1, 100:1 divider)  
**Frequency Response relative to 50 MHz:**  $\pm$ 1 dB @ 50 Hz to 200 MHz  
**Average Noise Level:** 10 nV/ $\sqrt{\text{Hz}}$  @  $\geq$ 300 kHz  
**Second Harmonic Distortion:**  $<$ -50 dBc @ 20 dBm (250 MHz) input (typical)  
**Third-Order Intermodulation Distortion:**  $<$ -70 dBc @ -26 dBm two signal input (typical)  
**1 dB Gain Compression:**  $>$ +3 dBm input @ 500 MHz



### Why Network Analysis?

Characterizing the behavior of linear electrical networks that will be stimulated by arbitrary signals and interfaced with a variety of other networks is a fundamental problem in both synthesis and test processes. For example, the engineer designing a multi-component network must predict with some certainty, from knowledge of the individual components, the final network performance. Similarly, a production manager must know allowable tolerances on the products manufactured and whether the final products meet the specified tolerances. Network analysis offers a solution to these problems through complete description of linear network behavior in the frequency domain. Additionally, some network analyzers offer the capability to transform measurement data, taken in the frequency domain, to the time domain, providing further insight into the behavior of linear networks.

Network analysis accomplishes the description of both active and passive networks by creating a data model of such component parameters as impedances and transfer functions. However, these parameters not only vary as a function of frequency but are also complex variables in that they have both magnitude and phase (see Figure 1). Swept network analyzers now measure magnitude and phase (the total complex quantity) as a function of frequency with less difficulty than conventional CW measurements. Impedance and transfer functions then can be displayed conveniently on an internal display, or on peripherals such as a printer and/or a plotter.

Thus, network analysis satisfies the engineering need to characterize the behavior of linear networks quickly, accurately, and completely over broad frequency ranges. Agilent Technologies manufactures a full line

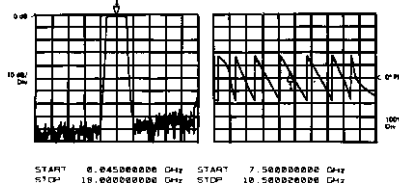

Figure 1: 45 MHz to 18 GHz measurement of magnitude and phase in a single sweep.

of scalar network analyzers (magnitude only) and vector network analyzers (both magnitude and phase).

### What is Network Analysis?

Network analysis is the process of creating a data model of the transfer and/or impedance characteristics of a linear network through stimulus-response testing over the frequency range of interest. All network analyzers in the Agilent product line operate according to this definition.

At frequencies above 1 MHz, lumped elements actually become “circuits” consisting of the basic elements plus parasitics like stray capacitance, lead inductance, and unknown absorptive losses. Since parasitics depend on the individual device and its construction, they are almost impossible to predict. Above 1 GHz component geometries are comparable to a signal wavelength, intensifying the variance in circuit behavior due to device construction.

Network analysis has classically been limited to the definition of linear networks. Since linearity constrains networks stimulated by a sine wave to produce a sine-wave output, sine-wave testing is an ideal method for characterizing magnitude and phase response as a function of frequency. While modern net-

work analyzers use sine-wave power sweeps to characterize certain parameters of nonlinear behavior, such as gain compression and AM-to-PM conversion, this discussion will be limited to linear characterization of devices. For a more complete discussion of nonlinear measurements, refer to the sections on spectrum analyzers, wave analyzers (signal analyzers) and vector modulation products in this catalog.

### Network Analyzers

Agilent network analyzers are instruments that measure transfer and/or impedance functions of linear networks through sine-wave testing (see Figure 2). A network analyzer system accomplishes these measurements

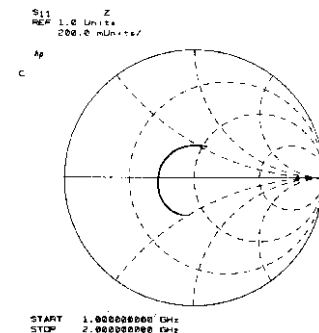

Figure 2: Input impedance of microcircuit amplifier is read directly with Smith Chart overlay for polar display.

by configuring its various components around the device-under-test. The first requirement of the measurement system is a sine-wave signal source to stimulate the device-under-test. Since transfer and impedance functions are ratios of various voltages and currents, a means of separating the appropriate signals from the measurement ports of the device-under-test is required. Finally, the network analyzer itself must detect the separated signals, form the desired signal ratios and display the results.

### Signal Sources and Signal Separation

In the general case, any sine-wave source meeting the network analyzer’s specifications can be used to stimulate the device-under-test. If the analyzer is capable of swept measurements, great economies in time can be achieved by stimulating the device-under-test with a sweep oscillator or synthesized sweeper. Many Agilent network analyzers contain internal, synthesized sources with excellent frequency resolution. Swept measurements allow quick and easy characterization of devices over broad frequency ranges.

At high frequencies the problem of signal separation usually involves traveling waves on transmission lines and becomes correspondingly more difficult. Agilent network analyzers employ both internal and external test sets applicable for separating the appropriate traveling waves in a variety of high-frequency measurements.



### Broadband and Narrowband Detection

After the desired signals have been obtained from the test set, they must be detected by the network analyzer; Agilent network analyzers can use one of two detection methods. Broadband detection accepts the full-frequency spectrum of the input signal, while narrowband detection involves tuned receivers that convert CW or swept-RF signals to a constant-IF signal. There are certain advantages to each detection scheme.

Scalar analyzers usually employ broadband detection techniques. Broadband detection reduces instrument cost by eliminating the IF section required by narrowband analyzers but sacrifices noise and harmonic rejection. However, noise is not a factor in many applications. Finally, broadband systems can make measurements where the input and output signals are not of the same frequency, as in the measurement of the insertion loss of mixers and frequency doublers.

Vector network analyzers normally employ narrowband detection techniques. Narrowband detection makes a more sensitive low noise detection of the constant IF possible. This allows increased accuracy and dynamic range for frequency-selective measurements (as compared to broadband systems).

Vector network analyzers can vary with their employment of broadband, narrowband, or both types of detection. When both types of detection are available, the user selects the detection method, which allows optimization of the device measurements.

### Signal Processing and Display

Once the RF has been detected, the network analyzer must process the detected signals and display the measured quantities (see Figure 3). All Agilent network analyzers are multi-channel receivers utilizing a reference channel and at least one test channel; absolute signal levels in the channels, relative signal level (ratios) between the channels, or relative phase difference between channels can be measured, depending on the analyzer.

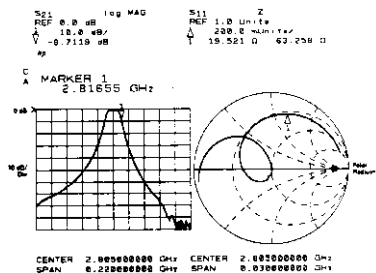

Figure 3: Simultaneous measurement of transmission response and passband reflection coefficient.

Relative ratio measurements are usually made in dB, which is the log ratio of an unknown signal (Test Channel) with a chosen reference signal (Reference Channel). This allows the full dynamic range of the instrumentation to be used in measuring variations of both high- and low-level circuit responses. For example, 0 dB implies the two signal levels have a ratio of unity, while  $\pm 20$  dB implies a 10:1 voltage ratio between two signals.

All network analyzer phase measurements are relative measurements with the reference channel signal considered to have zero phase. The analyzer then measures the phase difference of the test channel with respect to the reference channel.

Phase information complements amplitude data in the measurement of device parameters. Phase is more sensitive to network behavior and it is a required component of complex impedance and transfer functions.

Phase data is also required to measure delay distortion or group delay of networks. Delay distortion occurs when different frequency components of a complex waveform experience nonlinear phase shifts as they are transmitted through a network. Group delay (see Figure 4) is a measure of this distortion and is defined as:

$$T_{gd} = \frac{-d\theta}{d\omega}$$

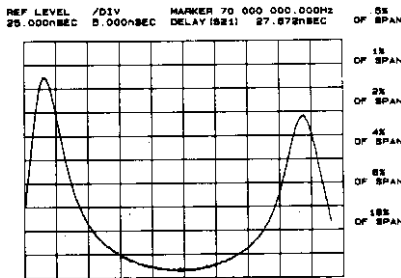

Figure 4: Direct measurement of group delay with digital readout at marker.

An alternative method for measuring phase distortion is deviation from linear phase or differential phase. Deviations from linear phase can be measured by introducing enough electrical length in the network analyzer's reference channel to linearize a device's phase shift. This is usually accomplished by using the electrical-delay feature of the network analyzer, which cancels the average electrical length of a device mathematically.

Scattering parameters, or S-parameters, were developed to characterize linear networks at high frequencies. S-parameters define the ratios of reflected and transmitted traveling waves measured at the network ports. A two-port device is modeled with S-parameters (see Figure 5).  $S_{11}$  is the complex reflection coefficient at port 1, and is the

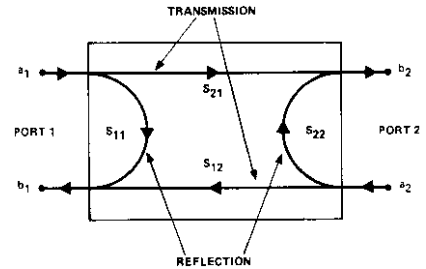

Figure 5: S-parameter model for a two-port linear network.

ratio of  $b_1/a_1$ , if  $a_2 = 0$  (port 2 terminated in its characteristic impedance).  $S_{21}$  is the complex transmission coefficient from port 1 to port 2,  $b_2/a_1$ , if  $a_2 = 0$ . The "a" and "b" signals represent the amplitude and phase of the incident and emerging or reflected traveling waves. By reversing the ports and terminating port 1 in its characteristic impedance,  $S_{22}$  and  $S_{12}$  can be similarly defined.

### Additional Capabilities

Precision design work and manufacturing tolerances demand highly accurate measurements, but most errors in network measurements are complex quantities that vary as a function of frequency. By characterizing and virtually removing these systematic errors, measurement accuracies are improved by several orders of magnitude. Agilent network analyzers contain built-in, high-speed computational hardware that can perform the complex mathematics required for sophisticated error correction.

Computer-controlled network analyzers can be programmed to set up and make many measurements automatically. The measurement process is further accelerated by the computer's ability to store, transform, summarize, and output data in a variety of formats to a number of peripherals. These capabilities make the computer-controlled network analyzer ideal for both computer-aided design or automatic production testing. Several products have built-in automation features, including sequencing and GP Instrument BASIC.



### Network Analyzer Selection Guide

Model	Frequency range	Key Features
<b>E8356A</b> <b>E8357A</b> <b>E8358A</b> PNA Series (page 274)	300 kHz to 3 GHz 300 kHz to 6 GHz 300 kHz to 9 GHz	35µsec/pt. sweep speed 128 – 143 dB dynamic range Time-domain mode/gating TRL calibration Windows 2000 OS
<b>E5100A/B</b> (page 281)	10 kHz to 180 MHz (or 300 MHz)	Swept-frequency-list mode Built-in IBASIC and GPIB Waveform analysis commands for faster manufacturing test
<b>8712ET/ES</b> <b>8714ET/ES</b> (page 283)	300 kHz to 1.3 GHz 300 kHz to 3 GHz	Self-calibrating multiport test sets SRL/fault location option Built-in IBASIC Narrowband/broadband detection LAN
<b>8753ET/ES</b> (page 287)	30 kHz to 3 GHz (or 6 GHz)	Swept-frequency-list mode Harmonic measurements Time-domain mode/gating 4-parameter display
<b>8719ET/ES</b> <b>8720ET/ES</b> <b>8722ET/ES</b> (page 291)	50 MHz to 13.5 GHz 50 MHz to 20 GHz 50 MHz to 40 GHz	Swept-frequency-list mode High-power measurement Time-domain mode/gating TRL calibration 4-parameter display
<b>8510 Series</b> (page 295)	45 MHz to 110 GHz	Coaxial measurements 110 GHz in one sweep Banded waveguide measurements Pulsed-RF measurements Time-domain mode/gating TRL (standard)
<b>8757D/E</b> (page 276)	10 MHz to 110 GHz	Scalar, diode detection Power meter calibration Easy mixer measurements Waveguide measurements

### Network/Spectrum/Impedance Analyzers

Model	Frequency range	Key Features
<b>4395A</b> (page 267)	10 Hz to 500 MHz (SA) 10 Hz to 500 MHz (NA) 100 kHz to 500 MHz (ZA)	Full vector-network and spectrum measurement and analysis Built-in IBASIC
<b>4396B</b> (page 268)	100 kHz to 1.8 GHz (NA) 2 Hz to 1.8 GHz (SA) 100 kHz to 1.8 GHz (ZA)	Wide dynamic range network measurements with fast sweep speeds

### Vector Voltmeter

Model	Frequency range	Key Features
<b>8508A</b> (page 294)	100 kHz to 1 GHz 300 kHz to 2 GHz	No source GPIB programmable High-impedance probe inputs

For a complete network analyzer guide, please ask for p/n 5968-5260E, or visit our web site: [www.agilent.com/find/na](http://www.agilent.com/find/na)

E8356A  
E8357A  
E8358A

- 35  $\mu$ s/point measurement speed
- 128 dB–143 dB dynamic range
- 0.005 dB rms trace noise
- COM/DCOM interface-enabled
- Optional time-domain measurements
- TRL/LRM calibration
- Windows 2000 OS

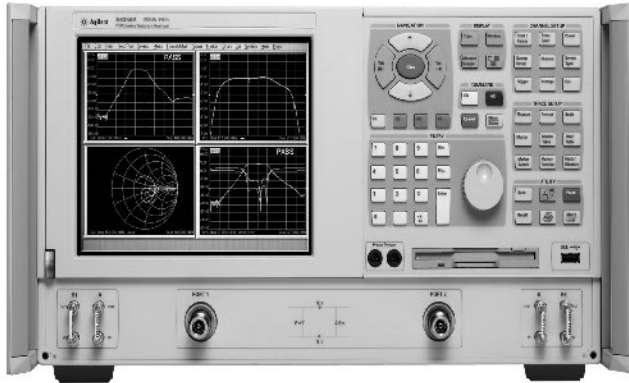

The Agilent PNA series offers the highest performance among vector network analyzers. The series offers exceptional speed, dynamic range, accuracy, and configurability that can reduce time to market in R&D or maximize throughput in manufacturing. These analyzers enable engineers who design and test high-performance RF components to quickly and easily make measurements and then analyze and communicate the results.

### PNA Series Features

#### High Performance

Agilent's PNA series of vector network analyzers offer unparalleled measurement capabilities to better characterize your high-performance components. With their combination of 9 GHz frequency coverage, fast sweep speeds, exceptional dynamic range, low trace noise, four measurement receivers, and direct receiver access, you will have all the power and flexibility you need for almost any RF application.

The PNA series comes in 3, 6, or 9 GHz models (E8356A, E8357A, E8358A, respectively). Using the widest bandwidth and 1601 points, you get measurements at 35  $\mu$ s/point. This speed does not come at the expense of trace noise. The 35 kHz IF bandwidth boasts an impressively low trace noise of 0.004 dB RMS. The result is very accurate measurements of low-loss devices. With direct access to measurement receivers, you can measure up to 143 dB of dynamic range. This increased measurement range enables clear, precise measurements of base station filters or LNA receiver/filter combinations.

The PNA series provides additional accuracy through TRL/TRM calibration. The series uses four mixer-based receivers so you can utilize true TRL/TRM calibration for accurate in-fixture and on-wafer measurements.

The time-domain option (Option 010) allows you to locate and resolve discontinuities in devices, fixtures, or cables. Once located, unwanted responses can be removed using the gating function. Option 010 also furnishes a very simple and deterministic technique to tune cavity-resonator filters.

Option 015 provides a configurable test set for maximum flexibility. Front panel access to the RF signal path allows for customization within the test set. You can configure the signal path for up to 143 dB of dynamic range at the test port with full 2-port error correction. In order to achieve this dynamic range, simply reverse the coupler for increased dynamic range in one direction and use segment sweep mode.

#### Advanced Connectivity

The PNA series achieves new levels of connectivity. There are many methods of communication to and from the instrument, using a variety of built-in I/O interfaces. Windows 2000 lets you take advantage of many features you take for granted on your personal computer, helping you attain a new level of integration for your device-measurement process.

For local storage, use the analyzer's internal hard disk drive or connect a compatible CD read/write drive. In addition, using drive mapping and the LAN interface, you can save data directly to remote PCs or file servers. This arrangement makes it very easy to develop statistical-process-controlled manufacturing environments.

The PNA series allows a number of ways to connect and control other test equipment such as power meters or signal sources. You can choose to connect them via the available USB, GPIB, LAN, serial, or parallel interfaces. When utilizing any one of your Windows-supported automation tools, you can control the test equipment directly from the analyzer.

The LAN interface also makes it easy to perform remote troubleshooting. You can review measurement results and control the analyzer from anywhere on the network, whether you are on another floor, in another building, or even at a different site. Additionally, as they become available, you can download firmware and help-file updates from our web site: [www.agilent.com/find/pna](http://www.agilent.com/find/pna)

#### Automation

For manufacturing environments, test automation is essential for high throughput. For R&D, automated tests can save considerable time that might be spent on repetitive and tedious measurements. The PNA series lets you automate your test processes using several powerful automation approaches. You can create programs using familiar SCPI commands via the GPIB or LAN interfaces, or use COM commands over LAN for fast analyzer access. The analyzer's firmware interfaces with many programmable objects, or automation "entry points," that respond quickly and directly to COM statements. COM programming makes it easier for you to reuse your test code on multiple computer software and hardware platforms, and makes the actual source code much easier to understand and debug. COM can also give you a significant speed advantage. In some instances, COM-based programs can execute the same instrument settings and transfer data about four times faster than using SCPI. Moreover, programs can be executed internally on the network analyzer or externally on your PC.

#### Throughput

Decreasing test time is often critical for success in manufacturing environments. The PNA series has many attributes that help you accomplish your throughput goals. The outstanding performance of the analyzers starts with exceptionally fast sweeps that do not sacrifice performance. For instance, measurements that require 120 dB (at 401 points, 300 Hz IF bandwidth) of instrument dynamic range, the PNA series sweep speed is only 1.2 seconds.

If you set up your device measurement with a segmented sweep, the analyzer will only measure the device response at the frequency segments that you define. Not only do you control the start and stop frequencies of individual segments, but also the number of points, IF bandwidth, and source power level. This means you can skip data where you do not need it, and have high frequency resolution only where you do need it, such as in the passband of your filters.

Another feature that speeds production testing is pass/fail testing using limit lines. Let the network analyzer quickly determine if the device meets the measurement limits you have defined. A PASS/FAIL indicator on the screen means operators do not have to interpret results.

For devices that once required two to four instrument setups for complete characterization, the PNA series' ability to have up to four measurement channels, each with its own stimulus and response parameters, can also improve your test throughput. When using Agilent's electronic calibration (ECaL) modules, you can dramatically reduce the time it takes to perform calibrations. Simply connect the module to your test ports and let the analyzer control and measure all the standards necessary for full two-port calibrations. These modules are driven directly from the analyzer via a USB connection and controlled via firmware.

Agilent-qualified Channel Partners provide measurement hardware and software solutions that combine with Agilent's network analyzer products to offer a complete solution for your testing needs. For additional information, please refer to page 79.

### Options for the PNA Series

To add options to a PNA series network analyzers after initial purchase, order the analyzer's model number followed by a "U," with one of the following upgrade options that are available for the E8356A, E8357A, and E8358A:

#### Option 010 Time-Domain

With Option 010, you can view reflection or transmission responses in the time domain. Use time domain to locate and quantify individual faults or mismatches in your device, fixture, or cable. Additionally, the time domain capability provides a simple, deterministic method for tuning cavity-resonator bandpass filters.

#### Option 015 Configurable Test Set

With the configurable test set option, front panel access loops are provided to the signal path between the source output and coupler input. Step attenuators are added between the couplers and mixers. You can configure the signal path for up to 143 dB of dynamic range at the test port with full 2-port error correction. In order to achieve this dynamic range, simply reverse the coupler for increased dynamic range in one direction and use segment sweep mode.

#### Option 099 Firmware

Provides the latest revision of firmware for the E8356A, E8357A, or E8358A on a CD-ROM. A USB CD drive (Option AM8) or an external computer connection via LAN is required. The latest firmware is also available free for download from our web site: [www.agilent.com/find/firmware](http://www.agilent.com/find/firmware)

#### Option AM8 Add CD R/W Drive

Adds an external read/write CD drive with a USB cable.

#### Option B30 Add USB Hub

Adds a 4-port USB hub for connecting additional USB peripherals.

### Transit Case

Agilent offers a complete line of sturdy transit cases in valise and tote-style style. The cases protect your instrument from shock, vibration, moisture, impact, and contamination, providing a secure enclosure for shipping. Model 9211-2651 (standard) or model 9211-7522 (tote) fit the PNA series network analyzers.

### Key Literature

PNA Series Brochure, p/n 5968-8472E  
 PNA Series Technical Specifications, p/n 5980-1236E  
 PNA Series Configuration Guide, p/n 5980-1235E

For more information, visit our web site:  
<http://www.agilent.com/find/pna>

### Ordering Information

Note: A complete system consists of a network analyzer, calibration kit, and cables. Calibration kits and cables can be found in the Accessories section beginning on pg. 299.

**E8356A** Network Analyzer, 300 kHz–3 GHz  
**E8357A** Network Analyzer, 300 kHz–6 GHz  
**E8358A** Network Analyzer, 300 kHz–9 GHz

The following options apply to all three network analyzers:

- Opt 010** Time Domain
- Opt 015** Configurable Test Set
- Opt AM8** Add CD R/W Drive
- Opt B30** Add USB Hub
- Opt 1CM** Adds rack mount kit for instrument without handles
- Opt 1CP** Adds rack mount kit for instrument with handles

### Upgrades

To add options to a PNA series network analyzers after initial purchase, order the analyzer's model number followed by a "U," with one of the following upgrade options that are available for the E8356A, E8357A, and E8358A:

- Opt 010** Time Domain
- Opt 015** Configurable Test Set
- Opt 099** Firmware Upgrade
- Opt AM8** Add CD R/W Drive
- Opt 1CL** Add USB Keyboard
- Opt B30** Add USB Hub

### Transit Cases

**9211-2651** Standard Transit Case  
**9211-7522** Tote-Style Transit Case

E8356A  
 E8357A  
 E8358A

## Specifications Summary

	E8356A		E8357A		E8358A	
<b>Impedance</b>	50 ohms		50 ohms		50 ohms	
<b>Test Port Connector</b>	Type-N (female)		Type-N (female)		Type-N (female)	
<b>Frequency Range</b>	300 kHz to 3 GHz		300 kHz to 6 GHz		300 kHz to 9 GHz	
<b>Frequency Resolution</b>	1 Hz		1 Hz		1 Hz	
<b>Trace Noise</b>	Magnitude	Phase	Magnitude	Phase	Magnitude	Phase
1 kHz IF BW	<0.002 dB rms	< 0.010° rms	<0.002 dB rms	< 0.010° rms	<0.002 dB rms	< 0.010° rms
10 kHz IF BW	<0.005 dB rms	< 0.035° rms	<0.005 dB rms	< 0.035° rms	<0.005 dB rms	< 0.035° rms
<b>Source Power Range</b>	300 kHz to 6 GHz		300 kHz to 6 GHz		300 kHz to 9 GHz	
	-85 to +10 dBm		-85 to +10 dBm		-85 to +10 dBm	
	6 GHz to 9 GHz		6 GHz to 9 GHz		-85 to +5 dBm	
<b>Power Resolution</b>	0.05 dB		0.05 dB		0.05 dB	
<b>Power Level Linearity</b>	300 kHz to 9 GHz		300 kHz to 9 GHz		300 kHz to 9 GHz	
	±0.3 dB		±0.3 dB		±0.3 dB	
<b>Power Sweep Range</b>	300 kHz to 6 GHz		300 kHz to 6 GHz		300 kHz to 6 GHz	
	25 dB		25 dB		25 dB	
	6 GHz to 9 GHz		20 dB		20 dB	
<b>System Dynamic Range</b>	At test port	Direct receiver <sup>1</sup>	At test port	Direct receiver <sup>1</sup>	At test port	Direct receiver <sup>1</sup>
300 kHz to 25 MHz	125 dB	140 dB	125 dB	140 dB	125 dB	140 dB
25 MHz to 3 GHz	128 dB	143 dB	128 dB	143 dB	128 dB	143 dB
3 GHz to 6 GHz			118 dB	133 dB	118 dB	133 dB
6 GHz to 9 GHz					113 dB	128 dB

Data applies at 25° C ± 5° C. See product literature for more complete specifications and for total measurement uncertainty after error correction.

<sup>1</sup>Characteristic performance attainable with segment sweep mode

**Size:** 222 H x 425 W x 426 D mm (8.75 x 16.75 x 16.8 in)

**Weight:** 24kg (54 lb) net; 32kg (70 lb) shipping

8757D/E

- 75 dB dynamic range
- Optional power calibrator
- 40 dB directivity bridges
- 40 GHz in coax, 110 GHz in waveguide

- Buffered plotter/printer output
- External disk and internal register save/recall
- Built-in limit testing
- Color display

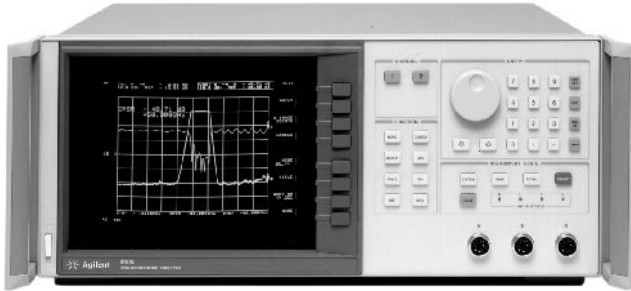

8757E

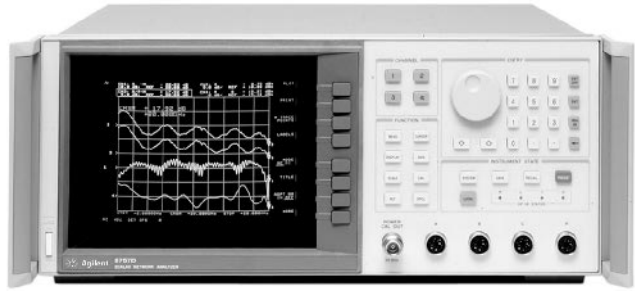

8757D Opt 001, Opt 002

### 8757D/E Scalar Network Analyzers



Measure insertion loss, gain, return loss, SWR, and power quickly and accurately with either the 8757D or 8757E scalar network analyzers. With high-performance detectors and directional bridges, and a companion source and digital plotter, the 8757D and 8757E become the basis of a complete measurement system with superb performance.

5

### A Choice of Two Analyzers

For an economical measurement solution, choose the 8757E scalar network analyzer. The 8757E features three detector inputs and two independent display channels, allowing simultaneous ratioed or non-ratioed measurement of your device's transmission and reflection characteristics, 75 dB dynamic range (+20 to -55 dBm) for measuring high-rejection devices, and a choice between ac (square wave modulated) or dc detection techniques. The internal plotter/printer buffer allows you to send your measurement data directly to a plotter and then proceed to the next measurement, typically in less than five seconds. The 8757E includes a user-friendly interface, and menu-driven, direct-access softkeys, which simplify its operation.

When your application demands maximum system versatility, choose the 8757D scalar network analyzer. It offers all of the performance of the 8757E, plus more standard features, better measurement speed, limit testing, external disk save/recall, and a color display. Limit testing reduces test time by letting the analyzer make quick and objective pass/fail decisions. External disk save/recall allows your measurement state to be preconfigured by an engineer or skilled specialist and then automatically recalled by production technicians. The result is reduced set-up time and greater test integrity at each production station. The precision color display simplifies the separation of measurement information while providing a pleasant display for the technician.

### Increase Absolute Power Measurement Accuracy

For near power meter measurement accuracy, configure a system that includes the 8757D Option 002 and the 85037 series precision detectors. Option 002 on the 8757D adds an internal power calibrator used to characterize the 85037 series detectors' accuracy versus power. In addition, each 85037 series precision detector incorporates a dual-diode detector to improve power measurement accuracy when harmonics are present, plus internal frequency correction factors, read by the 8757D, for more accurate power versus frequency measurements. The result is a system optimized for swept absolute power measurements.

### Systems from 10 MHz to 110 GHz

You can conveniently obtain a 20 GHz coaxial measurement system by ordering the 8757XC (10 MHz to 20 GHz) scalar measurement system. Or, you can configure your own system to 50 GHz in coax or to 110 GHz in waveguide.

The 83750 series synthesized sweeper family offers the accuracy and performance of a synthesized source at an affordable price. When you test narrowband, frequency-selective devices, choose a synthesized sweeper from the 8360 series. These sweepers provide excellent frequency stability and up to 1 Hz frequency resolution.

Feature	8757D	8757E
Display	Color	Monochrome
Display channels	4	2
Detector inputs	3 standard 4 with Option 001	3
Dynamic range	75 dB	75 dB
AC/DC detection mode	Yes	Yes
Measurement points:		
Selectable values	101, 201, 401, 801, 1601	101, 201, 401
Channels displayed	3 or 4	2
Max. points per channel	401	801
Plotter/printer buffer	Yes	Yes
Noise figure display capability*	Yes	Yes
External disk save/recall	Yes	No
Internal save/recall registers	9	9
Limit testing (channels 1 and 2)	Yes	No
Adaptive normalization	Yes	No
Cursor search functions	Max., Min., bandwidth, n dB	Max., Min.
SWR display mode	Yes	Yes
Non-standard sweep mode	Yes	Yes
Auxiliary voltage display mode	Yes	Yes
Optional power calibrator	Yes	No
Compatible with 85037 series precision detectors	Yes	No

\* Product Note 8970 B/S-4, Agilent Literature 5959-8742

**Size:** 178 mm H x 425 mm W x 445 mm D (7 in x 16.75 in x 17.5 in)  
**Weight:** 22kg (48 lb) net; 28kg (61.5 lb) shipping

### Transit Cases

Agilent offers a complete line of sturdy transit cases in Valise and Tote styles. The cases protect your instrument from shock, vibration, moisture, impact, and contamination, providing a secure enclosure for shipping. Model 9211-2650 (standard) or model 9211-7521 (tote) fit the 8757D/E.



### 85037 Series Precision Detectors (ac/dc)

The 85037 series precision detectors are designed specifically for operation with the 8757D scalar network analyzer and may be used in either ac or dc detection modes. These dual diode detectors contain internal frequency correction factors in an internal EE PROM (read automatically by the 8757D) for improved measurement accuracy versus frequency. When used in conjunction with the 8757D's internal power calibrator (Option 002), these detectors provide the maximum absolute power measurement accuracy. The 85037 series detector is not compatible with the 8757E.

#### Absolute Power Measurement Uncertainty Examples

Assumptions:

- Measurement frequency = 10 GHz
- DUT input/output SWR = 1.5
- Measured power = 0 dBm

Uncertainty component	85037B detector	85025E detector
Absolute power accuracy at 50 MHz (±dB)	0.11	0.40
Frequency response (±dB)	0.18	0.50
Mismatch (±dB)	0.18	0.10
Uncertainty Total (±dB)	0.47	1.00

### Reflection Measurement Accuracy

Uncertainties due to calibration error and the frequency response of the source, detectors, and bridges are removed via open/short averaging. The remaining uncertainties are primarily the sum of directivity uncertainty, effective source match uncertainty and dynamic power accuracy. See Technical Data Sheet for further information.

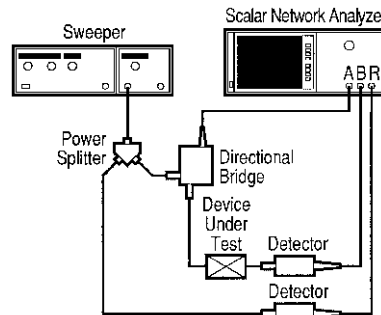

Basic scalar coaxial system configured for ratio reflection and transmission measurements.

### Precision Detector Summary, 85037 Series For use with the 8757D in either ac or dc detection modes

Model	Frequency range	Connector type	Dynamic range	Frequency	Return loss	Frequency response	Power (at 50 MHz)	Dynamic accuracy <sup>1</sup>	Absolute accuracy <sup>2</sup>
85037A <sup>1</sup>	10 MHz to 18 GHz	Type-N (m) 7 mm <sup>2</sup>	ac mode	0.01 to 0.04 GHz	10 dB	±0.35 dB	20 dBm	±0.25 dB	±0.25 dB
			+20 to -55 dBm	0.04 to 18.0 GHz	20 dB	±0.18 dB	10 dBm	±0.11 dB	±0.11 dB
85037B <sup>1</sup>	10 MHz to 26.5 GHz	3.5 mm (m)	ac mode	0.01 to 0.04 GHz	10 dB	±0.35 dB	20 dBm	±0.25 dB	±0.25 dB
			+20 to -55 dBm	0.04 to 18.0 GHz	20 dB	±0.18 dB	10 dBm	±0.11 dB	±0.11 dB
			dc mode	18 to 26.5 GHz	18 dB	±0.22 dB	-30 dBm	±0.11 dB	±0.11 dB
			+20 to -50 dBm				-50 dBm	±0.85 dB	±0.85 dB

### 85025 and 85026 Series Detectors (ac/dc)

The 85025 and 85026 series detectors are designed specifically for operation with the 8757 scalar network analyzer. The 85025/26 detectors detect either a modulated (ac) or an unmodulated (dc) microwave signal.

### 85025C Detector Adapters

The 85025C adapter matches the scalar analyzer display to most standard crystal, silicon and gallium arsenide detectors. This enables the user to operate up to 110 GHz with the 8757. The 85025C detector adapter is designed for use with the 8757 only, and can operate in either ac or dc detection modes.

### Coaxial Detector Summary, 85025 Series For use with the 8757 only in either ac or dc detection modes

Model	Frequency range	Connector type	Dynamic range	Frequency	Return loss	Frequency response	Power (at 50 MHz)	Dynamic accuracy <sup>1</sup>	Absolute accuracy <sup>5</sup>
85025A <sup>3</sup>	10 MHz to 18 GHz	Type-N (m) 7 mm <sup>2</sup>	ac mode	0.01 to 0.04 GHz	10 dB	±0.8 dB	16 dBm	±0.8 dB	±0.8 dB
			+16 to -55 dBm	0.04 to 4 GHz	20 dB	±0.5 dB	6 dBm	±0.4 dB	±0.4 dB
			dc mode	4 to 18 GHz	17 dB	±0.5 dB	-35 dBm	±0.4 dB	±0.4 dB
			+16 to -50 dBm				-50 dBm	±1.3 dB	±1.3 dB
85025B <sup>3</sup>	10 MHz to 26.5 GHz	3.5 mm (m)	ac mode	0.01 to 0.04 GHz	10 dB	±0.8 dB	16 dBm	±0.8 dB	±0.8 dB
			+16 to -55 dBm	0.04 to 4 GHz	20 dB	±0.5 dB	6 dBm	±0.4 dB	±0.4 dB
			dc mode	4 to 18 GHz	17 dB	±0.5 dB	-35 dBm	±0.4 dB	±0.4 dB
			+16 to -50 dBm	18 to 26.5 GHz	12 dB	±2.0 dB	-50 dBm	±1.3 dB	±1.3 dB
85025D <sup>3</sup>	10 MHz to 50 GHz	2.4 mm (m)	ac mode	0.01 to 0.1 GHz	10 dB	±0.8 dB	16 dBm	±1.0 dB	±1.0 dB
			+16 to -55 dBm	0.1 to 20 GHz	20 dB	±0.5 dB	6 dBm	±0.4 dB	±0.4 dB
			dc mode	20 to 26.5 GHz	20 dB	±1.0 dB	-35 dBm	±0.4 dB	±0.4 dB
			+16 to -50 dBm	26.5 to 40 GHz	15 dB	±2.5 dB	-50 dBm	±1.3 dB	±1.3 dB
				40 to 50 GHz	9 dB	±3.0 dB			
85025E <sup>3</sup>	10 MHz to 26.5 GHz	3.5 mm (m)	ac mode	0.01 to 0.1 GHz	10 dB	±0.8 dB	16 dBm	±1.0 dB	±1.0 dB
			+16 to -55 dBm	0.1 to 18 GHz	25 dB	±0.5 dB	6 dBm	±0.4 dB	±0.4 dB
			dc mode	18 to 25 GHz	25 dB	±0.5 dB	-35 dBm	±0.4 dB	±0.4 dB
			+16 to -50 dBm	25 to 26.5 GHz	23 dB	±1.4 dB	-50 dBm	±1.3 dB	±1.3 dB

<sup>1</sup>The 85037A/B specifications are applicable when used with the 8757D scalar network analyzer. The absolute power accuracy and dynamic power accuracy specifications apply after a calibration via the 8757D Option 002's internal power calibrator.

<sup>2</sup>Option 001 changes to a 7-mm connector.

<sup>3</sup>The 85025 and 85026 series detectors and the 85025C detector adapter require 8757A firmware revision 2.0 or higher. To upgrade previous revisions, order the 11614A firmware enhancement.

<sup>4</sup>Dynamic accuracy refers to measurement accuracy as power varies (in dB) from a 0 dBm reference, 25° ±5° C, 50 MHz.

<sup>5</sup>DC mode, 25° ±5° C.

## Waveguide Detectors and Detector Adapters Summary For use with the HP 8757 only in either ac or dc detection modes

Model	Frequency range	Connector type	Dynamic range	Return loss	Frequency response	Dynamic accuracy
<b>R85026A</b> <sup>1</sup>	26.5 to 40 GHz	WR-28	+10 to -50 dBm (ac mode) +10 to -45 dBm (dc mode)	12 dB	±1.5 dB	±(0.3 dB + 0.03 dB/dB)
<b>Q85026A</b> <sup>1</sup>	33 to 50 GHz	WR-22	+10 to -50 dBm (ac mode) +10 to -45 dBm (dc mode)	12 dB	±2.0 dB	±(0.3 dB + 0.03 dB/dB)
<b>U85026A</b>	40 to 60 GHz	WR-19	+10 to -50 dBm (ac mode) +10 to -45 dBm (dc mode)	12 dB	±2.0 dB	±(0.3 dB + 0.03 dB/dB)
<b>85025C Option K57</b> <sup>2</sup>	50 to 75 GHz	WR-15	+10 to -45 dBm (typical)	9.5 dB (typical)	—	—
<b>85025C Option K71</b> <sup>3</sup>	75 to 110 GHz	WR-10	+10 to -45 dBm (typical)	9.5 dB (typical)	—	—
<b>85025C</b> <sup>1</sup>	<sup>2</sup>	SMA (m)	<sup>2</sup>	<sup>2</sup>	<sup>2</sup>	<sup>2</sup>

<sup>1</sup>The 85025 and 85026 series detectors and the 85025C detector adapter require 8757A firmware revision 2.0 or higher. To upgrade previous revisions, order the 11614A firmware enhancement.

<sup>2</sup>Depends upon the particular detector being used.

<sup>3</sup>Must be used with the 85025C detector adapter.

### 85027 Series Directional Bridges (ac/dc)

The 85027 series directional bridges are designed to operate with either the 8757 in ac or dc detection modes. These bridges offer high directivity, excellent test port match, and a measurement range of up to 50 GHz in coax.

### 8757D Option 002 Power Calibrator

The 8757D's internal power calibrator provides a 50 MHz reference standard for characterizing the absolute power accuracy and dynamic power accuracy of the 85037 series precision detectors.

- Frequency:** 50 MHz ±0.2 MHz
- Accuracy at 0 dBm:** ±0.05 dB
- Linearity:** (over any 10 dB range)
  - ±0.08 dB (+20 to +10 dBm)
  - ±0.04 (+10 to -30 dBm)
  - ±0.06 (-30 to -50 dBm)

## Directional Bridge Summary For use with the HP 8757 in ac or dc detection mode

Model	Frequency range	Nominal impedance	Connector—input	Connector—test port	Frequency	Directivity (dB)	Frequency	Test port match (SWR)
<b>85027A</b>	10 MHz to 18 GHz	50 Ω	Type-N (f)	7 mm	0.01 to 18 GHz	40 dB	0.01 to 8.4 GHz 8.4 to 12.4 GHz 12.4 to 18 GHz	<1.15 <1.25 <1.43
<b>85027B</b>	10 MHz to 26.5 GHz	50 Ω	3.5 mm (f)	3.5 mm (f)	0.01 to 20 GHz 20 to 26.5 GHz	40 dB 36 dB	0.01 to 8.4 GHz 8.4 to 20 GHz 20 to 26.5 GHz	<1.15 <1.43 <1.78
<b>85027C</b>	10 MHz to 18 GHz	50 Ω	Type-N (f)	Type-N (f)	0.01 to 12.4 GHz 12.4 to 18 GHz	36 dB 34 dB	0.01 to 8.4 GHz 8.4 to 12.4 GHz 12.4 to 18 GHz	<1.15 <1.25 <1.43
<b>85027D</b>	10 MHz to 50 GHz	50 Ω	2.4 mm (f)	2.4 mm (m)	0.01 to 20 GHz 20 to 26.5 GHz 26.5 to 40 GHz 40 to 50 GHz	36 dB 32 dB 30 dB 25 dB	0.01 to 16 GHz 16 to 30 GHz 30 to 40 GHz 40 to 50 GHz	<1.18 <1.27 <1.57 typically <2.00
<b>85027E</b>	10 MHz to 26.5 GHz	50 Ω	3.5 mm (f)	3.5 mm (m)	0.01 to 20 GHz 20 to 26.5 GHz	40 dB 36 dB	0.01 to 8.4 GHz 8.4 to 20 GHz 20 to 26.5 GHz	<1.15 <1.43 <1.78

## System Accuracy

### Transmission Loss or Gain Measurement Accuracy

Transmission loss or gain measurements are made relative to a 0 dB reference point established at calibration. Transmission measurement uncertainty = dynamic power accuracy + mismatch uncertainty.

Dynamic power accuracy is the measurement uncertainty due to the change in power level between calibration and the measurement. Mismatch uncertainty is the uncertainty due to reflections in the measurement setup. The frequency response errors of the source, detectors, bridge and power splitter are removed via calibration.

### Transmission Measurement Uncertainty Examples

Assumptions:

- Measurement frequency = 10 GHz
- DUT input/output SWR = 1.5
- Change in power after calibration <30 dB (+0 to -30 dBm range)

Uncertainty component	85037B precision detector	85025E detector
Dynamic accuracy (±dB)	0.11	0.40
Mismatch (±dB)	0.45	0.33
Uncertainty Total (±dB)	0.56	0.73



11679A



85022A

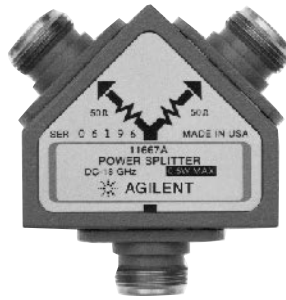

11667A



11667C

11679A  
11679B  
85022A  
8757D  
8757E  
11636A  
11636B  
11852B  
11667A  
11667B  
11667C

### 11679A/B Extension Cables

#### Function

These cables extend the distance between the scalar network analyzer and the detector or bridge to a maximum of 200 feet without degradation of performance.

**11679A:** 7.6 m (25 ft) extension cable

**11679B:** 61 m (200 ft) extension cable

### 85022A System Cable Kit

The 85022A contains all the BNC and GPIB cables to connect an Agilent sweep oscillator (8360 series, 83750, or 83751 synthesized sweepers), an HP computer and a printer to the 8757. This kit contains three one-meter GPIB cables (10833A), three two-foot BNC (m-m) cables (11170B) and one four-foot BNC (m-m) cable (11170C).

**BNC Impedance:** 50 Ω

**Weight:** Net, 0.5 kg (1.2 lb); shipping, 1.2 kg (2.9 lb)

### 11636A/B Power Dividers

The 11636A/B power dividers/combiners are recommended when making wideband comparison measurements without ratioing.

### 11613B Calibrator

The 11613B is a dedicated transfer standard for calibration of the 8757D/E scalar network analyzers. The 11613B provides a standard, a 27.778 kHz source and a series of precision attenuators. The calibrator includes software that verifies (and adjusts if necessary) the internal calibration parameters stored in the nonvolatile memory of the analyzer.

An HP Series 200 or 300 computer is required for operation. The computer must have BASIC 2.0 or greater and 512K bytes of RAM. For use with the 8756A Scalar Analyzer, the computer also requires the HP 98622A 16-bit GPIO card.

### 11852B 50 Ω/75 Ω Minimum-Loss Pad

The 11852B is a low SWR minimum-loss pad required between 75 Ω devices and 50 Ω sources and detectors. For more information, see page 313.

### 11667A/B/C Power Splitters

The 11667A/B/C power splitters are recommended when making wideband ratio measurements using the 8757 scalar network analyzer. These two-resistor type splitters provide excellent output SWR at the auxiliary arm when used for source leveling or ratio measurement applications. The tracking between output arms over a frequency range from dc to 50 GHz allows wideband measurements to be made with a minimum of uncertainty.

#### Frequency Range

**11667A:** DC to 18 GHz

**11667B:** DC to 26.5 GHz

**11667C:** DC to 50 GHz

**Impedance:** 50 Ω nominal

#### Insertion Loss

**11667A/B:** 6 dB nominal

**11667C:** 8.5 dB nominal

**Max. Input Power:** +27 dBm

#### Connectors

**11667A:** N-female on all ports

**11667B:** 3.5-mm female on all ports

**11667C:** 2.4-mm female on all ports

### 8757D Upgrade Kits

Increase your analyzer's measurement capability and performance with an 8757 upgrade kit.

The 86383C upgrade kit allows you to add the fourth detector input to your 8757D (86383C Option 001) and/or the internal power calibrator (86383C Option 002). Installation is not included with this kit.

### Key Literature

8757D/E Scalar Network Analyzers Brochure, p/n 5091-2469E

8757D/E Scalar Network Analyzers Technical Data, p/n 5091-2471E

8757D/E Scalar Network Analyzers Configuration Guide, p/n 5967-6177E

8757 System  
8757XC

The 8757 scalar network analyzer is ordered with multiple line items to give you maximum flexibility in specifying a system that meets your needs. Consult your local Agilent Technologies sales office if you would like assistance.

### Ordering Information

#### Complete Measurement System<sup>2</sup>

**8757XC** 20 GHz Coaxial Synthesized Scalar System

Includes: 8757D Scalar Network Analyzer, 83752A

Synthesized Sweeper<sup>1</sup>, and 85022A Cable Kit

**Opt 001** Adds Fourth Detector Input to Analyzer

**Opt 002** Adds 50 MHz Calibrator to Analyzer

**Opt 1E1** Adds 70 dB Step Attenuator to Source

**Opt 1E5** Adds High-Stability Timebase to Source

**Opt 1ED** Adds Type-N Connector to Source

**Opt 57E** Substitutes 8757E Analyzer

**Opt 51A** Substitutes 83751A Source  
(2 to 20 GHz)

**Opt 51B** Substitutes 83751B Source  
(2 to 20 GHz, high power)

**Opt 52B** Substitutes 83752B Source  
(0.01 to 20 GHz, high power)

#### Analyzer

**8757D** Scalar Network Analyzer

**Opt 001** Fourth Detector Input

**Opt 002** Internal Power Calibrator

**Opt W30** Two-Year Extended Service

**Opt 1BN** MIL-STD-45662A Calibration  
Certificate

**Opt 1BP** MIL-STD-45662A Calibration with  
Test Data

**Opt UK6** Commercial Calibration Certificate w/data

**8757E** Scalar Network Analyzer

**Opt 1BP** MIL-STD-45662A Calibration with Test Data

#### Sweepers

Choose the 83752A/B synthesized sweepers for applications from 10 MHz to 20 GHz, or the 8360 series synthesized sweepers for measurements up to 50 GHz in coax or 110 GHz in waveguide.

#### Precision Detectors

**85037A** 0.01 to 18 GHz, Type-N(m)

**Opt 001** 7-mm Connector

**85037B** 0.01 to 26.5 GHz, 3.5 mm(m)

#### Directional Bridges

**85027A** 0.01 to 18 GHz, 7 mm, 50 Ω

**85027B** 0.01 to 26.5 GHz, 3.5 mm (f), 50 Ω

**85027C** 0.01 to 18 GHz, Type-N (f), 50 Ω

**85027D** 0.01 to 50 GHz, 2.4 mm (m), 50 Ω

**85027E** 0.01 to 26.5 GHz, 3.5 mm (m), 50 Ω

<sup>1</sup>In addition to the options listed, the 83752A can be substituted with any other Agilent synthesized source. For more information contact the Agilent Call Center in your region.

<sup>2</sup>Must order power splitter, detectors, and bridge separately.

#### Detectors

**85025A** 0.01 to 18 GHz, Type-N (m)

**Opt 001** 7-mm Connector

**85025B** 0.01 to 26.5 GHz, 3.5 mm (m)

**85025D** 0.01 to 50 GHz, 2.4 mm (m)

**85025E** 0.01 to 26.5 GHz, 3.5 mm (m)

**R85026A** 26.5 to 40 GHz, WR-28 Waveguide

**Q85026A** 33 to 50 GHz, WR-22 Waveguide

**U85026A** 40 to 60 GHz, WR-19 Waveguide

**85025C** Detector Adapter

#### System Cable Kit

**85022A** System Cable Kit

#### Optional Accessories

(For ratio and/or modulation measurements)

**11636A** Power Divider dc to 18 GHz

**11636B** Power Divider dc to 26.5 GHz

**11667A** Power Splitter dc to 18 GHz

**Opt 001** N-male on Input Port; N-female  
on Output Ports

**Opt 002** N-female on Input Port; 7 mm  
on Output Ports

**11667B** Power Splitter dc to 26.5 GHz

**11667C** Power Splitter dc to 50 GHz

**11679A** Detector Extension Cable, 7.6 m (25 ft)

**11679B** Detector Extension Cable, 61 m (200 ft)

**11852B** 50 to 75 Ω Minimum Loss Pad

#### Upgrade Kits

**86383C** Upgrade Kit for 8757D

**Opt 001** Adds Fourth Detector Input

**Opt 002** Adds Internal Power Calibrator

#### Transit Cases

**9211-2650** Standard Transit Case

**9211-7521** Tote-Style Transit Case

For information on compatible printers, visit our web site:

<http://www.agilent.com/find/pcg>

 Indicates QuickShip availability.





- 10 kHz to 300 MHz
- 0.04 ms/point measurement speed
- Fine resolution IFBW
- List sweep function
- Stable measurements

- High-speed evaluation using the waveform analysis commands
- Evaporation Monitoring Function (Option)
- Phase Tracking Function (Option)
- Supports active probes (Option)
- GP Instrument BASIC for easy automation

E5100A  
E5100B

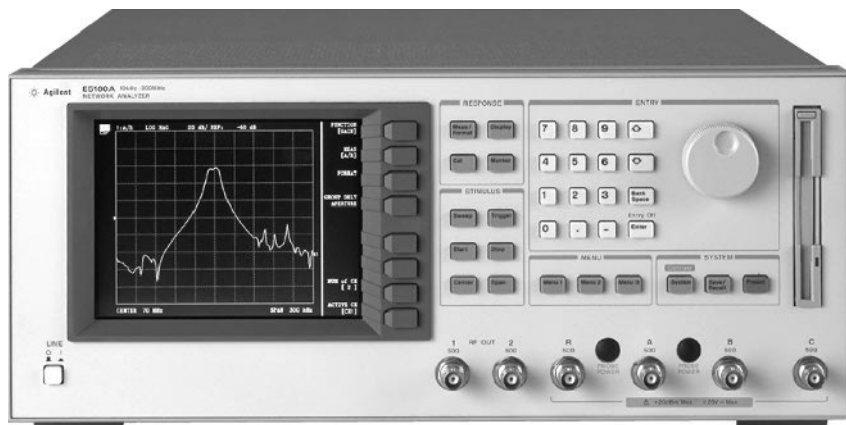

E5100A/B

### E5100A/B Network Analyzers



The E5100A/B network analyzer is a 10 kHz to 300 MHz network analyzer best fitted for production lines of electronic component manufacturers, especially resonator and filter manufacturers, who require extra-high throughput.

The E5100A/B improves production line productivity with its fast measurement speed (fastest sweep speed is 0.04 ms/point), fast waveform analysis commands, and speedier processor. It provides faster measurements with lower fluctuations because of its low-noise performance and fine selection IFBW.

#### E5100A

The E5100A is a versatile network analyzer with many functions and options to fit your needs with a minimum investment. During final tests, both precision and high speed are required for better yield and better productivity. The E5100A makes high-quality and high-speed tests with its fine IFBW selection and low-noise circuitry. Its convenient analysis and processing functions improve the productivity of the final test processes.

#### E5100A 180MHz Version

The E5100A 180 MHz version (option 118/218/318/618) is the economical solution for lower frequency applications. The frequency range is 10 kHz to 180 MHz. The E5100A 180 MHz version provides the same measurement performance as the 300 MHz version with lower price.

#### E5100B

The E5100B is best for in-process testing of filters and resonators. The requirement of in-process testing is different from that of final tests; they need fast measurements and low price. The E5100B has the same measurement quality and speed as the E5100A, but has reduced functionality. The E5100B reduces production costs and is a valuable tool for in-process testing.

Model	E5100A 300MHz version	E5100A 180MHz version	E5100B
Frequency range	10kHz to 300MHz	10kHz to 180MHz	10kHz to 300MHz
Number of receivers	1 to 4	1 to 3	1 to 2
Number of points	1601	1601	401
List sweep	yes	yes	no
Dynamic range	120 dB	120 dB	100 dB
Phase tracking function	yes (Opt 023)	yes (Opt 823)	no
Evaporation monitor function	yes (Opt 022)	no	yes (Opt 022)

### Specifications

#### Source Characteristics

##### Frequency

**Range:** 10 kHz to 300 MHz, 10 kHz to 180 MHz (E5100A with Opt. 118/218/318/618)

##### Output

**Power range (at SINGLE):** -48 to +22 dBm (option), -9 to +11 dBm (standard)

**Resolution:** 0.1 dB

#### Receiver Characteristics

##### Frequency

**Range:** 10 kHz to 300 MHz, 10 kHz to 180 MHz (E5100A with Opt. 118/218/318/618)

**IFBW:** 10 Hz to 30 kHz (1, 1.5, 2, 3, 4, 5, 8 steps)

**Input Impedance (nominal):** 50 Ω (std.), 50 Ω / 1M Ω, 30 pF (option)

**Dynamic Range:** >120 dB (IFBW = 1 kHz)

**Dynamic Accuracy:** ±0.05 dB, ±0.3 deg

**Measurement Speed:** 0.04 ms/point (IFBW = 30 kHz, ramp-sweep)

#### General Characteristics

**Measurement Parameters:** Gain (Amplitude Ratio), Phase, Group-Delay, Amplitude, Gain-Phase, Gain-Delay Impedance, Admittance

**Display:** 6.5 inch TFT Color LCD

**Programming:** IBASIC

**Mass Storage:** FDD and internal non-volatile memory

**Parallel I/O Port:** TTL, 16-bit output, 8-bit input/output (standard)

**Power Requirement:** 90 to 132V or 198 to 264V, 47 to 63 Hz, 400VA max.

**Size:** 177 mm H x 425 mm W x 425 mm D (7.08 in x 17 in x 17 in)

**Weight:** 12 kg (26.4 lb) (typical)

#### Key Literature

E5100A/B Network Analyzer Product Overview, p/n 5968-1873E

E5100A/B Technical Specifications, p/n 5966-2888E

### E5100A/B Accessories

#### 41901A SMD PI-Network Test Fixture

The 41901A SMD PI-network test fixture produces the capability to measure surface-mount crystal resonator using the E5100A/B. Attachment kit (option) is required for measurement. The frequency range of the 41901A is 1 MHz to 300 MHz.



### Ordering Information

#### E5100A Network Analyzer

- Opt 100** 300MHz 1 Receiver, Port A
- Opt 200** 300MHz 2 Receivers, Port R and A
- Opt 300** 300MHz 3 Receivers, Port R, A and B
- Opt 400** 300MHz 4 Receivers, Port R, A, B and C
- Opt 600** 300MHz PI-Network Test Ready Package
- Opt 118** 180MHz 1 Receiver, Port A
- Opt 218** 180MHz 2 Receiver, Port R and A
- Opt 318** 180MHz 3 Receiver, Port R, A and B
- Opt 618** 180MHz PI-Network Test Ready Package
- Note: Choose one Option from 100 to 618 depending on test frequency range and number of receivers.
- Note: Options 600 and 618 include power-extended two RF OUT ports and two receivers.
- PI-network fixture is not included.
- Opt 001** One RF OUT port
- Opt 002** Two RF OUT ports, built-in power splitter
- Opt 003** Two RF OUT ports, switched single output
- Note: Choose one Option from 001 to 003 except the case of Options 600 and 618. Option 003 cannot be ordered with Option 101 or 301.
- Opt 101** 50Ω/1MΩ selectable input on Port A
- Opt 102** Type-N input connector on Port A
- Note: Options 101 and 102 are for Options 100, 200, 118 and 218 only. Option 101 cannot be ordered with Option 003.
- Opt 301** 50Ω/1MΩ selectable inputs on Ports A and B
- Opt 302** Type-N input connector on Port A and B
- Note: Options 301 and 302 are for Options 300, 400 and 318 only. Option 301 cannot be ordered with Option 003.
- Opt 010** Extended Output Power Range
- Opt 022** Evaporation Monitoring Function
- Note: Option 022 cannot be ordered with Options 118, 218, 318 and 618.
- Opt 023** Phase Tracking Function for 300MHz version
- Note: Option 023 is for Options 100, 200, 300, 400 and 600 only. Option 023 cannot be ordered with Options 118, 218, 318 and 618.

- Opt 823** Phase Tracking Function for 180MHz version
- Note: Option 823 is for Options 118, 218, 318 and 618 only. Option 823 cannot be ordered with Options 100, 200, 300, 400 and 600.
- Opt 1D5** High-stability Frequency Reference
- Opt 005** Parallel I/O, mode A
- Opt 006** Parallel I/O, mode B
- Opt 007** Opto-isolated Parallel I/O
- Note: 24-bit parallel I/O is furnished in standard. Select only one of Options 005, 006, 007, or choose none.
- Opt UKR** Delete IBASIC
- Opt 1F0** Add IBASIC Keyboard

#### E5090A 2-Port Transmission/Reflection Test Kit

The E5090A 2-port transmission/reflection test kit provides the capability to measure transmission and reflection characteristics of two port device in either direction with a single connection. The E5090A is test set for the E5100A with Options 003, 010, 302, and 400. The frequency range of the E5090A is dc to 2 GHz.

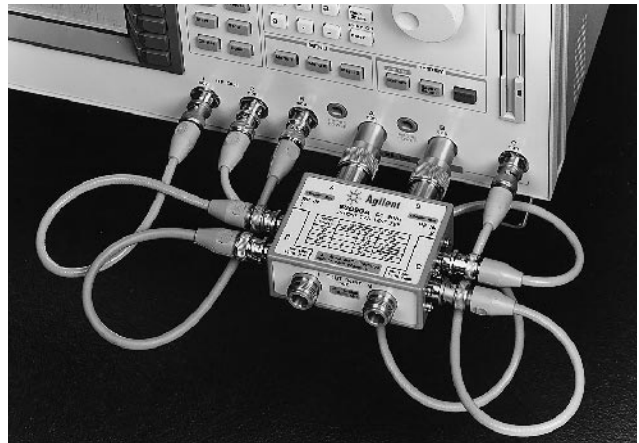

#### E5100B Network Analyzer

- Opt 100** 1 Receiver, Port A
- Opt 200** 2 Receivers, Ports R and A
- Note: Must choose either Option 100 or 200.
- Opt 001** Single RF OUT port
- Opt 002** Dual RF OUT ports, built-in power splitter
- Note: Must choose either Option 001 or 002.
- Opt 010** Extended output power range, -48 to +22 dBm
- Opt 022** Evaporation Monitoring Function
- Opt 101** 50 Ω/1 MΩ selectable input, Port A
- Opt 102** Type-N input connector, Port A
- Opt 1D5** High-Stability Frequency Reference
- Opt 005** Parallel I/O mode A
- Opt 006** Parallel I/O mode B
- Opt 007** Opto-isolated Parallel I/O
- Note: 24-bit parallel I/O is furnished, select only one of Options 005, 006, 007, or choose none.
- Opt UKR** Delete IBASIC
- Opt 1F0** Add DIN Keyboard

#### Accessories

- 41800A** Active Probe
- 41802A** 1-MΩ Input Adapter
- 41900A** PI-Network Test Fixture
  - Opt 001** Adapter Kit for Load Capacitor
- 41901A** SMD PI-Network Test Fixture
  - Opt 010 to 061** Attachment Kit
- E5090A** 2-Port Transmission/Reflection Test Kit
- 11850C** 50 Ω Three-Way Power Splitter

- 300 kHz to 1.3 GHz (8712ET/ES) or 3 GHz (8714ET/ES)
- S-parameter measurements (ES models)
- Up to 100 dB dynamic range
- Narrowband and broadband detection
- Real-time sweep speeds
- 50  $\Omega$  or 75  $\Omega$  system impedance
- 1 Hz resolution synthesized source
- Standard LAN interface
- Standard GP Instrument BASIC (IBASIC)
- Optional fault-location and SRL measurements
- Standard multiport test sets available

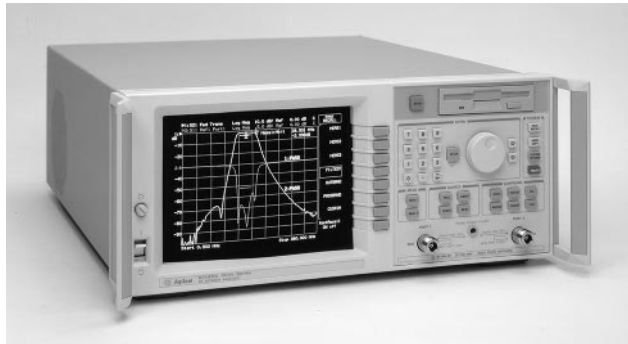

8712E RF Network Analyzer Series

## 8712E RF Network Analyzer Series



### Designed for Manufacturing

The 8712E Series of economical RF network analyzers provides speed, accuracy, and automation features in compact, integrated instruments for high-volume RF component manufacturing. These analyzers help reduce tune and test times, increase throughput, and lower your overall cost per component. A choice of transmission/reflection analyzers (ET models) or S-parameter analyzers (ES models) allows you to choose the optimum level of performance versus price to meet your measurement needs.

### Standard Family Features

The 8712ET and 8714ET feature built-in transmission/reflection test sets with a full range of magnitude and phase measurements. These analyzers also employ advanced vector-error correction techniques to enhance measurement accuracy.

The 8712ES and 8714ES feature S-parameter test sets with full two-port vector-error correction, providing the highest level of measurement accuracy.

All these analyzers provide fast, complete swept-frequency and swept-power characterization of RF components. In addition:

- 300 kHz to 1.3 or 3 GHz models are available in both 50  $\Omega$  or 75  $\Omega$  options
- A synthesized source provides fast, stable, high-resolution (1 Hz) stimulus for accurate measurements on a variety of RF components
- Power sweeps enable testing of amplifier gain compression and AM-PM conversion.
- A 60 dB step attenuator (standard on ES models, optional on ET models) provides a wide range of output power levels for testing active devices
- Real-time sweep speeds with better than 10 updates per second facilitate high device throughput and increase tuning efficiency
- A built-in 3.5-inch DOS-format disk drive provides unlimited data storage
- Serial, parallel, LAN and GPIB interfaces make it easy to print or plot data to all printers and plotters

Flexible, sensitive receivers offer a choice between narrowband and broadband detection. Broadband detection allows scalar characterization of frequency-translating devices, while narrowband detection provides up to 100 dB of dynamic range for vector measurements of high-rejection devices.

The instruments are equipped with a large, 9-inch monochrome display for clear view of measurement data, softkey functions, IBASIC programs, and markers. Display pass/fail indicators and trace data in color by connecting any VGA-compatible monitor. Two independent measurement channels let you display transmission and reflection data simultaneously. Each channel can have independent measurement parameters such as frequency range, IF bandwidth, number of points, and display formats. Display formats include SWR, linear and log magnitude, phase and group delay, Smith chart, polar, real and imaginary, dBW, dBm, dB $\mu$ W, dBV, dBmV, and dB $\mu$ V.

### Manufacturing Features

A network connection provides an efficient and reliable way to communicate with your test systems. The standard TCP/IP-compliant Ethernet LAN interface makes connecting to a factory-wide network easy. Use a variety of standard protocols, such as ftp, http, bootp, telnet, sockets, and network file system (NFS) to simultaneously distribute new test programs, test parameters, limit lines, and custom interfaces to all of the instruments on your production lines. With LAN capability, data can be directly imported into your PC applications, such as Microsoft Word, and Excel, or sent to a networked printer. You can also remotely troubleshoot test station problems from anywhere on the network by using any standard web browser.

With Instrument BASIC programming language (IBASIC), you can easily create custom test applications and user interfaces that include:

- Special softkey labels, graphical setup diagrams, and tailored user prompts
- Bar-code-reading capability for efficient tracking and documentation of individual device performance
- Control other test instruments via the LAN, GPIB, serial, or parallel interfaces
- For simpler applications, even those without programming expertise can use IBASIC as a keystroke recorder, to easily automate manual measurements.

Many manufacturing tests can be accomplished by merely recalling the appropriate instrument state, eliminating the need to change measurement parameters manually. Hundreds of instrument states can be programmed for a variety of uses. With Agilent's "fast-recall" feature, one of seven instrument states can be quickly recalled with a single softkey, or with a footswitch for hands-free switching during aligning or assembly operations.

Instrument states can include user-defined limit lines that let you easily and consistently compare measured data to test limits, providing automated pass/fail testing. The pass/fail results are displayed clearly on the instrument screen or external monitor to minimize operator errors or misinterpretation. Automated pass/fail testing eliminates the guesswork from your test processes and helps ensure that your components are aligned and tested to the same specifications at all test stations.

Speed up component test times by using the power of built-in data markers. Use the eight markers per channel to display data in absolute or relative terms. Or, perform automatic, real-time calculations of device characteristics such as maximum/minimum, center frequency, mean and standard deviation, peak-to-peak excursion, gain, slope and flatness, and filter 3-dB bandwidth, loss, and Q.

### Comprehensive, Fast Cable Test

Option 100 adds fault-location and structural-return-loss (SRL) measurement capability for characterizing 50  $\Omega$  or 75  $\Omega$  cables that are still on a spool in a warehouse, or already installed on a cellular tower.

Agilent's fault-location option is easy to use and has many advantages over traditional time-domain reflectometry (TDR) techniques. You can also use the option to easily characterize the loss and velocity factors of your cables, and to accurately check the effect of cable damage by measuring SRL. Option 101 combines Option 100 with a rugged transport case to protect your instrument in the field during transport and operation.

8712ET  
8712ES  
8714ET  
8714ES

5

8712ET  
8712ES  
8714ET  
8714ES  
87050E  
87075C



87050E Option 12 and 8714ES

## 87050E and 87075C Multiport Test Sets

The 87050E (50 ohm) and the 87075C (75 ohm) multiport test sets are designed to work with the 8712E series of RF vector network analyzers to provide complete multiport measurement systems. The 87050E has specified performance from 3 MHz to 2.2 GHz, with typical performance to 3 GHz. The 50 ohm test set is offered in 4, 8 and 12-port options. The 87075C has a frequency range of 3 MHz to 1.3 GHz and is offered in 6- and 12-port options.

These systems dramatically increase measurement throughput by minimizing RF connections. Connect your device one time to measure all signal paths and ports. Reduce operator fatigue, mis-connection rates, and the wear on cables, fixtures, and connectors as well. In addition, the 8712E series of network analyzers provides many productivity features that speed tune and test times, increase throughput, and simplify automation.

An 87050E or an 87075C coupled with an 8712E series network analyzer is the only low-cost, multiport test system with fully specified performance at the actual test ports, whether you measure in a fixture or at the end of test cables. Specified performances means you get the same measurement results on any test station, reduce measurement uncertainty to tighten your product specifications, and increase customer confidence in your products.

## Innovative new calibration techniques save time and increase accuracy

Test Set Cal is an advanced calibration technique that eliminates the redundant connection of standards during a system calibration. Calibrating a multiport test set using two-port error correction and a traditional network analyzer requires a unique instrument state for each measurement path, forcing many redundant connections of calibration standards. As the number of ports increases, so does the number of connections required to calibrate all possible measurement paths. Full calibration of the 87050E and 87075C multiport test systems is quick and simple when performing a Test Set Cal:

- Connect short, open, and load standards only once to each measurement port
- Minimize the number of through standards required during calibration

In between Test Set Cals, the system can quickly recalibrate itself by using SelfCal. SelfCal is an internally automated calibration technique that uses solid-state switches to measure calibration standards located inside the test set. The network analyzer's firmware automatically controls the SelfCal process at an interval you define. SelfCal re-calibrates your multiport system to the same measurement accuracy achieved immediately after performing a Test Set Cal, thus reducing the effects of test-system drift and improving overall measurement accuracy between Test Set Cals. Using Test Set Cal and SelfCal, you can:

- Easily reduce your overall calibration times by a factor of twenty or more
- Increase the amount of time a test station can be used for measuring devices – typically, by three days per month!

Agilent-qualified Channel Partners provide measurement hardware and software solutions that combine with Agilent's network analyzer products to offer a complete solution for your testing needs. For additional information, please refer to page 337.



### Detectors and Bridges

External detectors (50 Ω and 75 Ω) are available for remote device measurements.

#### 86200B 50 Ω Scalar Detector

An external scalar detector for measuring 50 Ω devices.

#### 86201B 75 Ω Scalar Detector

An external scalar detector for measuring 75 Ω devices.

### Upgrade Kits

The following upgrade kits add optional measurement capability to existing 8712E series RF network analyzers.

To order, add a “U” to the end of the model number of the instrument to be upgraded, and specify one or more of these options:

#### Option 1E1 50 Ω Step Attenuator

Provides the necessary components to retrofit an 8712ET or 8714ET with a 60 dB step attenuator (for 50 ohm models only). Does not include installation. Requires recalibration.

#### Option UNE 75 Ω Step Attenuator

Provides the necessary components to retrofit an 8712ET or 8714ET with a 60 dB step attenuator (for 75 ohm models only). Does not include installation. Requires recalibration.

#### Option 099 Firmware Upgrade

Upgrade to the latest version of firmware. Does not include installation.

#### Option 100 Fault Location/SRL

Provides cable-measurement software. Does not include transport case. Does not include installation.

#### Option 101 Transport and Operating Case and Fault Location/SRL

Combines transport and operation case with Option 100. Does not include installation.

#### Transit Cases

Agilent offers a complete line of sturdy transit cases in Valise and Tote styles. The cases protect your instrument from shock, vibration, moisture, impact, and contamination, providing a secure enclosure for shipping. Model 9211-2656 (standard) or model 9211-7481 (tote) fit the 8712ET/ES and 8714ET/ES.

#### Key Literature

8712ET/ES and 8714ET/ES Brochure, p/n 5967-6316E  
 8712ET/ES and 8714ET/ES Technical Specifications, p/n 5967-6314E  
 8712ET/ES and 8714ET/ES Configuration Guide, p/n 5967-6315E  
 87050E Brochure, p/n 5968-4763E  
 87050E Technical Specifications, p/n 5968-4764E  
 87050E Configuration Guide, p/n 5968-4765E  
 87075C Brochure, p/n 5968-4766E  
 87075C Technical Specifications, p/n 5968-4767E  
 87075C Configuration Guide, p/n 5968-4768E

For more information, visit our web site:  
<http://www.agilent.com/find/ena>

8712ET  
 8712ES  
 8714ET  
 8714ES

5

	8712ET 8712ES		8714ET 8714ES	
<b>Impedance</b>	50 ohm	75 ohm (Option 1EC)	50 ohm	75 ohm (Option 1EC)
<b>Minimum frequency</b>	300 kHz	300 kHz	300 kHz	300 kHz
<b>Maximum frequency</b>	1.3 GHz	1.3 GHz	3.0 GHz	3.0 GHz
<b>Frequency resolution</b>	1 Hz	1 Hz	1 Hz	1 Hz
<b>Max. source power</b> ET (<1 GHz/>1 GHz) with Option 1E1 ES (<1 GHz/>1 GHz)	16 dBm/13 dBm 15 dBm/12 dBm 13 dBm/10 dBm	13 dBm/10dBm 12 dBm/9 dBm 10 dBm/7dBm	11 dBm/10dBm 10 dBm/9 dBm 9 dBm/7dBm	8 dBm/7dBm 7 dBm/6dBm 6 dBm/4dBm
<b>Min. source power</b> ET with Option 1E1 ES	0 dBm -60 dBm -60 dBm	-3 dBm -60 dBm -60 dBm	-5 dBm -60 dBm -60 dBm	-8 dBm -60 dBm -60 dBm
<b>Power resolution</b>	0.01 dBm	0.01 dBm	0.01 dBm	0.01 dBm
<b>Power flatness</b> ET with Option 1E1 ES	± 1.0 dB ± 2.0 dB ± 2.0 dB	± 1.5 dB ± 3.0 dB ± 3.0 dB	± 1.0 dB ± 2.0 dB ± 2.0 dB	± 1.5 dB ± 3.0 dB ± 3.0 dB
<b>Power sweep range</b>	13 dB	13 dB	15 dB	15 dB
<b>System dynamic range</b> ET (narrowband/broadband) with Option 1E1 ES (narrowband/broadband)	>115 dB/>62 dB >115 dB/>60 dB >104 dB/>46 dB	>113 dB/>56 dB >110 dB/>53 dB >99 dB/>39 dB	>114 dB/>59 dB >112 dB/>57dB >101 dB/>43 dB	>110 dB/>53 dB >107 dB/>50 dB >96 dB/>36 dB
<b>Test port connector</b>	Type-N (f)	Type-N (f)	Type-N (f)	Type-N (f)

Data applies at 25° C ±5° C. See product literature for more complete specifications and for total measurement uncertainty after error correction.

**Size:** 179 mm H x 425 mm W x 514 mm D (7.0 in x 16.75 in x 20.25 in)  
**Weight:** 20.5 kg (45 lb) net; 27 kg (59 lb) shipping

8712ET  
8712ES  
8714ET  
8714ES  
87050E  
87075C

## Ordering Information

Note: A complete system consists of a network analyzer, calibration kit, and cables. Calibration kits and cables can be found in the Accessories section beginning on pg. 299.

**8712ET** Network Analyzer  
**8712ES** Network Analyzer  
**8714ET** Network Analyzer  
**8714ES** Network Analyzer

The following options apply to all three network analyzers:

- Opt 1EC** 75  $\Omega$  Impedance
- Opt 1E1** 60 dB Attenuator (ET models only)
- Opt 1CL** DIN Keyboard
- Opt 1CM** Rackmount Kit
- Opt 100** Fault Location/SRL
- Opt 101** Transport and Operating Case plus Fault Location/SRL
- Opt AFN** 50  $\Omega$  Economy Cable
- Opt AFP** 75  $\Omega$  Economy Cable
- Opt B20** 50  $\Omega$  Precision Cable
- Opt B21** 75  $\Omega$  Precision Cable

**87050E** Multiport Test Sets

- Opt 004** 4 ports
- Opt 008** 8 ports
- Opt 012** 12 ports

**87075C** Multiport Test Sets

- Opt 006** 6 ports
- Opt 012** 12 ports

**Upgrades for ET and ES models (Add "U" to model number)**

- Opt 1E1** 50  $\Omega$  Step Attenuator (ET only)
- Opt UNE** 75  $\Omega$  step attenuator (ET only)
- Opt 099** Firmware Upgrade Kit
- Opt 100** FL/SRL Upgrade Kit
- Opt 101** Transport Operating Case plus FL/SRL Upgrade Kit

**Upgrades for C models**

- 86226C** Firmware Upgrade Kit
- 86227C** LAN Upgrade Kit

**Accessories**

- 86200B** 50  $\Omega$  Scalar Detector
- 86201B** 75  $\Omega$  Scalar Detector

**Transit Cases**

- 9211-2656** Standard Transit Case
- 9211-7481** Tote-Style Transit Case

- 30 kHz to 3 or 6 GHz frequency range
- Integrated T/R or S-parameter test set
- Up to 110 dB dynamic range
- Large LCD display with VGA output for external monitors
- Display up to four parameters at the same time
- Save/recall instrument states and data to built-in floppy-disk drive
- Optional time-domain and swept-harmonic measurements

The 8753ET and 8753ES RF network analyzers offer an unbeatable combination of speed, performance, and ease of use to meet your measurement needs, whether in the R&D laboratory or on the production floor. With an integrated test set covering to 3 or 6 GHz, up to 110 dB of dynamic range, and both frequency and power sweeps, the 8753ET and 8753ES give you a powerful solution for characterizing the linear and nonlinear behavior of active and passive networks, devices, components, and subsystems.

### Family Features

Selecting the transmission/reflection analyzers (ET model) or S-parameter analyzers (ES model) allows you to choose the optimum level of performance versus cost for your application. The network analyzers feature two independent measurement channels that can measure and display up to four parameters simultaneously. You can choose to display any combination of reflection and transmission parameters, with magnitude, phase, group-delay, Smith-chart, polar, SWR, or time-domain formats. Easy-to-use softkeys let you access measurement functions quickly, and you can view results in overlay or split-screen format on the crisp, LCD color display using up to four gratitudes. A VGA-compatible output has been added to drive larger external monitors for enhanced viewing.

Test sequencing allows rapid, repeated execution of complex measurements with a single keystroke. In test-sequence mode, you make a measurement once from the front panel, and the analyzer stores the keystrokes so that the measurement can be repeated without any additional programming. You can also use a test sequence to control external devices through the parallel or GPIB port.

For measurements of mixers, tuners, and other frequency-translating devices, the frequency-offset mode allows the network analyzer source to be tuned independently from the receiver. Measurements of conversion loss, phase, group-delay, and mixer-tracking can easily be done, with either fixed or swept-IF testing.<sup>1</sup>

Power-meter calibration provides leveled absolute power to devices that are sensitive to absolute input or output levels. The 8753ET/ES automatically controls an 436A, 437B, 438A, E4418B or E4419B power meter to set the power anywhere in the test setup with power-meter accuracy, or to calibrate the network analyzer receivers for accurate absolute-power measurements.

Other productivity features include a built-in floppy-disk drive supporting LIF, DOS, JPEG, and comma separated variable (CSV) formats, non-volatile memory, serial and parallel interfaces, a DIN keyboard interface, and a real-time clock for time-stamping of printouts and files. Limit testing, arbitrary frequency testing, and marker-tracking functions are included. You can reduce measurement time by using swept-list mode to choose specific frequencies to test, and to set independent IF bandwidths and power levels in each frequency range. Segmented calibration and interpolated error correction allow you to apply vector-accuracy enhancement over a subset of the analyzer's calibrated frequency range. The 8753ET/ES code compatibility with the 8753D/E enables you to leverage your existing software.

With Option 010, you can view reflection or transmission responses in the time domain. The analyzer computes the inverse FFT of the frequency-domain data to display the reflection or transmission coefficient versus time. Two time-domain analysis modes enable you to view the step or impulse response of your device. Time gating can be used to remove unwanted responses such as connector mismatch, and the gated results can be displayed in either the time or frequency domains.

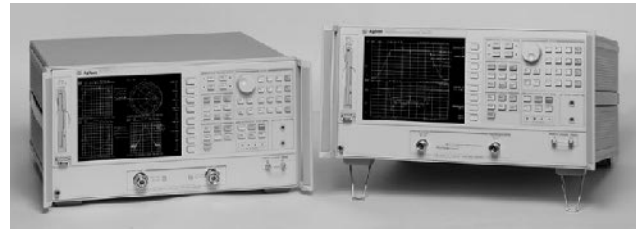

Powerful measurement solutions

Combine an S-parameter network analyzer with the time domain capability to provide a simple, deterministic method for tuning cavity-resonator bandpass filters. Comparing the filter's reflection response in time-domain with the response of a properly tuned filter reveals which resonators or coupling adjustments need to be tuned. With time-domain filter tuning, you can easily train new personnel for this complex task and greatly simplify fine-tuning and troubleshooting procedures.

For more advanced characterization of devices, Option 002 adds harmonic-measurement capability. Swept second and third-harmonic levels of an amplifier can be displayed absolutely or in dBc relative to the fundamental. With the press of a button, you can measure harmonics down to -40 dBc.

A high-stability frequency reference, Option 1D5, improves the frequency accuracy of measurements of high-Q devices such as SAW and crystal resonators or dielectric-resonance filters.

### ET Models

The 8753ET features a built-in 50-ohm transmission/reflection (T/R) test set providing a full range of magnitude and phase measurements. Frequency coverage is from 300 kHz to 3 or 6 GHz. The T/R capability provides a very high level of accuracy and convenience in making forward measurements of the device under test. Enhanced response calibration corrects for the effects of source match in a transmission measurement. Option 004 extends the standard -20 to +5 dBm source power range to -85 to +10 dBm.

### ES Models

The 8753ES features a built-in 50-ohm or 75-ohm S-parameter test set providing a full range of magnitude and phase measurements. Full two-port error correction capability provides the highest level of accuracy and the S-parameter test set provides the convenience of making both forward and reverse sweep measurements without reversing the device under test. For configuration flexibility, Option 011 deletes the built-in test set so that you can select your own. The 8753ES Option 011 works with the 85046A/B and 85047A S-parameter test sets, and other specialized test sets for specific applications. Option 014 provides a configurable test set for maximum flexibility. For convenient, accurate measurements in noncoaxial environments, TRL\*/LRM\*<sup>2</sup> calibration is available. Highly accurate measurements of non-insertable devices can also be achieved using the built-in adapter-removal calibration technique.

Agilent-qualified Channel Partners provide measurement hardware and software solutions that combine with Agilent's network analyzer products to offer a complete solution for your testing needs. For additional information, please refer to page 79.

<sup>1</sup>Phase measurements require reference mixer

<sup>2</sup>TRL\* and LRM\* are three-sampler implementations of the through-reflect-line and line-reflect-match calibration techniques.

8753ET  
8753ES

5

## Specifications Summary

### Test Sets

8753ET provides an integrated transmission/reflection test set with complete forward measurements in 50 ohm. 8753ES provides an integrated S-parameter test set with complete forward and reverse measurements in 50-ohm (standard) or 75-ohm (Option 075). External test sets supported with the 8753ES Option 011.

### Upgrade Kits for the 8753ET and 8753ES

Upgrade kits retrofit the latest operating system or add optional measurement capability to existing network analyzers. To order, add a “U” to the end of the model number of the instrument to be upgraded, and specify the desired option(s):

#### Option 002 Harmonic-Measurements Upgrade

This upgrade kit adds harmonic-measurement capability (Option 002) to an 8753ET or 8753ES network analyzer. This kit includes installation at an Agilent service center.

#### Option 004 Step Attenuator Upgrade

This upgrade kit adds a step attenuator to the 8753ET network analyzer. This enables the output power range to operate from -85 to +10 dBm instead of the standard -20 to +5 dBm. This kit includes installation at an Agilent Service Center.

#### Option 006 6 GHz Upgrade for Standard Units

This kit extends the operating frequency range of the standard 8753ET or 8753ES from 3 GHz to 6 GHz. Includes installation at an Agilent service center. Not compatible with 8753ES Option 075 or Option 011.

#### Option 611 6 GHz Upgrade for Option 011 Units

This kit extends the operating frequency range of the 8753ES Option 011 from 3 GHz to 6 GHz. Includes installation at an Agilent service center.

#### Option 010 Time-Domain Upgrade

This upgrade kit adds time-domain-analysis capability (Option 010) to an existing 8753ET or 8753ES network analyzer. This kit is user-installable.

#### Option 099 Firmware Upgrade Kit

This kit provides the latest version of firmware for the 8753ET or 8753ES network analyzer. The kit is user-installable. This kit may be optionally downloaded from Agilent’s web site: [www.agilent.com/find/firmware](http://www.agilent.com/find/firmware)

#### Option 1D5 High-Stability Frequency Reference Upgrade

This option adds a high-stability frequency reference (Option 1D5) to an 8753ET or 8753ES network analyzer. Includes installation at an Agilent service center.

### Key Literature

8753ET/ES Network Analyzer Brochure, p/n 5968-5159E  
 8753ET/ES Network Analyzer Technical Specifications, p/n 5968-5160E  
 8753ET/ES Network Analyzer Configuration Guide, p/n 5968-5158E

For more information, visit our web site: [www.agilent.com/find/8753](http://www.agilent.com/find/8753)

	8753ET	8753ES	8753ES Option 011
<b>Impedance</b>	50 ohm (standard)	50 ohm (standard) 75 ohm (Option 075)	Depends on test set
<b>Minimum frequency</b>	300 kHz	30 kHz	300 kHz (30 kHz with Option 006)
<b>Maximum frequency</b>	3 GHz (6 GHz with Option 006)	3 GHz (6 GHz with Option 006)	3 GHz (6 GHz with Option 006)
<b>Frequency resolution</b>	1 Hz	1 Hz	1 Hz
<b>Max. source power</b>	5 dBm (10 dBm with Option 004)	10 dBm (8 dBm with Option 075 or Option 014)	20 dBm (18 dBm between 3 to 6 GHz with Option 006)
<b>Min. source power</b>	-20 dBm (-85 dBm with Option 004)	-85 dBm	-5 dBm
<b>Power resolution</b>	0.01 dB	0.01 dB	0.01 dB
<b>Power flatness</b>	< ± 0.5 dB	± 1 dB	± 1 dB
<b>Power sweep range</b>	25 dB	25 dB	25 dB
<b>System dynamic range (&gt;300kHz)</b>	100 dB to 110 dB	100 dB to 110 dB	Depends on test set
<b>Test port connector</b>	Type-N (f)	7 mm (75 ohm Type-N (f) with Option 075)	Depends on test set

Data applies at 25° C ±5° C. See product literature for more complete specifications and for total measurement uncertainty after error correction.

**Size:** 222mm H x 425mm W x 457mm D (8.75in x 16.75in x 18in)

**Weight:** 21kg (46 lb) net; 35kg (77 lb) shipping



## External S-Parameter Test Sets

The S-parameter test sets provide the capability to measure reflection and transmission characteristics (including S-parameters) of two-port devices in either direction with a single connection. The test sets are controlled from the analyzer and include programmable step attenuators. These test sets are used with the 8753A/B/C or the 8753D/E/ES Option 011 only.

### 85046A/B S-Parameter Test Sets

The 85046A/B test sets provide the capability to simultaneously measure the transmission and reflection characteristics of 50-ohm and 75-ohm devices, respectively.

### Specifications Summary

	85046A	85046B
<b>Impedance</b>	50 $\Omega$	75 $\Omega$
<b>Frequency Range</b>	300 kHz to 3 GHz	300 kHz to 2 GHz
<b>Directivity</b>	35 dB to 1.3 GHz 30 dB to 3.0 GHz	35 dB to 1.3 GHz 30 dB to 2.0 GHz
<b>Typical Tracking Transmission Magnitude, Phase</b> <sup>1,2,3</sup>		
0.3 MHz to 2.0 MHz	$\pm 1.5$ dB, $\pm 20^\circ$	$\pm 1.5$ dB, $\pm 20^\circ$
2.0 MHz to Fmax	$\pm 1.5$ dB, $\pm 10^\circ$	$\pm 1.5$ dB, $\pm 10^\circ$
<b>Reflection Magnitude, Phase</b> <sup>1,2,3</sup>		
0.3 MHz to 2.0 MHz	$\pm 1.5$ dB, $\pm 25^\circ$	$\pm 1.5$ dB, $\pm 25^\circ$
2.0 MHz to Fmax	$\pm 1.5$ dB, $\pm 10^\circ$	$\pm 1.5$ dB, $\pm 10^\circ$
<b>Effective Source Match<sup>2</sup> (test ports)</b>		
0.3 MHz to 2.0 MHz	14 dB	14 dB
2.0 MHz to 1.3 GHz	20 dB	17 dB
2.0 MHz to Fmax	16 dB	16 dB
<b>RF Connectors</b>		
Test Ports	Precision 7 mm	75 $\Omega$ type-N (female)
All Others	50 $\Omega$ Type-N (female)	50 $\Omega$ Type-N (female)

<sup>1</sup>Degrees, specified as deviation from linear phase.

<sup>2</sup>Fmax is the upper frequency limit of the associated test set.

<sup>3</sup>Can be improved through accuracy enhancement.

**Includes:** Four 190-mm (7.5 in) cables with Type-N (male) connectors for connection to the 8753. One 8753 test set interconnect cable.

#### Physical Characteristics

**Size:** 90 mm H x 426 mm W x 508 mm D (3.5 in x 16.75 in x 20 in)

**Weight:** Net, 6.8 kg (15 lb); shipping, 9.1 kg (20 lb)

### 85047A S-Parameter Test Set

The 85047A test set includes a frequency doubler that can be switched in to measure 3 MHz to 6 GHz in a single sweep or switched out to measure 300 kHz to 3 GHz in a single sweep. The 8753B/C controls the frequency doubler. (The 8753D/E/ES Options 006 and 011 with built-in 6 GHz source does not use the frequency doubler, but are still compatible with the 85047A.) Option 006 (6 GHz receiver) is required to activate the 85047A.

### Specifications Summary

**Impedance:** 50  $\Omega$

**Frequency Ranges**

300 kHz to 3 GHz and 3 MHz to 6 GHz (8753B/C);

300 kHz to 6 GHz (8753D/E/ES Options 006 and 011)

**Directivity**

**300 kHz to 1.3 GHz:** 35 dB;

**1.3 GHz to 3 GHz:** 30 dB

**3 GHz to 6 GHz:** 25 dB

**Typical Tracking**

**Transmission Magnitude, Phase**

**300 kHz to 3 GHz:**  $\pm 1.5$  dB,  $\pm 10^\circ$ ;

**3 GHz to 6 GHz:**  $+0.5$ ,  $-2.5$  dB,  $\pm 20^\circ$

**Reflection Magnitude, Phase**

**00 kHz to 3 GHz:**  $\pm 1.5$  dB,  $\pm 10^\circ$ ;

**3 GHz to 6 GHz:**  $\pm 1.5$  dB,  $\pm 20^\circ$

**Effective Source Match**

**300 kHz to 1.3 GHz:** 20 dB;

**1.3 GHz to 3 GHz:** 16 dB

**3 GHz to 6 GHz:** 14 dB

**RF Connectors**

**Test Ports:** Precision 7 mm

**All Others:** 50  $\Omega$  Type-N (female)

**Includes:** Four 190 mm (7.5 in) cables with Type-N (male) connectors for connection to the 8753, one 8753 test set interconnect cable.

**Physical Characteristics**

**Size:** 90 mm H x 426 mm W x 508 mm D (3.5 in x 16.75 in x 20 in)

**Weight:** Net, 10 kg (22 lb); shipping, 15 kg (33 lb)

### External Test Set Switching

Option 009 replaces the standard solid-state RF test port switch with a mechanical RF switch. 8753 system specifications for standard and Option 009 test sets are identical. Nominal insertion loss of the solid-state switch is less than 2 dB (at 3 GHz) or 3 dB (at 6 GHz), relative to a mechanical switch.

### Special Test Sets

Special test sets are available to configure the 8753ES for specific applications. Some examples are listed below. Contact Agilent for details about these products or for information about additional special options for 8753 network analyzers.

#### Option H16 Low Noise Floor

Adds the ability to reverse the port 2 coupler to increase the forward dynamic range by about 13 dB.

#### Option H39 Three-Port Test Set

Adds a third test port and switching to provide all transmission and reflection measurements for three-port devices.

#### Option H68 Extended frequency range above 6 GHz

Allows characterization of components up to 6.8 GHz.

#### Option H85 High power test set

Adds access to signal paths to allow the addition of an external amplifier, high power attenuators or isolators for handling up to 20 Watts of power at the test ports. Standard solid-state transfer switch is replaced by mechanical switch and internal attenuators are added.

8753ET/ES  
85046A/B  
85047A

## Transit Cases

Agilent offers a complete line of sturdy transit cases in valise and tote styles. The cases protect your instrument from shock, vibration, moisture, impact, and contamination, providing a secure enclosure for shipping. Model 9211-2651 (standard) or model 9211-7522 (tote) fit the 8753ET/ES.

## Key Literature

8753ET/ES Network Analyzer Brochure, p/n 5968-5159E  
8753ET/ES Network Analyzer Technical Specifications, p/n 5968-5160E  
8753ET/ES Network Analyzer Configuration Guide, p/n 5968-5158E

For more information, visit our web site: [www.agilent.com/find/8753](http://www.agilent.com/find/8753)

## Ordering Information

Note: A complete system consists of a network analyzer, calibration kit, and cables. Calibration kits and cables can be found in the Accessories section beginning on pg. 299.

- 8753ET** Network Analyzer, 300 kHz to 3 GHz
  - Opt 002** Harmonic Measurement Capability
  - Opt 004** Built-in Step Attenuator
  - Opt 006** 6 GHz Frequency Extension
  - Opt 010** Time-Domain Capability
  - Opt 1D5** High-Stability Frequency Reference
- 8753ES** Network Analyzer, 30 kHz to 3 GHz
  - Opt 002** Harmonic Measurement Capability
  - Opt 006** 6 GHz Frequency Extension
  - Opt 010** Time-Domain Capability
  - Opt 011** Delete Built-in Test Set
  - Opt 014** Configurable Test Set
  - Opt 075** 75  $\Omega$  Impedance
  - Opt 1D5** High-Stability Frequency Reference
- 85047A** 50  $\Omega$  S-Parameter Test Set, 6 GHz
  - Opt 009** Mechanical Test Port Switch
  - Opt 913** Rackmount Kit (5062-4069)



- 85046A** 50  $\Omega$  S-Parameter Test Set, 3 GHz
  - Opt 009** Mechanical Test Port Switch
  - Opt 913** Rackmount Kit (5062-4069)
- 85046B** 75  $\Omega$  S-Parameter Test Set, 300 kHz, 2 GHz
  - Opt 009** Mechanical Test Port Switch
  - Opt 913** Rackmount Kit (5062-4069)



Options may be added to an 8753E family analyzer after initial purchase by ordering one of the following upgrade kits. To order an upgrade kit, specify the instrument's model number followed by a "U" to indicate upgrade, along with the option(s) you want to retrofit.

- 8753ET Upgrade Kits**
  - Opt 002** Harmonic Measurements Upgrade
  - Opt 004** Step Attenuator Upgrade
  - Opt 006** 6 GHz Upgrade for Standard Units
  - Opt 010** Time-Domain Upgrade
  - Opt 099** Firmware Upgrade Kit
  - Opt 1D5** High-Stability Frequency Reference Upgrade
- 8753ES Upgrade Kits**
  - Opt 002** Harmonic Measurements Upgrade
  - Opt 006** 6 GHz Upgrade for Standard Units
  - Opt 010** Time-Domain Upgrade
  - Opt 099** Firmware Upgrade Kit
  - Opt 1D5** High-Stability Frequency Reference Upgrade
  - Opt 611** 6 GHz Upgrade for Option 011 Units

## Transit Cases

- 9211-2651** Standard Transit Case
- 9211-7522** Tote-Style Transit Case

 Indicates QuickShip availability.

For more information on compatible printers, visit our web site: [www.agilent.com/find/pcg](http://www.agilent.com/find/pcg)

## 8720E Family Microwave Network Analyzers



- 50 MHz to 13.5, 20, or 40 GHz frequency coverage
- Choice of transmission/reflection or S-parameter test sets
- Fast measurement speeds and data-transfer rates
- Display up to four parameters at the same time
- Up to 105 dB dynamic range
- Optional time domain, frequency offset, and high power measurements



8720E Family of Network Analyzers

The 8720E family features six vector network analyzers to meet your measurement needs. The 8719ET, 8720ET, and 8722ET models offer economical transmission/reflection test sets, while the 8719ES, 8720ES, and 8722ES models offer S-parameter test sets and a wide selection of configurations for your applications. The ET models provide transmission and reflection measurements in the forward direction at an affordable price. The ES models provide both forward and reverse measurements and full two-port calibration for the best measurement accuracy.

Both ET and ES models combine a fast, synthesized source with an integrated test set covering frequencies from 50 MHz to 13.5, 20, or 40 GHz. Compact, economical, and easy to use, the 8720E family provides accurate and fast testing of microwave linear and nonlinear devices. These instruments are excellent tools for improving your designs in R&D or maximizing your measurement throughput in manufacturing.

### ET Models

The 8719ET, 8720ET, and 8722ET feature a built-in transmission/reflection test set for a full range of magnitude and phase measurements in the forward direction. Built-in vector accuracy enhancement techniques include one-port, response, and enhanced response calibrations. Enhanced response calibration improves the accuracy of transmission measurements by correcting for source match effects, which a regular response calibration cannot do. The optional 55-dB step attenuator provides a wider range of output power levels for testing active devices.

### ES Models

The 8719ES, 8720ES, and 8722ES feature solid-state switching S-parameter test sets with full two-port error correction. The ES models contain a 55-dB step attenuator as a standard feature for wide output power range. Enhanced response calibration provides improved accuracy for transmission measurements by correcting for source match without the speed penalty of a full two-port calibration. Adapter-removal calibration provides greater accuracy for measurements of non-insertable devices, such as devices with the same sex connectors on both ports or different connector types on ports 1 and 2. Electronic calibration (ECal) provides fast and simple calibration with a single connection, using the 85097A ECal PC Interface Kit, with the appropriate 85060 series calibration modules.

Agilent-qualified Channel Partners provide measurement hardware and software solutions that combine with Agilent's network analyzer products to offer a complete solution for your testing needs. For additional information, please refer to page 79.

## Affordable Analyzers with Outstanding Performance

The 8720 analyzers have a fast source that is fully synthesized, in either swept or stepped modes, with stability and accuracy within 10 ppm (typical). Frequency resolution is 1 Hz standard for accurate measurements of narrowband or long-delay devices. The tuned receivers with variable bandwidth IF filters provide up to 105 dB of dynamic range.

Two independent channels can measure and display up to four S-parameters simultaneously. Reflection and transmission measurements can be displayed in a variety of formats, including magnitude, phase, group delay, SWR, and Smith charts. The analyzer's display can be shown on a larger external monitor using the VGA-compatible display output.

Built-in vector accuracy enhancement provides excellent error-corrected accuracy in common coaxial connectors. A user kit supports user-defined standards, and allows calibration in waveguide (including effects of dispersion).

### Time Domain for Fault Location and Filter Tuning

Time domain capability (Option 010) computes and displays the response versus time or distance (instead of frequency) of the device under test. Use time domain to locate and quantify individual faults or mismatches in your device, fixture, or cable. Apply the gating feature to remove the effects of unwanted reflections (separated in time), then view the device's true response versus frequency.

Combine an S-parameter network analyzer with time domain capability to provide a simple, deterministic method for tuning cavity-resonator bandpass filters. Comparing the filter's reflection response in time-domain with the response of a properly tuned filter reveals which resonators or coupling adjustments need to be tuned. With time-domain filter tuning, you can easily train new personnel for this complex task and greatly simplify fine-tuning and troubleshooting procedures.

### Powerful Features for Active Devices

The 8720E family has plenty of power for testing amplifiers. Option 007 (ES models only) provides 5 dB more output power by replacing the solid-state transfer switch with a mechanical switch (although Option 007 does not provide continuous updating of all four S-parameters). For sensitive small-signal devices, the built-in step attenuator can reduce power to -65 or -70 dBm (Option 004 adds the step attenuator on ET models). Absolute power levels can be set accurately anywhere in the system, using the power meter calibration feature. Power-sweep capability and 0.01 dB power resolution make it easy to test the gain-compression characteristics of active components. The power level during retrace is controllable for safe testing of AGC amplifiers.

### In-Fixture and On-Wafer Device Characterization (ES models only)

Use TRL\*/LRM\* calibration to minimize fixture errors for measuring non-coaxial devices such as microstrip. For even better accuracy, Option 400 adds a fourth sampler and full TRL/LRM calibration. Electronic port extensions and gating are also available to enhance accuracy.

### Productivity Features

Swept-list mode reduces measurement time by allowing you to choose the frequencies you want to test, and to set independent IF bandwidths and power levels in each frequency range. Fast two-port tuning mode speeds up 12-term error correction by allowing the user to specify the number of forward sweeps to take before updating the reverse sweep.

Automate repeated measurements with test sequencing. Create test sequences with keystroke recording, then repeat the measurements with a single keystroke. No programming expertise is needed. You can also use test sequencing to control external devices such as part handlers through the parallel port.

Additional productivity features include limit testing for consistent pass/fail results, up to 5 markers per channel, serial and parallel interfaces for connecting to printers, 2 MB of internal non-volatile memory for storing up to 31 test configurations, JPEG, CSV (comma separated variable), and S2P-compatible data files for exchanging data with CAD programs such as EEsos's Touchstone, Libra, and Advanced Design System.

Programming code compatibility with the previous 8720D series of network analyzers allows you to protect and leverage your investment in test software.

8719ET  
8720ET  
8722ET  
8719ES  
8720ES  
8722ES

### Flexible Configuration for Applications

**Option 004** adds a 55-dB step attenuator to expand the output power range. (ET models only; step attenuator is included in all ES models)

**Option 007** replaces the standard solid-state transfer switch with a mechanical switch to provide 5 dB more power at the test port, and 5 dB more dynamic range. The mechanical transfer switch does not provide continuous updating of all four S-parameters for full two-port calibration. (ES models only)

**Option 010** adds time-domain capability, which allows fault location and gating of fixture responses. (ET and ES models)

**Option 012** provides direct sampler access, enabling the user to eliminate coupler loss and increase sensitivity by 16 dB. Option 012 allows filter rejection measurements to greater than -120 dB and allows insertion of attenuation between coupler and sampler. By using separate transmit and receive antennae, Option 012 can improve signal-to-noise in free-space measurements. (ES models only)

**Option 085** is a high-power S-parameter test set modification allowing device test up to +43 dBm (20 Watts) input and output. It deletes the bias tees, replaces the solid-state switch with a mechanical switch, and adds internal attenuators. It also includes the direct sampler access provided by Option 012. (ES models only)

**Option 089** offers a frequency offset mode for simple mixer conversion loss measurements without the need for a reference mixer. (ES models only)

**Option 1D5** adds a high-stability frequency reference to improve measurement accuracy of narrowband or high-Q devices. (ET and ES models)

**Option 400** adds a fourth sampler to the receiver and improves TRL calibration accuracy for in-fixture and on-wafer applications. Not compatible with Option 007 or 085. (ES models only)

### Upgrade Kits for the 8720E Family

Options may be added to an 8720E family analyzer after initial purchase by ordering the instrument's model number followed by a "U" to indicate an upgrade, along with the option(s) you want to retrofit. See "Ordering Information" for available upgrade options.

### Upgrading the 8720D Family

Customers with 8719D, 8720D, or 8722D analyzers can upgrade their analyzers to include the firmware features of the ES models with one of the following upgrades.

#### 8719DU, 8720DU, or 8722DU Option 099 Firmware Upgrade

Customers who have analyzers with firmware revision above 7.0 can order the latest firmware with this upgrade. The firmware can also be downloaded from Agilent's web site: [www.agilent.com/find/firmware](http://www.agilent.com/find/firmware)

#### 8719DU, 8720DU, or 8722DU Option 000 Performance Upgrade

Customers who have analyzers with firmware revisions below 7.0 can install the updated CPU board to provide significant measurement and data-transfer speed improvements and the latest firmware features.

### Key Literature

8720E Family Microwave Network Analyzers Brochure, p/n 5968-5161E

8720E Family Microwave Network Analyzers Technical Specifications, p/n 5968-5163E

8720E Family Microwave Network Analyzers Configuration Guide, p/n 5968-5162E

For more information, visit our web site: [www.agilent.com/find/8720](http://www.agilent.com/find/8720)

### Specifications Summary

	8719ET 8719ES	8720ET 8720ES	8722ET 8722ES
<b>Minimum Frequency</b>	50 MHz	50 MHz	50 MHz
<b>Maximum Frequency</b>	13.5 GHz	20 GHz	40 GHz
<b>Frequency Resolution</b>	1 Hz	1 Hz	1 Hz
<b>Frequency Accuracy</b>	10 ppm	10 ppm	10 ppm
<b>Max. Source Power:</b>			
ET models	+10 dBm	+10 dBm	0 dBm, < 20 GHz; -5 dBm, 20 to 40 GHz
ES models (std)	+5 dBm	+5 dBm	-5 dBm, < 20 GHz; -10 dBm, 20 to 40 GHz
ES models with Option 007	+10 dBm	+10 dBm	0 dBm, < 20 GHz; -5 dBm, 20 to 40 GHz
<b>Min. Source Power:</b>			
ET models (std)	-10 dBm	-10 dBm	-15 dBm
ET models with Option 004	-65 dBm	-65 dBm	-70 dBm
ES models (std)	-70 dBm	-70 dBm	-75 dBm
ES models with Option 007	-65 dBm	-65 dBm	-70 dBm
<b>Power Resolution</b>	0.01 dB	0.01 dB	0.01 dB
<b>Power Flatness</b>	± 2 dB	± 2 dB	± 3 dB
<b>Power Sweep Range</b>	20 dB	20 dB	15 dB to 20 GHz; 10 dB, 20-40 GHz
<b>System Dynamic Range (&gt;2 GHz)</b>			
ET	104 dB	104 dB	84 to 97 dB
ES	100 dB	100 dB	80 to 93 dB
ES with Option 007	105 dB	105 dB	85 to 98 dB
<b>Test Port Connector</b>	3.5 mm (m)	3.5 mm (m)	2.4 mm (m)

Data applies at 23° C ± 3° C. See product literature for more complete specifications and for total measurement uncertainty after error correction.

**Size:** 222 mm H x 425 mm W x 457 mm D (8.75 in x 16.750 in x 18.00 in)

**Weight:** Net, 22.7 to 27.7 kg (50 to 60 lb); shipping, 31.8 to 36.7 kg (70 to 81 lb)



### Ordering Information

Note: A complete system consists of a network analyzer, calibration kit, and cables. Calibration kits and cables can be found in the Accessories section beginning on page 299.

**8719ET** Network Analyzer, 50 MHz to 13.5 GHz

**8720ET** Network Analyzer, 50 MHz to 20 GHz

**8722ET** Network Analyzer, 50 MHz to 40 GHz

The following options apply to all three network analyzers:

**Opt 004** Step Attenuator

**Opt 010** Time Domain Capability

**Opt 1D5** High-Stability Frequency Reference

**Opt 1CM** Rackmount Kit

**Opt 1CP** Rackmount and Handle Kit

**8719ES** Network Analyzer, 50 MHz to 13.5 GHz

**8720ES** Network Analyzer, 50 MHz to 20 GHz

**8722ES** Network Analyzer, 50 MHz to 40 GHz

The following options apply to all three network analyzers:

**Opt 007** Mechanical Transfer Switch

**Opt 010** Time Domain Capability

**Opt 012** Direct Sampler Access

**Opt 085** High-Power Test Set

**Opt 089** Frequency Offset Mode

**Opt 1D5** High-Stability Frequency Reference

**Opt 400** Four-Sampler Test Set

**Opt 1CM** Rackmount Kit

**Opt 1CP** Rackmount and Handle Kit

### Upgrades and Retrofit Kits

To add options to an 8720E family analyzer after initial purchase, order the analyzer's model number followed by a "U" with one of the following upgrade options. All upgrade/retrofit kits include installation at an Agilent service center or the factory.

The following upgrade options are available for the 8719ET, 8720ET, and 8722ET.

**Opt 004** Add Step Attenuator

**Opt 010** Add Time Domain Capability

**Opt 1D5** Add High-Stability Frequency Reference

The following upgrade options are available for the 8719ES, 8720ES, and 8722ES.

**Opt 007** Add Mechanical Transfer Switch

**Opt 010** Add Time Domain Capability

**Opt 012** Add Direct Sampler Access

**Opt 085** Add High-Power Test Capability

**Opt 089** Add Frequency Offset Mode

**Opt 1D5** Add High-Stability Frequency Reference

**Opt 489** Add Frequency Offset for Opt 400 Analyzers

**Opt 589** Add Frequency Offset for Opt 085 Analyzers

**Opt 400** Add Four-Sampler Test Set

The following upgrades are only available for the specified models. For 8719ET only:

**Opt 020** Upgrades 8719ET to 8720ET

**Opt 040** Upgrades 8719ET to 8722ET

For 8720ET only:

**Opt 040** Upgrades 8720ET to 8722ET

For 8719ES only:

**Opt 020** Upgrades 8719ES to 8720ES

**Opt 040** Upgrades 8719ES to 8722ES

For 8720ES only:

**Opt 040** Upgrades 8720ES to 8722ES

The following kits offer upgrades for older 8720 family network analyzers. Installation is not included.

**8719DU, 8720DU, or 8722DU Opt 099** Firmware Upgrade

**8719DU, 8720DU, or 8722DU Opt 000** Performance Upgrade

### Transit Cases

Agilent offers a complete line of sturdy transit cases in valise and tote styles. The cases protect your instrument from shock, vibration, moisture, impact, and contamination, providing a secure enclosure for shipping. Model 9211-2651 (standard) or model 9211-7522 (tote) fit the 8719ET/ES, 8720ET/ES, and 8722ET/ES.

**9211-2651** Standard Case

**9211-7522** Tote-style Case

8719ET  
8720ET  
8722ET  
8719ES  
8720ES  
8722ES

- 8720D
- Opt K22
- Z5621A
- Opt H36
- 87050B
- Opt H37
- 8753ES
- Opt H85

- RF voltage and phase measurements
- 100 kHz to 1 GHz high-impedance probe inputs
- 300 kHz to 2 GHz 50 Ω inputs



## Let Agilent Design and Build You a Custom Test Set

If your application requires a special configuration, ask us about our special options, which offer nonstandard specifications.

### A Special Twenty-Two Port Test Set

#### Special 8720D option K22

The 8720D K22 is a multifunction box with four ports in the forward path and four ports in the reverse path. Two ports allow the user to connect the 8720D/ES directly to the 8720D K22 for a full 12 port matrix. The additional forward and reverse ports can be connected to additional test equipment for custom configurations.



### Duplexer Test Set Adapter

#### Special Z5621A option H36

This test set adapter provides three ports to allow direct testing of duplexers. The test set adapter contains a solid-state switch. The connectors are 50 ohm Type-N. The transmitter-to-antenna and receiver-to-antenna paths can be measured; the transmitter-to-receiver path cannot be measured.



### Duplexer Test Set

#### Special 87050B option H37

The 87050B option H37 is a duplexer test set designed for use with a standard 8753D/E/ES network analyzer. The duplexer test set uses solid-state switching for port connections. The test set has seven ports located on the front panel. Two of these ports are APC-7 and mate with port 1 and port 2 of the network analyzer. The other five ports, labeled ANT, TX1, TX2, RX1, and RX2 are 50 ohm Type-N connectors and connect to the device under test.

### High-Power Test Set

#### Special 8753ES option H85

The 8753ES option H85 provides a built in high power test set. High power measurements can be made up to 20 watts (+43dBm) each test port. Frequency range of H85 is 50 MHz to 3 GHz or 6 GHz, with standard option 006. Test port connectors are NMD 3.5mm male. Option H85 uses a mechanical transfer switch.

For more information, contact the Agilent Call Center in your region.

- 45 MHz to 110 GHz frequency range
- Real-time, error-corrected measurements
- 60 dB effective directivity and source match
- Up to 100 dB dynamic range
- 0.001 dB, 0.01 degree, 0.01 ns measurement resolution
- Time-domain analysis



85107B

### 8510 Series Microwave Network Analyzers



The 8510 Series Microwave Vector Network Analyzers provide a complete solution for characterizing the linear behavior of either active or passive coaxial networks over the 45 MHz to 110 GHz frequency range. A complete system consists of the 8510C network analyzer, an S-parameter test set, and a compatible RF source. The 8510E (45 MHz to 20 GHz) is an unracked system. The 8510SX (45 MHz to 26.5 GHz) and the 85107B (45 MHz to 50 GHz) systems are fully integrated in an 85043C system rack, tested, and verified at the factory prior to shipment. They come with a one year on-site warranty. For millimeter wave measurements the 8510XF (45 MHz to 110 GHz) and 85106D (Q, U, V, and W band) are available. For pulse measurements the 85108A (2 GHz to 20 GHz, specials 0.5 to 20 GHz, and 2 GHz to 50 GHz) are available.

#### 8510C Network Analyzer

At the heart of the system is the 8510C vector network analyzer. Measurement results can be displayed on a large color CRT on one of two independent, yet identical, channels. The channels may be displayed individually, or simultaneously, with results presented in either log/linear magnitude, phase, or group delay format on rectangular or polar coordinates. Direct measurement of impedance is possible with the Smith chart format.

#### Real-Time Error Correction

The 8510's built-in, high-speed computer provides the capability to characterize and effectively remove the impact of systematic errors through accuracy enhancement techniques. Effective directivity and source match can be improved to as much as 60 dB. The data processing speed of the system is such that a fully error-corrected, 401 point trace of data is updated in under one second. This virtual "real-time" display of error-corrected data means that you can easily adjust your test device while it's being measured, with the assurance that you are viewing the data at the highest possible accuracy.

#### Time-Domain Analysis

The 8510 (with Option 010) has the capability of displaying the time-domain response of a network, obtained by computing the Inverse Fourier Transform of the frequency-domain response. The time-domain response displays the reflection coefficient of the network versus time, which displays the magnitude and location of each individual discontinuity, or else the transmission coefficient versus time, which displays each individual transmission path.

#### Pulsed-RF Measurement Capability

For the measurement of pulsed-RF devices, the 8510C can be equipped with wideband IF detectors (Option 008). When configured with a compatible test set (85110A/L), the system can measure pulse widths as narrow as 1  $\mu$ s on devices with output power up to 20 W (CW) [50 W (CW) for the 85110L]. Measurement formats include magnitude and phase versus frequency or time (pulse profile).

#### Test Sets

The test set is the system component that determines the frequency range of the system and is the main contributor to system specifications. Depending on the test set used, up to 100 dB of dynamic range is available. The precision IF processing and detection system contributes as little as  $\pm 0.05$  dB and  $\pm 0.5$  degree measurement uncertainty at a level of 50 dB below the reference. Meaningful resolutions of 0.001 dB, 0.01 degree, and 0.01 ns are easily available. Refer to page 296 for more information.

#### RF Sources

The recommended system sources for the 8510C are the 83621B (20 GHz), 83631B (26.5 GHz), and 83651B (50 GHz). These sources provide 1 Hz frequency resolution, stepped CW, phase-locked narrowband sweeps, and fully-synthesized start frequencies for broadband ramp sweeps. Other models of the 8360 series synthesized sweeper, and the 8340 series synthesized sweeper, are also compatible with the 8510C.

### System Software

#### 85161B Measurement Automation Software

The 85161B measurement automation software leads the operator through the measurement sequence one step at a time, from system setup and calibration, to device measurement and hardcopy output. Complete measurement configurations can be saved to disk for later recall. Also, data printout formats can be customized by the operator.

The 85161B software is designed for use with a PC running Basic Rev 6.3 or higher under Windows (3.1/95/NT), or 9000 Series 200 or 300 computers and Basic Operating System 5.0 or later.

#### Key Literature

- 8510 Systems Solutions Brochure, p/n 5965-8837E
- 8510C Family Network Analyzer Technical Data, p/n 5091-8484E
- 8510C Family Network Analyzer Configuration Guide, p/n 5091-8967E
- 8360 B/L Series Synthesized Sweeper Technical Data, p/n 5964-6062E

#### Ordering Information

- 8510C** Microwave Vector Network Analyzer
- Opt 008** Pulsed-RF Measurement Capability
- Opt 010** Time-Domain Capability
- 85043C** System Rack Kit
- 85161B** Measurement Automation Software

## S-Parameter Test Sets

Several S-parameter test sets are available for the 8510C network analyzer for broadband coaxial measurements from 45 MHz to 50 GHz. The 8514B, 8515A, and 8517B test sets have an architecture that develops a separate reference channel for each incident port. RF switching is done with a built-in electronic switch. For active device measurements, the test sets include the ability to apply dc bias (external) to the test port center conductors. Also available are two 90 dB step attenuators (60 dB in the 8517B) which allow control of the port 1 and port 2 signal levels.

## Pulsed-RF Measurement Test Sets

The 85110A/L test sets are specially configured for operation in pulsed-RF measurement systems (85108). Four 90 dB step attenuators protect each input of the fundamentally-mixed down converter to allow measurement of test devices with output power of 20 watts CW or 50 watts CW (85110L). Special options are available to 50 GHz.

## Coaxial Test Set General Information

	8514B	8515A	8517B	85110A	85110L
<b>Frequency range (GHz)</b>	0.045 to 20	0.045 to 26.50	0.045 to 50	2 to 20 <sup>2</sup>	0.045 to 2
<b>Test ports (port 1 or 2)</b>					
Nominal operating power level (dBm)	2 to -6	-5 to -25	+2 to -29 +5 to -16 <sup>1</sup>	0 to -3	0
<b>Test ports (port 1 or 2)</b>					
Max. power in (CW)	+20 dBm	+2 dBm	+13 dBm	+43 dBm (20 W)	+47 dBm (50 W)
<b>Test port connector type</b>	3.5 mm (m)	3.5 mm (m)	2.4 mm (m)	3.5 mm (m)	7 mm

<sup>1</sup>8517B Option 007

<sup>2</sup>Special test sets options are available from 0.5 to 20 GHz and 2 to 50 GHz

## Frequency Converters

With the 8511A (26.5 GHz) and 8511B (50 GHz) frequency converters, the 8510 becomes a general-purpose, four-channel magnitude/phase receiver. Add your own power splitters for transmission measurements, and bridges or directional couplers for reflection measurements. Since one input is used for system phase-lock, the other three inputs are available for measurements of multi-port devices, subsystems, and antennas. All four inputs have precision 3.5 mm (8511A) or 2.4 mm (8511B) connectors.

## Multiple Test Set Operation

A single 8510C system may be configured with two test sets. In this configuration the test sets have different addresses, and the user may select between them from the front panel of the 8510 without reconnections. This capability is useful, for example, when combining a microwave coaxial test set with a millimeter-wave test set in the same 8510 system or; in manufacturing to increase throughput, one test set can be used to make a measurement while a device is being connected to a second test set.

IF switching (Option 001): In the multiple test set configuration, the 20 MHz IF signal is daisy-chained from the test sets to the 8510. This capability requires test set Option 001 in one of the two test sets.

The RF signal must be routed to the desired test set using a coaxial RF switch and an 11713A switch driver. The switch driver is controlled automatically by the 8510C over the 8510 system interface bus.

## Dedicated 8510 System Source Models

Dedicated sources are optimized for use as 8510 network analyzer system components. They are configured without modulation capabilities or front panel keyboard/displays, and with rear connectors, and with one-year, on-site service (where available). Specifications for these models are the 8510 specifications, plus the following:

### Frequency Range

83621B 45 MHz to 20 GHz  
83631B 45 MHz to 26.5 GHz  
83651B 45 MHz to 50 GHz

**Resolution:** 1 Hz

### Accuracy

**CW Mode:** Same as time base<sup>1</sup>

**Swept Mode** (at frequencies ≤ 26.5 GHz):

Sweep Widths ≤ n x 10 MHz: 0.1% of sweep width ± time base accuracy  
Sweep Widths > n x 10 MHz and ≤ 400 MHz: 1% of sweep width  
Sweep Widths > 400 MHz and ≤ 4 GHz: 4MHz  
Sweep Widths > 4 GHz: 0.1% of sweep width

**Swept Mode** (at frequencies > 26.5 GHz):

Sweep Widths ≤ n x 10 MHz: 0.1% of sweep width ± time base accuracy  
Sweep Widths > n x 10 MHz and ≤ 800 MHz: 1% of sweep width  
Sweep Widths > 800 MHz and ≤ 8 GHz: 8MHz  
Sweep Widths > 8 GHz: 0.1% of sweep width

### Output Power

#### Maximum Leveled

Frequencies ≤ 20 GHz: +10 dBm  
Frequencies > 20 GHz and ≤ 26.5 GHz: +4 dBm  
Frequencies > 26.5 GHz and ≤ 40 GHz: +3 dBm  
Frequencies > 40 GHz: 0 dBm

**Minimum Settable:** -20 dBm

<sup>1</sup>Internal time base verified to 1 ppm with standard on-site verification procedure.

## Key Literature

8510 Systems Solutions Brochure, p/n 5965-8837E  
8510C Family Network Analyzer Technical Data, p/n 5091-8484E  
8510C Family Network Analyzer Configuration Guide, p/n 5091-8967E

## Ordering Information

83621B 45 MHz to 20 GHz  
83631B 45 MHz to 26.5 GHz  
83651B 45 MHz to 50 GHz  
8511A Frequency Converter  
8511B Frequency Converter  
8514B S-Parameter Test Set  
8515A S-Parameter Test Set  
8517B S-Parameter Test Set  
85110A Pulsed-RF S-Parameter Test Set  
85110L Pulsed-RF S-Parameter Test Set  
85105A Millimeter-Wave Controller



### Millimeter-Wave Solutions

The 8510C system can easily be configured for making measurements at millimeter-wave frequencies. Agilent Technologies offers two fully integrated systems for making millimeter measurements in coax, waveguide, and on-wafer. The 8510XF is a single-connection, single-sweep, 45 MHz to 110 GHz network analyzer system. This system is designed for on-wafer and coaxial (1.0 mm) measurements. The 85106D offers hardware for configuring systems in the 33 to 50 GHz, 40 to 60 GHz, 50 to 75 GHz, and 75 to 110 GHz waveguide bands. These systems are fully integrated, tested, and verified at the factory prior to shipment. System installation at your facility and one year, on-site service are included at no additional cost.



8510XF configured with a wafer probing station and 1.0 mm probes

### 8510XF Single-Connection, Single-Sweep, .045 to 110 GHz Network Analyzer System

Covering a broadband frequency range in millimeter-wave has been virtually impossible due to the frequency limitations of each waveguide band. Agilent's recent development of a broadband connector, coaxial calibration kit, and directional couplers allows broadband devices to be measured over a wide frequency range, 45 MHz to 110 GHz, in one frequency sweep. All frequency band switching is performed internally by the 8510C, making it extremely convenient when measuring broadband devices on-wafer or in coax.

The 8510XF systems are equipped to measure broadband devices to 110 GHz in coax (1.0 mm) or on-wafer, fully calibrated, in a single sweep. The 8510XF provides excellent measurement performance in frequency coverage, dynamic range, and measurement accuracy.

### Broadband Calibration Improves Productivity

By performing a broadband calibration, from 45 MHz to 110 GHz, you are able to make measurements over the entire frequency range. Productivity is improved because you no longer need to connect and disconnect banded coaxial test sets or waveguide modules as your measurements move from one frequency band to the next.

### Convenient On-Wafer Calibration and Measurements with 1.0 mm Wafer Probes

The 8510XF system is convenient for on-wafer measurements. The test heads mount on the probe stations. A short, flexible 1.0 mm coaxial cable connects the test head to the wafer probe tip. Mounting the test heads on the probe station allows the test heads to move with the wafer probe tips. This configuration eliminates cable flexing and improves measurement performance.

Probing equipment and accessories are available from Cascade Microtech Inc., Beaverton, Oregon, USA.

### Millimeter-Wave Measurements Made in 1.0 mm Coax

With the 1.0 mm coaxial connectors and calibration kits, you can now make fully error-corrected measurements to 110 GHz. Measurements made in 1.0 mm coax deliver uncompromised performance with improved productivity, as compared to waveguide. The 1.0 mm connector is a sturdy, long life, precision connector that will provide repeatable connections. It has been accepted as a worldwide standard by the IEEE and IEC (the published standards are forthcoming).

There is no longer a need to struggle with waveguide; the measurement setup is configured with the test heads placed close to the device-under-test (DUT). You simply connect the short, flexible 1.0 mm coax cables between the test heads and your DUT. This configuration allows maximum flexibility while minimizing cable losses at 110 GHz.

### Upgrade Your Current 8510 System to Grow Your Measurement Capability

Your 8510-based system can be upgraded to an 8510XF to meet your new design and test challenges. Agilent offers pre-configured upgrades for your standard 85107B, 85106C/D and 85109C systems. Upgrades include hardware and firmware and are installed on-site. Customized upgrades are also available for other 8510 systems. Calibration kits and cables must be purchased separately.

### 85106D Millimeter-Wave Network Analyzer Subsystem

The 85106D millimeter-wave network analyzer subsystem includes an 8510C network analyzer, an 85105A millimeter-wave controller, an 83621B synthesized source as the RF, and an 83621B synthesized source as the LO, all mounted in a single bay rack with extendable work surface.

Two 85104A series test set modules are required to complete the system. With these configurations, both forward and reverse measurements can be made with a single connection to the device under test. The greatest convenience and highest accuracy is assured through the TRL (through-reflect-line) calibration technique. Precision calibration kits and verification kits are also available for these waveguide bands.

The 85106D can be configured as a combination microwave/millimeter-wave S-parameter system with Option 001. This option adds an 8517B microwave test set, 50 GHz source (83651B), 85133F test port return cable set, 85056A calibration kit, and appropriate cabling for convenient switching between millimeter-wave operation and microwave operation with no re-connections required.

### Key Literature

- 8510 System Solutions Brochure, p/n 5965-8837E
- 8510C Family Network Analyzer Technical Data, p/n 5091-8484E
- 8510C Family Network Analyzer Configuration Guide, p/n 5091-8967E
- 8510XF Family, Single-Sweep Systems Product Overview, p/n 5965-9888E
- 85106D Millimeter-wave Network Analyzer System Product Overview, p/n 5964-4229E

### Ordering Information

#### Complete 8510XF Systems

**E7340A** Single-connection, single-sweep network analyzer system (2 to 85 GHz)

**Opt 005** Extend low frequency to 45 MHz

**Opt 006** RF pass thru

**Opt 010** Add time domain capability to 8510C

**E7350A** Single-connection, single-sweep network analyzer system (2 to 110 GHz)

**Opt 005** Extend low frequency to 45 MHz

**Opt 006** RF pass thru

**Opt 010** Add time domain capability to 8510C

**85106D** Millimeter-Wave Network Analyzer Subsystem

**Opt 001** Add Microwave Test Set (8517B),

50 GHz Source (83651B), and 2.4 mm Accessories

**Opt 007** High Dynamic Range Configuration (to 50 GHz)

**Opt 010** Add Time-Domain Capability to 8510C

**V85104A** Test Set Module (50 GHz to 75 GHz)

**W85104A** Test Set Module (75 GHz to 110 GHz)

For more information, including custom configurations, contact the Agilent Call Center in your region.

8510XF  
E7340A  
E7350A  
85106D

**85108A/L Pulsed-RF Network Analyzer Systems****High Power Device Characterization**

The 8510C can be configured for convenient single-connection, multiple-measurements of high-volume, high-power and pulsed testing of IF, RF, and microwave frequency ranges. By pulsing the RF, the average power through the device is reduced, thereby reducing thermal effects on the device and making accurate characterization possible. These systems also include on-site installation, and a one-year, on-site warranty to ensure that the systems remain up and running.

**85108A Pulsed-RF Network Analyzer System**

The 85108A is a factory-integrated system that provides the entire instrument configuration required to make pulsed-RF measurements from 2 to 20 GHz. Special options are available to add frequency coverage to 50 GHz.

The system is built around the 8510C with the pulsed-RF measurement option (Option 008) already installed. The system also includes the 85110A S-parameter test set. 83622B and 83624B synthesized sweepers provide, respectively, the RF and LO signals needed to operate the fundamentally mixed test set.

**85108L Pulsed-RF Network Analyzer System**

The 85108L with the 85110L pulsed-RF test set provides improvements to pulsed-RF network analysis in many areas, but specifically extends the frequency coverage down to 45 MHz and up to 2 GHz. Special options are available to extend the upper frequency. The 85108L system is built around the same 8510C and includes two 83620B Option H80 synthesizers. The system is optimized for component testing in applications such as cellular, direct broadcast satellite, and VHF/UHF.

The 85110L has excellent pulsed-RF and CW performance with system dynamic range greater than 70 dB when using the wideband detectors and better than 95 dB when using the standard narrowband detectors. Both detectors are included in the 85108 systems.

**8510C Option 008**

The 8510C pulsed-RF measurement capability (Option 008) consists of an additional receiver subsystem for the 8510. This pulsed-RF measurement capability, which exists in parallel with the standard 8510C operation, provides you with the ability to measure and display the relative magnitude and phase shift of the component as a function of time with equivalent bandwidth of 1.5 MHz. This allows the evaluation of the dynamic pulsed-RF characteristics for pulse widths down to 1 microsecond. Using the repetitive sampling method, point-to-point display resolution of 100 ns is available.

**High Power CW or Pulsed-RF Measurements**

An 85110A or 85110L S-parameter test set is a required system component for the 8510C pulsed-RF measurement capability. The figure below shows a simplified block diagram of this test set.

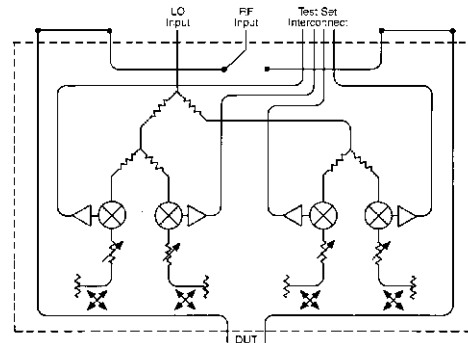

The block diagram provides some distinct advantages, whether using the 8510C for pulsed-RF or standard S-parameter measurements. Because of the coupler-based measurement path and attenuators, the test set can handle high powers, up to 20 W (85110A) or 50 W (85110L) CW.

Key to the pulse performance of the test sets are the fundamental mixers used to provide the low noise IF necessary to make accurate, pulsed-RF measurements with the pulsed-RF receiver subsystem. Two external synthesizers act as the RF and LO sources for the four-channel downconverter. This approach eliminates the need to dedicate one channel for phase-lock, making full two-port, pulsed-RF S-parameter measurements available. Also, the internal pulse modulator of the RF synthesizer can be used to pulse the device-under-test.

The connections available on the rear panel provide access to the measurement path, making it easy to configure test systems that use a single measurement connection for making multiple types of measurements such as spectrum analysis, noise figure, and load-pull. Special versions of the 85110A and 85110L test sets are available for even higher power applications or other frequency ranges.

**To Upgrade an Existing 8510C System for Pulsed-RF Measurements**

Your existing 8510 system can be upgraded to perform pulsed-RF measurements. This upgrade can be performed on-site or integrated into a full system at the factory.

**Key Literature**

8510 System Solutions Brochure, p/n 5965-8837E  
 8510C Family Network Analyzer Technical Data, p/n 5091-8484E  
 8510C Family Network Analyzer Configuration Guide, p/n 5091-8967E  
 85108 Series Network Analyzer Systems Data Sheet, p/n 5091-8965E  
 85106D Millimeter-Wave Network Analyzer System Product Overview, p/n 5964-4229E

**Ordering Information**

**85108A** Pulsed-RF Network Analyzer System  
**85108L** Pulsed-RF Network Analyzer System  
**Opt 010** Add Time-Domain Capability to 8510C  
 (applies to both 85108A and 85108L)

For more information, including custom configurations, contact the Agilent Call Center in your region.

## Calibration Kits

Error-correction procedures require that the systematic errors in the measurement system be characterized by measuring known devices (standards) on the system over the frequency range of interest. Agilent Technologies offers two types of calibration kits: mechanical and electronic. For further information about these products, please refer to the Agilent RF & Microwave Test Accessories Catalog, or visit the web site: [http://www.agilent.com/find/mta\\_catalog](http://www.agilent.com/find/mta_catalog)



## Mechanical Calibration Kits

All network analyzer, coaxial mechanical calibration kits contain standards to characterize systematic errors. Many mechanical calibration kits also contains adapters for test ports and a torque wrench for proper connection. Mechanical calibration kits are divided into three categories: economy, standard, and precision. Economy kits include a fixed load. Standard kits include a sliding load. Precision kits contain TRL devices.



## Electronic Calibration (ECal) Modules

NEW

Electronic calibration (ECal) is a precision, single-connection, one- or two-port calibration technique that uses fully traceable and verifiable electronic calibration modules. ECal provides repeatable, accurate measurements while bringing convenience and simplicity to your daily calibration routine. ECal replaces the traditional calibration technique, which uses mechanical standards. With mechanical standards, you are required to make numerous connections to the test ports for a single calibration. These traditional calibrations require intensive operator interaction, which is prone to errors.

ECal modules consist of a connector-specific calibration standard. Modules are available with 3.5mm, 7mm, Type-N, Type-F, and 7-16 connectors. The Type-N, Type-F, 7-16, and 3.5mm modules have one male and one female connector. Options exist for modules with two male or two female connectors. ECal modules are controlled via the 85097A PC interface kit and ECal software that runs on a Windows-based PC (not included). The PNA Series (E8356A, E8357A, and E8358A) of network analyzers can control RF ECal modules directly via a USB port, and does not require the 85097A kit.

## PC Interface Module with Control Software

The 85097A consists of a PC interface module, control software, and power supply. The interface module is the interface between the parallel port on your computer, the ECal module, and the external power supply. The control software has two interfaces: the graphical user interface (GUI) and the software programming interface (SPI). The GUI allows users to perform an electronic calibration in manual mode via the softkeys on your network analyzer. The SPI allows the calibration to be performed automatically by a user program. The software runs on a PC under Windows 95 or Windows NT 4.0 operating system or higher. The 85097A requires a PC with a GPIB (IEEE-488) interface card connected to the network analyzer. The 85097A interfaces with the 8510B (firmware revision 6.0 or higher), 8510C, 8719C/D/ET/ES, 8720C/D/ET/ES, 8722C/D/ET/ES, and 8753C/D/E/ET/ES.

## Mechanical Verification Kits

Measuring known devices, other than the calibration standards, is a straightforward way of verifying that the network analyzer system is operating properly. Agilent offers verification kits that include precision airlines, mismatch airlines, and precision fixed attenuators. Traceable measurement data, on disk, is shipped with each kit. Verification kits may be recertified by Agilent Technologies. This recertification includes a new measurement of all standards and new data with uncertainties.

### Coaxial Mechanical Calibration Kits

Legend: O = open S = short L = load SL = sliding load TRL = TRL adapter

Device connector type	Frequency upper limit <sup>1</sup>	Included	Available options	Model
Type-F (75 ohm)	3 GHz	O, S, L (m) and (f), adapters	00M, 00F	85039B
Type-N (75 ohm)	3 GHz	O, S, L (m)		85036E
Type-N (75 ohm)	3 GHz	O, S, L (m) and (f), adapters		85036B
Type-N (50 ohm)	6 GHz	O, S, L (m)		85032E
Type-N (50 ohm)	6 GHz	O, S, L (m) and (f), adapters	001	85032B
Type-N (50 ohm)	9 GHz	O, S, L (m) and (f)	07A, 0FA, 0MA, FMA	85032F
Type-N (50 ohm)	18 GHz	O, S, L, SL (m) and (f), adapters	002	85054B
Type-N (50 ohm)	18 GHz	O, S, L (m) and (f), adapters	002	85054D
7-16	7.5 GHz	O, S, L (m) and (f), adapters		85038A
7-16	7.5 GHz	O, S, L (f), adapters		85038F
7-16	7.5 GHz	O, S, L (m), adapter		85038M
7 mm	6 GHz	O, S, L		85031B
7 mm	18 GHz	O, S, L	002	85050D
7 mm	18 GHz	O, S, L, SL	002	85050B
7 mm	18 GHz	O, S, L, TRL	002	85050C
3.5 mm	6 GHz	O, S, L (m) and (f), adapters	001, 002	85033D
3.5 mm	9 GHz	O, S, L (m) and (f)	07A, 00A, 0FA, 0MA, FMA	85033E
3.5 mm	26.5 GHz	O, S, L (m) and (f), adapters	002	85052D
3.5 mm	26.5 GHz	O, S, L, SL (m) and (f), adapters	002	85052B
3.5 mm	26.5 GHz	O, S, L (m) and (f), TRL adapters	002	85052C
2.92 mm	50 GHz	O, S, L, SL (m) and (f), adapters	001*, 002	85056K
2.4 mm	50 GHz	O, S, L (m) and (f), adapters	002	85056D
2.4 mm	50 GHz	O, S, L, SL (m) and (f), adapters	002	85056A
1 mm	110 GHz	O, S, L (m) and (f), adapters		85059A

<sup>1</sup>All coaxial calibration kits are specified from DC to their upper frequency limit.

### Waveguide Mechanical Calibration Kits

Device connector type	Frequency range (GHz)	Type	Available options	Model
WR-90	8.2 to 12.4	Precision	002	X11644A
WR-62	12.4 to 18	Precision	002	P11644A
WR-42	18 to 26.5	Precision	002	K11644A
WR-28	26.5 to 40	Precision	002	R11644A
WR-22	33 to 50	Precision	002	Q11644A
WR-15	50 to 75	Precision	002	V11644A
WR-10	75 to 110	Precision	002	W11644A

### Electronic Calibration Modules (ECal)

Device connector type	Frequency range	Available options	Model
Type-F (75 ohm) <sup>1</sup>	30 kHz to 3 GHz	00A, 00F, 00M	85099B
Type-N (75 ohm) <sup>1</sup>	30 kHz to 3 GHz	00A, 00F, 00M	85096B
Type-N (50 ohm) <sup>1</sup>	30 kHz to 9 GHz	00A, 00F, 00M	85092B
Type-N (50 ohm)	1 GHz to 18 GHz	001***, 00A, 00F, 00M	85064B
7-16 <sup>1</sup>	30 kHz to 7.5 GHz	00A, 00F, 00M	85098B
7 mm <sup>1</sup>	30 kHz to 9 GHz		85091B
7 mm	1 GHz to 18 GHz	001***	85060B
3.5 mm <sup>1</sup>	30 kHz to 9 GHz	00A, 00F, 00M	85093B
3.5 mm	1 GHz to 26.5 GHz	001***, 00A, 00F, 00M	85062B
PC Interface kit <sup>2</sup>	N/A	N/A	85097A

<sup>1</sup>Modules have both USB and parallel connectors. A USB cable is supplied with the module.

<sup>2</sup>The PC Interface Unit is connected to a PC running Windows 95 or NT 4.0 (or higher) via a parallel cable. It is also connected to the ECal module(s) via another parallel cable. The PC Interface kit is not needed with the PNA Series (E8356A, E8357A, E8358A) network analyzers. These analyzers control the modules directly.

### Mechanical Verification Kits

Device connector type	Frequency range (GHz)	Type	Available options	Compatible network analyzers	Model	Price
Type-N	30 kHz to 18	Precision	002	8719, 8720, 8510, PNA	85055A	
7 mm	DC to 6	Precision	001**	8753	85029B	
7 mm	0.045 to 18	Precision	002	8719, 8720, 8510	85051B	
3.5 mm	30 kHz to 26.5	Precision	002	8719, 8720, 8510, PNA	85053B	
2.4 mm	0.045 to 50	Precision	002	8722, 8510	85057B	
WR-28	26.5 to 40	Precision	002	8510, 85106	R11645A	
WR-22	33 to 50	Precision	002	8510, 85106	Q11645A	
WR-15	50 to 75	Precision	002	8510, 85106	V11645A	
WR-10	75 to 110	Precision	002	8510, 85106	W11645A	

#### Options apply to mechanical calibration, ECal, and verification kits

**Opt 001** Deletes adapters

**Opt 001\***: Adds 2.4 mm sliding load and 2.4 mm gauges

**Opt 001\*\***: Adds data for 8702 lightweight component analyzer

**Opt 001\*\*\***: Adds 30 kHz to 9 GHz module

**Opt 002** Add calibration/verification data on magnetic tape in addition to 3.5" floppy

**Opt 00A** Adds four adapters, male-female 3.5 mm to male-female Type-N

**Opt 00M** Adds male standards and male-male adapter

**Opt 00F** Adds female standards and female-female adapter

**Opt 07A** Adds four device connector type to APC7 adapters

**Opt 0FA** Adds device connector type characterized female-female adapter

**Opt 0MA** Adds device connector type characterized male-male adapter

**Opt 0FMA** Adds device connector type characterized female-male adapter



### Cables

Test port cables provide the connection required when using network analyzers with various test devices and equipment. Test port cables are available for two test configurations as shown below. Configuration A utilizes a single test port cable for use when the device under test (DUT) is connected directly to the port on the test set. Configuration B utilizes two test port cables; which provides more flexibility since the DUT is connected between the test port cables.

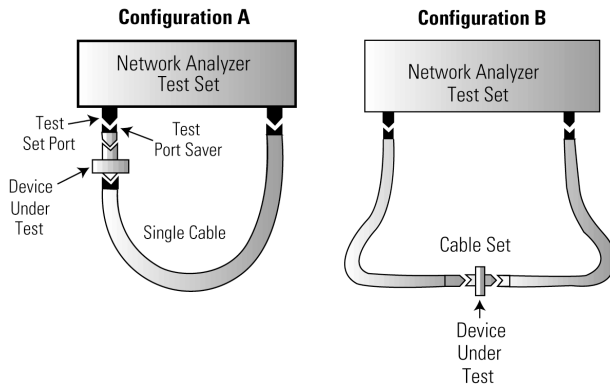

In order to select a cable, find the table below that corresponds to the connector type of your network analyzer. Then, search that table for your device's connector type. If the device's connector type is not present in the table, an adapter needs to be selected to mate the test port cable to your device. Adapters may be provided in a calibration kit, or ordered separately. A full detailed list of calibration kit contents is available from the Agilent RF & Microwave Test Accessories Catalog, which can be viewed from the web site: [www.agilent.com/find/mta\\_catalog](http://www.agilent.com/find/mta_catalog)

### 50-ohm, Type-N Test Set Ports

Device connector type	Cable connector description	Model
Type-N	Type-N (m) to Type-N (m), 24 in (61 cm)	<b>N6314A</b>
Type-N	Type-N (m) to Type-N (f)	<b>N6315A</b>
Type-N	Type-N (m) to Type-N (m), 16 in (40.6 cm)	<b>N3839A</b>
Type-N	Type-N (m) to Type-N (m), 24 in (610mm), qty 3 Type-N (m) to Type-N (m), 34 in (860 mm)	<b>11851B</b>

### 75-ohm, Type-N Test Set Ports

Device connector type	Cable connector description	Model
Type-N	75 ohm, Type-N (m) to Type-N (m) 75 ohm, Type-N (m) to Type-N (f)	<b>11857B</b>
Type-F	75 ohm, Type-N (m) to Type-F (m) 75 ohm, Type-N (m) to Type-F (f)	<b>11857F</b>

### 7-mm Test Set Ports

Device connector type	Cable connector description	Model
7 mm	7 mm to 7 mm, qty 2	<b>11857D</b>

### 3.5-mm Test Set Ports

Device connector type	Cable type	Cable connector description	Model
7 mm	Semi-rigid	3.5 mm (f) NMD to 7 mm 7 mm adapter set	<b>85132C</b> <b>85130B</b>
		3.5 mm (f) NMD to 7 mm 3.5 mm (f) NMD to 7 mm	<b>85132D</b>
7 mm	Flexible	3.5 mm (f) NMD to 7 mm 7 mm adapter set	<b>85132E</b> <b>85130B</b>
		3.5 mm (f) NMD to 7 mm 3.5 mm (f) NMD to 7 mm	<b>85132F</b>
3.5 mm	Semi-rigid	3.5 mm (f) NMD to 3.5 mm (f) 3.5 mm adapter set	<b>85131C</b> <b>85130D</b>
3.5 mm	Semi-rigid	3.5 mm (f) NMD to 3.5 mm (f) 3.5 mm (f) NMD to 3.5 mm (m)	<b>85131D</b>
3.5 mm	Flexible	3.5 mm (f) NMD to 3.5 mm (f) 3.5 mm adapter set	<b>85131E</b> <b>85130D</b>
		3.5 mm (f) NMD to 3.5 mm (f) 3.5 mm (f) NMD to 3.5 mm (m)	<b>85131F</b>
Type-N	NMD to 7mm	Use with 7 mm to Type N adapters Type N adapter set	<b>85130C</b>

NMD is a connector type designed to mate only with the 8510 and 8720 series network analyzer test ports.

### 2.4-mm Test Set Ports

Device connector type	Cable type	Cable connector description	Model
7 mm	Semi-rigid	2.4 mm (f) NMD to 7 mm 7 mm adapter set	<b>85135C</b> <b>85130E</b>
		2.4 mm (f) NMD to 7 mm 2.4 mm (f) NMD to 7 mm	<b>85135D</b>
7 mm	Flexible	2.4 mm (f) NMD to 7 mm 7 mm adapter set	<b>85135E</b> <b>85130E</b>
		2.4 mm (f) NMD to 7 mm 2.4 mm (f) NMD to 7 mm	<b>85135F</b>
3.5 mm	Semi-rigid	2.4 mm (f) NMD to 3.5 mm (f) 3.5 mm adapter set	<b>85134C</b> <b>85130F</b>
		2.4 mm (f) NMD to 3.5 mm (f) 2.4 mm (f) NMD to 3.5 mm (m)	<b>85134D</b>
3.5 mm	Flexible	2.4 mm (f) NMD to 3.5 mm (f) 3.5 mm adapter set	<b>85134E</b> <b>85130F</b>
		2.4 mm (f) NMD to 3.5 mm (f) 2.4 mm (f) NMD to 3.5 mm (m)	<b>85134F</b>
2.4 mm	Semi-rigid	2.4 mm (f) NMD to 2.4 mm (f) 2.4 mm adapter set	<b>85133C</b> <b>85130G</b>
		2.4 mm (f) NMD to 2.4 mm (f) 2.4 mm (f) NMD to 2.4 mm (m)	<b>85133D</b>
2.4 mm	Flexible	2.4 mm (f) NMD to 2.4 mm (f) 2.4 mm adapter set	<b>85133E</b> <b>85130G</b>
		2.4 mm (f) NMD to 2.4 mm (f) 2.4 mm (f) NMD to 2.4 mm (m)	<b>85133F</b>

NMD is a connector type designed to mate only with the 8510 and 8720 series network analyzer test ports.

### 1.0-mm Test Set Ports

Device connector type	Cable connector description	Model
1.0 mm	1.0 mm (f) to 1.0 mm (f)	<b>11500I</b>
1.0 mm	1.0 mm (f) to 1.0 mm (m), 16 cm	<b>11500J</b>
1.0 mm	1.0 mm (f) to 1.0 mm (m), 20 cm	<b>11500K</b>
1.0 mm	1.0 mm (f) to 1.0 mm (m), 24 cm	<b>11500L</b>

## Network Analyzer Accessories

### 11930A/B Power Limiters

The 11930A/B limiters protect the input circuits of network analyzers, spectrum analyzers, and sources from transients and short-duration overloads.

### 11850C/D Three Way Power Splitters

The 11850C/D 50 ohm, three-way power splitters are recommended for use with the 8753 (300 kHz to 3 GHz) network analyzers. The 11851B RF cable kit is suggested.

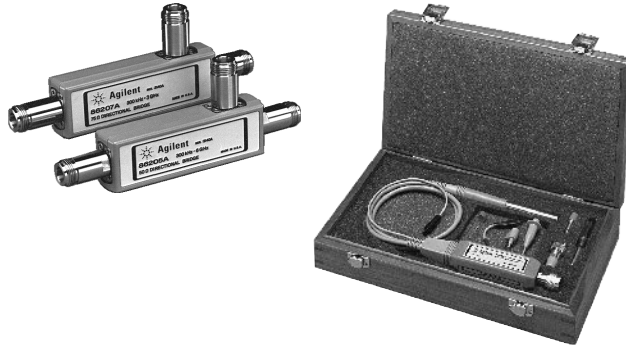

86205A/86207A

85024A

### 86205A/86207A RF Bridges

The 86205A/86207A high directivity RF bridges offer unparalleled performance in a variety of general-purpose applications. They are ideal for accurate reflection measurements and signal leveling applications.

### 85024A High-Frequency Probe

The 85024A high-frequency probe makes it easy to perform in-circuit measurements. An input capacitance of only 0.7 pF shunted by 1 MΩ of resistance permits high-frequency probing without adversely loading the circuit-under-test. Excellent frequency response and unity gain guarantee high accuracy in swept measurements with this probe. High probe sensitivity and low distortion levels allow measurements to be made while taking advantage of the full dynamic range of RF analyzers. RF network analyzers such as the 8753E1/ES, 8753E, 3577A, and 4195A are directly compatible. Additionally, the 8560, 8590E, and ESA series signal analyzers are also compatible. You can use the 1122A probe power supply or any dual ± 15 V, 130 mA supply.

### 11852B 50 ohm/ 75 ohm Minimum Loss Pad

The 11852B is a low SWR minimum loss pad used to transform 50-ohm port impedance to 75-ohm or 75-ohm to 50-ohm.

### Type-N Accessory Kits

Each kit contains a type-N (female) short, a type-N (male) short, two type-N (male) barrels, two type-N (female) barrels, and a storage case.

#### 11853A 50-ohm Type-N Accessory Kit

Accessory kit furnishes components for measurement of devices with 50-ohm type-N connectors.

#### 11855A 75-ohm Type-N Accessory Kit

Accessory kit furnishes components for measurement of devices with 75-ohm type-N connectors. This kit also contains a 75-ohm type-N (male) termination.

#### 11887A Type-N/3.5mm Adapter Kit

Adapter kit contains: 3.5(f) to Type-N (M), 3.5(m) to Type-N(m), 3.5(f) to Type-N(f), and 3.5(m) to Type-N(f).

### BNC Accessory Kits

The BNC accessory kit contains two type-N (male) to BNC (female) adapters, two type-N (male) to BNC (male) adapters, two type-N (female) to BNC (female) adapters, two type-N (female) to BNC (male) adapters, a BNC (male) short, and a storage case.

#### 11854A 50-ohm BNC Accessory Kit

Accessory kit furnishes components for measurement of devices with 50-ohm BNC connectors.

#### 11856A 75-ohm BNC Accessory Kit

Accessory kit furnishes components for measurement of devices with 75-ohm BNC connectors. This kit also contains a 75-ohm BNC (male) termination.

### 7-16 Adapter Kits

The 11906 family adapter kits.

#### 11906A 7-16 to 7-16 Adapter Kit

Adapter kit contains:	quantity
7-16 male to male adapter	1
7-16 female to female adapter	1
7-16 male to female adapter	2

#### 11906B 7-16 to 50-ohm type-N Adapter Kit

Adapter kit contains:	quantity
Type-N male to 7-16 male adapter	1
Type-N female to 7-16 female adapter	1
Type-N female to 7-16 male adapter	1
Type-N male to 7-16 female adapter	1

#### 11906C 7-16 to 7-mm Adapter Kit

Adapter kit contains:	quantity
7-mm to 7-16 male adapter	2
7-mm to 7-16 female adapter	2

#### 11906D 7-16 to 3.5-mm Adapter Kit

Adapter kit contains:	quantity
3.5-mm male to 7-16 male adapter	1
3.5-mm female to 7-16 female adapter	1
3.5-mm female to 7-16 male adapter	1
3.5-mm male to 7-16 female adapter	1

### For 8510XF Systems (1.0 mm test port connectors)

Adapters	Connector Type
11920A/B/C <sup>1</sup> adapters	1.0 mm series adapters
11921A/B/C/D <sup>1</sup> adapters	1.0 mm to 1.85 mm series adapters
11922A/B/C/D <sup>1</sup> adapters	1.0 mm to 2.4 mm series adapters
11923A adapters	1.0 mm (f) to circuit card launch
V281C/D <sup>2</sup> adapters	1.0 mm to V-band waveband guide
W281C/D <sup>2</sup> adapters	1.0 mm to W-band waveband guide

<sup>1</sup>Suffix 'A' denotes male-to-male, 'B' denotes female-to-female, 'C' denotes male-to-female and 'D' denotes female-to-male.

<sup>2</sup>Suffix 'C' denotes 1.0 mm female and 'D' denotes 1.0 mm male.

### Ordering Information

- 11930A/B Power Limiters
- 11850C/D Three-Way Power Splitters

- 86205A/86207A RF Bridges
- 85024A High-Frequency Probe
- 11852B 50-ohm/ 75-ohm Minimum Loss Pad

- Type-N Accessory Kits
  - 11853A 50-ohm Type-N Accessory Kit
  - 11855A 75-ohm Type-N Accessory Kit
  - 11887A Type-N/3.5mm Adapter Kit

- BNC Accessory Kits
  - 11854A 50-ohm BNC Accessory Kit
  - 11856A 75-ohm BNC Accessory Kit

- 7-16 Adapter Kits
  - 11906A 7-16 to 7-16 Adapter Kit
  - 11906B 7-16 to 50-ohm type-N Adapter Kit
  - 11906C 7-16 to 7-mm Adapter Kit
  - 11906D 7-16 to 3.5-mm Adapter Kit

- Peak, peak-to-average ratio and average power measurements
- Time-gated power measurements
- Fast measurement speed over the GPIB (up to 1,000 readings per second with the E4416A and E9320 power sensors)
- 5 MHz modulation bandwidth
- Operates with all E-series and 8480 series power sensors
- Large 4-line measurement display on high-resolution LCD
- RS-232/422 serial interfaces as standard
- Standard 3-year global warranty

## E4416A and E4417A Peak and Average Power Meters

### Comprehensive measurement capability for TDMA, CDMA, and W-CDMA signals

The E4416A and E4417A high-performance, single and dual-channel power meters and E932X peak and average power sensors, provide a low-cost, single-box solution for peak, peak-to-average ratio, average power and time-gated measurements, for the complex modulation formats used in today's and future wireless communications systems.

Time-gated measurements are performed using the meters comprehensive triggering features, such as an external TTL compatible trigger input. Up to 4 simultaneous time-gated measurements can be made. Individual start and duration times can be setup, allowing user's to measure the average, peak, or peak-to-average ratio. For example, on a GSM signal, this capability can be used to measure the average power over 5% to 95 % of the burst duration, as well as measuring the peak power and pulse droop.

### Fast measurement speed without compromising accuracy and repeatability

Faster test times improve manufacturing productivity and efficiency. Designed for both bench and automatic test equipment (ATE) operation, the EPM-P series power meters along with the E9320 sensors, provides a measurement speed, over the GPIB, of 1,000 corrected readings per second.

The meter's 20 Msamples/second continuous sampling rate provides the capability to accurately profile complex modulation formats of up to 5 MHz bandwidth.

### Easy to use

The LCD display is arranged into two windows, an upper and lower window, and provides user's with the ability to show either a large 1-line or up to a 4-line numeric measurement display, or an analog display, or show the trace display. To provide an intuitive user interface, the meter's hardkeys provide the most frequently used functions for making measurements on TDMA and CDMA signals, such as the TRIGGER function, while the softkey menus simplify configuring the meter for the user's particular measurement needs.

To reduce repeated setup sequences, the SAVE/RECALL menu allows you to save up to 10 instrument states.

### Low cost of ownership

The EPM-P series power meters come with a standard 3-year warranty, and are fully compatible with the 8480 and E-series power sensors, therefore protecting your investment. This also gives an additional choice for conventional average power measurements.

### Specifications

**Frequency Range:** 9 kHz to 110 GHz, sensor dependent

**Power Range:** -70 to +44 dBm, sensor dependent

**Single Sensor Dynamic Range:**

**8480 series sensors:** 50dB maximum

**E series CW power sensors:** 90dB

**E series E9300 Average power sensors:** 80dB maximum

**E series E9320 Peak and Average power sensors:**

85 dB maximum (CW mode)

75 dB maximum (peak mode)

**Display Units:**

**Absolute:** Watts or dBm; **Relative:** Percent or dB

**Display Resolution:** Selectable resolution of 1.0, 0.1, 0.01, 0.001 dB in logarithmic mode, or 1 to 4 significant digits in linear mode.

### Measurement Characteristics:

**Measurements:** Average Power, Peak Power, Peak-to-Average Ratio and measurements between two time offsets (time-gating)

**Averaging:** Averaging over 1 to 1024 readings

**Modulation Bandwidth:** 5MHz maximum (set by meter and is sensor dependent)

### Instrumentation Accuracy:

**Absolute:**

**Logarithmic:**  $\pm 0.02$  dB; **Linear:**  $\pm 0.5\%$

**Relative:**

**Logarithmic:**  $\pm 0.04$  dB; **Linear:**  $\pm 1.0\%$

**Time Base Accuracy:** 0.1%

**Trigger Sources:** Internal, External TTL, GPIB, RS232/422,

### Sampling Characteristics:

**Sampling Rate:** 20 MSamples/second continuous sampling

**Sampling Technique:** Synchronous repetitive sampling

**1mW Power Reference:** Refer to EPM Series Power Meters

### Key Literature

Product Overview, p/n 5980-1471E

Technical Specifications, p/n 5980-1469E

Configuration Guide, p/n 5965-6481E

Application Note 64-1, Fundamentals of RF and Microwave Power Measurements, p/n 5965-6630E

Application Note 64-4, Four Steps for Better Power Measurements, p/n 5965-8161E

Product Note, Choosing the Right Power Meter and Sensor, p/n 5968-7150E

### Ordering Information

**E4416A** Power Meter (peak and average, single-channel)

**E4417A** Power Meter (peak and average, dual-channel)

**Opt 002** Supplies rear-panel sensor input

(power reference calibrator is on the front panel)

**Opt 003** Supplies rear-panel sensor input

(power reference calibrator is on the rear panel)

**Opt 004** Deletes the E9288A sensor cable

**Opt 908** Supplies a one-instrument rackmount kit

**Opt 909** Supplies a two-instrument rackmount kit

**Opt A6J** Supplies ANSI Z540 Certificate of

Calibration with data

### Accessories

**34131A** Hard transit case

**34161A** Accessory pouch

**34141A** Yellow soft carry case

### Power Sensor Cables:

For operation with E9320 power sensors:

**E9288A** 1.5 meters (5ft)

**E9288B** 3 meters (10ft)

**E9288C** 10 meters (31ft)

Note: The E9288A-C sensor cables will also operate with 8480 and E-series power sensors.

For operation with 8480 series, E441x and E9300 power sensors only:

**11730A** 1.5 meters (5ft)

**11730B** 3 meters (10ft)

**11730C** 6.1 meters (20ft)

**11730D** 15.2 meters (50ft)

**11730E** 30.5 meters (100ft)

**11730F** 61 meters (200ft)



EPM-P Series Power Meters

E9321A  
E9322A  
E9323A  
E9325A  
E9326A  
E9327A

- Operates with the new EPM-P Series Power Meters (E4416A and E4417A)
- Provides peak and average power measurements
- Fast measurement speed over the GPIB (up to 1,000 readings per second)
- 300 kHz, 1.5 MHz and 5 MHz modulation bandwidths
- Wide dynamic range sensors
- Calibration factors stored in EEPROM



E9320 Family Peak and Average Power Sensors

### E9320 Family Peak and Average Power Sensors

The E9320 power sensors must be used with an E9288A, B or C sensor cable and only operate with the EPM-P series power meters (E4416A and E4417A). These sensors have two measurement paths, one for peak and time-gated measurements (a fast sampled path) and another for stable, low-level average power measurements.

#### High Performance Sensors

The E932X sensors have two frequency ranges, from 50 MHz to 6 GHz to cover most wireless communications applications, and a higher frequency range 50 MHz to 18 GHz. Each frequency range has a choice of 3 different modulation bandwidth sensors:

- 300 kHz for TDMA signals, for example GSM,
- 1.5 MHz for CDMA, and
- 5 MHz for W-CDMA.

Using just one sensor, user's can measure W-CDMA, CDMA and TDMA as each sensor provides a medium and low modulation bandwidth setting, selectable by the meter. So user's can select the modulation bandwidth required for their application, while maintaining the maximum dynamic range.

#### Sensor Choices for Your Applications

Two frequency ranges are available, 50 MHz to 6 GHz and 50 MHz to 18 GHz. Three modulation bandwidths are also available:

- 300 kHz for TDMA signals, for example GSM,
- 1.5 MHz for CDMA (IS-95A), and
- 5 MHz for wideband-CDMA.

Therefore you can select the modulation bandwidth you require for your application, while maintaining the maximum wide dynamic range.

#### Fast Measurement Speed

The E9320 power sensors provide fast measurement speed, over the GPIB, up to 1,000 readings per second, with the E4416A power meter.

#### Optimum Measurement Accuracy and Repeatability

To minimize the sensor and source mismatch, one of the main contributors to the overall measurement uncertainty, the E9320 sensors have a low SWR specification (1.15 for signals <+10 dBm, 50 MHz to 2 GHz). Comprehensive error correction is also provided as the calibration factors, linearity, and temperature compensation data are all stored within the E9320 sensor's EEPROM.

### Specifications

Sensor model	Max. meas. bandwidth	Frequency range	Power range	Max. power
E9321A	300 kHz	50 MHz to 6 GHz	-65 to +20 dBm (max.)	+23 dBm average
E9322A	1.5 MHz	50 MHz to 6 GHz	-60 to +20 dBm (max.)	+23 dBm average
E9323A	5 MHz	50 MHz to 6 GHz	-60 to +20 dBm (max.)	+23 dBm average
E9325A	300 kHz	50 MHz to 18 GHz	-65 to +20 dBm (max.)	+23 dBm average
E9326A	1.5 MHz	50 MHz to 18 GHz	-60 to +20 dBm (max.)	+23 dBm average
E9327A	5 MHz	50 MHz to 18 GHz	-60 to +20 dBm (max.)	+23 dBm average

### Key Literature

- Product Overview, p/n 5980-1471E
- Technical Specifications, p/n 5980-1469E
- Configuration Guide, p/n 5965-6481E
- Application Note 64-1, Fundamentals of RF and Microwave Power Measurements, p/n 5965-6630E
- Application Note 64-4, Four Steps for Better Power Measurements, p/n 5965-8161E
- Product Note, Choosing the Right Power Meter and Sensor, p/n 5968-7150E

### Ordering Information

- E9321A** Power Sensor, 50 MHz to 6 GHz, 300 kHz bandwidth  
Opt A6J Supplies ANSI Z540 Certificate of Calibration with data
- E9322A** Power Sensor, 50 MHz to 6 GHz, 1.5 MHz bandwidth  
Opt A6J Supplies ANSI Z540 Certificate of Calibration with data
- E9323A** Power Sensor, 50 MHz to 6 GHz, 5 MHz bandwidth  
Opt A6J Supplies ANSI Z540 Certificate of Calibration with data
- E9325A** Power Sensor, 50 MHz to 18 GHz, 300 kHz bandwidth  
Opt A6J Supplies ANSI Z540 Certificate of Calibration with data
- E9326A** Power Sensor, 50 MHz to 18 GHz, 1.5 MHz bandwidth  
Opt A6J Supplies ANSI Z540 Certificate of Calibration with data
- E9327A** Power Sensor, 50 MHz to 18 GHz, 5 MHz bandwidth  
Opt A6J Supplies ANSI Z540 Certificate of Calibration with data



- Fast measurement speed (up to 200 readings per second with the E4418B, and 100 readings per second with the E4419B, over the GPIB, with E-series sensors)
- Speed improvement of x2 using the 8480-series power sensor (compared to 437B)
- Code-compatible with the 436A and 437B (E4418B) and 438B (E4419B)
- Operates with the new E-series plus all 8480 series power sensors
- No range-switching delays with 8480-series sensors (over a 50 dB range), and only one fast-range switch point with E-series sensors (over a 90 dB range)
- High-resolution LCD display with backlighting for a wide viewing angle of data
- Same height and width as the 437B and the 438A
- Conformity to CE and CSA standards
- Standard 3-year global warranty
- RS-232/422 serial interfaces as standard
- Internal rechargeable battery option

### E4418B Single-Channel Power Meter

The E4418B is a low-cost, high-performance, single-channel, programmable power meter. It is fully compatible with the 8480 series of power sensors and the E-series of power sensors. Depending upon which sensor is used, the E4418B can measure from  $-70$  dBm to  $+44$  dBm at frequencies from 9 kHz to 110 GHz. Designed for bench and automatic test equipment (ATE) use, the E4418B makes fast (up to 200 readings per second with E-series sensors), accurate and repeatable power measurements.

The E4418B power meter has a high-resolution LCD display with LED backlighting and contrast control. This allows users to see the power readings from a distance, at a wide viewing angle and in a variety of lighting conditions. The user interface is easy to learn and use, with hardkeys for the most frequently used functions, and softkey menus to simplify instrument configuration for different applications. Ten instrument configurations can be saved and recalled, reducing the need to repeat setup sequences.

The E4418B is ideal for service and maintenance applications. The internal rechargeable battery option (option 001), which provides up to 5.5 hours of continuous operation, brings Agilent's accuracy to field applications. Front and rear panel bumpers protect the E4418B from everyday knocks. The meter weighs only 4 kg (9lbs), and a bail handle makes it easy to carry.

Because the E4418B power meter is designed to be code-compatible with the previous-generation 436A and 437B power meters, a user's investment in automatic-test procedures, software generation and verification is protected.

### E4419B Dual-Channel Power Meter

The E4419B is a low-cost, high-performance, dual-channel, programmable power meter. It is fully compatible with the 8480 series of power sensors and the new E series of power sensors. Depending upon which sensor is used, the E4419B can measure from  $-70$  dBm to  $+44$  dBm at frequencies from 9 kHz to 110 GHz.

Designed for bench and automatic test equipment use (ATE), the E4419B makes fast (up to 100 readings per second with E-series sensors), accurate and repeatable power measurements. The E4419B is a true dual-channel power meter, which means that you get two simultaneous power readings on the display.

The E4419B power meter has a high-resolution LCD display with LED backlighting and contrast control. This allows users to see the power readings from a distance, at a wide viewing angle and in a variety of lighting conditions. Users can display both the digital and analog types of readout on the meter's split screen facility. The analog peaking meter allows users to make accurate adjustments.

The user interface is easy to learn and use, with hardkeys for the most frequently used functions, and softkey menus to simplify instrument configuration for different applications. Difference (A-B, B-A) and ratio (A/B, B/A) functions are provided, and ten instrument configurations can be saved and recalled, reducing the need to repeat setup sequences.

Because the E4419B power meter is code compatible with the 438A and is the same height (88.5 mm / 3.5 in) and width (212.6 mm / 8.5 in) as the 438A, this makes it easy to substitute into rackmount automatic-test-equipment systems.



EPM Series Power Meters

### Specifications

**Frequency Range:** 9 kHz to 110 GHz, sensor dependent

**Power Range:**  $-70$  dBm to  $+44$  dBm (100 pW to 25 W), sensor dependent

**Power Sensors:** Compatible with all 8480 series and E-series sensors

**Single Sensor Dynamic Range**

90 dB maximum (E-series sensors)

50 dB maximum (8480 series sensors)

**Display Units**

**Absolute:** Watts or dBm

**Relative:** Percent or dB

**Display Resolution:** Selectable resolution of 1.0, 0.1, 0.01, and 0.001 dB in log mode, or 1 to 4 digits in linear mode

**Default Resolution:** 0.01 dB in log mode, 3 digits in linear mode

**Accuracy**

**Instrumentation**

**Absolute:**  $\pm 0.02$  dB (log) or  $\pm 0.5\%$  (linear). Add the corresponding power sensor linearity percentage

**Relative:**  $\pm 0.04$  dB (log) or  $\pm 1.0\%$  (linear). Add the corresponding power sensor linearity percentage

**Power Reference**

**Power Output:** 1.00 mW (0.0 dBm). Factory set to  $\pm 0.7\%$ , traceable to the U.S. National Institute of Standards and Technology (NIST)

**Accuracy:**  $\pm 1.2\%$  worst case ( $\pm 0.9\%$  rss) for one year

### Key Literature

Brochure, p/n 5965-6380E

Technical Specifications, p/n 5965-6382E

Configuration Guide, p/n 5965-6381E

Fundamentals of RF and Microwave Power Measurements

Application Note 64-1B, p/n 5965-6630E

### Ordering Information

**E4418B** Power Meter

**E4419B** Power Meter

**Opt 001** Supplies internal rechargeable battery

**Opt 002** Supplies rear-panel sensor input (power reference calibrator is on front panel)

**Opt 003** Supplies rear-panel sensor input (power reference calibrator is on rear panel)

**Opt 004** Deletes the 11730A sensor cable

**Opt 908** Supplies a one-instrument rackmount kit

**Opt 909** Supplies a two-instrument rackmount kit

**Opt A6J** Supplies ANSI Z540 Certificate of Calibration with data (E4418B/E4419B)

**Accessory**

**11683A** Range Calibrator

The 11683A range calibrator is specifically designed for use with the E4418A/B, E4419A/B, 435B, 436A, 437B, 438A, 70100A, and E1416A power meters. It allows verification of full-scale meter readings on all ranges, as well as meter tracking.

E4418B  
E4419B

5

8900C  
8900D  
70100A  
E1416A  
84811A



70100A



E1416A

### 70100A and E1416A MMS and VXI Power Meters

The 70100A is a full-featured single-channel power meter module for the modular measurement system. It has most of the capability of the 437B power meter in a one-eighth rack-width module. The 70100A features a similar feature set as the 437B, the same state-of-the-art accuracy, and is also fully compatible with the 8480 series of power sensors. The E1416A power meter is a VXI version of the 70100A.

#### 70100A, and E1416A Specifications

- Frequency Range:** 100 kHz to 110 GHz, sensor dependent
- Power Range:** -70 to +44 dBm (100 pW to 25 W), sensor dependent
- Power Sensors:** Compatible with all 8480 series power sensors
- Dynamic Range:** 50 dB in 10 dB steps
- Display Units:** Absolute: watts, dBm; relative: percent, dB
- Resolution:** Selectable resolution of 0.1, 0.01, and 0.001 dB in logarithmic mode; or 1% and 0.01% of full scale in linear mode

#### Accuracy

- Instrumentation:** ±0.02 dB or ±0.5%
- In REL Mode:** ±0.02 dB or ±0.5% within measurement range; ±0.04 dB or 1% outside measurement range
- Zero Set:** ±0.5% of full scale on most sensitive range

#### Power Reference

- Power Output:** 100 mW, factory-set to ±0.7%, traceable to US National Institute of Standards and Technology
- Accuracy:** ±1.2% worst case (±0.9% RSS) for 1 year

#### Key Literature

E1416A Technical Specifications, p/n 5965-5564E

#### Ordering Information

##### 70100A Power Meter Module

- Opt 003** Moves Reference Oscillator from Front to Rear Panel
- Opt 004** Deletes the 11730A Power Sensor Cable
- Opt 005** Deletes Reference Oscillator
- Opt W30** Extended Repair Service (see page 565)

##### E1416A Power Meter C-Size VXI

- Opt 004** Delete Sensor Cable
- Opt 915** Service Support Kit
- Opt 916** Additional User's Manual
- Opt W01** 3 Year Return-to-Agilent to 1 Year On-site Warranty
- Opt W32** 3 Year Customer Return Calibration Service
- Opt W34** 3 Year Customer Return Standards Compliant Calibration Service
- Opt W50** 5 Year Return Repair Service
- Opt W52** 5 Year Customer Return Calibration Service
- Opt W54** 5 Year Customer Return Standards Compliant Calibration Service



8900C



8900D

### 8900C/D Peak Power Meters

The 8900C and 8900D peak power meters directly display the peak power of RF pulses over a 100 MHz to 18 GHz frequency range. Measurements can be made on pulses with widths from 1 μs (100 ns in compare mode) to CW, and repetition rates from 100 Hz (0 Hz in compare mode) to 100 kHz.

The 8900C is an economical analog meter calibrated in watts and dBm. The analog display with its large, easy-to-read scale makes it simple to peak or null pulsed power systems. The 8900D has a high-resolution 3½-digit digital display calibrated in watts. The direct reading display and range annunciators make the digital version a good choice for production and field applications where unambiguous or frequent readings are required.

#### 84811A Peak Power Sensor

The 84811A peak power sensor works with the 8900C/D peak power meters to measure the peak power of RF pulses. It is supplied with a 4-foot flexible cable to easily reach the pulse source being measured. The 84811A also conveniently detaches from the meter for storage, recalibration, or replacement.

#### 8900C/D Peak Power Meters Specifications

- Frequency Range:** 100 MHz to 18 GHz
- Dynamic Range:** 20 dB (0 to +20 dBm)
- 8900C:** 4 ranges of 3, 10, 30, and 100 mW full scale
- 8900D:** 2 ranges of 10 and 100 mW full scale

#### Pulse Response:

##### Direct Mode

- Pulse Width: 1 μs to CW
- Repetition Rate: 100 Hz to 100 kHz

##### Compare Mode

- Pulse Width: 100 ns (typical) limited by rise-time specification
- Repetition Rate: 0 to 100 kHz

##### Rise Time: 75 ns

##### Fall Time: 125 ns (as measured on video output)

- Power Consumption:** 100 and 120 Vac +5, -10%, 48 to 66 Hz and 360 to 440 Hz; 220 and 240 Vac +5, -10%, 48 to 66 Hz

Meter accuracy	CW	Pulse	Transfer accuracy CW to pulse
Direct	±0.2 dB	±0.35 dB	±0.2 dB
Compare	±0.2 dB	±0.25 dB	±0.1 dB

#### 84811A Peak Power Sensor Specifications

- Power Range:** 0 to +20 dBm (1 mW to 100 mW)
- Frequency Range:** 100 MHz to 18 GHz
- SWR:** 100 MHz to 12 GHz <1.5, 12 GHz to 18 GHz <2.0
- Maximum Peak Power:** +24 dBm (250 mW) for 5 minutes
- Connector Type:** Type-N (male)
- Calibration Accuracy:** (+10° to +40° C), ±0.7 dB 0.1 to 12 GHz, ±1.0 dB to 18 GHz, 0° to 10° C and 40° to 55° C: add ±0.2 dB

#### Ordering Information

**8900C** Analog Peak Power Meter

**8900D** Digital Peak Power Meter

**Opt W30** Extended Repair Service (for 8900C/D)

**Opt W32** Calibration Service

**84811A** Peak Power Sensor

**Opt W30** Extended Repair Service

**Opt W32** Calibration Service



432A

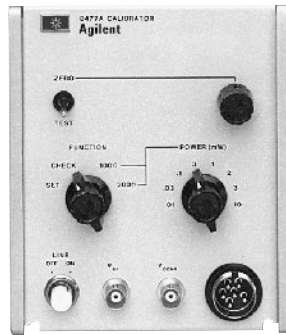

8477A



Thermistor Mounts

432A  
8477A  
478A  
8478B  
486A Series

### 432A Power Meter

- High accuracy—no thermoelectric error: High accuracy over a wide temperature range is featured on the 432A power meter. By measuring the output voltage of the thermistor bridges and computing the corresponding power, even higher accuracy of  $\pm 0.2$  percent  $\pm 0.5$   $\mu$ W can be obtained. Accuracy can be maintained on even the most sensitive range because the error due to thermoelectric effect is reduced to a negligible level.
- Calibrated mounts: Each thermistor mount is furnished with data stating the calibration factor and effective efficiency at various frequencies across the operating range. For easy and accurate power measurements, the front panel of the 432A has a calibration-factor control, calibrated in one-percent steps from 88 percent to 100 percent, that compensates for losses in the mount and eliminates the need for calculation.
- Instrument type: Automatic, self-balancing power meter for use with temperature-compensated thermistor sensor.

### Specifications (Partial)

**Power Range:** 7 ranges with full-scale readings of 10, 30, 100, and 300  $\mu$ W, 1, 3, and 10 mW; also calibrated in dBm from  $-20$  dBm to  $+10$  dBm full scale in 5 dB steps

**Noise:** Less than 0.25% of full scale peak (typical)

**Response Time:** At recorder output, 35 ms time constant (typical)

**Fine Zero:** Automatic, operated by front-panel switch

**Zero Carryover:** Less than 0.50% of full scale when zeroed on most sensitive range

**Meter:** Taut-band suspension, individually calibrated, mirror-backed scales. Milliwatt scale more than 108 mm (4.25 in) long

**Calibration Factor Control:** 13-position switch normalizes meter reading to account for thermistor sensor calibration factor. Range 100% to 88% in 1% steps.

**Thermistor Sensor:** Thermistor sensors are required for operation of the 432A. For microwave sensors 478A, 8478B, and 486 series, see next column.

**Recorder Output:** Proportional to indicated power with 1 volt corresponding to full scale. 1 k $\Omega$  output impedance.

**BCD Output:** 8, 4, 2, 1 code; "1" positive. TTL compatible logic. Operates with 5150A, Option 002 (BCD) digital recorder.

**Power Consumption:** 115 or 230 Vac  $\pm 10\%$ , 50 to 400 Hz, 1.5 watts

**Size:** 155 mm H x 130 mm W x 279 mm D (6.1 in x 5.2 in x 11.0 in)

**Weight:** Net, 2.3 kg (5.5 lb); shipping, 4.6 kg (10 lb)

### 8477A Power Meter Calibrator

The 8477A power meter calibrator is specifically designed for use with the 432A power meter. It allows you to verify full-scale meter readings on all ranges, and meter tracking. Simply connect three cables between the power meter and calibrator; no charts or additional instruments are required.

**Power:** 115 or 230 Vac  $\pm 10\%$ , 50 to 400 Hz, 3 watts

### Temperature-Compensated Thermistor Mounts

High efficiency and good radio frequency (RF) match are characteristic of the 478A and 8478B coaxial and 486A series waveguide thermistor mounts. Used in conjunction with the 432A power meter, they provide high accuracy even in routine power measurements. These thermistor mounts are temperature compensated for low drift, even in the presence of thermal shocks, permitting measurement of microwave power as low as one microwatt. Each mount contains data showing calibration factor and effective efficiency at six frequencies, directly traceable to the U.S. National Institute Standards and Technology at those frequencies where NIST provides calibration service.

### 486A, 478A, 8478B Specifications

Model	Frequency range, GHz	Maximum SWR
478A	10 MHz to 10 GHz	1.75, 10 to 25 MHz 1.3, 25 MHz to 7 GHz 1.5, 7 to 10 GHz
8478B <sup>1</sup>	10 MHz to 18 GHz	1.75, 10 to 30 MHz 1.35, 30 to 100 MHz 1.1, 0.1 to 1 GHz 1.35, 1 to 12.4 GHz 1.6, 12.4 to 18 GHz
X486A	8.20 to 12.4	1.5
P486A	12.4 to 18.0	1.5
K486A	18.0 to 26.5	2.0
R486A	26.5 to 40.0	2.0

<sup>1</sup>Option 011: Furnished with APC-7 RF connector +

### Ordering Information

#### 432A Power Meter

**Opt 001** Rechargeable battery installed, provides up to 20 hours of continuous operation (432A only)

**Opt 002** Input connector placed on rear panel in parallel with front

**Opt 003** Input connector on rear panel only

**Opt 009** 3.1 m (10 ft) Cable for 100  $\Omega$  or 200  $\Omega$  Sensor

**Opt 010** 6.1 m (20 ft) Cable for 100  $\Omega$  or 200  $\Omega$  Sensor

**Opt 011** 15.2 m (50 ft) Cable for 100  $\Omega$  or 200  $\Omega$  Sensor

**Opt 012** 30.5 m (100 ft) Cable for 100  $\Omega$  or 200  $\Omega$  Sensor

**Opt 013** 61 m (200 ft) Cable for 100  $\Omega$  or 200  $\Omega$  Sensor

**Opt 100** 100 Vac Operation, 48 to 66 Hz

**Opt 910** Extra Operating and Service Manual (432A: p/n 00432-90009)

**Opt W30** Extended Repair Service

**Opt W32** Calibration Service

#### 8477A Power Meter Calibrator

**Opt W30** Extended Repair Service

**Opt W32** Calibration Service

Indicates QuickShip availability.



E4412A  
E4413A  
E9300A  
E9300B  
E9300H  
E9301A  
E9301B  
E9301H  
E9304A

- Operates with the E4418A/B, E4419A/B, E4416A and E4417A power meters
- Wide dynamic range, -70 to +44 dBm, sensor dependent
- Frequency range, 9 kHz to 26.5 GHz, sensor dependent
- Fast measurement speed (up to 200 readings per second, over the GPIB, with the E4418A/B power meter)
- Calibration factors, linearity and temperature compensation data stored in EEPROM

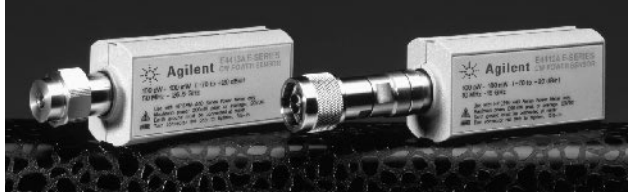

Examples of E-Series Power Sensors

### E-Series Power Sensors (E4412A, E4413A and E9300 range)

The E-series diode power sensors are wide dynamic range (90 dB maximum) which operate with the EPM and EPM-P series of power meters.

The E4412A and E4413A sensors are designed for providing power measurements on continuous wave (CW) signals over the range -70 to +20 dBm, whereas the E9300 family of power sensors measure the average power of RF and microwave signals, regardless of modulation format, over an 80 dB maximum range.

### 8480 Power Sensor Family

The 8480 power sensors are designed for use with the E4418A/B, E4419A/B, 435B, 436A, 437B, 438A, 70100A and E1416A power meters. These thermocouple and diode power sensors provide extraordinary accuracy, stability, and SWR over a wide range of frequencies (100 kHz to 110 GHz) and power levels (-70 to +44 dBm).

### E Series Specifications

Model/Frequency Range	Power Range	Maximum Power	Connector Type
<b>E4412A</b> 10 MHz to 18 GHz	100 pW to 100 mW (-70 to +20 dBm)	200 mW (+23 dBm)	Type-N (m)
<b>E4413A</b> 50 MHz to 26.5 GHz	100 pW to 100 mW (-70 to +20 dBm)	200 mW (+23 dBm)	APC-3.5mm (m)
<b>E9300A</b> 10 MHz to 18 GHz	1 nW to 100 mW (-60 to +20 dBm)	320 mW (+25 dBm) avg. 2W (+33 dBm) peak (<10 µsec)	Type-N (m)
<b>E9301A</b> 10 MHz to 6 GHz	1 nW to 100 mW (-60 to +20 dBm)	320 mW (+25 dBm) avg. 2W (+33 dBm) peak (<10 µsec)	Type-N (m)
<b>E9304A</b> 9 kHz to 6 GHz	1 nW to 100 mW (-60 to +20 dBm)	320 mW (+25 dBm) avg. 2W (+33 dBm) peak (<10 µsec)	Type-N (m)
<b>E9300B</b> 10 MHz to 18 GHz	1 µW to 25 W (-30 to +44 dBm)	0 °C to 35 °C: 30 W avg. 35 °C to 55 °C: 20 W avg. <6 GHz: 500 W peak >6 GHz: 125 W peak 500 Wµs per pulse	Type-N (m)
<b>E9301B</b> 10 MHz to 6 GHz	1 µW to 25 W (-30 to +44 dBm)	0 °C to 35 °C: 30 W avg. 35 °C to 55 °C: 20 W avg. <6 GHz: 500 W peak 500 Wµs per pulse	Type-N (m)
<b>E9300H</b> 10 MHz to 18 GHz	10 nW to 1 W (-50 to +30 dBm)	3.16 W avg. 100 W peak 100 Wµs per pulse	Type-N (m)
<b>E9301H</b> 10 MHz to 6 GHz	10 nW to 1 W (-50 to +30 dBm)	3.16 W avg. 100 W peakg. 100 Wµs per pulse	Type-N (m)

### Best SWR in the Industry

Mismatch uncertainty is usually the largest single source of error in power measurements. The 8480 power sensor family gives you extremely low SWR even at mm-wave frequencies. For example, the W8486A power sensor has a specified SWR of less than 1.08:1 over its entire 75 to 110 GHz frequency range. This low SWR translates into minimum mismatch uncertainty and optimum measurement accuracy.

### Accurate Calibration and Traceability

Each power sensor in the 8480 family is individually calibrated and traceable to the U.S. National Institute of Standards and Technology (NIST, formerly NBS). The uncertainty in this calibration factor is your link to NIST. The cal factor measurement system used by Standards Lab provides you with minimum cal factor uncertainty.

### Millimeter-Wave Sensor Calibration

A 50 MHz calibration port is included in Agilent waveguide power sensors for calibration with the power meter. This calibration provides traceability to NIST at millimeter-wave frequencies, and it eliminates the uncertainties due to temperature changes and the variance in making measurements with different meter/sensor combinations.

### Key Literature











- EPM Power Meter Brochure, p/n 5965-6380E
- E9300 Sensors Product Overview, p/n 5968-4960E
- Technical Specifications, p/n 5965-6382E
- Configuration Guide, p/n 5965-6381E
- Application Note 64-1B, p/n 5965-6630E
- Application Note 64-4B, p/n 5965-8167E

### Ordering Information

- E4412A** CW Power Sensor (10 MHz to 18 GHz)
- E4413A** CW Power Sensor (50 MHz to 26.5 GHz)
- E9300A** Average Power Sensor (10 MHz to 18 GHz)
- E9301A** Average Power Sensor (10 MHz to 6 GHz)
- E9304A** Average Power Sensor (9 kHz to 6 GHz)
- E9300B** Average Power Sensor (10 MHz to 18 GHz)
- E9301B** Average Power Sensor (10 MHz to 6 GHz)
- E9300H** Average Power Sensor (10 MHz to 18 GHz)
- E9301H** Average Power Sensor (10 MHz to 6 GHz)



### 8480 Series Specifications

Model	Frequency range	Maximum SWR	Power linearity <sup>1</sup>	Maximum power	Connector type	Weight	
<b>25 Watt Sensors 1 mW to 25 W (0 to +44 dBm)</b>							
<b>8481B</b>	10 MHz to 18 GHz	10 MHz to 2 GHz: 1.10 2 to 12.4 GHz: 1.18 12.4 to 18 GHz: 1.28	+35 to +44 dBm; ±4%	0° to 35° C: 30 W avg <sup>2</sup> 35° to 55° C: 25 W avg 0.01 to 5.8 GHz: 500 W pk 5.8 to 18 GHz: 125 W pk 500 W-µs per pulse	Type-N(m)	Net 0.8 kg (1.75 lb) Shipping 1.5 kg (3.25 lb)	
<b>8482B</b>	100 kHz to 4.2 GHz	100 kHz to 2 GHz: 1.10 2 to 4.2 GHz: 1.18			Type-N(m)		
<b>3 Watt Sensors 100 µW to 3 W (-10 to +35 dBm)</b>							
<b>8481H</b>	10 MHz to 18 GHz	10 MHz to 8 GHz: 1.20 8 to 12.4 GHz: 1.25 12.4 to 18 GHz: 1.30	+25 to +35 dBm; ±5%	3.5 W avg, 100 W pk 100 W-µs per pulse	Type-N(m)	Net 0.2 kg (0.38 lb) Shipping 0.5 kg (1 lb)	
<b>8482H</b>	100 kHz to 4.2 GHz	100 kHz to 4.2 GHz: 1.20			Type-N(m)		
<b>100 mW Sensors 1 µW to 100 mW (-30 to +20 dBm)</b>							
<b>8485A</b>	50 MHz to 26.5 GHz	50 to 100 MHz: 1.15 100 MHz to 2 GHz: 1.10 2 to 2.4 GHz: 1.15 12.4 to 18 GHz: 1.20 18 to 26.5 GHz: 1.25	+10 to +20 dBm; +2, -4%	300 m W avg, 15 W pk 30 W-µs per pulse	APC-3.5 mm (m)	Net 0.2 kg (0.38 lb) Shipping 0.5 kg (1 lb)	
<b>Option 033</b>	50 MHz to 33 GHz	26.5 to 33 GHz: 1.40					
<b>8481A</b>	10 MHz to 18 GHz	10 to 30 MHz: 1.40 30 to 50 MHz: 1.18 50 MHz to 2 GHz: 1.10 2 to 12.4 GHz: 1.18 12.4 to 18 GHz: 1.28			Type-N(m)		
<b>8482A</b>	100 kHz to 4.2 GHz	100 to 300 kHz: 1.60 0.3 to 1 MHz: 1.20 1 MHz to 2 GHz: 1.10 2 to 4.2 GHz: 1.30			Type-N(m)		
<b>8483A</b> (75 Ω)	100 kHz to 2 GHz	100 to 600 kHz: 1.80 600 kHz to 2 GHz: 1.18		300 mW avg, 10 W pk	Type-N(m) 75 Ω		
<b>R8486A</b>	26.5 to 40 GHz	1.4	+10 to +20 dBm; +2, -4%	300 mW avg, 15 W pk 30 W-µs per pulse	Waveguide Flange UG-599/U	Net 0.26 kg (0.53 lb) Shipping 0.66 kg (1.3 lb)	
<b>Q8486A</b>	33 to 50 GHz	1.5			Waveguide Flange UG-383/U		
<b>V8486A</b>	50 to 75 GHz	1.04	+10 to +20 dBm; ±2% -30 to +10 dBm <±1%	200mV avg 40 W pk 10 us pulse 0.5% duty cycle	Waveguide Flange UG-385/U	Net 0.4 kg (0.91 lb) Shipping 1 kg (2.11 lb)	
<b>W8486A</b>	75 to 110 GHz	1.08	+1, -3%	200 mW avg 40 W peak	Waveguide Flange UG-387/U	Net 0.4 kg (0.9 lb) Shipping 1.0 kg (2.1 lb)	
<b>8487A</b>	50 MHz to 50 GHz	50 to 100 MHz: 1.15 100 MHz to 2 GHz: 1.10 2 to 12.4 GHz: 1.15 12.4 to 18 GHz: 1.20 18 to 26.5 GHz: 1.25 26.5 to 40 GHz: 1.30 40 to 50 GHz: 1.50	+10 to +20 dBm; +2, -4%	300 mW avg, 15 W pk 30 W-µs per pulse	2.4 mm (m)	Net 0.14 kg (0.28 lb) Shipping 0.5 kg (1 lb)	
<b>High Sensitivity Sensors 100 pW to 10 µW (-70 to -20 dBm)</b>							
<b>8481D<sup>3,4</sup></b>	10 MHz to 18 GHz	10 to 30 MHz: 1.40 30 MHz to 4 GHz: 1.15 4 to 10 GHz: 1.20 10 to 15 GHz: 1.30 15 to 18 GHz: 1.35	-30 to -20 dBm; ±1%	100 mW avg 100 mW pk	Type-N(m)	Net 0.18 kg (0.41 lb) Shipping 0.9 kg (2 lb)	
<b>8485D<sup>3</sup></b>	50 MHz to 26.5 GHz	0.05 to 0.1 GHz: 1.19 0.1 to 4 GHz: 1.15 4 to 12 GHz: 1.19 12 to 18 GHz: 1.25 18 to 26.5 GHz: 1.29	-30 to -20 dBm; ±2%	100 mW avg 100 mW pk	APC-3.5 mm (m)	Net 0.2 kg (0.38 lb) Shipping 0.5 kg (1 lb)	
<b>Option 033</b>	50 MHz to 33 GHz	26.5 to 33 GHz: 1.35					
<b>8487D<sup>3</sup></b>	50 MHz to 50 GHz	0.05 to 0.1 GHz: 1.19 0.1 to 2 GHz: 1.15 2 to 12.4 GHz: 1.20 12.4 to 18 GHz: 1.29 18 to 34 GHz: 1.37 34 to 40 GHz: 1.61 40 to 50 GHz: 1.89	-30 to -20 dBm; ±2%	100 mW avg 100 mW pk	2.4 mm (m)	Shipping 0.5 kg (1 lb) Net 0.2 kg (0.38 lb)	
<b>R8486D<sup>3</sup></b>	26.5 to 40 GHz	1.4	-30 to -25 dBm; ±3%	100 mW avg or pk 40 Vdc max	Waveguide Flange UG-599/U	Net 0.26 kg (0.53 lb) Shipping 0.66 kg (1.3 lb)	
<b>Q8486D<sup>3</sup></b>	33 to 50 GHz	1.4	-25 to -20 dBm; ±5%		Waveguide Flange UG-383/U		

<sup>1</sup>Negligible deviation except for those power ranges noted.

<sup>2</sup>For pulses greater than 30 W the maximum average power (P<sub>avg</sub>) is limited by the energy per pulse (E) in W-µs according to P<sub>avg</sub>=30/0.02E.

<sup>3</sup>Includes 11708A 30 dB attenuator for calibrating against a 0 dBm, 50 MHz power reference. 11708A is factory set to 30 dB ±0.05 dB at 50 MHz, traceable to NIST. SWR <1.05 at 50 MHz.

<sup>4</sup>This sensor directly replaces the popular 8484A power sensor.

# Noise Figure Analyzers

310

## 10 MHz to 1.5 GHz and 10 MHz to 3 GHz Noise Figure Analyzers

NFA Series  
N8972A  
N8973A

- A flexible and intuitive user interface
- Easy measurement setup
- Low instrument uncertainty
- Color graphical display of noise figure and gain versus frequency
- Enhanced PC and printer connectivity
- Agilent 346 and 347 noise source compatible
- Ability to load and save ENR data for noise sources via floppy disk
- Local oscillator control through second dedicated GPIB
- 3-year warranty as standard



N8973A

### NFA Series

#### A Flexible and Intuitive User Interface

The user interface on the new NFA series of Noise Figure Analyzers is intuitive and easy to use, with easy to find keys, which are sized and then placed in the relevant keygroup according to function. The soft-key depths have been kept to a minimum and there are clear visual indicators on the screen showing the current machine state.

#### Easy Measurement Setup

The NFA series of Noise Figure Analyzers now takes the pain out of complex measurement setups, with their simple but instructive menus. The built-in help button gives key function and remote programming commands, that should eliminate the need to carry manuals when setting up measurements.

#### Low Instrumentation Uncertainty

When making noise figure measurements, a key parameter to be aware of is measurement uncertainty. The NFA has a low instrumentation uncertainty to aid in accurate and repeatable measurement of manufacturers' components. In addition, to aid customers in setting their components/systems specifications, Agilent has produced a web-based uncertainty calculator that will give customers information on how to improve and classify their measurement specifications more accurately.

For more information, visit our web site at: [www.agilent.com/find/nf](http://www.agilent.com/find/nf)

#### Increase Measurement Throughput

In manufacturing environments, fast measurement speed and repeatability are critical. The NFA series of Noise Figure Analyzers now include many features that can reduce your measurement time and increase throughput. The frequency list function allows you to select specific points within a complete measurement span to make your measurement. The Sweep averaging function allows a real-time update to the screen during a measurement, as you adjust the performance of the DUT during a sweep. Both these functions, as well as the limit line functionality for quick and easy pass/fail testing and the additional ability to recall complete calibrated instrument states, increase productivity and measurement throughput.

#### Enhanced Connectivity

The built-in floppy disk drive, GPIB, RS232 serial and Printer port connectors allow quick and easy data transfer between the analyzer and a PC or workstation. There is also a built-in VGA connector for connecting a large-screen monitor.

#### Color Graphical Display

To enhance useability, the new Noise Figure Analyzers now come with an integrated 17cm full color LCD display, for simultaneous viewing of noise figure and gain against frequency. There are three different formats for viewing measurements, the two separate channel or combined graph format, a table format, and a spot frequency noise figure and gain measurement "meter" format.

#### Ease of Automation

The NFA series of Noise Figure Analyzers include 2 industry-standard GPIB ports and an RS232 serial port, to aid in the automated control of the instrument. The second GPIB port is dedicated to Local oscillator control. The default control language is SCPI, but users can also define custom LO commands.

#### Ease of Integration

To aid with the integration of the new analyzer into manufacturing environments, Agilent has produced a Programmers Reference Manual containing example programs to help migrate to the new system. The NFA is not code compatible with the 8970B, nor can it control the 8971C.

#### Full Measurement Capability

Features present in both the N8972A and N8973A

- Floppy disk loading and saving of ENR data
- Enhanced analysis through Limit lines and Marker functions
- Enhanced PC and printer connectivity and VGA output
- Internal data storage capable of storing up to 30 different state, trace, and setup files (dependent upon measurement complexity).
- 4MHz measurement bandwidth
- Frequency list mode, which enables the user to avoid known, polluted frequencies during a measurement or, used tactically to speed up a measurement.

#### Features only available on the N8973A

- Lower noise figure measurement uncertainty  $\pm 0.05$  dB
- Six user selectable bandwidths (100KHz, 200KHz, 400KHz, 1MHz, 2MHz, and 4MHz)
- Enhanced speed

### NFA Series Key Specifications

Specifications apply over 0° C to +55° C unless otherwise noted. The analyzer will meet its specifications after 2 hours of storage within the operating temperature range, 60 minutes after the analyzer is turned on, with Alignment running. A user calibration is required before corrected measurements can be made.

#### Frequency range

##### NFA Series:

**N8972A** 10 MHz to 1.5 GHz

**N8973A** 10 MHz to 3 GHz

#### Measurement speed (nominal)

##### 8 averages

**N8972A:** <100 ms/measurement

**N8973A:** <50 ms/measurement

##### 64 averages

<80 ms/measurement

<42 ms/measurement

#### Measurement bandwidth (nominal)

**N8972A:** 4MHz

**N8973A:** 4 MHz, 2 MHz, 1MHz, 400 kHz, 200 kHz, 100 kHz

#### Noise Figure and Gain

(Performance is dependent upon ENR of noise source used)

	Noise source ENR		
	4.5–6.5 dB	14–16 dB	20–22 dB
<b>N8972A</b>			

Noise Figure	Noise source ENR		
	4.5–6.5 dB	14–16 dB	20–22 dB
Measurement range	0 to 20dB	0 to 30dB	0 to 35dB
Instrument uncertainty	± < 0.1 dB	± < 0.1 dB	± < 0.15 dB

Gain	Noise source ENR		
	4.5–6.5 dB	14–16 dB	20–22 dB
Measurement range	-20 to +40 dB		
Instrument uncertainty	± < 0.29 dB		

	Noise source ENR		
	4.5–6.5 dB	14–16 dB	20–22 dB
<b>N8973A</b>			

Noise Figure	Noise source ENR		
	4.5–6.5 dB	14–16 dB	20–22 dB
Measurement range	0 to 20dB	0 to 30dB	0 to 35dB
Instrument uncertainty	± < 0.05dB	± < 0.05dB	± < 0.15dB

Gain	Noise source ENR		
	4.5–6.5 dB	14–16 dB	20–22 dB
Measurement range	-20 to +40 dB		
Instrument uncertainty	± < 0.29 dB		

#### Performance over limited temperature range of +23° C ± 3° C

Gain	
Instrument uncertainty	< ±0.2 dB

#### Characteristic Noise figure at 23° C ± 3° C

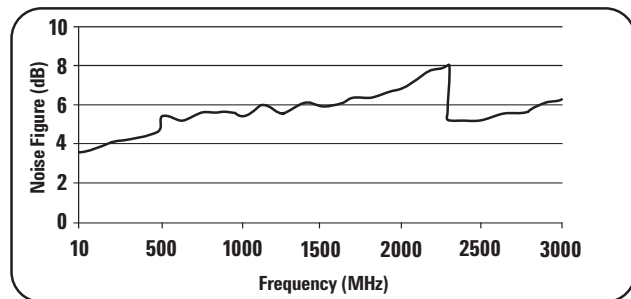

Characteristic values are met or bettered by 90% of instruments with 90% confidence.

#### Frequency reference

	Standard	Opt.1D5
Aging	± < 2x10 <sup>-6</sup> /year	± < 1x10 <sup>-7</sup> /year
Temperature stability	± < 6x10 <sup>-6</sup>	± < 1x10 <sup>-8</sup>
Settability	± < 5x10 <sup>-7</sup>	± < 1x10 <sup>-8</sup>

#### Tuning accuracy (Start, Stop, Center, Marker)

4MHz Measurement bandwidth ±< Reference error +100 kHz  
 <4MHz Measurement bandwidth ±< Reference error +20 kHz

### General Specifications

#### Dimensions

Without handle: 222 mm H x 375 mm W x 410 mm D (8.88 in x 15 in x 16.4 in)

With handle (max): 222 mm H x 409 mm W x 515 mm D (8.88 in x 16.36 in x 20.6 in)

#### Weight (typical, without options)

**N8972A:** 15.3 kg (33.7 lb)

**N8973A:** 15.5 kg (34.2 lb)

#### Data storage (nominal)

Internal drive: 30 traces, states or ENR tables

Floppy disk: 30 traces, states or ENR tables

#### Power requirements

On (line 1): 90 to 132 V rms, 47 to 440 Hz 195 to 250 V rms, 47 to 66 Hz

Power consumption: <300 W

Standby (line 0): <5 W

#### Temperature range

Operating: 0° C to +55° C

Storage: -40° C to +70° C

#### Humidity range

Operating: Up to 95% relative humidity to 40° C (non-condensing)

Altitude range: Operating to 4,600 meters

#### Calibration interval

1-year minimum recommended

#### Electromagnetic compatibility

Complies with the requirements of the EMC directive 89/336/EEC. This includes Generic Immunity Standard EN 50082-1:1992 and Radiated Interference Standard CISPR 11:1990/EN 55011:1991, Group 1 Class A. The conducted and radiated emissions performance typically meets CISPR 11:1990/EN 55011:1991 Group 1 Class B limits.

#### Warranty

3-Year warranty as standard

### Key Literature

Noise Figure Analyzers, NFA Series, Brochure, p/n 5980-0166E

Noise Figure Analyzers, NFA Series, Technical Specifications, p/n 5980-0164E

Noise Figure Analyzers, NFA Series, Configuration Guide, p/n 5980-0163E

Fundamentals of RF and Microwave Noise Figure Measurements, App note 57-1, p/n 5952-8255E

Noise Figure Measurement Accuracy, App note 57-2, p/n 5952-3706

10 Hints for Making Successful Noise Figure Measurements, p/n 5980-0228E

N8972A and N8973A, NFA Series, Noise Figure Analyzer Programming Examples, p/n 5968-9498E

### Ordering Information

**N8972A** Noise Figure Analyzer

**N8973A** Noise Figure Analyzer

**Opt A6J** (N8972A) Calibration to ANSI Z540-1 and ISO Standard

**Opt A6J** (N8973A) Calibration to ANSI Z540-1 and ISO Standard

**Opt 1CP** Rack Mount and Handle Kit

**Opt 1D5** High Stability Frequency Reference

**Opt UK9** Front Panel Cover

**Opt 0B0** DELETE Quick Reference Guide and CD Manuals

**Opt 0B1** Additional Quick Reference Guide and CD Manuals

**Opt 0B2** Hard Copy Users Guide(English)

**Opt 0BF** Hard Copy Programmers Reference Manual (English)

**Opt W32** 3 Year Calibration Service

**Opt W34** 3 Year Standards Compliant Calibration Service

**Opt W50** 5 Year Return Repair Service

**Opt W52** 5 Year Calibration Service

**Opt W54** 5 Year Standards Compliant Calibration Service

The manual set provided with the NFA, shall be in PDF format on CD, except for the quick reference guide, which will be in hard copy.

346A  
346B  
346C  
R347B  
Q347B



346A/B/C Broadband Noise Sources

## 346A/B/C Broadband Noise Sources

The ideal companion to the Agilent Noise Figure Analyzer and noise figure measurement systems, is the Agilent 346 family of broadband noise sources, which eliminate the necessity for several sources at different frequency bands. Each 346 noise source has individually-calibrated ENR values at specific frequencies.

A new feature of the 346 noise source family, is that every new noise source now comes with its own ENR data on a floppy disk for rapid entry of ENR data into the new Agilent Noise Figure Analyzers. The loaded data, includes a serial number and also a type identifier, A, B or C to reduce the risk of using a noise source with the wrong ENR data.

The calibration is printed on its label for easy loading into the noise figure analyzer, the 8970B, or any of the Agilent noise figure test systems. The low SWR of each noise source reduces a major source of measurement uncertainty and reflections of test signals. In addition, the variety of available connectors reduces the need for degrading accuracy with connector adapters.

The 346 family of noise sources are designed for a broad range of measurement applications. The 346A is especially designed for accurate characterization of input-impedance-sensitive devices (like GaAs FETs and many UHF amplifiers). Its very small change in reflection coefficient (<0.01) from ON to OFF minimizes errors when measuring noise figure and gain as a function of input impedance. The 346B's high ENR, low SWR, and variety of connectors make it a general-purpose noise source. The 346C covers the broadest frequency range 10 MHz to 26.5 GHz.

### Agilent 346A/B/C Partial Specifications

See Technical Data Sheet for complete specifications.

#### Frequency Range

346A/B: 10MHz to 18GHz

346C: 10MHz to 26.5GHz

#### Excess Noise Ratio (ENR) Limits

346A: 4.5 to 6.5 dB

346B: 14 to 16 dB

346C: 12 to 16 dB (10MHz to 12GHz) and 14 to 17 dB (12.0 to 26.5GHz)

#### Maximum SWR (reflection coefficient) On and Off

346A/B: 10 to 30MHz – 1.3 (0.13); 30 to 5GHz – 1.15 (0.07)

5 to 18 GHz – 1.25 (0.11)

346C: 10MHz to 18GHz – 1.25 (0.11); 18 to 26.5GHz – 1.35 (0.15)

#### Power Required: 28 ±1 Vdc

Size: 140 mm H x 21 mm W x 30 mm D ( 5.5 in x 0.8 in x 1.2 in)

Weight: net, 0.108 kg (3.5 oz); shipping, 0.5 kg (1 lb)

Standard Connector: 3.5mm (male)

### 346B Option H01 High ENR Noise Source

The 346B Option H01 has high ENR (21 dB typical), suitable for measuring high noise figure devices.\*

### 346B Option H42 DBS Noise Source

The 346B Option H42 was developed especially to test low noise block converters (LNB) used for Direct Broadcast Satellite (DBS). WR75 waveguide output, 5 dB ENR, low ENR calibration uncertainty, and low SWR improve the noise figure measurement accuracy of DBS LNBs.\*

### 346C Option K01 Broadband Noise Source

This coaxial noise source features coverage from 1 to 50 GHz with the 2.4 mm coaxial connector. ENR is nominally 20 dB at 1 GHz and 7 dB at 50 GHz.\*

\*Contact Agilent for technical specifications.

### R347B and Q347B Noise Sources

#### Partial Specifications

See Technical Data Sheet for complete specifications.

#### Frequency Range

R347B: 26.5 to 40 GHz

Q347B: 33 to 50 GHz

#### Excess Noise Ratio (ENR) Range

R347B: 10 to 13 dB

Q347B: 10 to 13 dB (33 to 42 GHz)

6 to 12.5 dB (42 to 50 GHz)

#### Maximum SWR (reflection coefficient)

R347B: <1.42 (0.17)

Q347B: <1.57 (0.22)

### Key Literature

346A/B/C Broadband Noise Sources Technical Data, p/n 5953-6452

### Ordering Information

#### 346A Noise Source

Opt 001 Type-N (male) Connector

Opt 002 7mm Connector

Opt 004 Type-N (female) Connector

Opt 910 Extra Operating Manual

Opt W30 Extended Repair Service

Opt W32 Calibration Service

#### 346B Noise Source

Opt 001 Type-N (male) Connector

Opt 002 7mm Connector

Opt 004 Type-N (female) Connector

Opt H01 High ENR

Opt H42 DBS Noise Source

Opt 910 Extra Operating Manual

Opt W30 Extended Repair Service

Opt W32 Calibration Service

#### 346C Noise Source

Opt 910 Extra Operating Manual

Opt W30 Extended Repair Service

Opt W32 Calibration Service

Opt K01 Noise Source

#### R347B Noise Source

#### Q347B Noise Source



- 10 to 1600MHz (2047 MHz with Option 20)
- Accurate and simple, swept or CW measurements
- Second stage correction
- Noise Figure and Gain display
- Calibrated display on oscilloscope, recorder or plotter
- Powerful special function enhancements
- LO control for downconverter test

8970B



8970B

### 8970B Noise Figure Meter

With the Agilent 8970B noise figure meter, noise figure measurements are easy, accurate, and repeatable. Automatic second-stage correction makes accurate noise figure readings possible even for low-gain devices. The 8970B's dynamic range allows gain measurements of at least 40 dB (higher in some cases) or loss measurements to  $-20$  dB, with no external attenuation or amplification. The 8970B can store up to four Excess Noise Ratio (ENR) noise source calibration tables. It also properly interpolates ENR values at each measurement frequency.

### Microprocessor and Controller Functions

The 8970B takes the mystery out of noise figure measurements. It uses a microprocessor to make the calculations and corrections necessary for truly accurate, convenient, and flexible noise figure measurements. The meter also controls external local oscillators (such as the 8370 series synthesizers, the 8340 or 8360 series synthesized sweepers, or the 8350 sweep oscillator) and the 8971C noise figure test set. This makes accurate, broadband microwave measurements of amplifiers, mixers, and transistors as simple as RF measurements. Virtually all of the 8970B's front-panel keys and functions are accessible over GPIB. The noise figure meter has an independent system interface bus (SIB) to control the 8971C and local oscillator. This additional bus frees you from having to write computer code to control an instrument on the SIB (such as the local oscillator) when used in an automated setup. Pass-through capability allows other instrument controllers to send messages through the noise figure meter to any other instrument on the SIB.

### Simple Calibration and Second-Stage Correction

Noise figure measurement accuracy is enhanced because the meter measures its own noise figure (and that of the rest of the measurement system) at up to 181 points. It stores this information, interpolates where necessary, and corrects for it when displaying the device under test noise figure. It also measures the test device gain.

### Display

The 8970B's front-panel LED's display frequency, gain, and noise figure. Rear-panel BNC connectors allow swept display of noise figure and gain versus frequency on an oscilloscope or x-y recorder. You can also have the noise figure and gain vs. frequency display sent to a digital plotter over the 8970B's system interface bus. All display modes are easily and accurately scaled to the desired resolution from the meter's front panel. The swept oscilloscope display allows you to optimize your test device in real time for both noise figure and gain. You can easily change the noise figure display from noise figure to effective noise temperature (Te) or Y factor.

### Front Panel and Special Functions

The 8970B front-panel keys control number entry, calibration, and measurement. STORE, RECALL, and SEQ keys allow up to nine front-panel settings to be stored and sequenced automatically or manually to save setup time. Smoothing INCREASE and DECREASE keys are used to average up to 512 readings before display. This increases accuracy and eliminates display flicker. For those who need greater measurement power than that provided by the 8970B's simple front panel, more than 200 special functions can be selected by pressing a numerical code and a special function key. Two examples are hot-cold measurements and automatic compensation for losses at the input of the test device. One of the special functions is a catalog that quickly shows you the current special functions being used. Three pull-out cards serve as a mini-reference manual for the instrument. They include most of the special functions, the GPIB formats and codes, error messages, and typical measurement setups.

### 8970B Partial Specifications

See Technical Data Sheet p/n 5091-6049E for complete specifications.

#### Noise Figure (Gain) Measurement Range:

0 to 30 dB ( $-20$  to at least 40 dB)

#### Noise Figure (Gain) Instrumentation Uncertainty:

$\pm 0.1$  dB for  $0^\circ$  to  $55^\circ$  C ( $\pm 0.15$  dB)

#### Noise Figure Resolution:

0.01 dB (0.001 dB over GPIB)

#### Gain Resolution:

0.01 dB (0.001 dB over GPIB)

#### Frequency Range:

Tunable from 10 to 1600MHz (2047MHz with Option 020)

#### Tuning Accuracy:

(from  $10^\circ$  to  $40^\circ$ C):  $\pm (1\text{MHz} + 1\%$  of frequency),  $\pm 6$  MHz maximum

#### Frequency Resolution:

1 MHz

#### Noise Figure (for input power levels below $-60$ dBm):

$< 7$  dB + 0.003 dB/MHz (+0.002 dB/MHz with option 020), Input SWR, 50 W reference impedance

$< 1.7$  10 MHz to 1600 MHz (SWR  $< 1.8$  with Opt 020)

$< 2.0$  1600 MHz to 2047 MHz (Opt 020 only)

#### Maximum Operating Input Power:

$-10$  dBm

#### Maximum Net External Gain:

$> 65$  dB between noise source and 8970B RF input

#### Noise Source Drive:

$28.0 \pm 0.1$  V

#### Operating Temperature:

$0^\circ$  C to  $55^\circ$  C

#### Storage Temperature:

$-55^\circ$  C to  $75^\circ$  C

#### Power:

100, 120, 220, or 240V (+5%,  $-10\%$ ); 48 to 66Hz; 150VA maximum

#### Size:

143 mm H x 425 mm W x 476 mm D (5.68 in x 16.75 in x 18.38 in)

#### Weight:

net, 15.5 kg (34 lb); shipping, 18.5 kg (40 lb)

### Key Literature

8970B, 8970S/V, 8971C Noise Figure Measurement Products

Technical Data, p/n 5091-6049E

8970S  
8970V  
8971C

- 10 MHz to 26.5 GHz
- Fully specified system
- Removes double-sideband inaccuracies
- As easy to operate as the 8970B

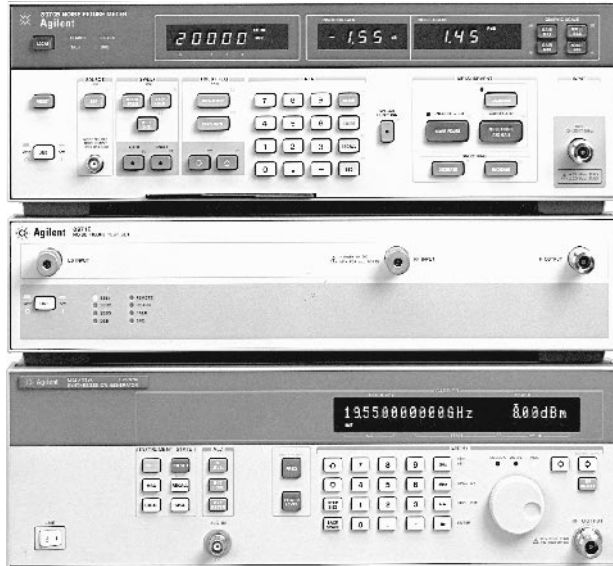

8970S/V

### 8970S/V Microwave Noise Figure Measurement Systems



The Agilent 8970S/V systems remove the burden of designing, building, and supporting a microwave noise figure measurement system. You can now spend your time designing and building products, not test systems. Each system consists of the 8970B noise figure meter, the 8971C noise figure test set, and a synthesized local oscillator. The 8970V system, which operates 10 MHz to 20 GHz, uses the 83711B synthesized CW generator as its local oscillator. The 8970S allows you to select the LO from the list below. Frequency operation depends on the LO selected, but can be configured to measure 10 MHz to 26.5 GHz with the 83630B synthesized sweeper. The 8971C with Option 001 is recommended for operation above 20 GHz. The 8970B acts as the controller, so all system operation is transparent to the user. To ensure specified performance, the 8970S/V systems are given specifications just like an RF noise figure meter (i.e., the 8970B).

#### Agilent 8970S/V Partial Specifications

See 8970S/V Technical Data for complete specifications.

##### Frequency Range

8970S: 10 MHz to 26.5 GHz

8970V: 10 MHz to 20 GHz

##### Noise Figure Measurement Range: 0 to 30 dB

**Noise Figure Instrumentation Uncertainty** (for a 14 to 16 dB ENR noise source in a 10° C to 40° C environment and for device under test noise figure plus gain greater than 10 dB): 10 MHz to 18 GHz: ±0.2 dB (plus typical drift of ±0.015 dB/° C) 18 to 26.5 GHz: ±0.4 dB (plus typical drift of ±0.08 dB/° C)

**Gain Instrumentation Uncertainty:** ±0.28 dB (plus typical drift of ±0.05 dB/° C), 10 MHz to 18 GHz; ±0.07 dB/° C, 18 to 26.5 GHz

##### Noise Figure (maximum)

10 to 30 MHz: 18 dB

30 to 100 MHz: 13 dB

0.1 to 12 GHz: 10 dB

12 to 18 GHz: 11.5 dB

18 to 26.5 GHz: 14 dB

**Input SWR:** 10 MHz to 18 GHz: 2.25; 18 to 26.5 GHz: 2.7

**Recommended Local Oscillators:** 83620B, 83622B, 83623B/L, 83624B, 83630B/L, 83640B/L, 83650B/L, 83711B, 83712B, 83731B, 83732B, 83751A/B, 83752 A/B



8971C

### 8971C Noise Figure Test Set



The Agilent 8971C noise figure test set brings the simplicity of double-sideband measurements and the accuracy of single-sideband measurements together in one package. Careful design and high-performance components, including a stable YIG filter, allow broadband single-side-band measurements from 10 MHz to 26.5GHz with a single calibration and sweep. A low-noise preamplifier built into the noise figure test set lowers the second-stage noise figure, thereby reducing a major source of measurement uncertainty. Measurement modes in the 8970B allow for double down-conversion using the 8971C as the second downconverter. These modes can be used for millimeter-wave measurements of amplifiers and transistors and measurements of receivers and mixers with IFs above 1.6 GHz.

#### 8971C Partial Specifications

See 8971C Technical Data for complete specifications.

**Frequency Range: 10 MHz to 26.5 GHz**

**Input SWR:** 10 MHz to 18 GHz: 2.25; 18 to 26.5 GHz: 2.7

**Image and Odd-Harmonic Rejection:** 20 dB

##### Accessories Supplied

One LO-to- 8971C cable, SMA (female), 300 mm

One 8971C-to- 8970B cable, Type-N (male), 190 mm

One Type-N (male)-to-SMA (male) adapter

Two GPiB cables, 0.5 m

#### Key Literature

8970B, 8970S/V, 8971C Noise Figure Measurement Products Technical Data, p/n 5091-6049E

#### Ordering Information

##### 8970B Noise Figure Meter

**Opt 020** 2047 MHz Upper Frequency

**Opt 907** Front-Panel Handle Kit (5061-9689)

**Opt 908** Rackmounting Flange Kit (5061-9677)

**Opt 909** Both Options 907 and 908 (5061-9683)

**Opt 915** Service Manual (08970-90023)

**Opt 916** Additional Operating Manual (08970-90048)

**Opt 700** External Mate Translator

**Opt W30** Extended Repair Service

**Opt W32** Calibration Service

##### 8971C Noise Figure Test Set

**Opt 001** Add L.O. Power Amplifier

**Opt 002** Delete RF Preamplifier

**Opt 907** Front-Panel Handle Kit (5062-3988)

##### 8970S Noise Figure Measurement System (10 MHz to 26.5 GHz)

##### 8970V Noise Figure Measurement System (10 MHz to 20 GHz)

**Opt W30** Extended Repair Service

**Opt W32** Calibration Service

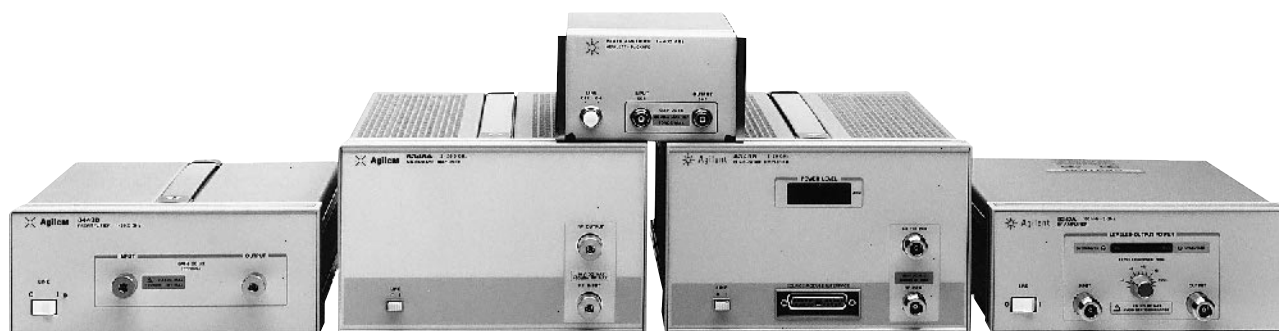

### 8347A and 8447A/D Amplifiers

#### Specifications Summary

**5**

	<b>8347A RF Amplifier</b>	<b>8447A Pre-amplifier</b>	<b>8447D Pre-amplifier</b>
<b>Frequency range</b>	100 kHz to 3 GHz	0.1 to 400 MHz	100 kHz to 1.3 GHz
<b>Typical 3 dB bandwidth</b>	—	50 kHz to 700 MHz	75 kHz to 1.7 GHz
<b>Maximum leveled output power</b>	≥ +20 dBm	—	—
<b>Output power leveling range</b>	(≥300 kHz): +2 to +20 dBm	—	—
<b>Gain (mean, per channel)</b>	≥25 dB	20 dB ± 1.0 dB at 10 MHz (20° to 30° C)	>25 dB (20° to 30° C)
<b>Gain flatness across full frequency range</b>	Internally leveled, ±300 kHz: ±1.5 dB	±1.8 dB (0° to 55° C) ±0.7 dB (20° to 30° C) characteristic	±1.5 dB
<b>Noise figure</b>	10 MHz to 3 GHz: 15 dB Below 10 MHz: 20 dB	<7 dB	<8.5 dB
<b>Output power for 1 dB gain compression</b>	+22 dBm	> +6 dBm	> +7 dBm typical
<b>Third-order intercept</b>	+30 dBm	—	—
<b>Harmonic distortion</b>	(at +20 dBm output) Internal level off (ALC off): ≤ -25 dBc Internal level on (ALC on): ≤ -20 dBc	-32 dB for 0 dBm output	-30 dB for 0 dBm output (typical)
<b>Maximum input for minimum internally leveled output</b>	-14 dBm	—	—
<b>Output for &lt;-60 dB harmonic distortion</b>	—	-25 dBm (characteristic)	-30 dBm
<b>VSWR</b>	2.0: 1 input 1.5: 1 output internally leveled 2.0: 1 output unleveled below 2 GHz 3.0: 1 output unleveled 2 GHz to 3 GHz	<1.7	<2.0 input <2.2 output 1 to 1300 MHz
<b>Reverse isolation</b>	60 dB	>30 dB	>40 dB
<b>Maximum dc voltage output</b>	—	±10 V	±10 V
<b>Size</b>	102 mm H x 213 mm W x 298 mm D (4.0 in x 8.4 in x 11.8 in)	85.8 mm H x 130 mm W x 261 mm D (3.4 in x 5.1 in x 8.5 in)	85.8 mm H x 130 mm W x 216 mm D (3.4 in x 5.1 in x 8.5 in)
<b>Weight</b>	Net, 4 kg (8 lb); Shipping, 5 kg (11 lb)	Net, 1.56 kg (3.4 lb); Shipping, 2.3 kg (5.1 lb)	Net, 1.56 kg (3.4 lb); Shipping, 2.3 kg (5.1 lb)
<b>Power requirements</b>	—	110 or 230 Vac + 10%, 48 to 440 Hz, 15 W	110 or 230 Vac + 10%, 48 to 440 Hz, 15 W
<b>Options available</b>	—	<b>Option 001:</b> Dual-channel amp, BNC (f) connectors	<b>Option 001:</b> Dual-channel amp, BNC (f) connectors <b>Option 010:</b> Single-channel amp, Type-N (f) connectors <b>Option 011:</b> Dual-channel amp, Type-N (f) connectors

#### Key Literature

8346A, 8347A, 8348A, 8349A Amplifiers Technical Data, p/n 5091-0370E

#### Ordering Information

**8347A** RF Amplifier  
**8447A** Pre-amplifier  
**8447D** Pre-amplifier

## 8348A Microwave Amplifier

### Specifications

**Frequency Range:** 2.0 to 26.5 GHz

**Maximum Output Power** (at 0 dBm input):

- 1.0 to 2.0 GHz:  $\geq +20$  dBm (typical)
- 2.0 to 20.0 GHz:  $\geq +25$  dBm
- 20.0 to 26.5 GHz:  $\geq +23$  dBm

**Power Flatness** (at 0 dBm input):  $\pm 4$  dB (typical)

**Minimum Small Signal Gain** (at  $-15$  dBm input):

- 1.0 to 2.0 GHz:  $\geq 20$  dB (typical)
- 2.0 to 20.0 GHz:  $\geq 25$  dB
- 20.0 to 26.5 GHz:  $\geq 23$  dB

### Spectral Purity

**Harmonics** (typical, at maximum specified output power):

- 1.0 to 2.0 GHz:  $< -20$  dBc
- 2.0 to 26.5 GHz:  $< -15$  dBc

### Third-Order Intercept

- 2.0 to 20.0 GHz:  $+36$  dBm, nominal
- 20.0 to 26.5 GHz:  $+31$  dBm, nominal

### Maximum Continuous Input

- Microwave power:  $+22$  dBm
- DC voltage:  $\pm 10$  V

**Input and Output Impedance:** 50  $\Omega$ , nominal

**Input SWR:** 3:1 (typical)

**Output SWR** (typical):

- 1.0 to 2.0 GHz: 6:1
- 2.0 to 20.0 GHz: 4.5:1
- 20.0 to 26.5 GHz: 2:1

**Reverse Isolation:**  $> 50$  dB (typical)

**Noise Figure** (typical):

- 1.0 to 20 GHz:  $< 10$  dB
- 20 to 26.5 GHz:  $< 13$  dB

### Pulse Transmission Capability

- Rise/Fall Time:**  $< 5$  ns (typical)
- Delay Time:**  $< 5$  ns (typical)

### General

**Input and Output Connectors:** 3.5 mm male

**Power Requirement:** 50 to 400 Hz, 100, 120, 200, or 240 volts ac ( $\pm 10\%$ ); 85 VA maximum

**Size:** 133 mm H x 214 mm W x 366 mm D (5.2 in x 8.4 in x 14.4 in)

**Weight:** Net, 7 kg (15 lb); shipping, 14 kg (31 lb)

### Ordering Information

**8348A** 2 to 26.5 GHz Microwave Preamplifier

## 8349B Microwave Amplifier

### Frequency Specifications

**Frequency Range:** 2 to 20 GHz

### Output and Input Specifications (25° C $\pm$ 5° C)

**Minimum Output Power** (at  $+5$  dBm input)

Frequency Range (HGz)	Output Leveled	Output Unleveled
2.0 to 18.6	19 dBm (80 mW)	20 dBm (100 mW)
18.6 to 20.0	17 dBm (50 mW)	18 dBm (63 mW)

**1 dB Compression Point:**  $+21$  dBm, nominal

**Power Flatness** (leveled):  $\pm 1.25$  dB

**Minimum Small Signal Gain** (at  $-5$  dBm input):

- 2.0 to 18.6 GHz: 15 dB
- 18.6 to 20.0 GHz: 13 dB

**Noise Figure:**  $< 13$  dB, typical

**Input and Output Impedance:** 50  $\Omega$ , nominal

### VSWR

Frequency Range (GHz)	Input	Output Leveled	Output Unleveled (typical)
2.0 to 5.0	$\leq 2.8$	$\leq 2.5$	$\leq 4.8$
5.0 to 11.0	$\leq 2.8$	$\leq 2.5$	$\leq 3.8$
11.0 to 18.0	$\leq 2.8$	$\leq 2.5$	$\leq 3.2$
18.0 to 20.0*	$\leq 2.8$	$\leq 2.5$	$\leq 3.2$

\*VSWR from 18.0 to 20.0 GHz is typical

**Maximum Continuous Input, to the Input or Output Ports:**

$+27$  dBm (RF),  $\pm 10$  Vdc

### Spectral Purity

**Harmonics** (at  $+20$  dBm output): 2.0 to 11.0 GHz:  $< -20$  dBc;

11.0 to 20.0 GHz:  $< -30$  dBc typical

**Non-Harmonic Spurious:**  $\leq -55$  dBc

**Third-Order Intercept:**  $+33$  dBm, nominal

### Pulse Transmission Capability

**Rise/Fall Time:**  $< 10$  ns typical

### General

**Reverse Isolation:**  $> 50$  dB, typical

**RF Input and Output Connectors:** Type-N female

**Size:** 133 mm H x 214 mm W x 366 mm D (5.2 in x 8.36 in x 13.6 in)

**Weight:** Net, 7 kg (15 lb); shipping, 14 kg (31 lb)

### Ordering Information

**8349B** 2 to 20 GHz Microwave Amplifier

**Opt 001** Rear Panel RF Input/Output

**Opt 002** Rear Panel RF Input w/Front Panel RF Output

**Opt W30** Extended Repair Service (see page 70)

## 8449B Preamplifier

### Specifications

<b>Frequency range</b>	1.0 to 26.5 GHz		
<b>Gain</b> (mean, per channel)	$\geq 26$ dB (20° C to 30° C)		
<b>Gain flatness across full freq. range</b>	1 to 26.5 GHz $\pm 4.5$ dB (0° C to 55° C); 2 to 22 GHz $\pm 2.4$ dB (20° C to 30° C)		
<b>Noise figure</b>	<b>Band</b>	<b>Typical</b>	
	1.0 to 12.7 GHz	$\leq 8.5$ dB	7 dB
	12.7 to 22.0 GHz	12.5 dB	9 dB
	22.0 to 26.5 GHz	$\leq 14.5$ dB	12 dB
<b>Output power for 1 dB gain compression</b>	$\leq +7$ dBm (characteristic)		
<b>Harmonic distortion</b>	$-30$ dB for 0 dBm output (characteristic)		
<b>Output for <math>&lt; -60</math> dB harmonic distortion</b>	$-30$ dBm (characteristic)		

VSWR	Input	1.0 to 2.0 GHz	2.0:1
		2.0 to 12.5 GHz	1.5:1
		12.5 to 26.5 GHz	2.0:1
	<b>Output</b>	1.0 to 26.5 GHz	2.0:1
<b>Reverse isolation</b>	$> 75$ dB		
<b>Maximum dc voltage</b>	$\pm 20$ V		

**Displayed average noise level, 0 dB atten.** (characteristic)

8563E (1 Hz RBW)	8566B (10 Hz RBW)
1.0 to 6.46 GHz, $-165$ dBm	1.0 to 2.5 GHz, $-55$ dBm
5.86 to 13.0 GHz, $-163$ dBm	2.0 to 5.8 GHz, $-154$ dBm
12.4 to 26.5 GHz, $-160$ dBm	5.8 to 12.5 GHz, $-150$ dBm
	12.5 to 18.6 GHz, $-144$ dBm
	18.6 to 22 GHz, $-140$ dBm

**Size:** 102 mm H x 213 mm W x 297 mm D (4.0 in x 8.4 in x 11.7 in)

**Weight:** Net, 4 kg (8.8 lb) nominal

**Power:** 100, 120, 220, or 240 V,  $\pm 10\%$ ; 47 to 63 Hz

### Ordering Information

**8449B** 1 to 26.5 GHz Preamplifier

**Opt 907** Front Handle Kit

**Opt 908** Rackmount Kit (half-rack width)



- Ultra broadband to 50 GHz
- Up to 1 watt output power
- Compact size

### Microwave System Amplifiers

Use these amplifiers to increase output power from microwave sources and to increase test system measurement speed with improved dynamic range. Drive a variety of narrowband travelling wave tubes with a single driver solution that is highly reliable and low in cost to maintain year after year. With excellent noise figure relative to its broad bandwidth and high gain, these amplifiers can make significant improvement to system noise figure. By using feedback to an external source ALC input, system designers can level output power at the test port, negating the effects of post sweeper reflections and losses. Place power where you need it with a remotely-locatable dc power supply. The amplifier and the power supply are provided with a 2-m dc bias cable.



### Specifications (+20° C to +30° C)

Model	Frequency (GHz)	Power out Psat (dBm)	Power out P1dB (dBm)	Gain dB (min)	Noise figure (dB typ.)	Detected output	DC bias volt/amp	RF connectors (Input/Output)
83006A	0.01 to 26.5	+18 typ. 0.01 to 10 +16 typ. 10 to 20 +14 typ. 20 to 26.5	+13, 0.01 to 20 +10, 20 to 26.5	20	13, 0.01 to 0.1 GHz 8, 0.1 to 18 GHz 13, 18 to 26.5 GHz	No	+12 V at 450 mA -12 V at 50 mA	3.5 mm (f)
83017A	0.5 to 26.5	+20 typ. 0.5 to 20 +15 typ. 20 to 26.5	+18, 0.5 to 20 GHz +13, 20 to 26.5	25	8, 0.5 to 18 GHz 13, 18 to 26.5 GHz	Yes	+12 V at 700 mA -12 V at 50 mA	3.5 mm (f)
83018A	2 to 26.5	+24, 2 to 20 GHz +21, 20 to 26.5 GHz	+22, 2 to 20 GHz +17, 20 to 26.5 GHz	27, 2 to 20 GHz 23, 20 to 26.5 GHz	10, 2 to 20 GHz 13, 20 to 26.5 GHz	Yes	+12 V at 2 A -12 V at 50 mA	3.5 mm (f)
83020A	2 to 26.5	+30, 2 to 20 GHz +30, 20 to 26.5 GHz*	+28, 2 to 20 GHz +28, 20 to 26.5 GHz*	30, 2 to 20 GHz 27, 20 to 26.5 GHz	10, 2 to 20 GHz 13, 20 to 26.5 GHz	Yes	+15 V at 3.2 A -15 V at 50 mA	3.5 mm (f)
83050A	2 to 50	+20, 2 to 40 GHz +19, 40 to 50 GHz**	+15, 2 to 40 GHz +13, 40 to 50 GHz	21	6, 2 to 26.5 GHz 10, 26.5 to 50 GHz	No	+12 V at 830 mA -12 V at 50 mA	2.4 mm (f)
83051A	0.045 to 50	+12, .045 to 45 GHz +10, 45 to 50 GHz	+8, .045 to 45 GHz +6, 45 to 50 GHz	23	12, 0.045 to 2 GHz 6, 2 to 26.5 GHz 10, 26.5 to 50 GHz	No	+12 V at 425 mA -12 V at 50 mA	2.4 mm (f)
87405A	0.01 to 3	+26 typ.	+4	22-27 min./max.	6.5, 0.01 to 2 GHz 7.5, 2 to 3 GHz	No	+15 V at 80 mA	N (f)/N (m)
87415A	2 to 8	+26 typ.	+23	25	13	No	+12 V at 900 mA	SMA (f)

\* -0.7 dB/GHz (20<f<26.5)

\*\* 19 dBm -0.2 dB/GHz (40<f<50)

#### Dimensions:

**83006A, 83017A, 83050A, 83051A, 87415A:** 45 mm H x 103 mm W

x 132 mm L (5.2 in x 1.8 in x 4 in)

**83018A:** 76 mm H x 114 mm W x 212 mm L (8.3 in x 3 in x 4.5 in)

**83020A:** 87 mm H x 202 mm W x 275 mm L (10.8 in x 3.4 in x 8 in)

**87405A:** 28 mm H x 28 mm W x 125 mm L (1.1 in x 1.1 in x 4.9 in)

#### Weight:

**83006A, 83017A, 83050A, 83051A, 87415A:** .64 kg (1.4 lb);

**83018A:** 1.8 kg (4 lb); **83020A:** 3.9 kg (8.5 lb);

**87405A:** .27 kg (0.6 lb)

#### Bias Cable:

2-m cable with a connector on one end and bare wires on the other, shipped with the amplifiers below

**83006A, 83017A, 83018A, 83050A, 83051A, 87415A:**

p/n 83006-60004

**83020A:** p/n 83020-60004

2-m cables to connect between amplifier and power supplies, shipped with power supplies below

**87421A:** p/n 83006-60005

**87422A:** p/n 87422-60001, 83006-60005

Power supply	AC Input voltage	DC Output voltage/current	Output power	Size (H,W,D)
87421A	100 to 240 VAC 50/60 Hz	+12 V at 2.0 A, -12 V at 200 mA	25 W max	57 mm, 114 mm, 176 mm (2.3 in, 4.5 in, 6.9 in)
87422A	100 to 240 VAC 50/60 Hz	+15 V at 3.3 A, -15 V at 50 mA +12 V at 2.0 A, -12 V at 200 mA	70 W max	86 mm, 202 mm, 276 mm (3.4 in, 8.0 in, 10.9 in)

### Key Literature

Latest RF & Microwave Test Accessories Catalog, p/n 5968-4314EUS

For more information, visit our web site: <http://www.agilent.com/find/MTA>



87130A

### 11713A Attenuator/Switch Driver

The 11713A attenuator/switch driver provides simple GPIB control of up to ten, 24 Vdc solenoid-activated switch or attenuator sections. The 11713A supplies 24 Vdc common and ten pairs of current sinking contacts to achieve control of up to ten relays. Each 11713A is supplied with two plug-in drive cables to simplify connection to programmable attenuators.

### 70611A Attenuator/Switch Driver for MMS

The 70611A is a one-slot MMS module capable of driving up to 248 electromechanical switches or attenuator switch sections. The 70611A is MSIB, SCPI, and GPIB compatible. In addition to being programmable, the 70611A features an extremely user-friendly manual interface via any MMS display unit. The highlight of the manual interface is the operator's ability to customize groups of switch control lines and their settings, then identify these switch settings with user-defined alphanumeric labels. In this manner, end users of the 70611A can define custom menus with their own identification labels for simplified manual control.

The 70611A can store up to 256 user-defined labeled paths. Path definitions can be stored in non-volatile EEROM. Groups of paths can be stored in directories for easy access to similar path commands. The 70612A/C and 70613A/C offer compatible capacity with built-in RF switches. (Configurations vary and custom configurations are available.)

### 87130A Attenuator/Switch Driver

The 87130A is a 3.5-inch, full rack width attenuator/switch driver capable of driving up to 248 electromechanical switch or attenuator sections. The 87130A is controlled over GPIB via Standard Commands for Programmable Instruments (SCPI) commands. The 87130A has been designed for use in both ATE switching systems and computer-controlled bench top applications.

The 87130A is electronically identical to the 70611A and shares its performance characteristics, with the exception of the manual control method. The 87130A has no front panel controls. Manual control of the 87130A is realized through its ITG driver and a computer controller. The 87130A can drive 31 switch or attenuator sections directly, and up to an additional 217 switches via seven additional 84940A driver cards.

### E1368A, E1369A and E1370A VXI Attenuator/Switch Drivers

Agilent's VXI family of instrumentation includes modules for microwave switching and attenuation control up to 18.0 GHz. E1368A contains three factory-installed SPDT switches such as the 8762B which features all-port termination, dc to 18.0 GHz. E1369A is identical to the E1368A except the switches are not included. This allows user-substitution of 8763 or 8764 transfer switches. E1370A allows the user to customize the internal configuration for 8766 series multi-port switches or 8494/95/96/97 step attenuators.

### 84940A Switch Driver and 84941A Distribution Card

The 84940A is an expansion driver card for the 70611/12/13 family of MMS attenuator/switch drivers and the 87130A attenuator/switch driver. The 84940A has been designed for incorporation into large interfaces located remotely from their controller. A single 84940A can control up to 31 switches when located up to 150 feet (45 m) from an 70611/12/13 or 87130A. The physical interconnection to the switches or attenuators is realized via 31 four-pin output connectors, which permit quick connection and disconnection of the switches or attenuators.

### Key Literature

Latest RF & Microwave Test Accessories Catalog, p/n 5968-4314E

For more information, visit our web site:

<http://www.agilent.com/find/mta>

### Ordering Information

- 11713A Attenuator/Switch Driver
- 11761A; 8765 to 11713A Adapter Cable
- 44476B Microwave Switch Module for 3488A (Holds up to two 8762/3/4 Option 011 Switches)
- 70611A MMS Switch Driver
- 84940A Attenuator/Switch Driver Expansion Card
- 84941A Distribution Expansion Card
- 87130A Attenuator/Switch Driver
- E1368A 18 GHz Microwave Switch
- E1369A Microwave Switch Driver
- E1370A Microwave Switch/Step Attenuator Driver

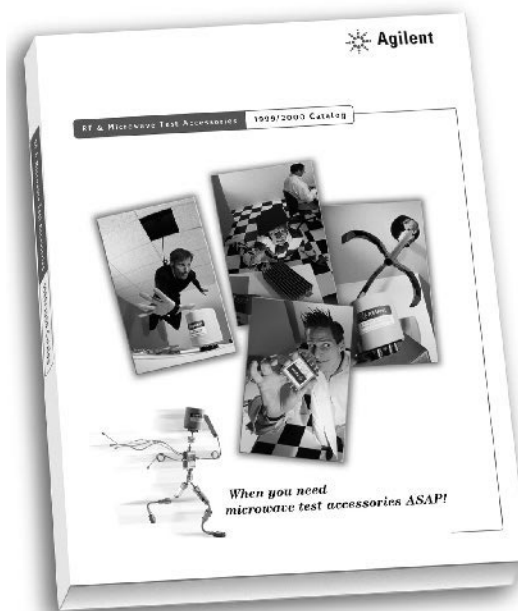

### RF & Microwave Test Accessories Catalog

The complete catalog of Agilent's microwave accessories—from adapters to waveguides and everything between, it's all here. Amplifiers, detectors, filters, step and fixed attenuators, switches and switch drivers—the entire Agilent Technologies product line, with all the technical specs.

To receive your free copy in the U.S., call 800-452-4844 and ask for the *RF & Microwave Test Accessories Catalog*, p/n 5968-4314E, contact your local Agilent representative, or order on the Internet. The entire Test & Measurements catalog can be accessed at: [http://www.agilent.com/find/mta\\_catalog](http://www.agilent.com/find/mta_catalog)

- Low SWR
- Low insertion loss
- High isolation—up to 134 dB @ 4 GHz!
- Long life—5 million cycles!
- Excellent repeatability

### Coaxial Switches

Featuring unparalleled reliability and the longest life available, Agilent switches are the clear choice for high volume wireless communications manufacturing test. All switches utilize magnetically latched solenoids and break-before-make RF contacts for test simplicity. In precision measurements and monitoring applications where insertion loss repeatability is crucial, these switches will operate in excess of 5 million cycles with better than .03dB of insertion loss repeatability at 25 ° C.

#### N1810UL—Unterminated Latching SPDT

The 1810UL is a single-pole, double throw switch available in the frequency range from DC to 26.5GHz.

#### N1810TL—Terminated Latching SPDT

The 1810TL is a single-pole, double throw switch available in the frequency range from DC to 26.5 GHz. The unused port is terminated into 50 Ω, making it ideal for applications where source matching is required.

#### N1811TL—Terminated Latching Bypass

The 1811TL is a terminated bypass switch available in the frequency range from DC to 26.5 GHz. The switch's internal load can terminate the device under test when in the through mode (up to 1 watt). Because of its compact design, it is ideal for drop-in, drop-out applications.

#### N1812UL—Unterminated Latching 5-port

The 1812UL is a versatile, unterminated 5-port switch available in the range of frequency from DC to 26.5 GHz. In bypass switch applications, the fifth port can be terminated externally with a high power termination. It can also be utilized for signal path reversal or as a calibration port.

### Key Literature

N1810/1/2 Coaxial Switches Product Overview, p/n 5968-9653E

### Ordering Information

Required (specify frequency, voltage, and dc connector type)		N1810UL	N1810TL	N1811TL	N1812UL
Base price					
Frequency	<b>002</b>	dc – 2GHz w/SMA(f) RF connector			
	<b>004</b>	dc – 4GHz w/SMA(f) RF connector			
	<b>020</b>	dc – 20GHz w/SMA(f) RF connector			
	<b>026</b>	dc – 26.5GHz w/SMA(f) RF connector			
Voltage	<b>105</b>	5 volts			
	<b>115</b>	15 volts			
	<b>124</b>	24 volts			
dc Connector	<b>201</b>	D-subminiature 9 pin (f)			
	<b>202</b>	Solder lugs			
<b>Options</b>					
Performance (chose any)	<b>301</b>	Higher isolation (see specs)			
	<b>302</b>	Low SWR and insertion loss (see specs)			
Drive (chose any)	<b>401</b>	TTL/5V CMOS compatible drive			
	<b>402</b>	Position Indicators			
	<b>401</b>	Current Interrupts			

Ordering example: For an unterminated 5-port switch, operating up to 20GHz, with 15 volt coils, D-sub connector, TTL drive, and high isolation, the order should look as follows: **N1812UL Opt 020 115 201 301 401**

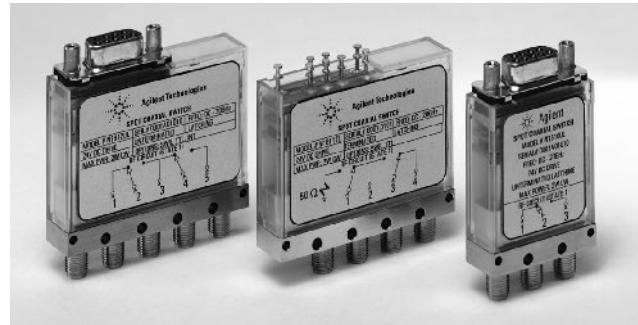

N181x Series

#### General operating characteristics: N181x series

Switching speed	Repeatability	Life	Impedance
<15 ms	<.03 db typical	5 mil cycles	50 Ω

#### Standard performance specifications: N181x series

	dc	4 GHz	12.4 GHz	20 GHz	26.5 GHz
Isolation (dB)	90	85	76	67	60
Insertion Loss (dB)	= 0.2 + 0.5/26.5 x F, where F is specified in GHz				
	dc	4 GHz	12.4 GHz	20 GHz	26.5 GHz
	0.20	0.28	0.43	0.58	0.70
SWR	dc–2 GHz	2–4 GHz	4–12.4 GHz	12.4–20 GHz	20–26.5 GHz
	1.10	1.15	1.20	1.30	1.60

#### Optional high performance specifications: N181x series

Isolation (dB)	= 140 – 1.5 x F, where F is specified in GHz				
	dc	4 GHz	12.4 GHz	20 GHz	26.5 GHz
Opt. 301	140	134	121	110	100
Insertion Loss (dB)	= 0.15 + 0.013 x F, where F is specified in GHz				
	dc	4 GHz	12.4 GHz	20 GHz	26.5 GHz
Opt. 302	0.15	0.20	0.31	0.41	0.50
SWR	dc–2 GHz	2–4 GHz	4–12.4 GHz	12.4–20 GHz	20–26.5 GHz
Opt. 302	1.05	1.10	1.15	1.20	1.40

N1810UL  
N1810TL  
N1811TL  
N1812UL

8761  
8762  
8763  
8764  
8765 Series

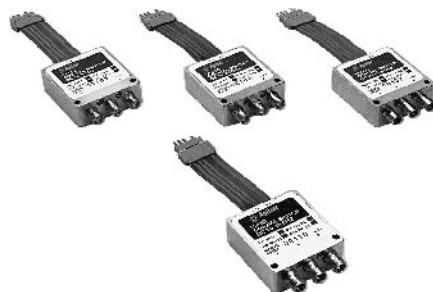

### Coaxial Switches

Agilent coaxial switches feature low SWR, low insertion loss, and excellent isolation. Agilent offers a broad line of coaxial switches, covering up to 40 GHz, for use in test and measurement applications. All switches use magnetically-latched solenoids and break-before-make RF contacts for test simplicity.

#### 8761 Series

8761A/B is a SPDT switch which operates up to 18 GHz. Each port features six connector options plus 50 Ω termination for design flexibility. These switches offer exceptional repeatability of 0.03 dB over 1 million switching cycles.

#### 8762 Series

8762A/B/C switches operate up to 26.5 GHz. These switches offer exceptional repeatability of 0.03 dB over 1 million switching cycles. They also provide excellent isolation of 90 dB to 18 GHz and all-port switched terminations, so that all ports maintain a 50 Ω match. Internal loads are rated at 1 watt average (100 W peak, 10 μsec pulse width). Control voltage options T15 and T24 are compatible with TTL/5 V CMOS drive circuitry. Another model, 8762F is designed for 75 Ω transmission lines, making it valuable for commercial communication applications up to 4 GHz.

#### 8763 Series

8763A/B/C switches operate up to 26.5 GHz. These switches offer exceptional repeatability of 0.03 dB over 1 million switching cycles. They are preferred for drop-out or drop-in applications due to their compact design. These switches are used to automatically insert or remove a test component from a signal path. Because of their excellent isolation, they can also be used as the intersection (crosspoint) switch in full-access matrix switching applications. One port is internally terminated. Options T15 and T24 are available for TTL/5 V CMOS compatibility.

#### 8764 Series

8764A/B/C switches are available in three models up to 26.5 GHz. These switches offer exceptional repeatability of 0.03 dB over 1 million switching cycles. These switches are similar to the 8763, but with the internal termination replaced with a fifth port. The fifth port can be utilized for signal path reversal or as a calibration port. Options T15 and T24 offer TTL/5V CMOS compatibility.

#### 8765 Series

8765A/B/C/D/F are available in four models up to 40 GHz, as well as a 75 Ω model to 4 GHz. These SPDT switches offer exceptional repeatability of 0.03 dB over 5 million switching cycles. Unlike the 8762 switches, they do not have internal, switched RF loads or dc current interrupts. Coil voltage options cover the complete range from 5 Vdc to 24 Vdc. Since the coils are not interrupted, the coil voltage may be continuous or may be switched off after 15 ms.

The standard 8765 comes with ribbon cables and standard printed circuit board 0.025-inch connector for convenient assembly. The ribbon cable also connects with the 11761A Cable/Adapter, which permits direct connection to the 11713A Attenuator/Switch Driver. The 8765 can also be driven by the 87130A driver, but position monitoring and reporting are not available. Optional solder terminals are available.

### Key Literature

Latest RF & Microwave Test Accessories Catalog, p/n 5968-4314E

### Ordering Information

#### 8761A/B Coaxial Switches

Specify voltage and connectors (including built-in 50 Ω terminations) by alphabetic suffix on the switch model number and the appropriate 3-digit option number. Specify all connectors.

**8761A** 12 to 15 V Supply Voltage

**8761B** 24 to 30 V Supply Voltage

**Connector Options** (Port 1, Port 2, Port C):

Option Code	Connector Type
0	Type-N(f)
1	Type-N(m)
2	APC-7 w/threaded sleeve
3	APC-7 w/coupling nut
4	APC-7 for UT-250 coax
5	SMA(f)
6	SMA(m)
7	50 Ω termination

#### 8762, 8763, 8764 Coaxial Switches

Specify the frequency and voltage by the alphabetic suffix and option number. The standard model has 24 V supply voltage.

**8762A** SPDT, DC to 4 GHz

**8762B** SPDT, DC to 18 GHz

**8762C** SPDT, DC to 26.5 GHz

**8762F** SPDT, DC to 4 GHz, 75 Ω

**8763A** 4-Port, DC to 4 GHz

**8763B** 4-Port, DC to 18 GHz

**8763C** 4-Port, DC to 26.5 GHz

**8764A** 5-Port, DC to 4 GHz

**8764B** 5-Port, DC to 18 GHz

**8764C** 5-Port, DC to 26.5 GHz

**Opt 011** 5 Vdc Supply Voltage

**Opt 015** 15 Vdc Supply Voltage

**Opt T15** TTL/5 V CMOS Compatible Logic

with 15 Vdc Supply Voltage

**Opt T24** TTL/5 V CMOS Compatible Logic

with 24 Vdc Supply Voltage

**Opt UK6** Commercial Calibration Test Data with Certificate

#### 8765 Coaxial Switches

A voltage option must be ordered with the switch. Specify frequency, voltage, dc connectors, and ribbon cable extension options by alphabetic suffix and option number.

**8765A** SPDT, DC to 4 GHz

**8765B** SPDT, DC to 20 GHz

**8765C** SPDT, DC to 26.5 GHz

**8765D** SPDT, DC to 40 GHz

**8765F** SPDT, DC to 4 GHz, 75 Ω

**Opt 005** 5 Vdc Supply Voltage

**Opt 010** 10 Vdc Supply Voltage

**Opt 015** 15 Vdc Supply Voltage

**Opt 024** 24 Vdc Supply Voltage

**Opt 100** Solder Terminals

**Opt 108** 8-in Ribbon Cable Extension

**Opt 116** 16-in Ribbon Cable Extension

**Opt 292** 2.92 mm (f) Connector<sup>1</sup>

**Opt UK6** Commercial Calibration Test Data with Certificate<sup>2</sup> (8765A/B/C/D only)

<sup>1</sup>Option 292 available for 8765D only.

<sup>2</sup>8765D Option 292 and 8765F do not have Option UK6.



### 8761–5 Series Specifications

8761  
8762  
8763  
8764  
8765 Series

Model	Frequency Range (GHz)	SWR 50 Ω Nominal	Insertion Loss	Isolation	Switching Speed	Repeat-ability <sup>2</sup>	Life <sup>3</sup>	RF Connectors	Dimensions W x H x D (mm)	Shipping Weight (g)
<b>8761A</b> SPDT Unterminated	dc to 18	<1.2 to 12.4 GHz <1.25 to 18 GHz	<0.5 dB to 12.4 GHz <0.8 dB to 18 GHz	>50 dB to 12.4 GHz >45 dB to 18 GHz	35 to 50 mS	0.03 dB	1 x 10 <sup>6</sup>	See table on page 30.3	38 x 41 x 38	300
<b>8761B</b> SPDT Unterminated	dc to 18	<1.2 to 12.4 GHz <1.25 to 18 GHz	<0.5 dB to 12.4 GHz <0.8 dB to 18 GHz	>50 dB to 12.4 GHz >45 dB to 18 GHz	35 to 50 mS	0.03 dB	1 x 10 <sup>6</sup>	See table on page 30.3	38 x 41 x 38	300
<b>8762A</b> SPDT Terminated	dc to 4	<1.1 to 2 GHz <1.2 to 4 GHz	<0.2 db to 2 GHz <0.25 dB to 4 GHz	>100 dB to 4 GHz	<30 mS	0.03 dB	1 x 10 <sup>6</sup>	SMA (f)	53 x 14 x 54	220
<b>8762B</b> SPDT Terminated	dc to 18	<1.10 to 2 GHz <1.2 to 12.4 GHz <1.3 to 18 GHz	<0.2 dB to 2 GHz <0.5 dB to 18 GHz	>90 dB to 18 GHz	<30 mS	0.03 dB	1 x 10 <sup>6</sup>	SMA (f)	53 x 14 x 54	220
<b>8762C</b> SPDT Terminated	dc to 26.5	<1.15 to 2 GHz <1.25 to 12.4 GHz <1.4 to 18 GHz <1.8 to 26.5 GHz	<0.25 dB to 2 GHz <0.5 dB to 18 GHz <1.25 dB to 26.5 GHz	>90 dB to 18 GHz >50 dB to 26.5 GHz	<30 mS	0.03 dB	1 x 10 <sup>6</sup>	3.5 mm (f)	53 x 14 x 54	220
<b>8762F</b> SPDT, 75 Ω Terminated	dc to 4	<1.15 to 1 GHz <1.3 to 4 GHz	<0.4 dB to 4 GHz	>100 dB to 4 GHz	<30 mS	0.03 dB	1 x 10 <sup>6</sup>	75 Ω, SMB (m)	53 x 14 x 54	300
<b>8763A</b> Coaxial Terminated	dc to 4	<1.1 to 2 GHz 1.2 to 4 GHz	<0.2 dB to 2 GHz <0.25 dB to 4 GHz	>100 dB to 4 GHz	<30 mS	0.03 dB	1 x 10 <sup>6</sup>	SMA (f)	53 x 14 x 54	220
<b>8763B</b> Coaxial Terminated	dc to 18	<1.10 to 2 GHz <1.2 to 12.4 GHz <1.3 to 18 GHz	<0.2 dB to 2 GHz <0.5 dB to 18 GHz	>90 dB to 18 GHz	<30 mS	0.03 dB	1 x 10 <sup>6</sup>	SMA (f)	53 x 14 x 54	220
<b>8763C</b> Coaxial Terminated	dc to 26.5	<1.15 to 2 GHz <1.25 to 12.4 GHz <1.4 to 18 GHz <1.8 to 26.5 GHz	<0.25 dB to 2 GHz <0.5 dB to 18 GHz <1.25 to 26.5 GHz	>90 dB to 18 GHz >50 dB to 26.5 GHz	<30 mS	0.03 dB	1 x 10 <sup>6</sup>	3.5 mm (f)	53 x 14 x 54	220
<b>8764A</b> Coaxial Unterminated	dc to 4	<1.1 to 2 GHz <1.2 to 4 GHz	<0.2 dB to 2 GHz <0.25 dB to 4 GHz	>100 dB to 4 GHz	<30 mS	0.03 dB	1 x 10 <sup>6</sup>	SMA (f)	53 x 14 x 54	220
<b>8764B</b> Coaxial Unterminated	dc to 18	<1.10 to 2 GHz <1.2 to 12.4 GHz <1.3 to 18 GHz	<0.2 dB to 2 GHz <0.5 dB to 18 GHz	>90 dB to 18 GHz	<30 mS	0.03 dB	1 x 10 <sup>6</sup>	SMA (f)	53 x 14 x 54	220
<b>8764C</b> Coaxial Unterminated	dc to 26.5	<1.15 to 2 GHz <1.25 to 12.4 GHz <1.4 to 18 GHz <1.8 to 26.5 GHz	<0.25 dB to 2 GHz <0.5 dB to 18 GHz <1.25 dB to 26.5 GHz	>90 dB to 18 GHz >50 dB to 26.5 GHz	<30 mS	0.03 dB	1 x 10 <sup>6</sup>	3.5 mm (f)	53 x 14 x 54	220
<b>8765A</b> SPDT Unterminated	dc to 4	<1.2 to 4 GHz	0.2 + 0.025 f (GHz) max <0.2 to 4 GHz <sup>1</sup>	>120 dB to 4 GHz	<15 mS	0.03 dB	5 x 10 <sup>6</sup>	SMA (f)	33 x 14 x 45	200
<b>8765B</b> SPDT Unterminated	dc to 20	<1.2 to 4 GHz <1.35 to 12.4 GHz <1.45 to 18 GHz <1.7 to 20 GHz	0.2 + 0.025 f (GHz) max <0.2 to 4 GHz <sup>1</sup> <0.5 to 20 GHz <sup>1</sup>	>120 dB to 4 GHz >90 dB to 20 GHz	<15 mS	0.03 dB	5 x 10 <sup>6</sup>	SMA (f)	33 x 14 x 45	200
<b>8765C</b> SPDT Unterminated	dc to 26.5	<1.25 to 4 GHz <1.45 to 18 GHz <1.7 to 26.5 GHz	0.25 + 0.027 f (GHz) max <0.2 to 4 GHz <sup>1</sup> <0.5 to 20 GHz <sup>1</sup> <0.7 to 26.5 GHz <sup>1</sup>	>120 dB to 4 GHz >90 dB to 20 GHz >60 dB to 26.5 GHz	<15 mS	0.03 dB	5 x 10 <sup>6</sup>	3.5 mm (f)	33 x 14 x 45	200
<b>8765D</b> SPDT Unterminated	dc to 40	<1.25 to 4 GHz <1.45 to 26.5 GHz <1.7 to 40 GHz	0.2 + 0.23 f (GHz) max <0.2 to 4 GHz <sup>1</sup> <0.5 to 20 GHz <sup>1</sup> <0.7 to 26.5 GHz <sup>1</sup> 0.75 + .023 f (GHz) max <1.0 to 40 GHz <sup>1</sup>	>120 dB to 4 GHz >90 dB to 20 GHz >60 dB to 26.5 GHz >50 dB to 40 GHz	<15 mS	0.03 dB	5 x 10 <sup>6</sup>	2.4 mm (f) 2.92 mm (f) Option 292	33 x 14 x 45	200
<b>8765F</b> SPDT, 75 Ω Unterminated	dc to 4	<1.15 to 1 GHz <1.20 to 4 GHz	<0.18 dB to 1 GHz <0.24 dB to 2 GHz <0.40 dB to 4 GHz	>100 dB to 1 GHz >90 dB to 4 GHz	<15 mS	0.03 dB	5 x 10 <sup>6</sup>	75 Ω, SMB (m)	33 x 14 x 45	200

<sup>1</sup>Typical insertion loss

<sup>2</sup>Measured at 25 °C

<sup>3</sup>Cycles per section minimum

For more information, visit our web site: <http://www.agilent.com/find/mta>

87104  
87106 Series  
87204  
87206 Series  
87222  
87406  
87606  
8766  
8767  
8768  
8769 Series



87222C/E



87406B



87204B

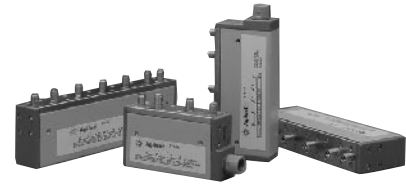

8766

### Transfer Switches—High Performance

The 87222C/E 4-port, coaxial transfer switches offer versatility in a number of applications from drop-out to signal reversal. They provide exceptional repeatability < .03 dB, a low insertion loss and high isolation. The 87222C operates from dc-26.5 GHz and is warranted for 5 million cycles. The 87222E operates from dc-50 GHz. The standard 87222C provides a 10-pin connector while Option 100 includes solder terminals. Option 201 provides a mounting bracket.

### Matrix Switches—High Performance, Terminated

#### 87406/606 Series

The 87406B and 87606B 6-port, coaxial matrix switches will provide a valuable tool for 3x3, 2x4, and 1x5 configurations. These high performance matrix switches offer excellent repeatability and life greater than 5 million cycles. The 87406B, 87606B operate from dc to 20 GHz with excellent isolation, VSWR < 2.0:1, and with an input power of 1 W avg./50 W peak (10 μs max). The standard 87406B/606B provide a 16-pin connector while Option 100 provides solder terminals. Option T24 is available which provides internal circuits that are compatible with external TTL/5 V CMOS digital ICs.

### Multiport—High Performance, Terminated

#### 87104/106 and 87204/206 Series

87104A/B/C and 87106A/B/C multiport switches are available in 3 models up to 26.5 GHz. These switches offer exceptional repeatability of 0.03 dB over 5 million switching cycles. 87104 is a Single-Pole-4-throw (SP4T) and 87106 is a SP6T function. Both switches have internal solid-state logic that automatically programs the non-used ports to a matched load when any one port is programmed to “on.” This relieves the user from having to provide external logic drive pulses.

87204A/B/C and 87206A/B/C switches are fully equivalent to models 87104/06 in their RF switching performance. However, their drive circuits are primarily designed to work with the 87130A/11760A switch drivers. These switches do not provide independent position indicators. The standard 87204/06 provides a 16-pin connector while Option 100 provides solder terminals.

### Multiport—Low Profile, Unterminated

#### 8766/67/68/69K Series

8766/67/68/69K series switches are modified versions of the 8494/95/96/97 series step attenuators (dc-26.5 GHz) for applications requiring a single-pole, 3-throw, 4-throw, 5-throw or 6-throw coaxial switch. The switch ports are unterminated. These switches offer exceptional repeatability of 0.03 dB over 5 million switching cycles. The switches are available with several optional cables and connectors to make them compatible with standard 14-pin DIP sockets. Isolation and insertion loss vary with frequency, and depend upon the port selected.

### Key Literature

Latest RF & Microwave Test Accessories Catalog, p/n 5968-4314E

For more information, visit our web site:

<http://www.agilent.com/find/mta>

### Ordering Information

- 87104A SP4T, DC to 4 GHz
  - 87104B SP4T, DC to 20 GHz
  - 87104C Transfer, DC to 26.5 GHz
  - 87106A Transfer, DC to 4 GHz
  - 87106B Matrix, DC to 20 GHz
  - 87106C Matrix, DC to 26.5 GHz
  - 87204A<sup>1</sup> SP4T, DC to 4 GHz
  - 87204B<sup>1</sup> SP4T, DC to 20 GHz
  - 87204C<sup>1</sup> SP4T, DC to 26.5 GHz
  - 87206A<sup>1</sup> SP6T, DC to 4 GHz
  - 87206B<sup>1</sup> SP6T, DC to 20 GHz
  - 87206C<sup>1</sup> SP6T, DC to 26.5 GHz
  - 87222C Transfer, DC to 26.5 GHz
  - 87222D Transfer, DC to 40 GHz
  - 87222E Transfer, DC to 50 GHz
  - Opt 201<sup>2</sup> Mounting Bracket
  - 87406B Matrix, DC to 20 GHz
  - 87606B Matrix, DC to 20 GHz
  - Opt 100 Solder Terminals
  - Opt T24<sup>4</sup> TTL/5 V CMOS Compatible Logic
  - Opt T00<sup>2,4</sup> Solder Terminals to Replace Ribbon Cable TTL/5V CMOS compatibility
  - Opt UK6 Commercial Calibration Test Data with Certificate
  - 8766K, 8767K, 8768K, 8769K Coaxial Switches
- Specify RF connectors (and frequency), supply voltages, dc connectors by option number. Standard unit is 24 Vdc, 3.5-mm (f) RF connectors (dc to 26.5 GHz), and Viking-type dc connector.
- 8766K SP3T Multi-Port Switch
  - 8767K SP4T Multi-Port Switch
  - 8768K SP5T Multi-Port Switch
  - 8769K SP6T Multi-Port Switch
  - Opt 002 Replace 3.5 mm (f) w/ SMA (m) Connectors
  - Opt 008 8-inch Ribbon Cable w/DIP Connector
  - Opt 011 5 Vdc Supply Voltages
  - Opt 015 15 Vdc Supply Voltages
  - Opt 016 16-inch Ribbon Cable w/DIP Connector
  - Opt UK6 Commercial Calibration Test Data with Certificate

<sup>1</sup> Provides sensing capability with 87130A and 70611A

<sup>2</sup> 87406B only

<sup>3</sup> 87222C/E only

<sup>4</sup> Not available with 87204, 87206, or 87606 switches

 Indicates QuickShip availability.



### 87104/6 Series, 87204/6, 87222C/E, 87406B/606B, 8766/7/8/9 Series Specifications

Model	Frequency Range (GHz)	SWR (50 Ω Nominal)	Insertion Loss (dB)	Isolation (dB)	Switching Time (max)	Repeat-ability <sup>1</sup>	Life (min.)	RF Connectors	Dimensions W x H x D (mm)	Shipping Weight (g)
<b>87104A/204A SP4T</b>	dc to 4	<1.2 to 4 GHz	0.3 + .015 x f (GHz)	>100 to 4 GHz	15 ms	0.03 dB	5,000,000 cycles	SMA (f)	57 x 74 x 57	229
<b>87104B/204B SP4T</b>	dc to 20	<1.2 to 4 GHz <1.35 to 12.4 GHz <1.45 to 18 GHz <1.7 to 20 GHz	0.3 + .015 x f (GHz)	>100 to 12 GHz >70 at 20 GHz	15 ms	0.03 dB	5,000,000 cycles	SMA (f)	57 x 74 x 57	229
<b>87104C/204C SP4T</b>	dc to 26.5	<1.7 to 20 to 26.5 GHz	0.3 + .015 x f (GHz)	>65 to 20 to 26.5 GHz	15 ms	0.03 dB	5,000,000 cycles	SMA (f)	57 x 74 x 57	229
<b>87106A/206A SP6T</b>	dc to 4	<1.2 to 4 GHz	0.3 + .015 x f (GHz)	>100 to 4 GHz	15 ms	0.03 dB	5,000,000 cycles	SMA (f)	57 x 74 x 57	229
<b>87106B/206B SP6T</b>	dc to 20	<1.2 to 4 GHz <1.35 to 12.4 GHz <1.45 to 18 GHz <1.7 to 20 GHz	0.3 + .015 x f (GHz)	>100 to 12 GHz >70 at 20 GHz	15 ms	0.03 dB	5,000,000 cycles	SMA (f)	57 x 74 x 57	229
<b>87106C/206C SP6T</b>	dc to 26.5	<1.7 to 20 to 26.5 GHz	0.3 + .015 x f (GHz)	>65 to 20 to 26.5 GHz	15 ms	0.03 dB	5,000,000 cycles	SMA (f)	57 x 74 x 57	229
<b>87222C</b>	dc to 26.5	<1.1 to 2 GHz <1.15 to 4 GHz <1.25 to 12.4 GHz <1.4 to 20 GHz	0.2 + .025 x f (GHz)	>90 dB at 26.5 GHz	15 ms	0.03 dB	5,000,000 cycles	SMA (f)	32 x 69 x 32	100
<b>87222E</b>	dc to 50	<1.3 to 10 GHz <1.4 to 18 GHz <1.5 to 25 GHz <1.7 to 40 GHz <1.9 to 50 GHz	0.26 + .026 x f (GHz)	60 at 50 GHz	15 ms	0.03 dB	5,000,000 cycles	2.4 mm (f)	32 x 69 x 32	100
<b>87406B/606B</b>	dc to 20	<1.21 to 4 <1.35 to 10 <1.5 to 15 <1.7 to 18 <1.9 to 20	0.34 + 0.033 x f (GHz)	<100 to 12 GHz <80 to 15 GHz <70 to 20 GHz	15 ms	0.03	5,000,000 cycles	SMA (f)	57 x 74 x 57	229
<b>8766K SP3T</b>	dc to 26.5 or dc to 18 for Option 002	<1.3 to 8 GHz <1.5 to 12.4 GHz <1.6 to 18 GHz <1.8 to 26.5 GHz	Port 1: 0.2 dB + 0.05 dB/GHz Port 2: 0.2 dB + 0.06 dB/GHz	Consult Technical Data Sheet	20 ms	0.03 dB	5,000,000 cycles	3.5 mm (f)	45 x 23 x 82	178
<b>8767K SP4T</b>	dc to 26.5 or dc to 18 for Option 002	<1.3 to 8 GHz <1.5 to 12.4 GHz <1.6 to 18 GHz <1.8 to 26.5 GHz	Port 3: 0.2 dB + 0.08 dB/GHz Port 4: 0.25 dB + 0.095 dB/GHz		20 ms	0.03 dB	5,000,000 cycles	3.5 mm (f)	45 x 23 x 105	235
<b>8768K SP5T</b>	dc to 26.5 or dc to 18 for Option 002	<1.3 to 8 GHz <1.5 to 12.4 GHz <1.6 to 18 GHz <1.8 to 26.5 GHz	Port 5: 0.25 dB + 0.108 dB/GHz Port 6: 0.25 dB + 0.12 dB/GHz		20 ms	0.03 dB	5,000,000 cycles	3.5 mm (f)	45 x 23 x 133	292
<b>8769K SP6T</b>	dc to 26.5 or dc to 18 for Option 002	<1.3 to 8 GHz <1.55 to 12.4 GHz <1.8 to 18 GHz <2.05 to 26.5 GHz			20 ms	0.03 dB	5,000,000 cycles	3.5 mm (f)	45 x 23 x 160	349

<sup>1</sup>Measured at 25° C

For more information, visit our web site: <http://www.agilent.com/find/mta>

87104  
87106 Series  
87204  
87206 Series  
87222  
87406B  
87606B  
8766  
8767  
8768  
8769 Series

84904K  
84906K  
84907K  
84904L  
84906L  
84907L



84904/6/7K and L

### High-Performance Programmable Step Attenuators—dc to 40 GHz

- 84904K/L (0-11, dB steps)**
- 84906K/L (0-90, dB steps)**
- 84907K/L (0-70, dB steps)**

The 84904/906/907 family of programmable step attenuators offers unmatched attenuation performance to 40 GHz. The K model brings superior accuracy and reliability to 26.5 GHz, while the L model offers unparalleled performance to 40 GHz.

Agilent step attenuators consist of 3 or 4 cascaded sections of specific attenuation values, e.g., 1, 2, 4, 10, 20 and 40 dB. Both families offer the selection, performance, accuracy and reliability expected from HP attenuators: attenuation ranges of 11, 70, or 90 dB, 1 dB and 10 dB step sizes, 5 million cycles per section, better than 0.03 dB repeatability, connector size options and the choice of male or female connectors. RF connector choices include precision 3.5-mm or 2.92-mm on the 26.5 GHz K model, and precision 2.4-mm or 2.92-mm on the L model. While the 2.92-mm connector format is compatible with both 3.5-mm and SMA connectors, Agilent recommends the more rugged 2.4-mm and 3.5-mm connectors.

Programmable step attenuators feature electromechanical designs which achieve 20 milliseconds switching time, including settling time. The permanent magnet latching allows automatic interruption of the dc drive voltage to cut power consumption and simplify circuit design. They are equipped with 10-pin DIP sockets (m) with interconnect cables available.

### 84904/6/7K/L Specifications

Model	Frequency Range (GHz)	Attenuation Range	Maximum SWR Std (Option 006)	Insertion Loss 0 dB Setting	Repeatability <sup>1</sup>	Life <sup>2</sup>	Shipping Weight	Attenuation Accuracy	
								DC to 26.5 GHz	26.5 to 40 GHz
<b>84904K</b>	dc to 26.5	0 to 11 dB	1.3 (1.5) to 12.4 GHz	0.8 dB + 0.04 dB/GHz	0.03 dB	5 x 10 <sup>6</sup>	291 g (10.3 oz)	1 dB: 0.4 dB	1 dB: 0.6 dB
								2 dB: 0.5 dB	2 dB: 0.6 dB
								3 dB: 0.7 dB	3 dB: 0.8 dB
								4 dB: 0.7 dB	4 dB: 0.8 dB
<b>84906K</b>	dc to 26.5	0 to 90 dB	1.3 (1.5) to 12.4 GHz	0.8 dB + 0.04 dB/GHz	0.03 dB	5 x 10 <sup>6</sup>	291 g (10.3 oz)	5 dB: 0.7 dB	5 dB: 0.8 dB
								6 dB: 0.7 dB	6 dB: 0.9 dB
								7 dB: 0.8 dB	7 dB: 1.1 dB
								8 dB: 0.8 dB	8 dB: 1.1 dB
<b>84906L</b>	dc to 40	10 dB steps	1.7 (1.9) to 34 GHz	0.6 dB + 0.03 dB/GHz	0.03 dB	5 x 10 <sup>6</sup>	229 g (8.1 oz)	9 dB: 0.85 dB	9 dB: 1.2 dB
								10 dB: 0.9 dB	10 dB: 1.3 dB
								11 dB: 1.0 dB	11 dB: 1.5 dB
								10 dB: 0.5 dB	10 dB: 0.5 dB
<b>84907K</b>	dc to 26.5	0 to 70 dB	1.25 (1.4) to 12.4 GHz	0.6 dB + 0.03 dB/GHz	0.03 dB	5 x 10 <sup>6</sup>	229 g (8.1 oz)	20 dB: 0.6 dB	20 dB: 0.6 dB
								30 dB: 0.7 dB	30 dB: 0.7 dB
								40 dB: 1.0 dB	40 dB: 1.0 dB
								50 dB: 1.2 dB	50 dB: 1.2 dB
<b>84907L</b>	dc to 40	10 dB steps	1.5 (1.7) to 34 GHz	0.6 dB + 0.03 dB/GHz	0.03 dB	5 x 10 <sup>6</sup>	229 g (8.1 oz)	60 dB: 1.6 dB	60 dB: 1.6 dB
								70 dB: 1.9 dB	70 dB: 1.9 dB
								80 dB: 2.7 dB	80 dB: 2.7 dB
								90 dB: 2.9 dB	90 dB: 2.9 dB

**Sensitivity power:** dB/watt (temperature dB/°C): 0.001 (0.0001)  
**Power rating:** 1 W ave, 50 W peak, 10 μs max. pulse width  
**Supply voltage/speed/power:** 20 to 30 V / <20 ms / 2.7 W

<sup>1</sup> Measured at 25° C  
<sup>2</sup> Cycles per section minimum

### Programmable Driver Instruments

Drive options include the 11713A and 87130A attenuator/switch drivers, which permit users to easily integrate the attenuator into GPIB compatible automatic test systems, and the 70611 MMS attenuator/switch driver. Cabling options include 8- or 16-inch ribbon cables (11764C/D) with a 10-pin DIP socket (f) and a 14-pin DIP plug for easy connection to standard 14-pin DIP IC sockets, a 5-foot Interconnect Cable (11764A) with 10-pin DIP socket (f), and a “Viking” connector for the 11713A driver, and a 5-foot Interconnect Cable (11764B) with a 10-pin DIP socket (f) and bare leads for custom applications. Option 100 series replaces one female connector with a male connector to allow end-to-end connection of 1 dB and 10 dB step attenuators.

### Key Literature

Latest RF & Microwave Test Accessories Catalog, p/n 5968-4314E

For more information, visit our web site: <http://www.agilent.com/find/mta>

### Ordering Information

#### Attenuators

- 84904K** 0 to 11 dB, 1 dB steps, 26.5 GHz
- 84904L** 0 to 11 dB, 1 dB steps, 40 GHz
- 84906K** 0 to 90 dB, 10 dB steps, 26.5 GHz
- 84906L** 0 to 90 dB, 10 dB steps, 40 GHz
- 84907K** 0 to 70 dB, 10 dB steps, 26.5 GHz
- 84907L** 0 to 70 dB, 10 dB steps, 40 GHz
- Opt 006** Female 2.92-mm Connectors (L models only)
- Opt 011** 5 Vdc Supply Voltage
- Opt 015** 15 Vdc Supply Voltage
- Opt 100** Male 2.4-mm Connector (L models only)
- Opt 104** Male 3.5-mm Connector (K models only)
- Opt 106** Male 2.92-mm Connector (L models only)
- Opt UK6** Commercial Calibration Test Data with Certificate





8495D

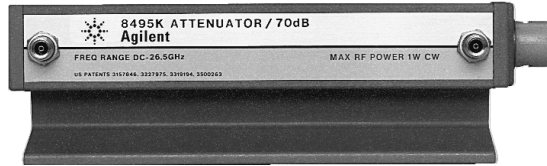

8495K

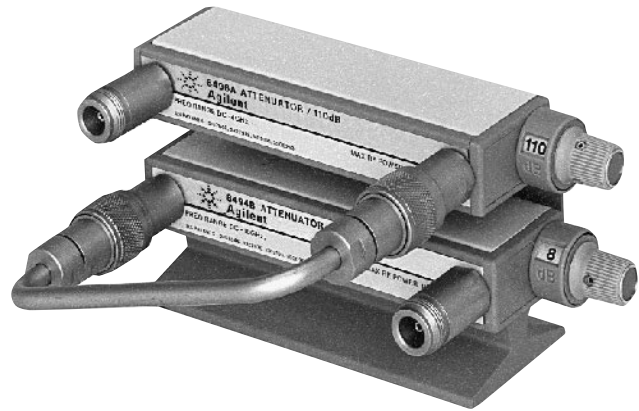

11716A

355 Series  
8494  
8495  
8496  
8497 Series  
11716 Series

### Programmable and Manual Step Attenuators DC–1000 MHz

#### Manual

**355C** (0–12 dB, 1 dB steps)  
**355D** (0–120 dB, 10 dB steps)

#### Programmable

**355E** (0–12 dB, 1 dB steps)  
**355F** (0–120 dB, 10 dB steps)

The manual and programmable 355 C/D/E/F attenuators offer exceptional attenuation accuracy to 1 GHz; +0.1 dB to 1 kHz, 0.25 dB to 500 MHz, 0.35 to 1 GHz. They feature BNC (f) RF connectors, with optional type-N (Option 001) and TNC (Option 005) also available. To achieve 1 dB steps to 132 dB range, serially connect two attenuators using a standard UG-491A/U BNC (m)-to-BNC (m) adapter. Programmable 355 E/F models feature a 7-pin connector (supplied). To protect your transistor driver against transients during the switching cycle, order Option 007 to install a protective diode between each solenoid and driver.

### Programmable and Manual Step Attenuators DC–26.5 GHz

**8494A/B/G/H** (0–11 dB, 1 dB steps)  
**8495A/B/D/G/H/K** (0–70 dB, 10 dB steps)  
**8496A/B/G/H** (0–110 dB, 10 dB steps)  
**8497K** (0–90 dB, 10 dB steps)

The 8494/95/96/97 family of step attenuators offer fast, precise signal level control in three frequency ranges, dc to 4 GHz, dc to 18 GHz and dc to 26.5 GHz. They feature exceptional repeatability and reliability in a wide range of frequency, attenuation and connector options.

Attenuation repeatability is specified to be less than 0.03 dB (0.05 dB, 18–26.5 GHz) for 5 million cycles per section. This assures low measurement uncertainty and high user confidence when designed into automatic test systems. Electromechanical step attenuators offer low SWR, low insertion loss and high accuracy required by high-performance test and measurement equipment.

Precision plated leaf-spring contacts remove attenuator sections (miniature tantalum nitride thin-film T-pads on sapphire and alumina substrates) from the signal path. Unique process controls and material selection ensure unmatched life and contact repeatability.

### Programmable Models

Miniature drive solenoids in the programmable models keep switching time, including settling, down to less than 20 milliseconds. Once switched, strong permanent magnets hold the solenoids (and attenuation value) in place. Current interrupts automatically disconnect solenoid current, simplifying driver circuit design and minimizing heat dissipation. Programming is done through a 12-pin Viking socket or optional ribbon cables with DIP plugs.

To simplify connecting programmable attenuators to the drive circuit, each unit is supplied with a 5-ft. cable assembly. With an 11713A attenuator driver, 87130A attenuator driver, or an 70611A driver for MMS-based systems, automatic drive control is easy using the Agilent Technologies Interface Bus (GPIB) automated system.

### 11716A/C Attenuator Interconnect Kits

Quickly and conveniently connect 1 dB step and 10 dB step attenuators together to achieve greater dynamic range with 1 dB steps. The 11716A/C interconnect kits contain a rigid RF cable, mounting bracket, and necessary hardware to connect any pair of 8494/95/96/97 attenuators in series (see photo above). Attenuators must be ordered separately.

### Key Literature

Latest RF & Microwave Test Accessories Catalog, p/n 5968-4314E

For more information, visit our web site: <http://www.agilent.com/find/mta>

### Ordering Information

**11716A** Interconnect Kit (Type-N)  
**11716C** Interconnect Kit (SMA)



Indicates QuickShip availability.

### 355 Series, 8494/5/6/7 Series Specifications

Model (Switching Mode)	Frequency Range (GHz)	Attenuation Range (dB)	Maximum SWR	Insertion Loss @ 0 dB	Attenuation Accuracy	Power Rating, Minimum Life	Solenoid Voltage Speed Power	Size, Shipping Weight	Connector Options
<b>355C (Manual)</b>	dc to 1	0 to 12 1 dB steps	1.2 to 250 MHz 1.3 to 500 MHz 1.5 to 1 GHz	0.11 dB + 1.39 dB/GHz	±0.1 dB @ 1000 Hz ±0.25 dB: dc to 0.5 GHz ±0.35 dB: dc to 1.0 GHz	0.5 W avg. 350 W peak 0.5 million cycles per section	— 15 to 18 V <65 ms 3.0 W	70 mm W x 67 mm H x 152 mm D (2.75 in x 2.6 in x 6 in) 1.4 kg (3 lb)	BNC (f) See Note 1
<b>355E (Programmable)</b>									
<b>355D (Manual)</b>	dc to 1	0 to 120 10 dB steps	1.2 to 0.25 GHz 1.3 to 0.5 GHz 1.5 to 1 GHz	0.11 dB + 1.39 dB/GHz	±0.3 dB @ 1000 Hz ±1.5 dB to 90 dB, and ±3 dB to 120 dB @ 1 GHz	0.5 W avg. 350 W peak 0.5 million cycles per section	— 15 to 18 V <65 ms 3.0 W	70 mm W x 67 mm H x 152 mm D (2.75 in x 2.6 in x 6 in) 1.4 kg (3 lb)	BNC (f) See Note 1
<b>355F (Programmable)</b>									
<b>8494A (Manual)</b>	dc to 4	0 to 11 1 dB steps	1.5	0.6 dB + 0.09 dB/GHz	±0.2 dB: 1 to 2 dB ±0.3 dB: 3 to 6 dB ±0.4 dB: 7 to 10 dB ±0.5 dB: 11 dB	1 W avg. 100 W peak 10 µs max. 5 million cycles per section	— 20 to 30 V <20 ms 2.7 W	73 mm W x 43 mm H x 159 mm D (2.9 in x 1.7 in x 6.2 in) 0.9 kg (2 lb) 79 mm W x 43 mm H x 168 mm D (3.1 in x 1.7 in x 6.6 in) 0.9 kg (2 lb)	001 002 003 See Note 2
<b>8494G (Programmable)</b>									
<b>8494B (Manual)</b>	dc to 18	0 to 11 1 dB steps	1.5 to 8 GHz 1.6 to 12.4 GHz 1.9 to 18 GHz	0.6 dB + 0.09 dB/GHz	<b>dc to 12.4 GHz</b> ±0.3 dB: 1 to 2 dB ±0.4 dB: 3 to 4 dB ±0.5 dB: 5 to 6 dB ±0.6 dB: 7 to 10 dB ±0.7 dB: 11 dB <b>dc to 18 GHz</b> ±0.7 dB: 1 to 5 dB ±0.8 dB: 6 to 9 dB ±0.9 dB: 10 to 11 dB	1 W avg. 100 W peak 10 µs max. 5 million cycles per section	— 20 to 30 V <20 ms 2.7 W	73 mm W x 43 mm H x 159 mm D (2.9 in x 1.7 in x 6.2 in) 0.9 kg (2 lb) 79 mm W x 43 mm H x 168 mm D (3.1 in x 1.7 in x 6.6 in) 0.9 kg (2 lb)	001 002 003 See Note 2
<b>8494H (Programmable)</b>									
<b>8495A (Manual)</b>	dc to 4	0 to 70 10 dB steps	1.35	0.4 dB + 0.07 dB/GHz	±1.7 dB of setting or 0.4 dB, whichever is greater	1 W avg. 100 W peak 10 µs max. 5 million cycles per section	— 20 to 30 V <20 ms 2.7 W	73 mm W x 43 mm H x 130 mm D (2.9 in x 1.7 in x 5.1 in) 0.9 kg (2 lb) 79 mm W x 43 mm H x 141 mm D (3.1 in x 1.7 in x 5.5 in) 0.9 kg (2 lb)	001 002 003 See Note 2
<b>8495G (Programmable)</b>									
<b>8495B (Manual)</b>	dc to 18	0 to 70 10 dB steps	1.35 to 8 GHz 1.5 to 12.4 GHz 1.7 to 18 GHz	0.4 dB + 0.07 dB/GHz	±3 dB: dc to 12.4 GHz ±4 dB: dc to 18 GHz	1 W avg. 100 W peak 10 µs max. 5 million cycles per section	— 20 to 30 V <20 ms 2.7 W	73 mm W x 43 mm H x 130 mm D (2.9 in x 1.7 in x 5.1 in) 0.9 kg (2 lb) 79 mm W x 43 mm H x 141 mm D (3.1 in x 1.7 in x 5.5 in) 0.9 kg (2 lb)	001 002 003 See Note 2
<b>8495H (Programmable)</b>									
<b>8495D (Manual)</b>	dc to 26.5	0 to 70 10 dB steps	1.25 to 6 GHz 1.45 to 12.4 GHz 1.6 to 18.0 GHz 1.8 to 26.5 GHz	0.5 dB + 0.13 dB/GHz	±0.3 dB at 6 GHz 10 dB attenuation to ±2.8 dB at 26.5 GHz 90 dB attenuation	1 W avg. 100 W peak 10 µs max. 5 million cycles per section	— 20 to 30 V <20 ms 2.7 W	52 mm W x 43 mm H x 159 mm D (2.1 in x 1.7 in x 6.2 in) 0.9 kg (2 lb) 52 mm W x 43 mm H x 168 mm D (2.1 in x 1.7 in x 6.6 in) 0.9 kg (2 lb)	004 3.5 mm See Note 2
<b>8495K (Programmable)</b>									
<b>8496A (Manual)</b>	dc to 4	0 to 110 10 dB steps	1.5	0.6 dB + 0.09 dB/GHz	±1.7 dB of setting or 0.4 dB, whichever is greater	1 W avg. 100 W peak 10 µs max. 5 million cycles per section	— 20 to 30 V <20 ms 2.7 W	73 mm W x 43 mm H x 159 mm D (2.9 in x 1.7 in x 6.2 in) 0.9 kg (2 lb) 79 mm W x 43 mm H x 168 mm D (3.1 in x 1.7 in x 6.6 in) 0.9 kg (2 lb)	001 002 003 See Note 2
<b>8496G (Programmable)</b>									
<b>8496B (Manual)</b>	dc to 18	0 to 110 10 dB steps	1.5 to 8 GHz 1.6 to 12.4 GHz 1.9 to 18 GHz	0.6 dB + 0.09 dB/GHz	±3 dB: dc to 12.4 GHz ±4 dB: dc to 18 GHz	1 W avg. 100 W peak 10 µs max. 5 million cycles per section	— 20 to 30 V <20 ms 2.7 W	73 mm W x 43 mm H x 159 mm D (2.9 in x 1.7 in x 6.2 in) 0.9 kg (2 lb) 79 mm W x 43 mm H x 168 mm D (3.1 in x 1.7 in x 6.6 in) 0.9 kg (2 lb)	001 002 003 See Note 2
<b>8496H (Programmable)</b>									
<b>8497K (Programmable)</b>	dc to 26.5	0 to 90 10 dB steps	1.25 to 6 GHz 1.45 to 12.4 GHz 1.6 to 18.0 GHz 1.8 to 26.5 GHz	0.4 dB + 0.09 dB/GHz	±0.3 dB at 6 GHz 10 dB attenuation to ±2.8 dB at 26.5 GHz 90 dB attenuation	1 W avg. 100 W peak 10 µs max. 5 million cycles per section	5 V or 24 V	52 mm W x 43 mm H x 143 mm D (2.1 in x 1.7 in x 5.6 in) 0.9 kg (2 lb)	004 3.5 mm See Note 2

### How to Order the 8494/5/6/7 Series Attenuators

Each order must include basic model number, suffix letter, and connector option.

**Ordering example: 8494A Option 001**

4	A	001
4 (1 dB step, 11 dB max)	A (Manual, dc to 4 GHz)	001 (N female)
5 (10 dB step, 70 dB max)	B (Manual, dc to 18 GHz)	002 (SMA female)
6 (10 dB step, 110 dB max)	D (Manual, dc to 26.5 GHz)*	003 (APC-7)
7 (10 dB step, 90 dB max)	G (Programmable, dc to 4 GHz)	004 (3.5 mm female) <sup>1</sup>
	H (Programmable, dc to 18 GHz)	
	K (Programmable, dc to 26.5 GHz)*	

<sup>1</sup>Option 004 is only available on D and K models.

**Note 1:** 355C/D/E/F connector options (BNC (f) standard):

- Option 001 N(f)
- Option 005 TNC(f)
- Option 007 Transistor protection (355E/F only)

**Note 2:** 8494/5/6/7 orders must specify connector option. See ordering example.

- Option 001 N(f)
- Option 002 SMA(f)
- Option 003 APC-7
- Option 004 3.5 mm (8495D/K, 8497K only)
- Option UK6 Commercial Calibration Test Data with Certificate

 Indicates QuickShip availability.



8490D

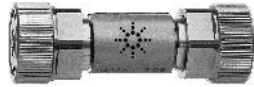

8492A



8493A/B/C Series

### 8491A/B, 8492A, 8493A/B/C Fixed Attenuators

Agilent coaxial fixed attenuators provide precise attenuation, flat frequency response, and low SWR over broad frequency ranges. Attenuators are available in nominal attenuations of 3 dB and 6 dB, as well as 10 dB increments from 10 dB to 60 dB. These attenuators are swept-frequency tested to ensure they meet specifications at all frequencies. Calibration points are provided on a nameplate chart attached to each unit.

### 8498A High Power Attenuator

The 8498A Option 030 is designed to meet the needs of high-power attenuation applications in the RF and microwave frequency range. It is a 25-watt average, 30 dB fixed attenuator with a frequency of dc to 18 GHz. The maximum peak power specification is 500 watts (dc to 5.8 GHz) and 125 watts (5.8 to 18 GHz). Available only in a 30 dB version, the unit offers a 1.3 SWR and  $\pm 1$  dB accuracy at 18 GHz. Large heat-dissipating fins keep the unit cool even under continuous maximum input power conditions.

### 8490D 50-GHz Fixed Attenuator

Agilent coaxial fixed attenuators have been the standard for accurate flat response and low SWR. The 8490D offers exceptional performance to 50 GHz using the 2.4-mm connector. Attenuation values available are 3, 6, 10, 20, 30 and 40 dB. Ideally suited for extending the range of sensitive power meters, or for use as calibration standards, these broadband attenuators are manufactured with the same meticulous care as their lower frequency counterparts.

### 8490D, 8491A/B/C, 8492A, 8493A/B/C, 8498A, Specifications

Model	Frequency range (GHz)	SWR (max.)	Input Power (max.)	Attenuation Accuracy (+dB)									Connectors			
				3 dB Opt 003	6 dB Opt 006	10 dB Opt 010	20 dB Opt 020	30 dB Opt 030	40 dB Opt 040	50 dB Opt 050	60 dB Opt 060					
8490D	DC to 50	dc to 26.5 GHz: 1.15 (1.08 Opt 040 only) 26.5 to 40 GHz: 1.25 (1.15 Opt 040 only) 40 to 50 GHz: 1.45 (1.25 Opt 040 only)	2 W avg. 100 W peak	DC to 26.5	+0.9	+0.9	+0.9	+1.3	+1.3	+2.5						
				26.5 to 50	-0.5	-0.6	-0.6	-0.8	-0.8	-1.8						
8491A	3 to 30 dB 40 to 60 dB	1.2 to 8 GHz 1.3 to 12.4 GHz	2 W avg. 100 W peak		0.3	0.3	0.5	0.5	1.0	1.5	1.5	2		2.4 mm	N (m,f)	
8491B	3 to 30 dB 40 to 60 dB	1.2 to 8 GHz 1.3 to 12.4 GHz 1.5 to 18 GHz	2 W avg. 100 W peak		0.3	0.3 to 12.4 GHz 0.4 to 18 GHz	0.6	0.6 to 12.4 GHz 1.0 to 18 GHz	1.0	1.5	1.5	2			N (m,f)	
8492A	3 to 30 dB 40 to 60 dB	1.15 to 8 GHz 1.25 to 12.4 GHz 1.35 to 18 GHz	2 W avg. 100 W peak		0.3	0.3 to 12.4 GHz 0.4 to 18 GHz	0.6	0.6 to 12.4 GHz 1.0 to 18 GHz	1.0	1.5	1.5	2			APC-7	
8493A	3 to 20 dB 30 dB	1.2 to 8 GHz 1.3 to 12.4 GHz	2 W avg. 100 W peak		0.3	0.3	0.5	0.5	1.0	—	—	—			SMA (m,f)	
8493B	3 to 20 dB 30 dB	1.2 to 8 GHz 1.3 to 12.4 GHz 1.5 to 18 GHz	2 W avg. 100 W peak		+0.3 dB	0.3 to 12.4 GHz 0.4 to 18 GHz	0.6	0.6 to 12.4 GHz 1.0 to 18 GHz	1.0	—	—	—			SMA (m,f)	
8493C	3 to 30 dB 40 dB	1.1 to 8 GHz 1.15 to 12.4 GHz 1.25 to 26.5 GHz	2 W avg. 100 W peak		0.5 to 18 GHz 1.0 to 26.5 GHz	0.6	0.3	0.5	0.7	1.0	—	—			3.5 mm (m,f)	
8498A	30 dB	1.15 to 8 GHz 1.25 to 12.4 GHz 1.35 to 18 GHz	25 W avg. 500 W peak (dc to 5.8 GHz) 125 W peak 500 W/ms max. per puls (5.8 to 18 GHz)		—	—	—	—	1.0	—	—	—			N (m,f)	

Models	Options UK6
8491A, 8491B, 8492A, 8493A, 8493B, 8493C, 8498A	Opt UK6-Commercial Calibration Test Data with Certificate

### 11581A, 11582A, 11583C Attenuator Sets

A set of four Agilent attenuators—3, 6, 10, and 20 dB—are furnished in a handsome walnut accessory case. The 11581A set consists of 8491A attenuators; the 11582A set, 8491B attenuators; 8492A attenuators; and the 11583C set, 8493C attenuators. These sets are ideal for calibration labs or where precise knowledge of attenuation and SWR is desired. Also includes commercial calibration certificate with test data.

### Key Literature

Latest RF & Microwave Test Accessories Catalog, p/n 5968-4314E

For more information, visit our web site: <http://www.agilent.com/find/mta>

### Ordering Information

11581A 3, 6, 10, 20 dB 8491A Set

11582A 3, 6, 10, 20 dB 8491B Set

11583C 3, 6, 10, 20 dB 8493C Set

Opt 910 Extra Operating and Service Manual

8490D  
8491 Series  
8492A  
8493 Series  
8498A  
11581A  
11582A  
11583A  
11583C

423B  
8470 Series  
83036C



8474 Series



8471D/E



83036C

## Low-Barrier Schottky Diode Detectors

### 423B, 8472B, 8473B/C

These Low-Barrier Schottky Diode (LBSD) detectors have been widely used for many years in a variety of applications including leveling and power sensing. They offer good performance and ruggedness. Matched pairs (Option 001) offer very good detector tracking. A video load option (Option 002) extends the square-law region to at least 0.1 mW(-10 dBm).

## Planar-Doped Barrier Detectors

### 8471D/E

The 8471D/E are economy detectors based on the Planar-Doped Barrier (PDB) diodes. The PDB diodes give them superior frequency response, square-law response, and temperature performance. The 8471D has a BNC (m) input connector and a frequency range of 100 kHz to 2 GHz, making it ideal for use in RF and low microwave applications. The 8471E has a SMA (m) input connector and a SMC (m) output connector. Its frequency range is 10 MHz to 12 GHz. Both models come standard with a negative polarity output; a positive polarity output can be specified as Option 103.

### 8473D

The 8473D detector was the first gallium arsenide PDB diode introduced. It features broadband performance and excellent flatness vs. frequency, along with superior temperature stability. The 8473D is available with a 3.5-mm (m) RF connector and a BNC (f) output connector.

## High-Performance Planar-Doped Barrier Detectors

### 8474B/C/D/E

Utilizing a gallium arsenide PDB diode as the detecting element, these detectors offer superior performance when compared to earlier detector designs. They feature extremely flat frequency response over their entire band of operation (typically better than  $\pm 1$  dB to 50 GHz) and very good frequency response stability versus temperature. For applications where broadband frequency coverage is not required, octave band options are available in specific bands.

The 8474 detectors are available with APC-7 (0.01 to 18 GHz), Type N (0.01 to 18 GHz), 3.5 mm (mates with SMA, 0.01 to 33 GHz), 2.92 mm (0.01 to 40 GHz), or 2.4 mm (0.01 to 50 GHz) connectors. These detectors are offered with options for optimal square-law loads (Option 102) and for positive polarity output (Option 103). Because the unit-to-unit frequency response tracking of these devices is typically better than  $\pm 0.3$  dB, no matched response option is offered.

## Broadband Directional Detector

### 83036C

The 83036C is a broadband microwave power sampler that operates in much the same way as a directional coupler and detector combination. It is composed of a resistive bridge and PDB diode that yields a very broadband device with excellent frequency response, superior temperature response and square-law response characteristics. With a 10 MHz to 26.5 GHz frequency range, a single 83036C can be used in many applications where two directional couplers and detectors were once required, such as in broadband power monitoring and source leveling.

The maximum SWR is 1.7 above 50 MHz on both the input and output ports. Directivity of 14 dB matches that of most miniature couplers currently available. The maximum insertion loss is 2.2 dB.

The 83036C has been used with great success as the sampling element for external leveling of broadband swept frequency sources. The extended frequency range increases the usable band from 100 MHz to 26 GHz, giving the user full use of the broadband source with external leveling. Other uses include the internal leveling element for sources, and forward/reverse power monitoring.

## Key Literature

Latest RF & Microwave Test Accessories Catalog, p/n 5968-4314E

For more information, visit our web site: <http://www.agilent.com/find/mta>



### Planar-Doped Barrier Diode Detectors Specifications

Model	Freq. Range (GHz)	Freq. Response (dB)	Max. SWR	Low-level Sensitivity	Max. Input (Peak or Average)	Short-term Max. Input (<1 min.)	Opt. 002/102 Optimum Square-Law Load	Opt. 003/103 Positive Polarity Output	Input/Output Connector
8471D	0.0001 to 2	±0.2 to 1 GHz ±0.4 to 2 GHz	1.23 to 1 GHz 1.46 to 2 GHz	>0.5 mV/μW	100 mW	0.7 W	Yes	Yes	BNC (m) BNC (f)
8471E	0.01 to 12	±0.23 to 4 GHz ±0.6 to 8 GHz ±0.85 to 12 GHz	1.2 to 4 GHz 1.7 to 8 GHz 2.4 to 12 GHz	>0.4 mV/μW	200 mW	0.75 W	No	Yes	SMA (m) SMC (m)
8473D	0.01 to 33	±0.25 to 12.4 GHz ±0.40 to 26.5 GHz ±1.25 to 33 GHz	1.2 to 14 GHz 1.36 to 26.5 GHz 2.96 to 33 GHz	>0.4 mV/μW	200 mW	1 W	Note 1	Note 1	3.5 mm (m) BNC (f)
8474B <sup>1</sup>	0.01 to 18	±0.35 to 18 GHz	1.3 to 18 GHz	>0.4 mV/μW	200 mW	.75 W	Note 1	Note 1	Type N (m) BNC (f)
8474C <sup>1</sup>	0.01 to 33	±0.45 to 26.5 GHz ±0.70 to 33 GHz	1.4 to 26.5 GHz 2.2 to 33 GHz	>0.4 mV/μW	200 mW	.75 W	No	Note 1	3.5 mm (m) SMC (m)
8474E <sup>1</sup>	0.01 to 50	±0.4 to 26.5 GHz ±0.6 to 40 GHz ±1.0 to 50 GHz	1.2 to 26.5 GHz 1.6 to 40 GHz 2.8 to 50 GHz	>0.4 mV/μW	200 mW	.75 W	No	Note 1	2.4 mm (m) SMC (m)

<sup>1</sup>Octave band options available (see Data Sheet).

### Broadband Directional Detector Specifications

Model	Freq. Range (GHz)	Freq. Response (dB)	Max. SWR Input/Output (50 Ω Nom.)	Max. Thru Line Loss (dB)	Low-level Sensitivity	Min. Directivity (dB)	Max. Input (Into 50 Ω Load) w/ 2:1 Source Match	Max. Input (Into Open) w/ 2:1 Source Match	Input/Output Connector
83036C	0.01 to 26.5	±1.0	1.7	2.2	18 mV/μW	14	32 dBm	21 dBm	3.5 mm (f)

### Low-Barrier Schottky Diode Detectors Specifications

Model	Freq. Range (GHz)	Freq. Response (dB)	Max. SWR (50 Ω Nom.)	Low-level Sensitivity (mV/μW)	Max. Input (Peak or Average)	Short-term Max. Input (<1 min.)	Matched <sup>2</sup> Response Opt. 001	Optimum Square-law Load <sup>3</sup>	Positive Polarity Output	Input/Output Connector
423B	0.01 to 12.4	±0.3 to 12.4 GHz	1.15 to 4 GHz 1.3 to 12.4 GHz	>0.5	200 mW	1 W (typical)	±0.2 dB to 12.4 GHz	Opt. 002	Opt. 003	N (m) BNC (f)
8470B 8470B Option 012	0.01 to 18	±0.3 to 12.4 GHz ±0.5 to 15 GHz ±0.6 to 18 GHz	1.15 to 4 GHz 1.3 to 15 GHz 1.4 to 18 GHz	>0.5	200 mW	1 W (typical)	±0.2 dB to 12.4 GHz ±0.3 to 18 GHz	Opt. 002	Opt. 003	APC-7 BNC (f) N (m) BNC (f)
8472B Option 100	0.01 to 18	±0.3 to 12.4 GHz ±0.5 to 15 GHz ±0.6 to 18 GHz	1.15 to 4.5 GHz 1.35 to 7 GHz 1.5 to 12.4 GHz 1.7 to 18 GHz	>0.5	200 mW	1 W (typical)	±0.2 dB to 12.4 GHz ±0.3 to 18 GHz	Opt. 002	Opt. 003	SMA (m) BNC (f) SMA (m) OSSM (f)
8473B	0.01 to 18	±0.3 to 12.4 GHz ±0.6 to 18 GHz	1.2 to 4 GHz 1.5 to 18 GHz	>0.5	200 mW	1 W (typical)	±0.2 dB to 12.4 GHz ±0.3 to 18 GHz	Opt. 002	Opt. 003	3.5 mm (m) BNC (f)
8473C	0.01 to 26.5	±0.3 to 12.4 GHz ±0.6 to 20 GHz ±1.5 to 26.5 GHz	1.2 to 4 GHz 1.5 to 18 GHz 2.2 to 26.5 GHz	>0.5	200 mW	1 W (typical)	±0.2 dB to 12.4 GHz ±0.3 to 18 GHz ±0.5 to 26.5 GHz	Opt. 002	Opt. 003	3.5 mm (m) BNC (f)

<sup>1</sup>Available as a special option on request. Consult your Agilent Technologies representative.

<sup>2</sup>Must order a quantity of 2 standards and 2 Option 001s for a pair of detectors with matched frequency response.

<sup>3</sup>Defined as ± 0.5 from ideal square law response.

 Indicates QuickShip availability.

For more information, visit our web site: <http://www.agilent.com/find/mta>

770 Series  
11691D  
11692D  
87300  
Series

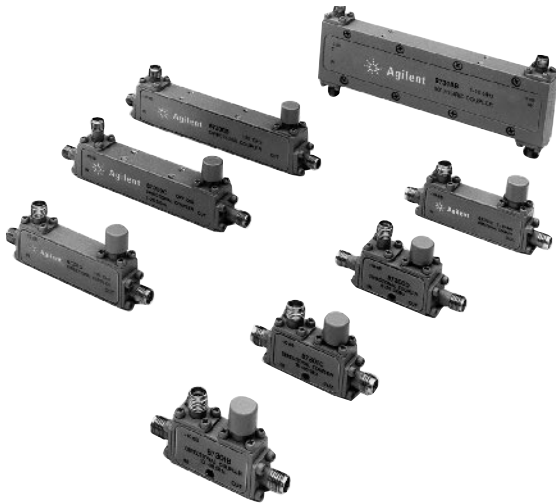

87300B/C/D, 87301B/C/D, 87310B, 87301E

### 87300 Series Directional Couplers

This line of compact, broadband directional couplers is ideal for signal monitoring, or when combined with a coaxial detector, for signal leveling. Available in a variety of frequency ranges, they can be matched to specific applications. The Agilent 8474 series coaxial detectors are recommended if output detection is desired. The 87300B is supplied with SMA (f) connectors, the 87300C has 3.5-mm (f) connectors, and the 87301D has 2.4-mm (f) standard or optional 2.92-mm (f) connectors.

### 87310B Hybrid Coupler

87310B is a 3 dB hybrid coupler, intended for applications requiring a 90 degree phase difference between output ports. In that sense, it is different from typical power dividers and power splitters, which have matched signal phase at their output ports. The 87310B features SMA (f) connectors.

### 87300 Series Specifications

Model	Freq. Range (GHz)	Nominal Coupling & (dB) Variation	Directivity (dB)	Max. SWR	Insertion Loss (dB)
87300B	1 to 20	10 ± 0.5	16	1.35	<1.5
87300C	1 to 26.5	10 ± 1	>14 to 12.4 GHz >12 to 26.5 GHz	1.40	<1.2 to 12.4 <1.7 to 26.5
87300C Opt 020	1 to 26.5	20 ± 1	>14	1.4	<1.2
87300D	6 to 26.5	10 ± 0.5	>13	1.4	<1.3
87301B	10 to 46	10 ± 0.7	>10	1.8	<1.9
87301C	10 to 50	10 ± 0.7	>10	1.8	<1.9
87301D	1 to 40	13 ± 1	>14 to 20 >10 to 40	1.5 to 20 1.7 to 40	<1.2 to 20 <1.9 to 40
87310B	1 to 18	3 ± 0.5	—	1.35	<2.0
87301E	2 to 50	10 ± 1	>13 to 26.5 >10 to 50	1.5 to 26.5 1.8 to 50	<2.0

### 773D Directional Coupler and 772D Dual-Directional Coupler

The 772D and 773D are high-performance couplers designed for broadband swept measurements in the 2 to 18 GHz range. The 773D is ideal for leveling broadband sources when used with an 8474B detector. (See also the 83036C directional detector.) For reflectometer applications, the 772D is the best coupler to use with power sensors and power meters (such as the 438A dual power meter). Forward and reverse power measurements on transmitters, components or other broadband systems are made simpler using the 772D. The broadband design allows the use of a single test setup and calibration for tests spanning the entire 2 to 18 GHz frequency range.

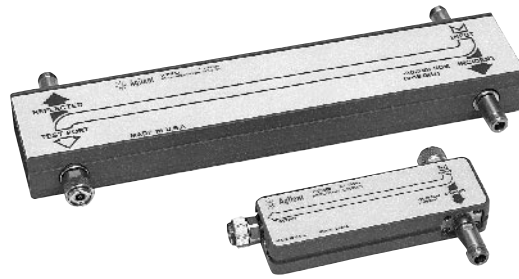

772D and 773D

### 775D to 779D Dual-Directional Couplers

The economical 775D-778D couplers cover octave frequency spreads of more than 2:1, each centered on one of the important VHF/UHF bands. With their high directivity and mean coupling accuracy of ±0.5 dB, these are ideal couplers in reflectometer applications. The close tracking of the auxiliary arms makes these couplers particularly useful for reflectometers. Power ratings are 50 W average, 500 W peak.

### 772-779D, 11691D, 11692D Specifications

Model	Freq. Range (GHz)	Nominal Coupling (dB)	Max. Coupling Variation (dB)	Min. Directivity	SWR Primary Line Max. (50 Ω Nom.)
772D	2 to 18	20	±0.9	2 to 12.4: 30 12.4 to 18: 27	2 to 12.4: 1.3 12.4 to 18: 1.4
773D	2 to 18	20	±0.9	2 to 12.4: 30 12.4 to 18: 27	1.3 1.4
775D <sup>1</sup>	0.45 to 0.94	20	±1	40	1.15
776D <sup>1</sup>	0.94 to 1.9	20	±1	40	1.15
777D	1.9 to 4	20	±0.4	30	1.2
778D	0.1 to 2	20	±1.5	0.1 to 1 GHz: 36 <sup>2</sup> 1 to 2 GHz: 32 <sup>2</sup>	1.1
779D	1.7 to 12.4	20	±0.75	1.7 to 4 GHz: 30 4 to 12.4 GHz: 26	1.2
11691D	2 to 18	20	±1.0	2 to 8 GHz: 30 <sup>3</sup> 8 to 18 GHz: 26 <sup>3</sup>	1.3 1.4
11692D	2 to 18	20	±1 incident to test port	2 to 8 GHz: 30 <sup>3</sup> 8 to 18 GHz: 26 <sup>3</sup>	2 to 12.4 GHz: 1.3 12.4 to 18 GHz: 1.4

<sup>1</sup>Maximum auxiliary arm tracking: 0.3 dB for 776D; 0.5 dB for 777D

<sup>2</sup>30 dB, 0.1 to 2 GHz, input port

<sup>3</sup>24 dB with Type-N connector on the test port (11692D) or on the input port (11691D)

### Key Literature

Latest RF & Microwave Test Accessories Catalog, p/n 5968-4314E

### 87302C, 87303C, and 87304C Hybrid Power Dividers

The 87302C, 87303C, and 87304C power dividers are compact, hybrid microwave couplers designed for power splitting applications that require minimal insertion loss and high isolation.

The 87302C covers the entire 0.5 to 26.5 GHz frequency range with a maximum insertion loss of 1.9 dB. The 87303C and 87304C cover the frequency range of 1 to 26.5 GHz and 2 to 26.5 GHz with an even lower insertion loss of 1.6 dB and 1.4 dB, respectively. These hybrid power dividers are excellent for any application requiring low loss power division. They typically exhibit an insertion loss that is 1 to 2 dB lower than an equivalent resistive power divider.

Model	Freq. Range (GHz)	Band Segments	Insertion Loss (dB)	Isolation (dB)
87302C	0.5 to 26.5	0.5 to 18 GHz 18 to 26 GHz	1.5 1.9	19 19
87303C	1.0 to 26.5	1.0 to 18 GHz 18 to 26.5 GHz	1.2 1.6	19 21
87304C	2.0 to 26.5	2.0 to 18 GHz 18 to 26.5 GHz	1.1 1.4	19 18

**Power Rating:** 10 W, CW (2:1 maximum SWR)

**Connectors:** 3.5 mm (f), SMA compatible

**Signal Sources**

- (PN ESG-1) Using the ESG-D series and the 8922 GSM Test Set for GSM Applications  
[5965-7158E](#)
- Generating and Downloading Data to the ESG-D series for Digital Modulation  
[5966-1010E](#)
- Controlling TDMA Timeslot Power Levels in the ESG-D series  
[5966-4472E](#)
- Generate Digital Modulation with the ESG series Internal Dual Arbitrary Waveform Generator  
[5966-4097E](#)
- Customize Digital Modulation with the ESG-D series Real-time I/Q Baseband Generator  
[5966-4096E](#)
- Making Bit-error-rate Measurements with the ESG-D series  
[5966-4098E](#)
- 8643A, 8644B, 8664A, 8665A/B High Performance RF Signal Generators  
[5091-2580E](#)
- Low Phase Noise Applications of the 8662A and 8663A Synthesized Signal Generators  
[5953-8435](#)
- Using the ESG-D Series Multicarrier, Multichannel CDMA Personality for Component Test, Option UN5  
[5968-2981E](#)
- Generating Custom, Real-World Waveforms for 3G Wireless Applications  
[5968-8388E](#)
- ESG Signal Generator/Option 201 Real-time IS-2000 Mobile Receiver Measurements  
[5968-9551E](#)
- (PN 8360-2) Obtaining Flat Test Port Power with the 8360 User Flatness Correction Feature  
[5952-8090](#)
- (PN 8360-3) Generating Scan Modulation Patterns  
[5091-0226E](#)
- (PN 8360-4) Performing Two-Tone Measurements with the 8360  
[5091-0227E](#)
- (PN 8644A-1) Phase Noise Measurements with the 8644A and 8655A Signal Generators  
[5951-6729](#)
- (PN 8780A-2) Modulation Solutions RF & Microwave Receivers  
[5952-1416](#)
- (AN 1298) Digital Modulation in Communications Systems—An Introduction  
[5965-7160E](#)
- (AN 1306-1) 8 Hints for Making Better Measurements Using RF Signal Generators  
[5967-5661E](#)
- (AN 1307) Testing CDMA Base Station Amplifiers  
[5967-5486E](#)
- (AN 1311) Understanding CDMA Measurements for Base Stations and Their Components  
[5968-0953E](#)

- (AN 1312) Understanding GSM Transmitter Measurements for Base Stations and Their Components  
[5968-2320E](#)
- (AN 1313) Testing and Troubleshooting Digital RF Communications Transmitter Designs  
[5968-3578E](#)
- (AN 1314) Testing and Troubleshooting Digital RF Communications Receiver Designs  
[5968-3579E](#)
- (AN 1333) Performing Bluetooth RF Measurements Today  
[5968-7746E](#)

**Signal Analyzers**

- Scalar Network Analysis with the 8590 Series Spectrum Analyzers, 85630A Scalar Transmission/Reflection Measurement Test Set and 85714A Scalar Measurement Personality  
[5091-1338E](#)
- 346B Noise Source Technical Data  
[5953-6452](#)
- 3587S Demo Video  
[5964-9460E/PAL](#)
- 3587S Product Overview  
[5964-3631E](#)
- 71000 Series MMS Spectrum Analyzers  
[5965-2818E](#)
- 71209A 26.5 GHz Microwave Spectrum Analyzer Product Overview  
[5091-2581E](#)
- 71910A Wide Bandwidth Receiver Technical Data  
[5964-3895E](#)
- 85719A Noise Figure Measurement Personality and 8590E Option 119 Technical Data  
[5091-4800E](#)
- 87405A Preamplifier Technical Data  
[5091-3661E](#)
- 89400 Series VSAs Configuration Guide  
[5964-3630E](#)
- 89411A 21.4 MHz Downconverter Technical Data  
[5962-7210E](#)
- 89450A DMCA Radio Test Application Personality Product Overview  
[5963-1835E](#)
- 89451A Radio Test Personality Product Overview  
[5964-4098E](#)
- (PN 8590-2) Time-Gated Spectrum Analysis: New Measurement Fundamentals  
[5952-3685](#)
- (PN 8590EM-1) Electromagnetic Compatibility—Guide to Performing Precompliance Conducted and Radiated Emissions  
[5964-2151E](#)
- (PN 8590E/4Q, 859X) DVB-C Solutions  
[5965-4991E](#)
- (PN) Add Digitized Burst Signal Measurements Capability to 8560 E-Series Spectrum Analyzers  
[5091-5837E](#)
- (PN 85719A-1) Maximizing Accuracy in Noise Figure Measurements  
[5091-4801E](#)

- (PN 70000) Series Spectrum Analyzer Programming Code Compatibility to the 8566B  
[5091-2583E](#)
- (PN 71910A) Extending Vector Signal Analysis to 26.5 GHz with 20 MHz Information Bandwidth (71910A, 89400/10A/40A)  
[5964-3586E](#)
- (PN 8902A-2) Accurate Signal Characterization at Millimeter-Wave Frequencies  
[5953-8436](#)
- CDMA Solutions from Agilent  
[5966-3058E](#)
- GSM Solutions from Agilent  
[5966-1550E](#)
- Understanding CDMA Measurements for Base Stations and Their Components  
[5968-0953E](#)
- Understanding GSM Transmitter Measurements for Base Transceiver Stations and Mobile Stations  
[5968-2302E](#)
- (AN) Designing and Testing 3GPP W-CDMA Base Stations  
[5980-1239E](#)
- (AN) Designing and Testing 3GPP W-CDMA User Equipments  
[5980-1238E](#)
- (AN) Designing and Testing cdma2000 Mobile Stations  
[5980-1237E](#)

**RF Microwave Measurement System**

- RF & Microwave Test Accessories Catalog  
[5968-4314EN/EUS](#)

**Network/Spectrum Analyzers**

- Agilent's Family of Combination Analyzers 4395A/96B Awareness Brochure  
[5965-9374E](#)
- 4395A Network/Spectrum/Impedance Analyzer Technical Specification  
[5965-9340E](#)
- 4396B 1.8 GHz Network/Spectrum Analyzer  
[5965-6311E](#)
- Wideband Microwave Spectrum Analysis and Vector Signal Analysis 71910A, 71910P, and 89410A, Brochure  
[5965-7916E](#)
- (PN 4395/96-1) How to Measure Noise Accurately Using Agilent Combination Analyzers  
[5966-2292E](#)
- (PN 4395-1) ADSL Copper Loop Measurements  
[5968-1196E](#)

**Network Analyzers**

- 87050/75A/B Custom Multiport Test Sets, Product Overview  
[5964-3830E](#)
- (PN 8757-2) V and W Band Millimeter Scalar Measurements Using the 8757 Scalar Network Analyzer  
[5954-8380](#)
- (PN 8757-5) Measuring Voltage-Controlled Devices  
[5954-1537](#)
- (PN E5100A/B) Crystal Resonator Measuring Functions of E5100A/B Network Analyzer  
[5965-4972E](#)
- (PN 8720-1) Amplifier Measurements with the 8720C  
[5091-1942E](#)
- (PN 8720-2) In-Fixture Measurements with the 8720C  
[5091-1943E](#)
- (PN 8510-6) On-Wafer Measurements Using Cascade Prober  
[5954-1579](#)
- (PN 8510-8A) Applying TRL Cal to Non-coaxial Measurements  
[5091-3645E](#)
- (PN 8510-13) Measuring Noninsertable Devices  
[5956-4373E](#)
- (PN 8510-14) Using Multiple Test Sets with the 8510C  
[5967-5886E](#)
- (PN 8510-15) Lightwave Component Measurements  
[5952-3524](#)
- (PN 8510-16) Controlling Test Port Power Flatness  
[5091-0467E](#)
- (PN 8510-17) Measuring Chip Capacitors with the 8510C Network Analyzers and Inter-Continental Microwave Test Fixtures  
[5091-5674E](#)
- (PN 8510-18) Testing Amplifiers and Active Devices with the 8510 Network Analyzer  
[5963-2352](#)
- (PN 8510xF-2) Using Power Leveling to Control Test Port Output Power  
[5968-5270E](#)
- (PN 8753-1) Amplifier Measurements Using the 8753 Network Analyzer  
[5956-4361](#)
- (PN 8753-2A) Mixer Measurements Using the 8753 Network Analyzer  
[5952-2771](#)
- (PN 8753-5) Mixer Measurement with 8753C and 8625A Synthesized  
[5091-1100E](#)
- (PN8753ES) Testing Duplexers Using an Agilent 8753ES Option H39 Three-port Network Analyzer  
[5968-8987E](#)

- (AN 327-1) Extended Dynamic Range of Scalar Transmission Measurements  
[5953-8882](#)
- (AN 1291-1) 8 Hints for Making Better Network Analyzer Measurements  
[5965-8166E](#)
- (AN 1287-1) Understanding the Fundamental Principles of Vector Network Analysis  
[5965-7707E](#)
- (AN 1287-2) Exploring the Architectures of Network Analyzers  
[5965-7708E](#)
- (AN 1287-3) Applying Error Correction to Network Analyzer Measurements  
[5965-7709E](#)
- (AN 1287-4) Network Analyzer Measurements: Filter and Amplifier Examples  
[5965-7710E](#)
- (AN 1287-5) Improving Throughput in Network Analyzer Applications  
[5966-3317E](#)
- (AN 1287-6) Using a Network Analyzer to Characterize High-Power Components  
[5966-3319E](#)
- (AN 1287-7) Improving Network Analyzer Measurements of Frequency-translating Devices  
[5966-3318E](#)
- (AN 1287-8) Simplified Filter Tuning Using Time Domain  
[5968-5328E](#)
- (AN1287-9) In-fixture Measurements Using Vector Network Analyzers  
[5968-5329E](#)

**Power Meters**

- 70100A Power Meter Modular Measurement System Catalog  
[5965-2818E](#)
- EPM Series Power Meter and E-Series Power Sensors, Brochure  
[5965-6380E](#)
- EPM Series Power Meters and E-Series Power Sensor, Technical Data  
[5965-6382E](#)
- EPM Series Power Meters and E-Series Power Sensors, Configuration Guide  
[5965-6381E](#)
- E-Series E9300 Power Sensors, Product Overview  
[5968-4960E](#)
- Fundamentals of RF and Microwave Power Measurements, Application Note 64-A  
[5965-6630E](#)
- 4 Steps for Better Power Measurements, Application Note 64-4A  
[5965-8167E](#)

**Noise Figure**

- 8970B, 8790S/V, 8971C Noise Figure Measurement Products  
[5091-6049E](#)
- 346A/B/C Broadband Noise Sources Technical Data  
[5953-6452E](#)
- R/Q347B Solid State Noise Sources  
[5954-8888](#)
- 70875A Noise Figure Meter Personality for MMS Spectrum Analyzers Product Overview  
[5965-5022E](#)
- 85719A Noise Figure Measurement Personality for 8590E Series Spectrum Analyzer  
[5091-4800E](#)
- (PN 8970B/S-2) Applications and Operation of the 8970B Noise Figure Meter and 8970S MW Noise Figure Measurement System  
[5954-8896](#)
- (PN 8970B/S-3) Noise Parameter Measurement Using the 8970B Noise Figure Meter and the ATN Model NP4 Noise Parameter Test Set  
[5952-6639](#)
- (PN 8970B/S-4) Displaying 8970B Noise Figure Meter Measurements on the 8757 Scalar Network Analyzer  
[5959-8742](#)
- (AN 57-1) Fundamentals of RF and Microwave Noise Figure Measurements  
[5952-8255E](#)
- (AN 57-2) Noise Figure Measurement Accuracy  
[5952-3706](#)

**RF & Microwave Test Accessories**

- Custom Microwave Switch Matrixes  
[5966-2916E](#)
- (PN 8625A) Performing Two-tone Measurements with the 8625A  
[5091-2838E](#)
- (PN) ESA-L1500A 1.5 GHz Portable Spectrum Analyzer  
[5965-6309E](#)

**EMI/EMC Testing**

- EMC Precompliance Cookbook Measurements  
[5968-3661E](#)

Many of these literature pieces are available at:

[www.agilent.com/find/tmc](http://www.agilent.com/find/tmc)



*See also*  
MMS Products 90  
Network Analyzers 271  
Consulting Services 76

**EMI/EMC Test Systems 334**

**Antenna & Radar Cross-Section Measurements 337**

**Signals Development & Intercept Solutions 338**

**Phase Noise Measuring Systems 341**

**RF & Microwave Measurement Systems 342**

*See also*  
Consulting Services 76

**Additional Literature 346**

E7400A  
84105EM  
84115EM



## E7400A Series EMC Analyzers

Whether your industry is information technology, automotive, communications, or medical electronics, you need to evaluate the EMI performance of your products during the development phase. With Agilent's E7400A series EMC analyzers, you can evaluate performance quickly and easily.

Compare your products conducted and radiated emissions performance to the following regulatory agency limits:

EN55011, EN55014, EN55022, FCC Part 15, VCCI, VFG, and GB9254 or generate and save your own limit lines.

The E7400A series EMC analyzers have the following functionality and features to speed you through measurements.

- Detectors to perform peak, quasi-peak, and average measurements.
- Complete measurement setups including span and EMI bandwidths.
- Display two limit lines and margins
- Corrections for antennas, cables, and amplifiers
- Measure peak, quasi-peak, and average amplitudes of 2000 signals and store the results into the internal list.
- Use the "Zone" feature to zoom in on a signal while viewing the broad spectrum
- Built-in 3 inch disk drive
- Large, crisp color display
- Built-in preamplifier with 20 dB nominal gain
- Sort, remeasure, mark, and delete signals in the internal list
- Standard GPIB and parallel ports
- Battery pack available
- Edit or customize and store limit lines and correction factors
- Optional built-in tracking generator to 3 GHz

The E7400A series EMC analyzers are offered in the following frequency ranges:

- E7401A:** 9 kHz to 1.5 GHz
- E7402A:** 9 kHz to 3.0 GHz
- E7403A:** 9 kHz to 6.7 GHz
- E7404A:** 9 kHz to 13.2 GHz
- E7405A:** 9 kHz to 26.5 GHz

## 84105EM Design Development System

Identification, isolation, and resolution of problem emissions early in the design process is key to a successful product introduction. With the 84105EM design development system, you can easily isolate problems using the close field probes supplied with the system. The calibrated close field probes give very repeatable measurements ensuring that assessments of redesigns will produce meaningful results. The system is based on the E7401A (9 kHz to 1.5 GHz) and includes the 11945A close field probe set (9 kHz to 1.0 GHz). An optional preamplifier, 11909A is available for additional sensitivity.



## 84115EM Pre-Production Evaluation System

The 84115EM system has everything you need to perform radiated and conducted emissions measurements on your product. The 84115EM is based on the E7401A EMC analyzer, which includes quasi-peak detection and EMI bandwidths. The system also includes the following:

11955A biconical antenna, 11956A log periodic antenna, 11968C tripod, 11966L 10 meter cable, 11967D line impedance stabilization network, 11947A transient limiter and 11945A close field probe set.

In addition, the system includes the new E7415A EMI measurement software to automate the measurement process.

### Key Literature

E7400A Series EMC Analyzer Brochure, p/n 5968-2516E  
 ESA/EMC Configuration Guide, p/n 5968-3412E  
 E7400A Series Technical Specifications, p/n 5968-3662E  
 EMC Accessories Catalog, p/n 5966-1188E  
 EMC Precompliance Cookbook (AN 1328), p/n 5968-3661E

### Ordering Information

**84105EM** EMC Design Development System  
 Opt 909 add 11909A preamplifier  
**84115EM** EMC Pre-Production Evaluation System  
 Opt 909 adds 11909A preamplifier  
**E7401A** 9 kHz to 1.5 GHz  
**E7402A** 9 kHz to 3.0 GHz  
**E7403A** 9 kHz to 6.7 GHz  
**E7404A** 9 kHz to 13.2 GHz  
**E7405A** 9 kHz to 26.5 GHz

## PC Software for the E7400A Series

BenchLink XL PC software provides easy transfer of ESA measurement trace data directly into MS Excel spreadsheets or screen images into MS Word documents for analysis, archiving, presentations, or printing. Transfer measurement results over GPIB, RS232, or LAN (using two PCs or an E2050A GPIB/LAN adapter). Save and restore analyzer states. Unattended operation with repetitive sequence of measurement transfers by date and time. BenchLink XL is included standard with GPIB and RS232 options.

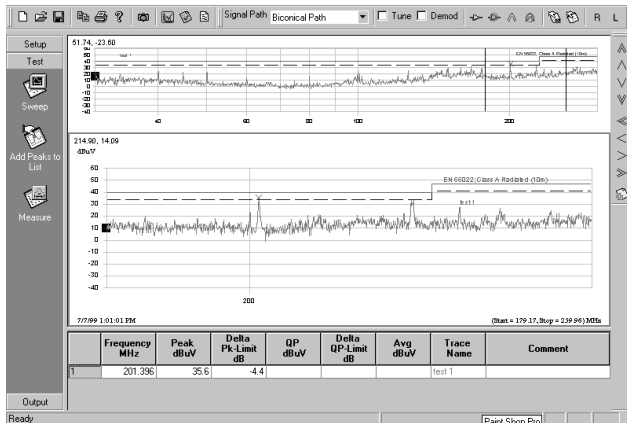

### E7415A EMI Measurement Software

Choose the level of automation you need, from simple data capture from your EMC analyzer or receiver to fully automated EMI measurements. With the E7415A, you can select the measurement resolution over the span of interest or use the auto-select feature.

Zoom in on an area for a closer look simply by dragging a cursor. Point and click to mark individual signals and add them to a list or use the "Add Peaks to List" function to add all the signals above a limit or margin to a list with one click. Highlight signals in the list to measure peak, quasi-peak and average amplitude or tune and listen.

Generate a report by selecting from a wide range of entries. Your report may include a graph, limit lines, equipment table, transducer factors etc.

The E7415A controls the E7400A series EMC analyzers with asset control modules for the 8590EM series EMC analyzer and 8546A/42E EMI receivers.

Optional test sequencing allows "stacking" of automated measurements, providing higher throughput.

Optional tower and turntable control allows the user to drive these devices directly from the PC or to embed control within measurement sequences, allowing for example, customized maximization routines.

### 11940A and 11941A Close-Field Probes and 11945A Close-Field Probe Set

These handheld probes are designed to measure magnetic-field radiation from surface currents, slots, cables, and ICs for EMC diagnostic and troubleshooting measurements. Their unique design results in a high level of electric-field rejection. This significantly reduces errors, thus allowing calibrated and repeatable measurements.

The 11941A operates from 9 kHz to 30 MHz, the 11940A, from 30 MHz to 1 GHz. Five antenna factors appear on each probe for calculating absolute magnetic-field strength (dBμA/m) from the dBμV reading of a spectrum analyzer. Each probe is calibrated and comes with a 2-meter RG-223 coaxial cable, and SMA(f)-to-type-N(m) adapter, and an SMA (f)-to-BNC(m) adapter.

The close field probe set includes both the 11940A and 11941A probes for full coverage from 9 kHz to 1 GHz. Option E51 adds the 11909A preamplifier, a 36-inch (914-mm) type-N cable, and a carrying bag for storage and protection of the entire set.

### 119XX Series Antennas

These antennas are individually calibrated and shipped with a calibration certificate showing actual performance data. The series includes the following products:

Model		Frequency Range
11955A	Biconical Antenna <sup>1</sup>	30 to 300 MHz
11956A	Log Periodic Antenna <sup>1</sup>	200 MHz to 1 GHz
11966A	Active Loop H-Field Antenna	10 kHz to 30 MHz
11966B	Active Rod E-Field Antenna	100 Hz to 50 MHz
11966C	Biconical Antenna	30 to 300 MHz
11966D	Log Periodic Antenna	200 MHz to 1 GHz
11966E	Double-Ridged Waveguide Horn Antenna	1 to 18 GHz
11966G	Conical Log Spiral Antenna	1 to 10 GHz
11966J	Double-Ridged Waveguide Horn Antenna	18 to 40 GHz
11966K	Magnetic Field Pickup Coil	20 Hz to 50 kHz
11966L	Coax Cable, Type-N	10 m
11966N	Log Periodic Antenna	200 MHz to 5 GHz
11966P	Broadband Antenna	30 MHz to 1 GHz
11947A	Transient Limiter	9 kHz to 20 MHz

### Key Literature

EMC Accessories Catalog, p/n 5966-1188E

<sup>1</sup> Typical cal factor supplied

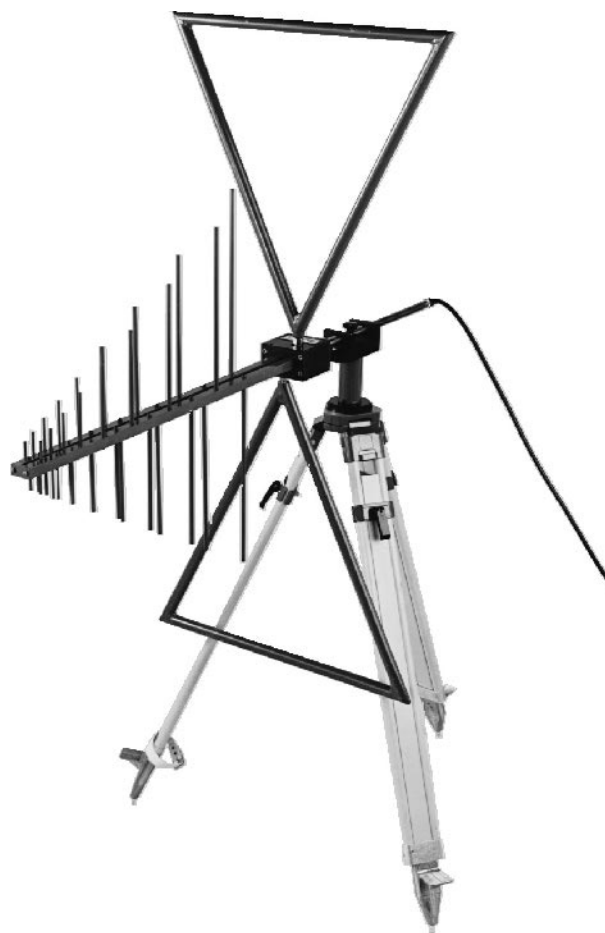

11966P Broadband Antenna with optional rugged tripod

### 11967 Series Current Probes

This series is designed for MIL-STD-461/462 conducted-emission measurements on power and interconnecting leads. Used with 10  $\mu$ F capacitors, Agilent p/n 0160-6683.

Model	Frequency Range
11967A Current Probe	15 kHz to 50 MHz, dc to 60 Hz powerlines
11967B Current Probe	20 Hz to 2 MHz, dc to 400 Hz powerlines

### 11967E Line Impedance Stabilization Network

This is a single phase, 25 ampere unit used for commercial conducted emissions measurements and meets the requirements for FCC, CISPR and European Norms. The 11967E LISN is supplied with a NEMA power outlet standard or optional SCHUKO, British, and Australian power outlets.

### 11967D Line Impedance Stabilization Network

Used for commercial conducted measurements. Maximum current 10 amps. Includes options for SCHUKO and British power outlet connectors.

### 11968 Series Positioning Devices

This series includes manually-operated antenna masts and turntables.

Model	Description
11968C	Non-metallic antenna tripod; minimizes unwanted reflections in the test environment

### 11909A Preamplifier

Improve receiver, EMC analyzer or spectrum analyzer sensitivity for more accurate radiated emissions measurements. This amplifier has 32 dB gain with a 1.8 dB noise figure. This amplifier is ideal for use with the 11940A and 11941A close field probes to detect low level signals from and device-under-test. Frequency range is 9 kHz to 1 GHz.

### 8449B Microwave Preamplifier

This high-gain, low-noise preamplifier adds sensitivity for MIL-STD radiated measurements. Frequency range is 1 to 26.5 GHz (see page 25.27).

### Ordering Information

- 11940A Close-Field Probe, 30 MHz to 1 GHz
- 11941A Close-Field Probe, 9 kHz to 30 MHz
- 11945A Close-Field Probe Set, 9 kHz to 1 GHz
  - Opt 001 Rotary Joints
  - Opt 003 Delete Cables and Adapters (2 sets)
  - Opt E51 Add 11909A Preamplifier Carrying Bag, 36-in Type-N Cable
- 11947A Transient Limiter, 9 kHz to 200 MHz
- 11955A Biconical Antenna<sup>1</sup>
- 11956A Log Periodic Antenna<sup>1</sup>
- 11966A Active Loop H-Field Antenna, 10 kHz to 30 MHz
- 11966B Active Rod E-Field Antenna, 100 to 50 MHz
- 11966C Biconical Antenna, 30 to 300 MHz
- 11966D Log Periodic Antenna, 200 MHz to 1 GHz
- 11966E Double-Ridged Waveguide Horn Antenna, 1 to 18 GHz
- 11966F Conical Log Spiral Antenna, 200 MHz to 1 GHz
- 11966G Conical Log Spiral Antenna, 1 to 10 GHz
- 11966J Double-Ridged Waveguide Horn Antenna 18 to 40 GHz
- 11966K Magnetic Field Pickup Coil, 20 Hz to 50 kHz
- 11966L Coax Cable, Type-N
- 11966N Log Periodic Antenna, 200 MHz to 5 GHz
- 11966P Broadband Antenna, 30 MHz to 1 GHz
- 11967A Current Probe, 15 kHz to 50 MHz
- 11967B Current Probe, 20 Hz to 2 MHz
- 11967E 25 amp Line Impedance Stabilization Network
- 11967D LISN NEMA Connector
  - Opt 001 SCHUKO Connector
  - Opt 002 British Connector
- 11968B Manual Antenna-Positioning Mast
- 11968C Antenna Tripod
- 11909A Preamplifier, 9 kHz to 1 GHz
- 8449B Microwave Preamplifier, 1 to 26.5 GHz
- E7415A EMI Software

<sup>1</sup>Typical antenna factors supplied



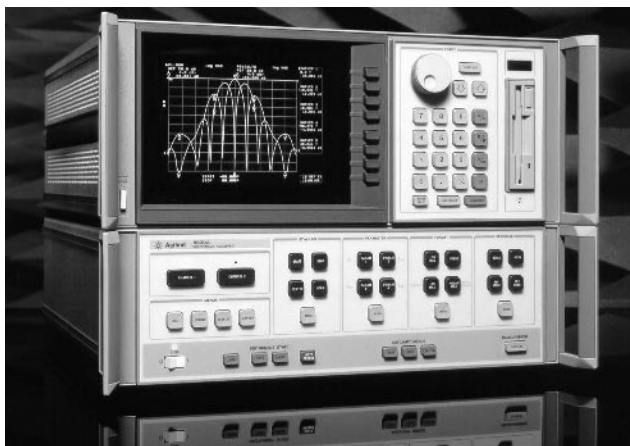

8530A Microwave Receiver

- Measurement speeds of up to 5000 points/second
- Fast multiple-channel measurements
- Excellent microwave performance and accuracy
- Built-in graphical display and analysis capability

### 8530A Microwave Receiver

The 8530A is a fast and accurate microwave receiver designed for both manual and automated antenna measurement and radar cross-section measurement applications. It features fast data acquisition speeds, excellent sensitivity wide dynamic range, multiple test channels, and fast frequency agility—without compromising measurement accuracy. The receiver provides broad frequency coverage from 45 MHz to 50 GHz, with extensions to 110 GHz.

### Easy Upgrades for Existing Antenna Ranges

The 8530A microwave receiver can be a replacement receiver for existing antenna or RCS range receivers. With the 85370A antenna position encoder, the 8530A receiver can be interfaced to virtually any positioning system. Also, any 8510 network analyzer can be upgraded to a 8530A microwave receiver and still retain network analyzer capability.

### Far-field Antenna Measurements

Far-field antenna measurement applications require good measurement sensitivity, and immunity to spurious signals. Agilent instrumentation fulfills these demanding requirements. Systems can be configured to operate from 0.1–110 GHz. A typical far-field antenna measurement system includes an 8530A microwave receiver, an 85310A distributed frequency downconverter, which consists of an 85309A LO/IF signal distribution unit, and 85320A/B test and reference mixers. 8360 series synthesized sources are used for RF and LO signals.

### Near-field Antenna Measurements

Agilent instrumentation fulfills the demanding requirements imposed by near-field measurement applications. Either the 8700 series of network analyzers, or the 8530A microwave receiver with one of two different frequency downconverters; the 85310A distributed frequency downconverter, or the 8511A/B frequency converter can be used in near-field applications.

### Radar Cross-Section Measurements

Agilent instrumentation is meeting the challenges of RCS measurements by offering a choice of two different frequency downconverters. The 8511B provides broadband frequency coverage from 45 MHz to 50 GHz with very fast frequency agility. The 85310A frequency downconverter provides excellent sensitivity, and frequency coverage from 0.1 to 110 GHz.

### Antenna Measurement Solutions

Agilent's channel partner, Nearfield Systems, Inc. (NSI) provides application expertise, system engineering and configurations, integration, installation, performance verification, and training for far-field and near-field solutions.

### Ordering Information

**8530A** Microwave receiver  
**85310A** Distributed frequency downconverter  
**8511A** Frequency converter (45 MHz to 26.5 GHz)  
**8511B** Frequency converter (45 MHz to 50 GHz)

### Additional Information

[www.agilent.com/find/antenna](http://www.agilent.com/find/antenna)

### Channel Partners for Network-Analyzer Applications

Several Agilent Channel Partners provide measurement solutions that combine hardware and/or software with Agilent network analyzers. Please contact the following companies directly for more information about their products and services.

#### Antenna Measurement Solutions

Nearfield Systems offers a complete line of antenna-measurement solutions including measurement-automation software and antenna-positioning products.

**Phone:** (310) 518-4277  
**Fax:** (310) 518-4279  
**E-mail:** [sales@nearfield.com](mailto:sales@nearfield.com)  
**Web:** [www.nearfield.com](http://www.nearfield.com)

#### Differential Measurements of Balanced Components

ATN Microwave's ATN-4000 series of multiport test systems provide differential measurements of three- or four-port, fully balanced or single-ended-to-balanced components, across the entire RF and microwave frequency range. They incorporate full 4-port error correction to provide exceptional measurement accuracy. The test systems include a 4-port test set, an 8753 or 8720 family network analyzer, and Windows-based software. For more information, please ask for Agilent literature number 5968-5480E or contact ATN Microwave directly.

**Phone:** (978) 667-4200 X16  
**Fax:** (978) 667-8548  
**E-mail:** [sales@atn-microwave.com](mailto:sales@atn-microwave.com)  
**Web:** [www.atn-microwave.com](http://www.atn-microwave.com)

#### On-Wafer Probing and Package/Interconnect Characterization

Cascade Microtech is the world leader in advanced microelectronic probing solutions. They offer a wide range of RF and microwave probes, probe stations, and software for on-wafer and module test, and for characterizing packages and interconnects.

**Phone:** (503) 601-1000  
**Toll free:** 1-800-550-3279  
**Fax:** (503) 601-1002  
**E-mail:** [sales@cmicro.com](mailto:sales@cmicro.com)  
**Web:** [www.cascademicrotech.com](http://www.cascademicrotech.com)

#### Test Fixtures and Device Handlers

Inter-Continental Microwave offers an extensive line of standard RF and microwave test fixtures and non-coaxial calibration standards. They also provide custom design services to satisfy unique customer requirements. ICM also designs and manufactures custom automatic-device-handling and probing systems to maximize production throughput.

**Phone:** (408) 727-1596  
**Fax:** (408) 727-0105  
**E-mail:** [icmfixture@aol.com](mailto:icmfixture@aol.com)  
**Web:** [www.icmicrowave.com](http://www.icmicrowave.com)

For Agilent's disclaimer regarding third-party products, please see page 34.

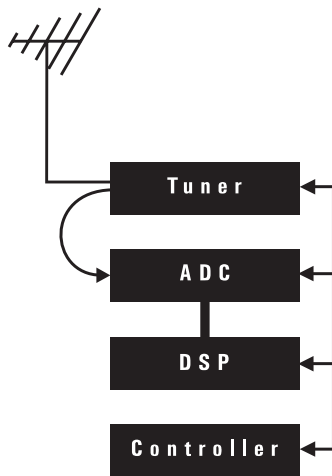

Wide band receiver block diagram. (Antenna/Tuner/ADC/DSP)

Signals development and intercept is the art of finding and analyzing signals that may not want to be found. Agilent Technologies offers a selection of products to help with this task. Each product has distinctive capabilities that make it the preferred system for a particular job.

Use the E3238 signals development system for wide-band signal search, classification, and monitoring. This turn-key modular VXI system is noted for sweeping fast with excellent frequency resolution. The tuner has a wide IF bandwidth, at least 8 MHz and is stepped, not continuously swept, across the spectrum. The wide IF speeds search by enabling fast tuning and minimizing the number of steps needed to cross a given spectrum segment. The tuner steps so the IF can be digitized. The ADC digitizes the entire IF without degrading the signals and sends the samples to the DSP where a Fast Fourier Transform (FFT) is calculated. The FFT provides selectable frequency resolution and noise floor reduction.

The E3238 improves search speed by 10 or 100 times over narrow-band swept search techniques used in other systems. These systems tune a relatively narrow audio bandwidth receiver across the spectrum. Typically such a system can sweep 50 MHz in 2.5 seconds with 7.5 kHz frequency resolution. The E3238 can sweep the same spectrum in 50 ms.

Use the 3587 wide-band recording and signal analysis system to evaluate and characterize signal structure. This turn-key modular VXI system is noted for its measurement performance, signal processing tools, fast flexible display types and presentation formats. The 3587 uses digital sampling and the FFT to form a spectrum of the signal, in real time or on data it records. This technique is useful for measuring signals with a resolution of a few  $\mu$ Hz to 100 kHz, and provides frequency, amplitude, and phase information. With its real-time signal analysis capability, and its wide-band recording features, the 3587 is able to capture and analyze periodic as well as random and transient signals and events.

- Measure DC to 3 GHz
- Up to 8 MHz instantaneous frequency span
- 1 MHz real-time DSP bandwidth

- Frequency, time, and amplitude domain displays
- Spectrogram and waterfall displays
- Compatible with various downconverters

3587

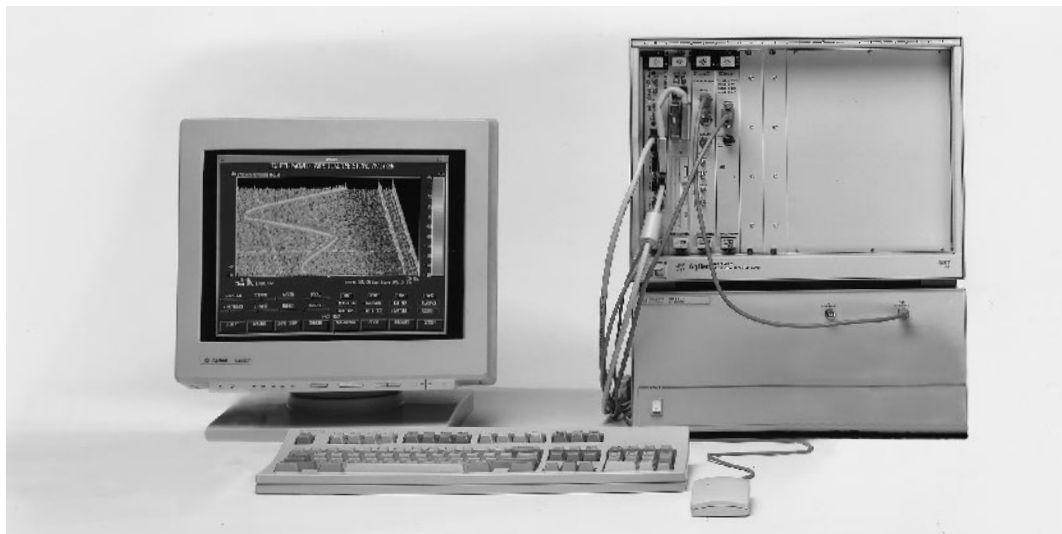

3587

### 3587 Real-Time Signal Analysis System

The 3587 real-time signal analysis system has the measurement power and flexibility you need to capture and analyze real world signals. Its combination of speed, dynamic range, presentation flexibility, signal capture memory, and instrument-like operation will help you analyze non-stationary and low-level signals, even those close to much higher level signals, a higher percentage of the time.

#### 8 MHz Input Bandwidth

Analyze data with up to 8 MHz bandwidth. The 3587 uses a 20 MSa/s 23 bit ADC module to digitize signals. This A/D is fully alias-protected to assure the Nyquist valid sampling that is key for signal analysis. It also provides up to -110 dBfs of spurious-free dynamic range. A 16 dB noise figure provides excellent sensitivity to complement this dynamic range. Extend the measurement range of the 3587 with a selection of HF and VHF/UHF downconverters.

#### 1 MHz Real-Time DSP Bandwidth

The digital signal processing module in the 3587 contains 250 MFLOPs of raw computational power. That power gives this signal analyzer 1 MHz of real-time bandwidth. That means you can monitor any 1 MHz span in the frequency range of the 3587 continuously, with <2 kHz frequency resolution and zero revisit time.

#### Versatile Data Display

Monitor and analyze signals with a choice of frequency-domain, time-domain, and histogram displays. Frequency-domain displays include single-trace spectrums, multi-spectrum waterfalls, spectrograms, and rollograms. Rollograms can update at better than 800 spectrums per second. Time-domain displays include single trace, strip chart, and waterfall. Histograms, probability density function (PDF), and cumulative density functions (CDF) are standard. Other features include digital persistence, digital image enhancement filtering, and a variety of marker functions. Option AGG allows you to create your own markers and modify signal data before it is displayed, as well as modify the user interface.

#### Signal Capture Memory (Option ATR)

Save important wideband signals using the throughput-to-disk option (Option ATR) and the N2216 high-speed data disk module. When the N2216 is configured with 100 GB capability you can record 4 MHz bandwidth signals for more than 80 minutes. Then play the signals back and analyze them with the 3587.

### System Advantages

The 3587 is a turn-key VXI system. Software is loaded at the factory, so you can take the system out of the box, hook up a few cables, and start making measurements right away.

### Specifications

#### Frequency

- Range:** DC to 8 MHz
- Spans:** 0.95 Hz to 8 MHz, octave steps
- Resolution:** 51 to 12,801 lines
- Real-time Bandwidth:** 1 MHz (801 lines, 0% overlap, spectrogram mode, rms averaging, 16-bit word width, 1024 x 768 pixel display)

#### Amplitude (with E1437ADC)

- Input Range:** +30 dBm to -24 dBm
- Accuracy:**  $\pm 0.03$  dB,  $f < 100$  kHz, 25° C,  $\pm 1$  V range, dc coupled alias filter on, digital filters off
- Input Impedance:** 50  $\Omega$ , > 40 dB return loss to 4 MHz
- Harmonic Distortion:** < -110 dBfs or -80 dBc, whichever is greater

#### Modes

- Averaging Modes:** Off, rms, peak, nth
- Marker Modes:** Single, relative (same trace, separate trace), marker to peak, marker to next peak, right/left, band power, noise power
- Memory Modes:** Save/recall, record/playback, signal capture
- Triggering Modes:** Free-run, level, magnitude, external
- Printer Output:** Print screen/print trace

### Key Literature

3587 Signal Analysis System Brochure, p/n 5963-2076E

For more information, visit our web site:

<http://www.agilent.com/tmo/datasheets/English/HP3587.html>

### Ordering Information

**3587 Real-Time Signal Analysis System**

**System may include:** controller, monitor, disk drive, DAT tape, VXI chassis, DSP module, HP-UX operating system, 35687B measurement/control software. For a complete configuration guide contact your local Agilent sales office. For a pre-bundled system, order 3587B.

\*Price will vary with configuration.

6



E3238

- 2.6 GHz/sec scanning rate with 15 kHz resolution
- Manual and automatic signal isolation tools
- Automatic energy detection tools
- Hand-off receiver control
- HP-UX and Windows NT 4.0

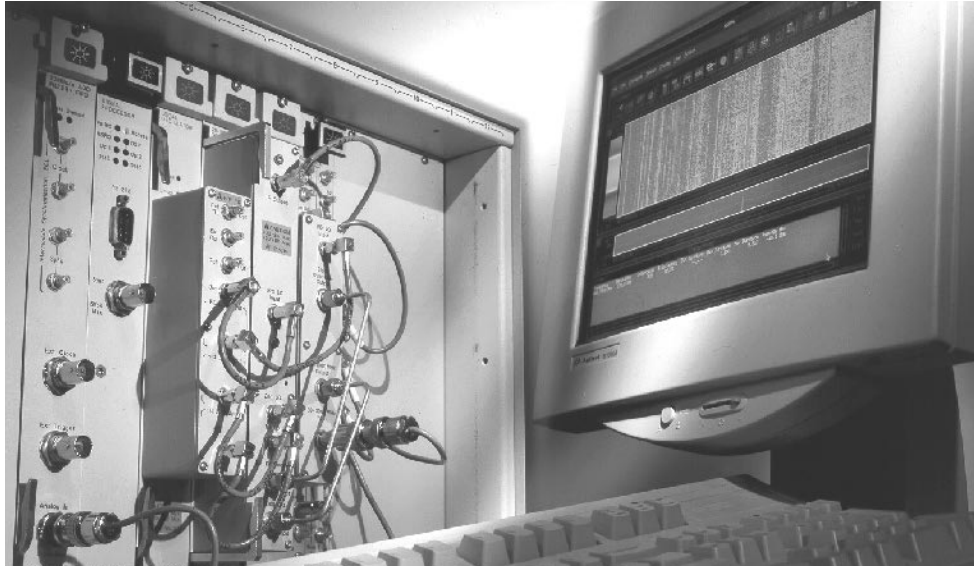

E3238

## E3238 Signals Development System

The E3238 is a commercial-off-the-shelf wideband signals development system capable of sweep rates as high as of 2.6 GHz/s with 15 kHz frequency resolution. Use VXI-based system speed detection, classification, and monitoring of signals of interest.

### General and Directed Search

Select from three search modes. Choose general search for fast, general purpose environment scanning. Choose directed search to sequentially scan up to 100 individual spectrum segments skipping the parts of the spectrum not critical to your mission. Choose the tuner lock search mode to stare continuously at a section of spectrum. A full selection of resolution bandwidths and averaging types are provided in all three modes.

### Manual Signal Isolation Tools

Use the E3238's mouse-controlled manual signal isolation tools directly on the signal trace. You don't have to take your eyes from an elusive signal to tune to it. Just drag a box around it with the mouse and the system will zoom the display to that signal. Place the cursor on the signal and press a mouse button to activate the frequency and amplitude marker. Assign a hand-off receiver to the signal with a simple drag-and-drop operation, or lock the hand-off receiver to the marker and listen to every signal as you move the marker on the trace. Multi-trace and spectrogram displays are provided.

### Automatic Energy Database

The E3238 has three user-selectable thresholds to automatically isolate signal energy from noise energy as part of its automated energy classification capacity. Once isolated the frequency, amplitude, bandwidth, duration, and 14 other parameters of every energy event above the threshold are stored in the energy history database. Use the automatic alarm function to search the energy history database for energies of interest and take action.

### Programming And Customizing

The user programming option (AS9) provides remote operation via Ethernet LAN or RS232, accessing all features, displays, and menus. This option also provides system-customizing capabilities. Expand the database or add software filters to block or remove unwanted energy database entries. Create a custom display, define new tasks for the alarm function to execute, add new menus, and more.

## System Advantages

The E3238 is a turn-key system. It comes to you from the factory with all the software loaded and all the hardware ready to hook up and run.

## Specifications

Using the 89431A – 2 to 2650 MHz downconverter

### Frequency

- Range:** 2 to 2650 MHz
- Spans:** 1 MHz to 2650 MHz, 1 Hz resolution
- Resolution:** 7.3 Hz to 120 kHz, octave steps
- Sweep Speed:** 2.6 GHz/s (using 15 kHz RBW)

### Amplitude

- Input Range:** -50 dBm to +25 dBm (5 dB steps)
- Sensitivity:** -159 dBm/Hz (-50 dBm range)
- Noise Figure:** 16 dB
- Spur Free Dynamic Range:** 70 dB

## Key Literature

E3238S Signals Development System Brochure, p/n 5963-2075E

For more information, visit our website:

<http://www.agilent.com/tmo/datasheets/English/E3238.html>

## Ordering Information

**E3238** Signals Development System

**Includes:** controller, monitor, disk drive, DAT tape, DSP module, ADC module, downconverter, RF MUX module, VXI chassis, HP-UX or Windows NT operating system, 35688C measurement/control software. For a complete configuration guide contact your local Agilent Technologies sales office. For a prebundled system, order E3238B or E3238N.

\*Price will vary with configuration.



- 50 kHz to 26.5 GHz with expand carrier frequencies to 110 GHz
- Quick and easy integration into your ATE system

- Ability to test a wide range of devices
- Measure AM noise directly



E5503A



E5503B

### E5500 Series Phase Noise Measurement Solutions

The new Agilent E5500 A-series phase noise measurement solutions have been designed to minimize production ATE test times for one-port VCOs, DROs, crystal oscillators, and synthesizers and to maximize the capability for R&D benchtop applications. In addition, with a standard offset range capability from 0.01 Hz to 100 MHz, the E5500 B-series provides the capability, flexibility, and versatility to meet changing and demanding needs placed upon the R&D engineer. By building upon 30 years of Agilent low phase noise, RF design and measurement experience, the E5500 series solutions continue to provide excellent measurement integrity, repeatability, and accuracy.

The E5500 phase noise measurement solutions use the power of a flexible software program to automate phase noise carrier measurements. The E5500 A-series solutions include the 70420A phase noise test set, which contains phase detectors and phase-lock loop circuitry, a high speed VXI digitizer with mainframe and high speed VXI-to-PC interface for base-band signal analysis, selected low-noise frequency downconverters, and measurement software. When combined with a PC running Windows NT 4.0, this series provides fast phase noise measurements of carrier frequencies from 50 kHz to 1.6 GHz, 6.0 GHz, 18 GHz, or 26.5 GHz over offset-from-carrier frequencies of 0.01 Hz to 4 MHz.<sup>1</sup> The E5500 B-series includes the 70420A phase noise test set, a Pentium PC running Windows NT 4.0, a PC digitizer, and an RF spectrum analyzer, selected low-noise frequency downconverters, and measurement software. This series of solutions provides phase noise measurements of carrier frequencies from 50 kHz to 1.6 GHz, 6.0 GHz, 18 GHz, or 26.5 GHz over offset-from-carrier frequencies from 0.01 Hz to 100 MHz. A variety of signal generators—such as the 8662A, 8663A, 8643A, 8644B, 8664A/B, 8665A—can also be added to provide a low-noise reference signal.

### Phase Noise Measurement Software

A graphical user interface provides measurement menus allowing the operator to specify the measurement process, including the calibration of the system. Several output formats are available to the user, including plots of the single-sideband phase noise power of the signal, integrated noise power, or the calculated Allan variance. A real-time measurement mode is available to monitor the level of phase noise and discrete spurs as changes are made to the device-under-test. The E5500 series phase noise measurement software requires a Pentium PC with 32 MBytes of RAM, a 1 GByte hard drive, and Windows NT 4.0.

<sup>1</sup> It can be extended to cover offset ranges up to 100 MHz.

### Specifications

#### E5500 A-Series

- E5501A:** 50 kHz to 1.6 GHz
- E5503A:** 50 kHz to 18.0 GHz
- E5504A:** 50 kHz to 26.5 GHz

#### E5500 B-Series

- E5501B:** 50 kHz to 1.6 GHz
- E5502B:** 50 kHz to 6.0 GHz
- E5503B:** 50 kHz to 18.0 GHz
- E5504B:** 50 kHz to 26.5 GHz

### Operating Characteristics

#### Offset Frequency Range

- A Models: 0.01 Hz to 4 MHz
- B Models: 0.01 Hz to 100 MHz

**System Noise Response<sup>2</sup>:** -180 dBc/Hz typically (>10 kHz offsets)

**System Spurious Response<sup>2</sup>:** -120 dBc typically

**Phase Detector Input Power:** (<1.6 GHz carrier frequency)

- R input = 0 to +23 dBm
- L input = +15 to +23 dBm

**Downconverter Input Range:** 1 GHz to 6 GHz;

1 GHz to 18 GHz; 1.5 GHz to 26.5 GHz

**External Noise Input Port:** 0.1 Hz to 100 MHz

**Measurement Accuracy:** ±2 dB (<1.0 MHz offsets); ±4 dB (<100 MHz offsets)

#### E5500 A-Series Optional Capabilities

- Extend offset range to 8, 10, and 100 MHz
- Add RF reference source
- Add high power input capability (includes  $\mu$ W phase and AM detectors)
- Extend carrier frequency to 110 GHz

#### E5500 B-Series Optional Capabilities

- Add RF reference source
- Add high power input capability (includes  $\mu$ W phase and AM detectors)
- Add remote SCPI programming client
- Extend carrier frequency to 110 GHz

<sup>2</sup> Without reference sources or downconverters

### Key Literature

- E5500 Series Phase Noise Measurement Solutions, Product Overview, p/n 5965-7590E
- E5500 Series Phase Noise Measurement Solutions Configuration Guide, p/n 5965-7589E

### Ordering Information

#### E5500A Series

#### E5500B Series

See configuration guide for detailed ordering information.

4352S

- Dedicated VCO and PLL parameters test system
- Excellent solution for LAB and production line
- Simple configuration and multifunctional system
- VCO tuning characteristics evaluation

- Outstanding phase noise measurement capability
- High resolution frequency transient measurement
- Automatic measurement capability and powerful analysis functions

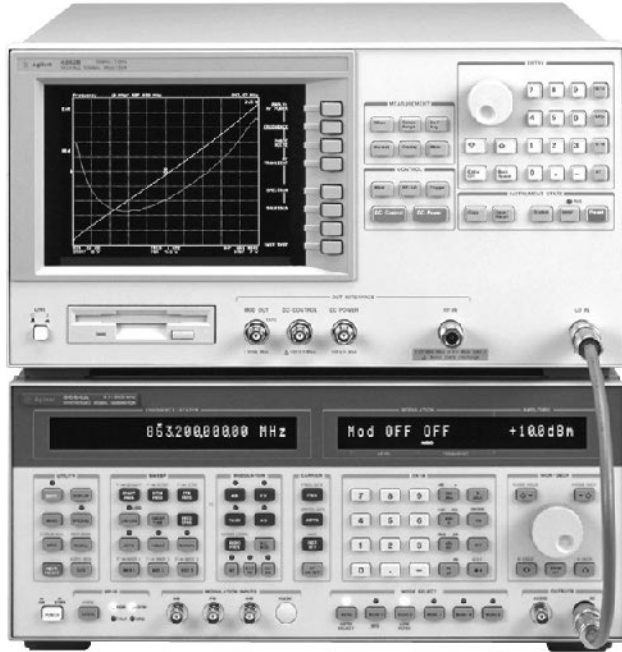

3GHz System

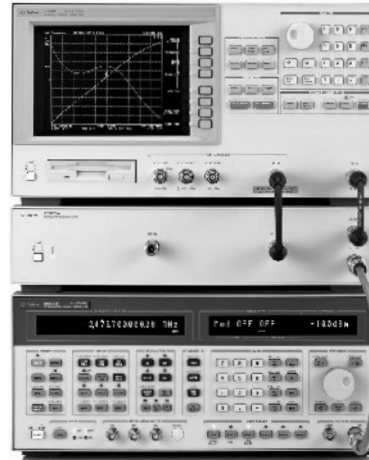

12.6 GHz System

### 4352S VCO/PLL Signal Test System



The Agilent 4352S test system can evaluate the characteristics of VCOs and PLLs that are essential to designing local oscillators used in RF wireless communication equipment. This system can provide both powerful analyzing capability for design evaluation in LAB and high speed measurement capability for production line test with 2 operating modes, "Signal Analyzer" and "VCO Tester" mode. The 4352S, which consists of the 4352B VCO/PLL Signal Analyzer and low-noise signal generator controlled by the 4352B, covers up to 3 GHz and can measure the main VCO/PLL evaluation parameters, RF power, frequency, phase noise, spectrum, frequency transient, DC consumption current and FM deviation. In addition, the 4352B provides and controls the DC power supply, the ultra low-noise DC control voltage source and the 1 kHz signal source necessary for VCO tuning characterizing.

When configured with the 43521A downconverter unit, the 4352S offers a dedicated and comprehensive VCO/PLL design and production measurement solution for manufacturers that must test at frequencies over 3 GHz. The enhanced 4352S is a complete system that offers a frequency range from 10MHz to 12.6GHz and is capable of measuring phase noise, RF power, transients, settling time, and many more parameters required for VCO/PLL evaluations.

This system can make high-speed measurements thanks to the dedicated firmware and "carrier lock multi-mode PLL" technology for phase noise measurement that enables the system lock unto the carrier of the measured signal automatically. In addition, the 4352B has excellent phase noise performance such as -157 dBc/Hz at 1 MHz offset typically, so that this test system can make reliable and repeatable phase noise measurement with up to 10 times reduction in measurement time. Actually it can measure 801 measurement points from 100 Hz to 10 MHz offset in 7.4 seconds/sweep. Besides the powerful phase noise measurement capability, the 4352S can measure frequency transient with 50 Hz frequency resolution and 12.5 micro seconds time resolution.

When the 71707A Microwave Downconverter is added to the standard system, the phase noise measurement can be performed up to 26.5GHz.

The 4352S improves your VCO and PLL evaluation efficiency and testing productivity dramatically.

### Measurement Display Examples

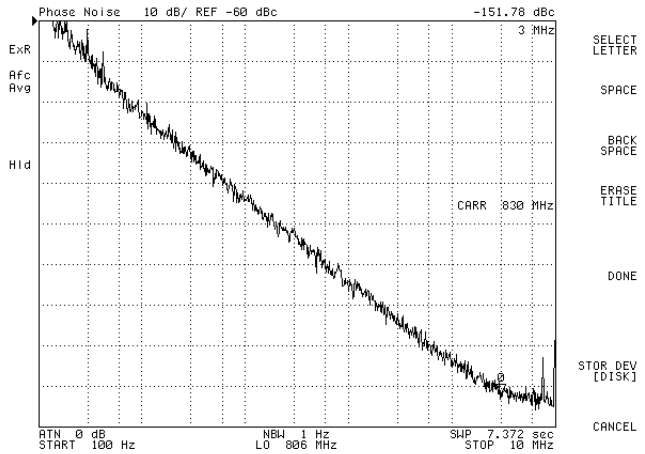

VCO phase noise measurement

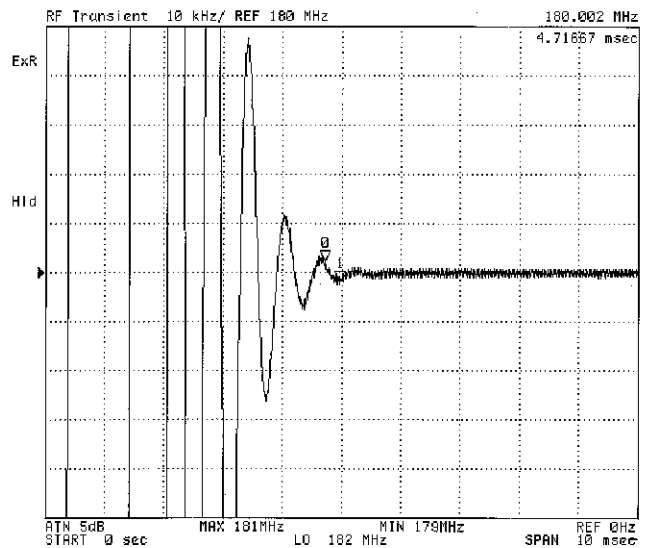

PLL frequency lockup time measurement

## Efficient Evaluation in Oscillator Circuit Design

The 4352S can measure the following characteristics:

### For VCO evaluation

- RF power vs. tuning voltage
- Frequency vs. tuning voltage
- Tuning sensitivity
- Phase noise (Carrier-to-Noise)
- Harmonics
- FM deviation
- DC power consumption current

### For PLL evaluation

- RF power
- Phase noise (Carrier-to-Noise)
- Frequency and Frequency transient
- Spurious
- Harmonics

Each parameter can be measured without changing any cable connections. So, you can easily evaluate a VCO/PLL with powerful analysis functions such as marker or limit line.

## High Throughput and Easy Test Automation

Thanks to the high-speed phase noise measurement capability, it only takes about 2.5 seconds to measure five VCO parameters (RF power, frequency, phase noise, DC power consumption current and FM deviation) by using “VCO Tester” mode. The 4352S has the Instrument BASIC programming functions, built-in 3.5 inch disk drive (LIF/DOS format) and a 24-bit I/O. These capabilities allow you to interface to an automatic handler so that you can achieve automatic production-line testing without an external computer.

## Specifications Summary

### Source Characteristics

**DC Power Voltage:** 0 V to +15.5 V with 1 mV step, 50 mA max.

**DC Control Voltage:** 0 V to +20 V with 100  $\mu$ V step, 20 mA max.

**Option 001:** -15 V to +35 V

**Accuracy:**  $\pm$  (0.1% + 2 mV)

**Settling Time:** < 20 ms @ 0.1% error (typical)

**Noise Density:** < 1 nV/ $\sqrt$ Hz @ 10 kHz offset (typical)

**FM Signal:** 1 kHz, 0 to 1 Vrms with 1 mV step @ open load

### Receiver Characteristics

**Measurement Frequency Range:** 10 MHz to 3 GHz/12.6 GHz (with 43521A/refer to 43521A)/26 GHz (with 71707A/phase noise measurement only)

**Input Power Level:** -10 to +20 dBm

**Input Impedance:** 50  $\Omega$

**SWR:** < 1.2 (@ < 2 GHz); < 1.3

### RF Power Measurement

**Accuracy @ Peak Voltage Responding**  
 $\pm$  0.2 dB (@ 1 GHz, -5 dBm, typical);  $\pm$  1 dB

**Resolution:** 0.01 dB

### Frequency Measurement

**Frequency Resolution:** 1 kHz

### Frequency Transient Measurement

**Highest Accuracy:**  $\pm$  2 kHz

**Highest Measurement Resolution:** 50 Hz

**Maximum Sweep Time:** 10 sec.

**Minimum Time Resolution:** 12.5  $\mu$ sec.

### Phase Noise (Carrier-to-Noise Ratio) Measurement

**Offset Frequency Range:** 100 Hz to 10 MHz

### System Noise Level

Offset	Specification (dBc/Hz)	Typical (dBc/Hz)
100 Hz	-85	-90
1 kHz	-110	-117
10 kHz	-130	-137
100 kHz	-140	-147
1 MHz	-150	-157

### Spectrum Measurement

**Absolute Level Accuracy:** 2 dB (-5 dBm input, @ ATT=0 dB, typical)

**Relative Level Accuracy:** 0.5 dB (typical)

### FM Deviation Measurement

**Measurement Range:** 0 to 200 kHz (peak)

**Accuracy:**  $\pm$ (2% + 0.1% of measurement range) @ 1 kHz FM rate;  $\pm$  0.8% (typical)

**Residual FM:** < 3 Hzrms (@ 300 Hz - 3 kHz BW)

### DC Consumption Current Measurement

**Measurement Range:** 0 to 50 mA

**Accuracy:**  $\pm$ (0.2%  $\pm$  100  $\mu$ A)

### Storage

3.5-inch FDD: LIF/DOS format, 2DD/2HD

Internal RAM Disk: LIF/DOS format, 512 kB max.

### Interfaces

GPIB I/F, 24-bit parallel I/O I/F

## General Characteristics

**Display:** 8.5-inch color LCD

**Operating Temperature:** 0° C to +40° C

**Operating Humidity:** 15 to 95% RH

**Storage Temperature/Humidity:** 0 to +40° C/15 to 95% RH

**Power Requirements:** 90 to 132 V or 198 to 264 V, 47 to 66 Hz, 300 VA max.

**Size:** 235 mm H x 425 mm W x 553 mm D (9.4 in x 17 in x 22.12 in)

**Weight:** 21.5 kg (47.3 lb) (typical)

## Key Literature

Signal Generators RF and Microwave Models, p/n 5965-3094E

71707A Microwave Downconverter Technical Data, p/n 5091-4435E

## Ordering Information

**4352S** VCO/PLL Signal Test System

**4352B** VCO/PLL Signal Analyzer

**Opt 001** Expand DC Control Voltage

**Opt 1A2** Delete Keyboard

**43521A** Downconverter Unit

### Recommended Signal Generators

**8664A** Synthesized Signal Generator with Option 004

**8665A** Synthesized Signal Generator with Option 004

**8665B** Synthesized Signal Generator with Option 004

**8644B** Synthesized Signal Generator with Option 002

**E4425B** ESG-AP Signal Generator

**71707A** 26 GHz Microwave Downconverter

**70422A** 18 GHz Downconverter Module

See Signal Sources section for more details. When using the other signal generators, please contact the Agilent Call Center in your region for details.

43521A



43521A

## 43521A Downconverter Unit

The 43521A Downconverter Unit is designed to operate with the 4352S VCO/PLL signal test system. When configured with the 43521A downconverter unit, the 4352S offers a dedicated and comprehensive VCO/PLL design and production measurement solution for manufacturers that must test at frequencies above 3GHz. The enhanced 4352S is a complete system that offers a frequency range from 10MHz to 12.6GHz and is capable of measuring phase noise, RF power, lockup time, and many more parameters required for VCO/PLL evaluations.

### Specifications

#### RF-in Port:

**Connector:** N(f)  
**Frequency:** 10MHz to 12.6GHz

#### RF Power (Heterodyne Path):

**Input VSWR:** <1.5  
**Frequency:** 2.4GHz to 12.6GHz

#### Level:

**@ATT=0dB:** -20dBm to 0dBm  
**@ATT>0dB:** -20dBm to +20dBm

#### Resolution:

0.01 dBm

#### Accuracy: (@23° C±10° C)

##### @≤15dBm:

±1.5dB @≤4GHz  
±2.0dB @≤8GHz

±2.5dB @≤12.6GHz

##### @≤20dBm:

±1.5dB @≤4GHz(SPC\*)

±2.0dB @≤8GHz(SPC\*)

±2.5dB @≤12.6GHz(SPC\*)

**@-5dBm:** ±0.8dB @6GHz(Typical)

**@-5dBm:** ±1.0dB @12GHz(Typical)

#### Heterodyne Path Gain:

20dB @6GHz(SPC\*)

#### LO-in Port:

**Connector:** N(f)  
**Input Level:** +10dBm Nominal  
**Frequency Range:** 10MHz to 6GHz

#### LO-out Port:

**Connector:** N(f)  
**600MHz Output Level:** ≥+8dBm (SPC\*)  
**600MHz Accuracy:** 600MHz±50ppm (SPC\*)

#### Power Requirements:

90V to 132V or 198V to 264V, 47 to 63Hz, 100VA max

#### Size:

101 mm H x 425 mm W x 553mm D (4.04 in x 17 in x 22.12 in)

#### Weight:

8 kg (35.2 lb) (Typical)

\*SPC = Supplemental Performance Characteristics

### System Performance with 43521A

The system performance is the capacity achieved by the combination of the 4352B, the Signal Generator, and the 43521A when the 43521A is phase-locked to the 40 MHz on the 4352B. All data except for RF Power measurement are typical.

The operating frequency depends on the synthesized signal generator as follows.

Signal Generator	4352S Frequency Range
8664A	10MHz to 6.6GHz
8665A	10MHz to 9GHz
8665B	10MHz to 12.6GHz

#### Direct Path (10MHz to 3GHz)

**RF Power:** Add ±0.1dB to 4352B spec. (@≤2GHz)

Add ±0.2dB to 4352B spec. (@2GHz<Freq.≤3GHz)

**Other Parameters:** Same as the 4352B spec.

#### Heterodyne Path (2.4GHz to 12.6GHz)

##### Tester Mode

**RF Power:** Same as 43521A spec.

##### Frequency

**Frequency Range:** 2.4GHz to 12.6GHz

**Resolution:** Same as 4352B spec.

**Accuracy:** Same as 4352B spec.

##### FM Deviation

**Measurement Range:** Same as 4352B spec.

**Resolution:** Same as 4352B spec.

**Accuracy:** Same as 4352B spec.

##### Residual FM:

Same as 4352B spec.

##### Phase Noise: (C/N ratio [dBc/Hz])

**Offset Frequency Range:** 100Hz to 10MHz

##### Noise Floor:

(when equipped with the 8665B\*\* up to 12.6GHz)

≤6GHz when equipped with the 8664A\*\*

≤9GHz when equipped with the 8665A\*\*

\*\*with Opt 004

RF Freq.	Offset Frequency (Hz)				
	100	1k	10k	100k	1M
3GHz	-68	-93	-125	-137	-150
6GHz	-63	-88	-119	-131	-147
9GHz	-57	-84	-114	-125	-143
12GHz	-58	-81	-113	-125	-142

**Accuracy:** Same as 4352B spec.

#### Analyzer Mode

**RF Power:** Same as the 43521A spec.

**Frequency:** Same as the tester mode spec.

**Phase Noise: (C/N ratio)** Same as the tester mode spec.

#### Frequency Transient

**Frequency Range:** 2MHz, 20MHz, 512MHz

**Frequency Accuracy:** ±(Measurement Range x 0.1% + Time Base Accuracy of the External Signal Generator)

**Resolution:** 50Hz, 500Hz, 12.8kHz

#### Spectrum

**Absolute Accuracy:** ±3dBm@-10dBm, RF ATT=10dB

**Relative Accuracy:** Same as the 4352B spec.

### Ordering Information

#### 43521A Downconverter Unit

**Opt 1CM** Rackmount Kit

**Opt 1CN** Handle Kit

**Opt 1CP** Rackmount Kit & Handle Kit

**Opt ABA** English Localization

**Opt ABJ** Japanese Localization

**Opt OB0** Delete Operation Manual

**Opt OB1** Add Operation Manual

#### Recommended Signal Generators when configured with the 43521A

**8664A** Synthesized Signal Generator with Option 004

**8665A** Synthesized Signal Generator with Option 004

**8665B** Synthesized Signal Generator with Option 004



- 45 GHz solutions for millimeter wave module test
- Device test for LMDS, satellite antenna arrays, digital radio and T/R module manufacturing
- Excellent high frequency repeatability and correlation to benchtop measurements
- Enables fast time to market and low cost of test



E6520A

## High-Speed Test System for the Manufacturing Floor

### High Throughput Test for Microwave and Millimeter Wave Modules

In a manufacturing environment, high-test throughput is key to efficient volume production. Traditional “rack and stack” test systems, which are adequate for R&D characterization, fall short on the production floor where a large volume and/or mix of measurements or devices require full test plan execution within a few seconds. To address this need, Agilent has continued development of high-speed test platforms aimed at lowering the cost of test and reducing the time to market for device manufacturers.

### E6520A Millimeter Wave Module Test System

The E6520A series mm wave module test systems are designed for complete characterization of microwave and mm wave modules. The flexible architecture incorporates a high speed DSP based receiver with single-touch, multiple-measurement design. These hardware features are combined with user-friendly software to optimize the entire system for fast test plan execution.

### Software for Automated Testing

A key part of any high-throughput test system is the software. The software enables the user to quickly create or modify test plans and perform system calibrations. Fast test plan development reduces time to market by greatly limiting the amount of code generation necessary to test complex devices. Measurement path transforms and de-embedding insure the most accurate test results possible, and real time data recording allows viewing of data while the test plan is running. Industry standard data formats are available to insure a swift integration of the test solution to your production floor.

### Full Standard Measurement Capability

The E6520A mm wave module test system offers broad frequency coverage from 2 GHz to 45 GHz, a variable bandwidth DSP based receiver, two test ports, 1 watt power handling capability, four-2 amp power supplies and two synthesized sources.

Measurements included with standard system:

- S-Parameters, 1 or 2 port
- Power incident to, and out of DUT
- Gain, Gain Compression, Flatness
- Harmonics
- Known Spurs
- Voltage, Current
- Efficiency
- Test Time
- Combinations of the above measurements in the form of math blocks

Optional measurement capabilities:

- Additional test ports, up to a total of six ports (four 2 to 45 GHz ports and two 50 MHz to 3 GHz ports)
- Noise figure
- Mixer/converter measurements
- Two tone IMD
- Digital and analog DUT control

### A Modular, Reconfigurable Architecture

The E6520A uses industry-standard instrument and computer platforms to protect your investment. This allows quick and easy reconfiguration of stimulus and measurement resources to address different manufacturing test needs. Only Agilent’s high-speed test systems can deliver this kind of flexibility for both your present and future production test requirements.

### E6520A System Support Services

All E6520A test systems include a one-year, on-site worldwide warranty beginning at installation. Warranty services available include:

- Site preparation and installation
- 24 hour per day, 7 days per week phone support
- Next business day on-site response
- Access to regional shared spares
- Software updates (through the warranty period)
- System overview training
- On-line test plan development assistance
- Application phone and e-mail support

### Optional support services:

- On-site calibration services
- Hardware maintenance training
- On-site test plan development training
- On-site application consulting
- System Uptime Support Services
- Software Subscription Services

### Key Literature

E6520A Product Overview, p/n 5968-7842E  
 E6520A Configuration Guide, p/n 5968-8921E  
 E6520A Color Brochure, p/n 5968-6758E

### Ordering Information

Prices vary. For more information, please contact your Agilent sales representative (listed on page 563).

**Communications Signal Path Design Solutions**

Communications Design System Brochure  
High-Frequency Structure Simulator Rel 5.0

Technical Data Sheet

[5967-5846E](#)

85180A IC-CAP Modeling Suite

Release 5.0

[5965-7742E](#)

E8940A RF Designer

[5967-6013E](#)

High Frequency Structure Simulator

Optimizer

[5967-5594E](#)

Picosecond Interconnect Modeling Suite

Technical Data Sheet

[5964-2310E](#)

(PN 85150-2) Simulating Highly Nonlinear Circuits

[5091-8568E](#)

(PN E4600) Creating Measurement-Based

RFIC Models

[5965-7010E](#)

**EMI/EMC Test Systems**

Electromagnetic Compatibility 8590EM-1

[5964-2151E](#)

(PN 8566/B) Third Order Intermodulation

Distortion Measurements

[5954-2701](#)

**Signals Development & Intercept Solutions**

3587S Signal Analysis, Opt ATR, Product

Overview

[5964-3631E](#)

E3238 Signals Development System Video

[5968-3571E/PAL/SECAM](#)

WJ9119 VXI HF Tuner, Technical Specifications

[5966-2298E](#)

**Overview** 348

*See also*  
Frequency & Time Standards 504

**Digital Microwave Radio  
Test Equipment** 352

**Wireless Mobile & Base  
Station Test Sets** 353

**Cellular/PCS Transmitter &  
Receiver Test Equipment** 379

*See also*  
Modulation Domain Analyzers 132  
Signal Analyzers 227

**Wireless Network  
Air Interface Testing** 392

**Pager Test Equipment** 395

**Additional Literature** 397

**Agilent is dedicated to helping you achieve success with your wireless appliances and services.**

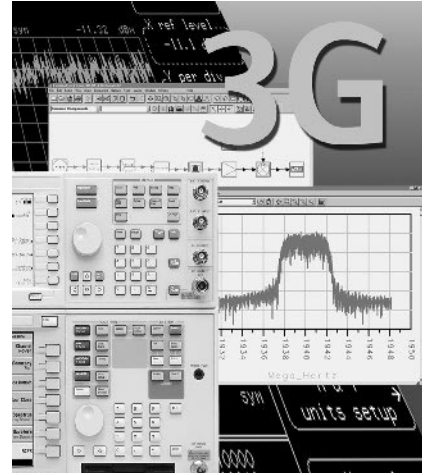

**We join you in the challenge of building the next generation of wireless communications.**

Today, the expansive proliferation of wireless devices and applications is incredibly dynamic. Not so long ago, most of us knew someone who owned a cell phone, now most of us have one of our own—in addition to other wireless devices that have become part of our daily lives. Personal digital appliances (PDAs), pagers, GPS systems, and cell phones are all examples of how wireless technology is bringing information and communications to our fingertips whether we're at home or on the go.

In parallel, the Internet is a pervasive part of our home, school, and business lives. Broadband wireless access technologies are among the many new choices being deployed to make that "last mile" connection.

The possibilities for the next generation of wireless applications are exciting and limitless. However, for the engineer, designing, producing and providing services for all these applications and infrastructure components, there are high degrees of uncertainty and numerous challenges to overcome. Whether your particular challenge is to be first to design a new wireless phone, base station, or component, to ramp up a production line to full volume, or to ensure that there are no holes in your network, Agilent Technologies has products, services, and solutions to meet your needs.





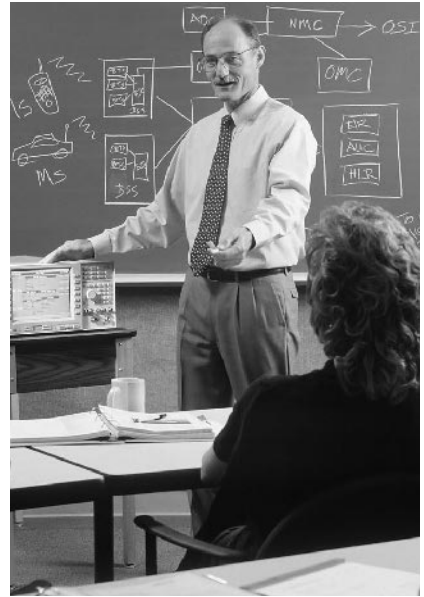

**We work across the delivery chain from R&D through manufacturing, installation, maintenance, and repair.**

Agilent Technologies has the industry's broadest test and measurement instrumentation offering, as well as worldwide services and support. Our test and measurement products for wireless applications span design tools, network analyzers, signal sources, signal analyzers, inspection systems, test sets, and test systems. These tools cover a wide range of digital and analog formats. They can be used to perform numerous measurements and have applications from R&D, through manufacturing, installation, maintenance, and repair.

Our goal is to support you in overcoming wireless test and measurement challenges today and tomorrow by building test and measurement equipment based on the latest technologies, by programming standards compliance into the measurements, and ultimately by leveraging our industry knowledge into tools, training, services, and support.

**A resource you can count on.**

Agilent engineers and members of the management team participate on communications standards committees. This keeps us current on industry developments, so you can be confident that our products reflect the latest changes in the evolution of wireless standards. Our involvement with the standards committees allows us to share knowledge with you, as you consider which future technologies, standards, and protocols will lead to your company's success.

We share our broad technology understanding in several ways such as newsletters, application and product notes, symposia, conferences, consulting, and training and tutorial services. For specifics on events and literature, please refer to the Agilent wireless-focused information on our web site:

**[www.agilent.com/find/wireless](http://www.agilent.com/find/wireless)**

**Use the table on the following pages to find the Agilent products best suited to help you meet your test and measurement challenges.**

Please, take a moment to peruse the selection guide on the following pages. Chances are, we have solutions in the form of both products and services for the problems that you are facing today. The information in the table includes only some of what Agilent can offer. If you don't see your specific system or measurement challenge referenced on the tables, please contact your Agilent Field Engineer or the Agilent Call Center for personal analysis, support, and recommendations. We would like to have the opportunity to work with you in finding the unique solution for your wireless product development, production, or service and support challenge.

### Legend

- 1 Supports FLEX, FLEX-TD, and PCSAG
- 2 8920 does LTR, MPT 1327, and EDACS formats
- 3 RF source only, analog only
- 4 Available with TDMA only
- 5 Applicable to these design areas

### Products

	Digital Systems														Analog Systems												
	3GPP W-CDMA	Bluetooth	CDMA	CDMA (PCS)	cdma2000 (IS-2000)	CDPD	CT2-CA1	CT3	DCS 1800	DECT	EDGE	GSM 900	PCS 1900	PDC	PHS	TDMA (NADC)	TDMA (NADC) PCS	TETRA	AM	AMPS	FM/PM	JTACS	NAMPS	NMT 450/900	NTACS	TACS/ETACS	TRUNKING
3272 Series 3 Process Test System	•		•	•	•	•	•	•	•	•	•	•	•	•	•	•	•	•	•	•	•	•	•	•	•	•	•
4291B, E4991A RF Impedance/Material Analyzer																											
4287A RF LCR Meter																											
4396B Network/Spectrum /Impedance Analyzer																											
53140, 53150 Series Microwave Counters																											
53310A Modulation Domain Analyzer						•	•	•	•	•	•	•	•	•	•	•	•	•			•						
5DX X-RAY Inspection System																											
66300 Series Mobile Communications dc Sources	•		•	•	•				•	•	•	•	•	•	•	•	•	•	•	•	•	•	•	•	•	•	•
84000 Series RFIC Test System	•		•	•	•	•	•	•	•	•	•	•	•	•	•	•	•	•	•	•	•	•	•	•	•	•	•
8560 E-Series Portable Spectrum Analyzers																				•	•						
8590 E-Series Portable Spectrum Analyzers		•	•	•			•	•	•	•	•	•	•	•	•	•	•	•		•	•						
8648A Opt 1EP Signal Generator (Pager Test) <sup>1</sup>																				•	•						
8648 and ESG-A/AP Series Analog Signal Generators																				•	•						
8712/14/53, E8356A/57A/58A RF Vector Network Analyzers																											
8720 Microwave Vector Network Analyzer																											
8643/44/62/63/64/65 Signal Generators																				•	•	•	•	•	•	•	•
8920A/B/DT RF Communications Test Set														•	•	•	•	•	•	•	•	•	•	•	•	•	2
8921A Cell Site Test Set			•			•										•	•	•	•	•	•	•	•	•	•	•	•
8922M/P GSM Mobile Test Set								•			•	•															
8924E CDMA Mobile Station Service Test Set			•	•																•	•	•	•	•	•	•	•
8935 Series Base Station Test Sets (CDMA or TDMA)			•	•		4		•			•	•				•	•			•	•	•	•	•	•	•	•
89400 Series Vector Signal Analyzers	•	•	•	•	•	•	•	•	•	•	•	•	•	•	•	•	•	•	•	•	•	•	•	•	•	•	•
89600 Series Vector Signal Analyzers		•	•	•	•	•	•	•	•	•	•	•	•	•	•	•	•	•	•	•	•	•	•	•	•	•	•
8960 Series 10 Wireless Comm. Test Set								•	•		•	•				•	•			•							
Advanced Design System	•	•	•	•	5	•	•	•	•	•	•	•	•	•	•	•	•	•	•	•	•	•	•	•	•	•	•
BV3000 Automated Optical Inspection System																											
E4406A VSA Transmitter Tester	•	•	•	•	•			•			•	•	•			•	•						•				
E4594A, E6323A/25A/49A, T1/E1 Test Advisor	•	•	•	•	•	•	•	•	•	•	•	•	•	•	•	•	•	•	•	•	•	•	•	•	•	•	•
E6392A GSM Mobile Station Test Set								•			•																
E7400 Series Drive Test System	•	•	•	•				•			•	•				•	•	•		•							
E7580A ProBER 2, 2 Mb/s Handheld Test Set																											
E8285A CDMA Mobile Station Test Set			•																		•	•	•	•	•	•	•
EPM, EPM-P Series Power Meters (sensor dependent)	•		•	•	•	•	•	•	•	•	•	•	•	•	•	•	•	•	•	•	•	•	•	•	•	•	•
ESA-E Series Portable Spectrum Analyzers			•	•	•			•	•	•	•	•								•	•						
ESG-D/DP Series Digital Signal Generators	•	•	•	•	•			•	•	•	•	•	•	•	•	•	•	•	•	•	•						
N1610A/60A Dual DS1/0 Service Advisor Tester Tablet	•		•	•	•	•	•	•	•	•	•	•	•	•	•	•	•	•	•	•	•	•	•	•	•	•	•
N1725A/26A auroraDuet ISDN/BER Tester	•		•	•	•	•	•	•	•	•	•	•	•	•	•	•	•	•	•	•	•	•	•	•	•	•	•
N1735A auroraTempo Frame Relay/BER Tester	•		•	•	•	•	•	•	•	•	•	•	•	•	•	•	•	•	•	•	•	•	•	•	•	•	•
TS-5500 GSM/CDMA Cellular Phone Funct. Test Platform			•	•				•			•	•															
Test Fixtures	•	•	•	•	•	•	•	•	•	•	•	•	•	•	•	•	•	•	•	•	•	•	•	•	•	•	•

# Wireless Communications Instruments & Systems

## Table of Products versus Systems and Measurements (cont.)

Measurements																							
Battery Simulators	Call Processing	Current Draw	Design & Simulation	Device Trans./Reflec.	Device Complex Imp.	Device Group Delay	Fading Simulation	Functional Test	In-Circuit Test	T1/E1 Circuit Test	Receiver Out-of-Chan.	Receiver In-Channel	Signaling/Protocol	Spectrum Analysis	Spectrum Monitoring	Transmitter Power	Transmitter Frequency	TX Modulation	TX Amplitude	R&D	Manufacturing	Installation	Service & Repair
										•										•			3272 Series 3 Process Test System
					•															•	•		4291B, E4991A RF Impedance/Material Analyzer
					•															•	•		4287A RF LCR Meter
				•	•	•								•		•			•	•	•		4396B Network/Spectrum /Impedance Analyzer
																•	•			•	•	•	53140, 53150 Series Microwave Counters
				•		•		•			•	•						•		•	•	•	53310A Modulation Domain Analyzer
																					•		5DX X-RAY Inspection System
•		•	•					•												•	•	•	66300 Series Mobile Communications dc Sources
		•		•	•						•	•		•		•				•	•		84000 Series RFIC Test System
			•	•				•						•	•	•	•		•	•	•	•	8560 E-Series Portable Spectrum Analyzers
				•				•	•		•	•		•	•	•	•	•	•	•	•	•	8590 E-Series Portable Spectrum Analyzers
								•												•	•		8648A Opt 1EP Signal Generator (Pager Test) <sup>1</sup>
																				•	•	•	8648 and ESG-A/AP Series Analog Signal Generators
				•	•	•														•	•	•	8712/14/53, E8356A/57A/58A RF Vector Network Analyzers
				•	•	•														•	•		8720 Microwave Vector Network Analyzers
										3	3									•	•		8643/44/62/63/64/65 Signal Generators
	•							•		•	•		•		•	•	•	•	•	•	•	•	8920A/B/DT RF Communications Test Set
								•		•	•		•		•	•	•	•	•	•	•	•	8921A Cell Site Test Set
	•							•		•	•		•		•	•	•	•	•	•	•	•	8922M/P GSM Mobile Test Set
	•							•		•	•		•		•	•	•	•	•			•	8924E CDMA Mobile Station Service Test Set
								•		•	•		•		•	•	•	•	•	•	•	•	8935 Series Base Station Test Sets (CDMA or TDMA)
														•		•	•	•	•	•	•	•	89400 Series Vector Signal Analyzers
														•		•	•	•	•	•	•	•	89600 Series Vector Signal Analyzers
	•							•			•					•	•	•	•	•	•	•	8960 Series 10 Wireless Comm. Test Set
			•																	•			Advanced Design System
																				•			BV3000 Automated Optical Inspection System
														•		•	•	•	•	•	•	•	E4406A VSA Transmitter Tester
									•												•		E4594A, E6323A/25A/49A, T1/E1 Test Advisor
	•	•						•			•			•	•	•	•	•	•			•	E6392A GSM Mobile Station Test Set
	•												•	•	•	•	•	•	•			•	E7400 Series Drive Test System
									•												•		E7580A ProBER 2, 2 Mb/s Handheld Test Set
	•	•						•	•		•		•		•	•	•	•	•	•	•	•	E8285A CDMA Mobile Station Test Set
																•				•	•	•	EPM, EPM-P Series Power Meters (sensor dependent)
			•	•				•	•		•	•		•	•	•	•	•	•	•	•	•	ESA-E Series Portable Spectrum Analyzers
											•	•								•	•	•	ESG-D/DP Series Digital Signal Generators
	•								•												•		N1610A/60A Dual DS1/0 Service Advisor Tester Tablet
	•								•													•	N1725A/26A auroraDuet ISDN/BER Tester
									•													•	N1735A auroraTempo Frame Relay/BER Tester
	•							•		•	•			•		•	•	•	•	•	•	•	TS-5500 GSM/CDMA Cellular Phone Funct. Test Platform
																				•			Test Fixtures

# Digital Microwave Radio Test Equipment

352

## Digital Radio Test System/Group Delay and Amplitude Flatness/Multipath Fading Simulator

11758V  
11770A  
11757B

- Performs important installation and maintenance measurements
- Easy to use
- Portable and rugged construction
- Group delay and amplitude flatness measurement option
- An economical way to add high-performance, end-to-end group delay measurements to your spectrum analyzer
- Ideal for digital radio, satellite, and cable testing
- Measures any two-port device between 300 kHz and 2.9 GHz

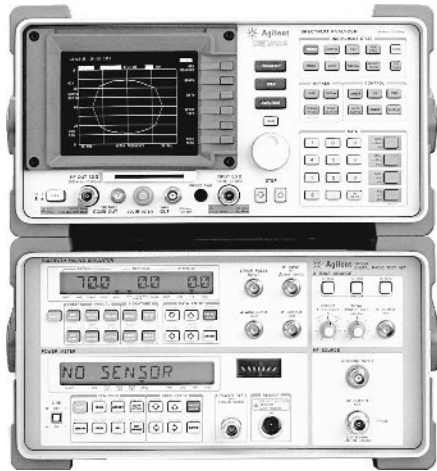

11758V

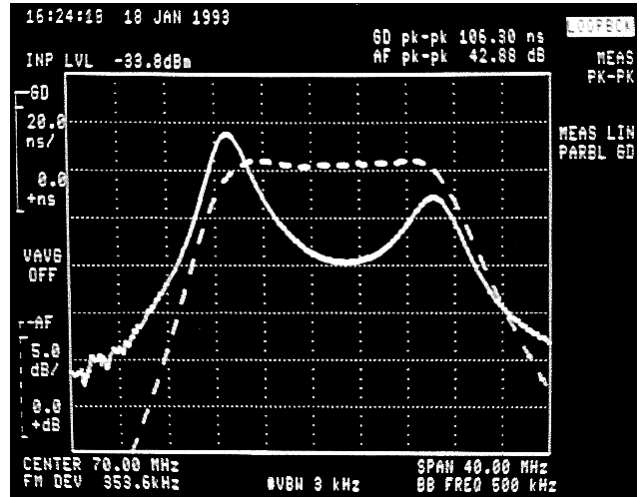

### 11758V Digital Radio Test System



The 11758V combines several popular Agilent instruments into one portable system. This combination provides you with an all-in-one portable system that is ideal for the installation and maintenance of microwave radios, and is especially suitable for work in rugged terrain or remote areas.

The 11758V can be configured to have all your necessary measurement functions available during radio installation and maintenance. The spectrum analyzer can even control other GPIB instruments to automate measurements for quicker and more reliable results.

#### Test Functions

- Spectrum Analysis:** 50 kHz to 22 GHz (26 GHz optional)
- Swept Source:** 300 kHz to 2.9 GHz (options to 24 GHz)
- Group Delay and Amplitude Flatness:** 300 kHz to RF source maximum frequency (Option 201)
- Multipath Signature Test Set:** 40 MHz to 90 MHz (options to 190 MHz)
- Power Meter:** 10 MHz to 18 GHz (options to 26 GHz)
- Frequency Counter:** 50 kHz to 22 GHz (options to 26 GHz)
- Intermodulation Test Signal:** 70 and 140 MHz bands available and more

#### Key Literature

11758V Digital Radio Test System, Data Sheet, p/n 5091-4651E

### 11757B Multipath Fading Simulator/Signature Test Set

- Automatic multipath signature measurements
- Measures and prints static M-curves, dynamic M- and S-curves, recovery signatures, recovery times, and dispersive fade margin
- High-performance, lightweight, and economical

The 11757B characterizes the equalizers in modern digital microwave radios by introducing a precisely-controlled notch in and around the radio's transmission bandwidth. This allows precise measurements of the equalizers' ability to compensate for multipath fading. The 11757B records the measurement automatically on a built-in printer.

#### Key Literature

11757B Multipath Fading Simulator/Signature Test Set, Data Sheet, p/n 5091-1052EN/EUS  
Application Note 355-1, Tools for Digital Microwave Radio Installation and Maintenance, p/n 5962-9920E

### 11770A Link Measurement Personality

Accurately-adjusted group delay and amplitude flatness is critical to the proper performance of virtually every wideband digital or analog communication network. The 11770A link measurement personality adds group delay and amplitude flatness measurement capabilities to the 11758V, with Option 201, (or to an 8593E/94E/95E/96E spectrum analyzer configured with Option 111 group delay and amplitude flatness plus tracking generator). This makes it ideal for testing digital and analog terrestrial radios as well as other broadcast and transmission media like satellite and cable networks.

When this personality is installed in a spectrum analyzer, the 11770A is far more portable than any previous solution that makes the same group delay and amplitude flatness measurements, plus it maintains the ease-of-use features you expect from standalone test equipment. This measurement configuration also provides important link analysis functions at a significantly lower cost when compared to using separate pieces of test equipment. DADE and return loss measurements can also be made with the optional switch and bridge.

#### Key Literature

11770A Link Measurement Personality, Data Sheet, p/n 5091-4652E





8920A

### 8920A RF Communications Test Set

The 8920A is a full-feature, one-box test set designed to meet service and repair needs in the cellular and land mobile communications market. Combining 22 instruments, the 8920A offers full functionality needed in testing cellular phones, land mobile radios, and communications systems up to 1 GHz. Additionally, with the new standard electronic attenuator, the reliability of the 8920A has been increased to help guarantee the maximum effective usage of the test set.

#### Test and Troubleshoot Faster

The 8920A decreases test and troubleshooting time by simplifying standard measurement tasks and providing extensive capability in one box. Transmitters and receivers are simply characterized with single-key RX, TX, and duplex tests. Measured results are displayed on a single screen as either digital measurements or analog bar graphs. All settings and measurements are easily accessed and changed using the front-panel knob, and all settings can be saved in nonvolatile save/recall registers or on a SRAM card media for future access.

#### Spectrum Analyzer with Tracking Generator and Adjacent Channel Power

The 8920A's optional synthesized spectrum analyzer measures signals from 10 MHz to 1 GHz with variable spans from 5 kHz to 1 GHz (full span). Display resolution is selectable from 1, 2, or 10 dB per division. The tuneable marker provides automatic readout of frequency and amplitude, or of relative frequency or amplitude from a reference. The tracking generator included with the spectrum analyzer allows for swept characterization of devices with fully settable amplitude and sweep spans (to 1 GHz). The adjacent channel power measurement capability includes both variable bandwidths and variable frequency offsets. Typical performance is  $-70$  dBc.

#### Signaling Encoder and Decoder

The optional signaling encoder and decoder support all common signaling formats, including tone sequential, digital paging, DTMF, trunking, and cellular signaling. Common standards are list-selectable and easily modified for different user formats. The decoder displays the tone or digital sequence transmitted, and the duration of the tone or tone pair. For digital paging transmitters, the decoder will display the address/code, the message, and the transmission rate.

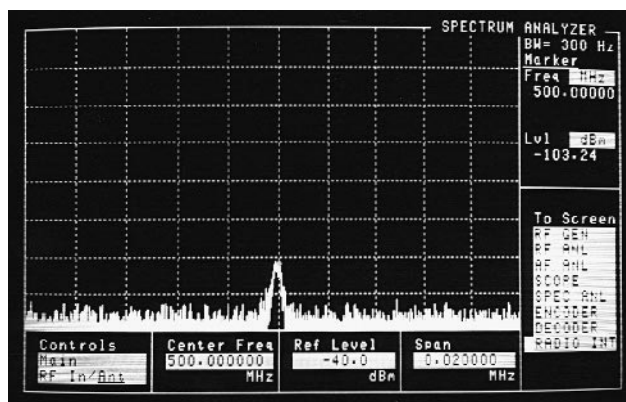

8920A Spectrum Analyzer displaying signal at  $-103.2$  dBm ( $1.54$   $\mu$ V). Sensitive Receiver:  $2$   $\mu$ V sensitivity (typically  $< 1$   $\mu$ V), available through the ANT IN port, allows for off-the-air monitoring of low-level signals. For measuring high-power signals, the 8920A can accept 100 W intermittently (for 10 seconds) or 60 W continuous.

### 11807A Radio Test Software

The 11807A is an easy-to-use software solution for automatic testing of radio receivers and transmitters. Running on the 8920A's built-in IBASIC computer, the 11807A offers a selection of tests for land mobile radios, cellular phones, and communication systems. Its flexibility and modularity allows the user to select and change test sequences, test parameters, and pass/fail limits without programming expertise. All test results are displayed on the screen and can be documented with hard-copy printouts when an external printer is added.

The 11807A system support tests (Option 100) give technicians automated test capability for commonly performed tasks on communications systems. System support tests include cable-fault location, intermodulation-products calculation, frequency scanning, field-strength measurement, and automated save/recall of instrument settings.

#### International Cellular Phone Testing Solutions

The 8920A is capable of testing the world's most common cellular phones by using the 11807A radio test software. Three levels of testing are available: manual phone troubleshooting, quick functional checkout, and full parametric testing to system specifications. Cellular formats supported include AMPS, TACS, and JTACS. 8920A Option 004 is required for cellular phone tests with 11807A software.

#### Trunked Radio Testing

An 11807A software option is available for testing trunked mobile radios. The option supports EDACS trunked radio equipment with a variety of automated tests available to the user.

Through software control, the 8920A will test the ability of a radio to establish a link on a trunked system and can retrieve trunking parameters programmed into a mobile radio. The user can choose from manual operations or automated test sequences for full characterization. Detailed printouts of the radio's performance, with failures highlighted, are output when a printer is used with the 8920A. (8920A Option 103 is required for printouts.)

8920A Option 004 is required for trunked system tests with 11807A software.

#### Key Literature

8920A Product Overview, p/n 5968-5386E  
 8920A Price List, p/n 5968-5387EUS  
 11807A/E Product Overview, p/n 5968-1379E  
 Service Applications/Brochure, p/n 5952-2795

8920B  
11807A/E  
83206A  
83236B  
8920B  
Opt 800  
Opt 801

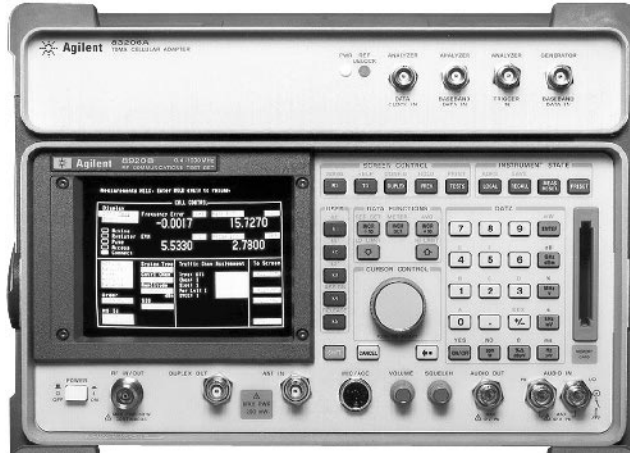

8920B Option 800

## 8920B RF Communications Test Set



The 8920B is a full-function test set based upon the 8920A design but with increased measurement speed, accuracy, and larger user memory (928 kbytes standard). The 8920B uses PCMCIA memory cards for data storage and radio test programs. The 8920B has the functionality, speed, and accuracy for testing land mobile radios, cellular telephones and other communications systems while improving throughput and quality in manufacturing.

### 8920B Option 800 – 83206A TDMA Cellular Adapter

The 83206A TDMA cellular adapter (8920B Option 800) provides a complete  $\pi/4$  DQPSK signal generator,  $\pi/4$  DQPSK modulation analyzer, data source, and BER/WER analyzer for TDMA measurements on DAMPS (IS-54) and DCCH (TIA/EIA-136) phones. The 83206A supersedes the 83201B TDMA cellular adapter (8920B Option 500) for making measurements on TDMA dual-mode DAMPS phones, adding digital control channel test features to fully characterize DCCH phones. This option replaces the 8920D for TDMA mobile test.

### 8920B Option 801 – 83236B PCS Interface

Extend DCCH test capabilities for PCS (1900 MHz) phone test by adding the 83236B PCS interface to translate DCCH measurement capability to the International and U.S. PCS bands. Power measurement accuracy and speed are maintained at PCS band frequencies with an internal power meter for measurements on CW and TDMA ( $\pi/4$  pulsed or continuous) signals. 8920B Option 801 is an order convenience option that includes the three units needed for PCS mobiles using TIA/EIA-136 format. Includes: 83206A and 83236B host firmware integrates the functions of these three units. Also order Options 001, 004, 006, 051, with Option 800 to do TIA/EIA-136 TDMA mobile test.

### The 8920B Increases Throughput

The 8920B combines a faster processor, increased user memory, and other features to gain measurement speed over standard GPIB instruments and the 8920A.

#### Test Time Execution Comparison

8920B compared to:	Typical test time decrease
Stand alone GPIB instruments	15%
8920A with internal IBASIC programs	30%
8920A program load from memory cards	90%

## 8920B Has High Performance and Accuracy as Standard Features

Along with speed enhancements, the 8920B has signal generator level accuracy of  $\pm 1$  dB at the duplex port and power measurement accuracy of  $\pm 5\%$  for levels from 1 mW to 60 watts at the RF In/Out port. Residual FM is less than 7 Hz rms, CCITT. For audio tests, the variable frequency notch filter from 300 Hz to 10 kHz is standard. The FM deviation accuracy is 3.5% and FM distortion less than 0.5%. GPIB, RS-232, and Centronics ports are standard.

## Call Processing

Front-panel screens simplify manual testing as well as GPIB programmability. In call-processing mode, the 8920B emulates a cellular base station, allowing you to automatically establish and maintain a cellular link between the test set and cellular phone. Use the front-panel knob to register the phone, originate a call, page the phone, hand-off to other channels, change power and release calls as well as make fast parametric measurements while the phone is on an analog voice or a digital traffic channel.

## Easier Programming

The call-processing subsystem also creates a more user-friendly programming interface for automated cellular phone test. High-level GPIB commands such as “page” and “register” simplify code generation for phone test. Agilent VEE programmers will also benefit with the addition of 8920B-Agilent VEE drivers.

## 11807E Radio Test Software

The 11807E radio test software family offers easy-to-use software programs for automatic testing of radio receivers and transmitters. The 11807E software family is the same set of tests as included in the 11807A family, but on PCMCIA cards to work with the 8920B. A complete selection of tests are available for land mobile radios, cellular telephones, and trunked radio communications systems. The new Option 024 software package is available to test cellular on PCS mobiles using AMPS, NAMPS, DAMPS, and DCCH/PCS formats.

## Cellular Telephone and Trunked Radio Testing

The 8920B is capable of testing many of the world’s analog cellular and trunked radio systems using the software packages in the 11807E family. Cellular systems include: AMPS/EAMPS/NAMPS, TACS/ ETACS, JTACS/NTACS, and NADC-TDMA dual-mode, both DAMPS (IS-54) and DCCH (TIA/EIA-136). The trunked radio system package is EDACS, FM tests included.

## Flash ROM Makes Firmware Upgrades Simpler

The 8920B firmware is contained in Flash ROM which can be upgraded via a PCMCIA card from the front panel in just minutes. The upgrade card can be reused. This helps maintain better process control on your production line by keeping the latest firmware version current with minimum downtime. One card upgrades the 8920B host, but a full digital upgrade requires a card set.

## Key Literature

- 8920B Brochure, p/n 5968-5921E
- 8920B Technical Specifications, p/n 5968-1376E
- 8920B Configuration Guide, p/n 5968-5919E
- 8920B Price List, p/n 5968-5920EUS
- 11807A/E Product Overview, p/n 5968-1379E

### Ordering Information

- 8920A** RF Communications Test Set
  - Opt 001** High-Stability Timebase
  - Opt 004** Tone/Digital Signaling
  - Opt 007** Low-Level RF Power Measurement
  - Opt 008** Cellular Mobile RF Power Measuring Range
  - Opt 010** 400 Hz High-Pass Filter
  - Opt 011** CCITT Weighting Filter
  - Opt 012** 4 kHz Bandpass Filter
  - Opt 013** C-Message Weighting Filter
  - Opt 014** 6 kHz Bandpass Filter
  - Opt 016** High power input option: 100 watts
  - Opt 019** Variable Frequency Notch Filter
  - Opt 020** Radio Interface Card
  - Opt 050** Dual-Mode Rear-Panel Connectors
  - Opt 055** Mechanical Attenuator Input Option
  - Opt 102** Spectrum Analyzer with Tracking Generator and ACP
  - Opt 103** GPIB/RS-232/Parallel dc Current Measurement
- 11807A** Radio Test Software
  - Opt 001** North American FM Tests
  - Opt 003** AM Tests
  - Opt 004** AMPS/EAMPS/NAMPS Cellular Tests
  - Opt 005** TACS/ETACS/NTACS Cellular Tests
  - Opt 011** EDACS Trunked Radio Tests
  - Opt 100** System Support Tests
- 8920B** RF Communications Test Set
  - Opt 001** High-Stability Time Base
  - Opt 004** Tone/Digital Signaling
  - Opt 006** 10 W to 50  $\mu$ W Power Measurement Range
  - Opt 007** Low-Level RF Power Measurements
  - Opt 010** 400 Hz High-Pass Filter
  - Opt 011** CCITT Weighting Filter
  - Opt 012** 4 kHz Bandpass Filter

- Opt 013** C-Message Weighting Filter 8920A
- Opt 014** 6 kHz Bandpass Filter 8920B
- Opt 016** High Power Input Option: 100 Watts 8920DT
- Opt 020** Radio Interface Card 83201B
- Opt 031** Delete Handle and Cover 83206A
- Opt 051** Dual-mode Rear-Panel Connectors 83236B
- Opt 055** Mechanical Attenuator Input Option 11807A
- Opt 102** Spectrum Analyzer with Tracking Generator and ACP 11807E
- Opt 800** 83206A TIA/EIA-136 TDMA Cellular Adapter
- Opt 801** Adds 83206A and 83236B for EIA/TIA-136 Tests
- Opt 1CM** Rackmount Kit Without Handle
- Opt AXK** Rackmount Kit with Option 500 or 800
- Opt 080** Delete Manual Set
- 83206A** TIA/EIA-136 TDMA Cellular Adapter
- 83236B** PCS Interface
  - Opt AX4** Rack Flange Kit Without Handles
- 11807E** PCMCIA Radio Test Software for 8920B
  - Opt 001** North American FM Tests
  - Opt 003** AM Tests
  - Opt 004** AMPS/EAMPS/NAMPS Cellular Tests
  - Opt 005** TACS/ETACS Cellular Phone Tests
  - Opt 011** EDACS Trunked Radio Tests
  - Opt 014** AMPS/NAMPS/DAMPS/DCCH Dual-Mode TDMA Cellular Phones
  - Opt 024** AMPS/NAMPS/DAMPS and DCCH/PCS TMDA Cellular Phones
  - Opt 100** System Support Tests

Some of the following additional instruments may be necessary to perform some tests:

- 8595E** Spectrum Analyzer
- 34401A** Digital Multimeter
- ESG-D300A** E4432AR Digital and Analog Signal Generator
- 8643A** Synthesized Signal Generator
- 6642A** or **6643A** DC Power Supply

 Indicates QuickShip availability.



8921A



8921A

## 8921A Cell Site Test Set



The 8921A cell site test set is a highly-portable, integrated solution for the installation and maintenance of AMPS and TACS cell sites and is upgradable to test CDPD, CDMA, and TDMA systems. The 8921A incorporates more than twenty powerful instruments into a compact, 38-pound package. The integral IBASIC controller in the 8921A runs the 11807B cell site test software to fully automate base station test and adjustment procedures. Automation combined with accurate measurements increases technician efficiency to speed installation and maintenance procedures.

### 8921A Features Summary

- AM/FM signal generator
- AM/FM modulation analyzer
- Duplex offset generator
- RF power meter
- RF frequency counter/frequency error meter
- Audio frequency counter and power meter
- AC/DC voltmeter
- SINAD/SNR/distortion meter
- Two variable frequency AF generators
- Digital oscilloscope
- Built-in IBASIC controller
- Spectrum analyzer with tracking generator
- Adjacent channel power meter
- Signaling encoder and decoder
- High-stability timebase
- DC current meter
- GPIB/RS-232/parallel remote interfaces
- Upgradability to TDMA, CDMA, or CDPD
- Optional cellular base station test software
- Optional radio interface card
- Optional Ericsson PCM reference

### Upgrading for New Formats

Beyond testing analog AMPS and TACS base stations, the 8921A is ready to grow with your measurement needs for digital cellular systems with upgrades available for:

- TDMA
- CDMA
- CDPD

### High-Performance Spectrum Analyzer

The spectrum analyzer of the 8921A has the wide dynamic range and synthesized frequency accuracy previously found only in expensive standalone spectrum analyzers. Wide dynamic range allows the 8921A to locate low level signals in the presence of high power transmitters. Synthesized frequency accuracy translates into high confidence that you've located the correct signals.

With frequency spans ranging from 1 GHz to as narrow as 5 kHz, the 8921A has the flexibility to look at the entire RF spectrum and then zoom in on the desired signals. The marker function displays the frequency and amplitude of any displayed signal. The marker-to-peak function displays the frequency and amplitude of the largest on-screen signal with a single keystroke.

### Built-in Tracking Generator

The 8921A spectrum analyzer also includes a built-in tracking generator for tuning base station duplexers. With +11 std dBm power output (over range), use the tracking generator as an input stimulus to the duplexer. The calibrated level of the spectrum analyzer ensures accurate adjustment of duplexers. Using the marker function of the spectrum analyzer, the rejection of the duplexer can be measured at any point of the filter response. Antenna return loss can be quickly and accurately measured onsite with the 8921A tracking generator. Using the tracking generator to drive the antenna through an external VSWR bridge, the reflected power can be measured on the 8921A spectrum analyzer. Other measurements performed with the tracking generator include insertion loss and frequency response of filters, cables, or attenuators. The tracking generator features calibrated output level from -137 to +5 std dBm and variable frequency offset for IF to RF conversion measurements. Coupled with 1, 2, and 10 dB per division spectrum analyzer ranges, normalization, and marker capability, the tracking generator makes the 8921A ideal for all types of measurements and adjustments.



### Automated Base Station Maintenance

For complex base station maintenance, the 11807B cell site test software, running on the 8921A's internal controller, guides the user through each step of the procedure. Graphical displays show connection diagrams and highlight key adjustment points when required. Technicians spend less time learning and more time testing with the 8921A cell site test set.





8921A Option 600, 602, 603

### 8921A Option 600, 602, 603 CDMA/CDPD Cell Site Test System



Option 600 (or 603) for the 8921A adds the 83205A Option 001 (or 003) CDMA cellular adapter to the cell site test set to provide testing of CDMA (IS-95A and IS-97) base station equipment. This system provides signal generation and analysis of QPSK/OQPSK signals. The system measures power in each Walsh-coded signal, code channel timing, and code channel phase relative to the pilot.

The 83205A Option 002 (or 003) CDPD test option quickly and accurately tests key RF parameters on both the forward-channel transmitter and the reverse-channel receiver. CDPD software, included with all CDPD hardware, automates transmitter, receiver, and system tests—making it easy to standardize system maintenance with fast and accurate test procedures.

#### 8921A Option 600/603 Features Summary

All 8921A standard features, plus:

- Measurements of waveform quality “ρ” (rho), frequency error, time offset, and carrier feedthrough
- Code domain power, timing, and phase analysis
- Average power and CDMA channel power measurements
- CDMA QPSK/OQPSK RF source with data buffer and IS-95 reverse link coding
- Built-in AWGN (Added White Gaussian Noise) source for calibrated E<sub>b</sub>/N<sub>0</sub> settings
- Includes both 14.4 and 9.6 Kbps vocoder rate sets

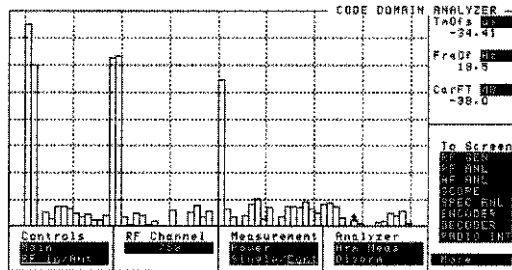

#### 83205A CDMA/CDPD Cellular Adapter

For those who already own 8921As, the 83205A Option 003 CDMA/CDPD cellular adapter can be added to upgrade the unit to perform the CDMA/CDPD tests described above for the 8921A. Note: Older 8921As may require an upgrade for complete CDMA capabilities.



8921A Option 500, 502, 503

### 8921A Option 500, 502, 503 TDMA/CDPD Cell Site Test System

The 8921A Option 500 (or 503) adds the 83204A to the 8921A to provide testing of TDMA (IS-136) base station equipment. This unit adds  $\pi/4$  DQPSK signal generation and analysis to the powerful analog features of the standard 8921A. A custom screen provides control of the TDMA source and provides selection of several measurement modes, making all test results visible in one place.

The 83204A CDPD (Option 002 or 003) test option quickly and accurately tests key RF parameters on both the forward-channel transmitter and the reverse-channel receiver. CDPD software, included with all CDPD hardware, automates transmitter, receiver, and system tests—making it easy to standardize system maintenance with fast and accurate test procedures.

#### 8921A Option 500 Features Summary

All 8921A standard features, plus:

- Measurements of TDMA modulation accuracy, including phase error, magnitude error, and error vector magnitude (EVM)
- Measurements of I/Q origin offset and frequency error
- Measurements of adjacent and alternate channel power
- TDMA power measurement
- $\pi/4$  DQPSK signal generator
- $\pi/4$  DQPSK modulation analyzer
- Continuous/pulsed RF power meter
- Bit-error rate meter
- Baseband data source

#### 83204A TDMA/CDPD Cellular Adapter

For those who already own the 8921A cell site test set, the 83204A Option 003 TDMA/CDPD cellular adapter can be added to upgrade the unit to provide TDMA (IS-136) and CDPD tests on cell site equipment. Once added, all TDMA test features described above are available for manual use as well as under 11807B software control.

#### 83202A Interface Kits

Order the 83202A base station connection kit to receive the necessary cables, connectors, and adapters to connect the 8921A to a specific type of base station. Available options include connection kits for Motorola, Nortel, Ericsson, and Lucent base stations. The 83202A provides everything needed to test base stations with the 8921A. Some connection kits also include an interface/switch box to more fully automate the testing process.

#### 83202A Base Station Connection Kits

- Option 032 Ericsson RBS 882/884 Connection Kit
- Option 040 Motorola Connection Kit
- Option 043 Lucent Connection Kit
- Option 044 Nortel Connection Kit

11807B

## 11807B Software for Automated Base Station Maintenance

Developed from manufacturers' recommended maintenance procedures, the 11807B cell site test software ensures complete test and adjustment of cell sites. Standardizing system maintenance with the 8921A and 11807B software increases system integrity. The fast measurement speed of the 8921A and 11807B software results in less off-line time for each transceiver during maintenance work. Since all cells are uniformly tested using the same test procedure, problems are detected earlier.



Agilent has automated testing solutions for the following manufacturers' equipment:

- Motorola HDII, HDII/NAMPS, LD series, TACS, ETACS, UTACS, and EUTACS
- Ericsson 882 and 882M analog, microcell, 882D DTRM, and 883, and 884
- Lucent Autoplex Series II analog, LMT microcell, and TDMA/CDMA
- Nortel DRU and P-series

## Ordering Information

### AMPS/TACS and CDMA/TDMA/CDPD Cell Site Test

#### 8921A Cell Site Test Set

- Opt 011 CCITT Weighting Filter
- Opt 020 Radio Interface Adapter
- Opt 042 Ericsson PCM Reference
- Opt 500 TDMA Cell Site Test System
- Opt 502 CDPD MBS Cell Site Test System
- Opt 503 TDMA/CDPD MBS Cell Site Test System
- Opt 600 CDMA Cell Site Test System
- Opt 602 CDPD MBS Cell Site Test System
- Opt 603 CDMA/CDPD MBS Cell Site Test System
- Opt W30 Three-Year Warranty

#### 83204A TDMA Cellular Adapter

- Opt 001 TDMA Cellular Adapter, upgradeable to CDPD
- Opt 002 CDPD Cellular Adapter, upgradeable to TDMA
- Opt 003 TDMA/CDPD Cellular Adapter

#### 83205A CDMA Cellular Adapter

- Opt 001 CDMA Cellular Adapter, upgradeable to CDPD
- Opt 002 CDPD Cellular Adapter, upgradeable to CDMA
- Opt 003 CDMA/CDPD Cellular Adapter

### Software for Automated Base Station Maintenance

#### 11807B Cell Site Test Software

- Opt 023 Lucent CDMA Cellular Test
- Opt K23 Lucent CDMA Software Upgrade
- Opt 032 Ericsson RBS 884 Test
- Opt K32 Ericsson RBS 884 Software Upgrade
- Opt 040 Motorola AMPS/NAMPS Test
- Opt K40 Motorola AMPS/NAMPS Software Upgrade
- Opt 042 Ericsson AMPS/TDMA Test
- Opt K42 Ericsson AMPS/TDMA Software Upgrade
- Opt 043 Lucent AMPS/TDMA Test
- Opt K43 Lucent AMPS/TDMA Software Upgrade
- Opt 044 Nortel AMPS/TDMA Test
- Opt K44 Nortel AMPTS/TDMA Software Upgrade
- Opt 050 Motorola TACS/ETACS/UTACS/EUTACS Test
- Opt K50 Motorola TACS/ETACS/UTACS/EUTACS Software Upgrade

### Base Station Connection Kits

#### 83202A Base Station Connection Kit

- Opt 032 Ericsson RBS 882/884 Connection Kit
- Opt 040 Motorola Connection Kit
- Opt 042 Ericsson RBS 882 Connection Kit
- Opt 043 Lucent Connection Kit
- Opt 044 Nortel Connection Kit

- AMPS, CDMA (IS-2000 1XRTT) and TDMA test capability
- Improve technician efficiency and enhance system performance
- Enhanced User Interface
- Rugged, portable design



### 8935 Series Cellular/PCS Base Station Test Sets

The 8935 series is a flexible platform that currently includes two full featured, one-box test sets, for AMPS/CDMA (E6380A) and for AMPS/TDMA (E6381A). The 8935 series is designed to meet the needs of installation teams, service providers, and network equipment manufacturers. Building on the success of our previous generations of base station test equipment, this generation of test gear heavily incorporates feedback from cellular and PCS service providers and network installation teams. For example, the 8935 Series utilizes a larger, bright electro-luminescent display for easily read data. A convenient connector section allows unobtrusive, out-of-the-way hook up. A suitcase form factor provides better portability. The 8935's "rugged design" combines a membrane keypad, a gasketed display, stand up operation, filtered airflow and an enclosure to help protect itself from bumps and shocks.

More importantly, the 8935 incorporates a less intimidating, user-friendly interface with Windows type pull down menus. This new interface, coupled with the 8935's faster measurement speed and automated software for vendor specific base stations results in less off-line time and improved system performance. Errors due to test variability are reduced and measurement data can be output to a printer or to the PCMCIA memory card. Additionally, firmware is user upgradeable with a PCMCIA card to Flash PROM. New features and capabilities can be added without returning the unit to a service center. To round out Agilent's instrument, the 8935 Series includes options for new technician training programs to provide install teams and service providers educational opportunities in AMPS, CDMA, and TDMA technologies and base station test.

### 8935 Series Key Feature Summary

- Power measurements
  - Average power
  - Channel power
- Site Tests (requires E6554A - RF Tools Hardware Accessory Kit)
  - Return loss (SWR) measurements
  - Cable fault location measurements
  - Insertion loss measurements
- Ruggedized design
- Large, electro-luminescent screen (important for outdoor testing)
- Convenient connector placement
- One-button user interface keys
- Pull-down menus
- Optional automation software
- User upgradeable firmware – PCMCIA to Flash PROM
- AM/FM signal generator
- AM/FM modulation analyzer
- Duplex offset generator
- RF power meter
- RF frequency counter/frequency error meter
- Audio frequency counter and power meter
- Spectrum analyzer with tracking generator (400 kHz-1GHz, 1.7-2 GHz)
- Spectrum analyzer mask
- DC current meter
- GPIB/RS-232/parallel remote interfaces
- High-stability time base
- AC/DC voltmeter
- Digital oscilloscope
- Built-in I-BASIC controller
- Decoder for NAMPS

### Rugged Design

The mechanical design of the 8935 Series addresses the physical requirements of today's base station which may be exposed to environmental elements. Ruggedized attributes include:

- Membrane keypad—resists moisture and dirt, easily cleaned, high reliability
- Gasketed display—keeps moisture out
- Stand-up operation—needed for outdoor base stations with no place to set equipment
- Low center of gravity—to minimize tip-overs when unit is standing
- Filtered air-flow—keeps dirt and dust out of instrument for improved reliability and safety

### Portability

The newly enhanced mechanical design provides a "suitcase" form factor that is less bulky and more manageable. No additional add-on boxes are required to implement receiver testing.

### E6380A CDMA Cellular/PCS Base Station Test Set

The E6380A is the CDMA member of the 8935 Series. This one-box solution characterizes Cellular (850MHz) AMPS/CDMA and PCS (1900 MHz) CDMA base stations. Specific CDMA oriented measurements made by the E6380A include:

- CDMA Signal quality measurements
  - Rho ( $\rho$ )
  - Non-intrusive Rho ( $\rho$ )
  - Time offset
  - Frequency error
  - Carrier feedthrough
- Code domain measurements
  - Code domain power (absolute & relative)
  - Code domain timing
  - Code domain phase
- Error vector magnitude, magnitude error, phase error
- PN offset search
- IS-95 CDMA adjacent channel power
- AWGN (built-in calibrated  $E_b/N_0$  levels)
- Support for CDMA reference clocks and triggers

### E6380A IS-2000 Option 200

NEW

- IXRTT TX Test Displays
  - Code domain power (128 code channels, bit reverse order)
  - Code domain noise power (within 128 codes)
  - Code domain displays total power and number of supplemental channels
  - Complex power screen
- IQ constellation diagram
- Estimated Rho ( $\rho$ )



E6381A  
8935 Series

## E6381A TDMA Cellular/PCS Base Station Test Set

The E6381A is the TDMA member of the 8935 Series. This one-box solution characterizes Cellular (850 MHz) AMPS/TDMA and PCS (1900 MHz) TDMA base stations. The E6381A test set provides verification of base station performance using its built in TDMA analyzer. An optional rubidium oscillator is available which provides extremely accurate frequency error measurements. Specific TDMA measurements made by the E6381A include:

- Modulation quality
  - Error Vector Magnitude EVM
  - Phase Error
  - Magnitude Error
  - Carrier feedthrough
- Average power
- Frequency Error
- Channel power
- Adjacent channel power
- First and second alternate channel power

In addition, a pi/4 DQPSK TDMA signal generator is also included in the E6381A. This generator makes the E6381A receiver test capable.

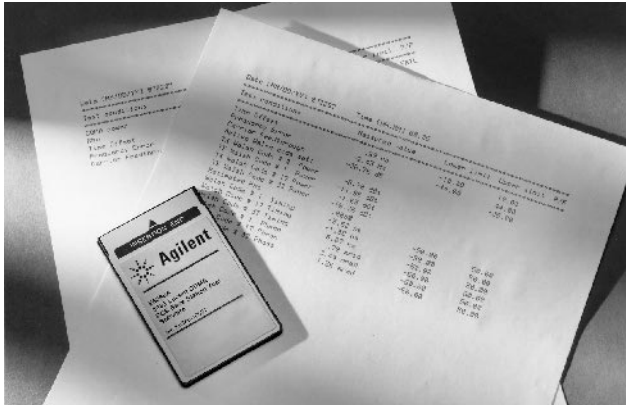

## 8935 Series Software for Automated Base Station Installation and Maintenance

Developed from manufacturer's recommended installation and maintenance procedures, the 8935 Series base station specific test software ensures complete base station testing. Software enhancements for vendor specific base station equipment provides structured, automated testing. A simple menu-driven user interface requires less technical expertise to retrieve consistent reported measurements. Less skilled technicians can make measurements with the same confidence as their highly skilled/experienced counterparts. The software is contained on a PCMCIA card.

## 8935 Series Connection Kits

Order the 8935 Series base station connection kit to receive the necessary cables, connectors, and adapters to connect the 8935 Series to a specific type of base station. Connection kit hardware is housed in a foam filled case.

## Total Support for Your Base Station Test Needs

Agilent offers a variety of options to support base station testing and to keep your solution up-to-date with the latest technology. Agilent also offers start-up assistance and formal training programs. Additional Agilent consulting/training is available as needed.

## Ordering Information

**E6380A** 8935 Series CDMA Cellular/PCS Base Station Test Set

- Opt 1D5** High Stability Frequency Reference
- Opt 200** CDMA IXRTT Test Capability
- Opt OBK** Paper and CD-ROM Manual
- Opt OBC** Manual on CD-ROM Only
- Opt W30** Two years additional warranty
- Opt K08** Two-piece hinged lightweight polyethylene case
- Opt UK6** Commercial calibration certificate with test data
- Opt W30** Two years additional warranty
- Opt W32** Three year return calibration service
- Opt W34** Three year return standards compliant calibration service
- Opt W50** Four years additional warranty
- Opt W52** Five year return calibration service
- Opt W54** Five year return standards compliant calibration service
- RT R58** Firmware upgrade kit
- RT R2K** Retrofit CDMA 2000 kit
- RT R28** Retrofit CDMA 2000 kit

### Software for the E6380A CDMA Base Station Test Set:

- E6385A** Lucent CDMA/AMPS Base Station Test Software
- E6387A** Nortel CDMA PCS Base Station Test Software
- E6550A** Samsung CDMA Base Station Test Solution
- E6551A** LGIC CDMA Base Station Test Solution
- E8303A** Motorola AMPS/NAMPS Base Station Test Software

### Connection kits for the E6380A CDMA Base Station Test Set:

- E6554A** RF Tools Hardware Accessory Kit
- E8300A** Lucent base station connection kit
- E8300A** Option 001 Lucent RF tools hardware accessory kit
- E8302A** Nortel Base Station Connection Kit
- E8302A** Option 001 Nortel RF tools hardware accessory kit
- E83202A** Option 040 Motorola base station connection kit
- E6550A** Option 001 Samsung RF tools hardware accessory kit
- E6551A** Option 001 LGIC RF tools hardware accessory kit

**E6381A** TDMA Cellular/PCS Base Station Test Set

- Opt 003** CDPD Test Module
- Opt AY5** Rubidium Timebase
- Opt OBK** Paper Manuals
- Opt W30** Two Years Additional Warranty

### Software for the E6381A TDMA Base Station Test Set:

- E8304A** Ericsson RBS 882 AMPS/TDMA Base Station Test Software
- E6555A** Ericsson RBS 884 AMPS/TDMA Base Station Test Software
- E6559A** Lucent Cellular AMPS/TDMA/PCS Base Station Test Software
- E6389A** Nortel TRU/P-Series AMPS/TDMA Base Station Test Software

### Connection kits for the E6381A TDMA Base Station Test Set

- E6556A** Ericsson RBS 884 Base Station Connection Kit
- E6558A** Ericsson RBS 882 and 884 Base Station Connection Kit
- E8300A** Lucent Base Station Connection Kit
- E8302A** Nortel Base Station Connection Kit
- E6554A** RF Tools Hardware Accessory Kit



- Over-air BTS testing for IS-95 and J-STD-008 networks
- Monitor BTS performance quickly
- Code domain power and spectrum display
- Collects dynamic code domain statistics
- Measures all CDMA network pilot signals
- CDMA phone-based Lucent BTS MOST test



E7490A

### E7490A CDMA Over-Air Maintenance Tool

Operating a wireless network is an extremely competitive business. In order to stay competitive, it is necessary to continually improve service to attract and retain new customers, and reduce operating costs at the same time. Proactive maintenance can help in both of these areas, but typically takes time that technicians just don't have.

The E7490A CDMA Over-Air Maintenance Tool makes proactive base station testing possible. Technicians can easily execute first-level diagnostics on CDMA base stations using the system's over-the-air measurement functionality. Measurements are fast (less than 5 minutes per sector) and easy (usually 2 or 3 mouse clicks from start to finish with a complete report) and technicians can complete these diagnostics without getting out of their vehicle. The ability to do proactive maintenance with very little impact on the technician's time is particularly important for maintaining difficult to access sites. Pole-top base stations, for example, promise to reduce operating and deployment costs as well as deployment time. However, traditional testing methods are not practical for pole-top installations. With the E7490A, maintaining pole-top installations is now practical.

### System Components

The E7490A software runs on a PC that interfaces with an Agilent digital RF receiver and/or a CDMA mobile phone. Multiple measurements can be made simultaneously and can be displayed real-time and logged to the database. Two system software options are available:

- Code domain power and spectrum mask software license (receiver-based)
- CDMA phone-based BTS test software license

### Receiver-Based Test Software

The receiver-based function of the E7490A system is comprised of two primary elements:

- CDMA code domain power
- Spectrum display with IS-97 mask

Each element has an associated control and display window called a virtual front panel. The software can control up to four digital receivers.

### CDMA Code Domain Power

The code domain power (CDP) software displays measurements for IS-95 and J-STD-008 signals. These measurements provide real-time insight for traffic analysis, capacity management, and base station performance. The code domain virtual front panel is segmented into three measurement types listed below.

- CDP Trace
  - The system measures the relative power of each of the 64 Walsh codes. Data is displayed in bar graph format with unique color for each channel type—pilot, paging, sync, and traffic.
- CDP Statistics
  - The system displays 18 different measurement parameters in large font text format.
    - Frequency channel
    - Channel power
    - Pilot power
    - PN offset number
    - Pilot delay (absolute delay with respect to GPS time)
    - Pilot-paging amplitude delta
    - Pilot-sync amplitude delta
    - Estimated Rho
    - Code domain noise floor
    - Multipath power
    - Pilot dominance
    - Carrier feedthrough
    - Instantaneous number of active traffic channels
    - Average number of active traffic channels
    - Peak number of active traffic channels
    - Average power per active traffic channel
    - Peak power per active traffic channel
    - Percentage of amplifier capacity
- TopN Pilots
  - The system measures all of the pilots in the network and returns the 'N' strongest pilot channels received, where 'N' is a user-definable integer from 1 to 20. The results are displayed in bar graph format.

### Spectrum Display with IS-97 Mask

This measurement provides a spectrum display that includes the spectrum mask as defined in the IS-97 standard. Pass/Fail indicators for the mask are provided at each of the IS-97 frequency offsets. The controls are simple and intended for fast test execution.

### Phone-Based BTS Test Software

This capability automates the Lucent infrastructure CDMA MOST function. When executing a MOST test, the software virtual front panel reports the parameters listed below, in tabular format, for each channel element step.

- Frequency channel
- Cell site
- Antenna face
- Cluster controller
- Channel unit
- Channel element
- FER
- Walsh code

E7490A

**Product Features**

- **Projects**—User-defined test scenarios remember all measurement and display configurations.
- **Automated report generator**—Two mouse clicks produce a complete report of the test.
- **Alarms**—Measurement thresholds and complex Boolean conditions can be defined to alert users of specific signal conditions.
- **Data recording and playback**—Data can be logged to the database and played back via “VCR-like” controls.
- **Data export**—Data can be exported for display and post-processing
- **Scalability**—The system architecture is completely scalable with Agilent’s drive-test solutions. New functionality can be added as measurement requirements change.

**RF Receiver Hardware**

There are eight digital RF receiver options for the E7490A system. The system supports any combination of receivers, up to a total of four.

- Option 300: Cellular band receiver
- Option 310: Cellular band receiver with internal GPS receiver
- Option 320: PCS band receiver
- Option 330: PCS band receiver with internal GPS receiver
- Option 380: Japan Cellular band receiver
- Option 381: Japan Cellular band receiver with internal GPS receiver
- Option 390: Korea PCS band receiver
- Option 391: Korea PCS band receiver with internal GPS receiver

Each receiver option includes:

- RF antenna for the corresponding frequency band
- Cable to connect to other receivers
- Cable to connect to PC
- Kit for mounting receiver in a vehicle
- AC/DC power supply
- Cigarette lighter power cord
- GPS antenna and cables (Options 310, 330, 381, and 391 only)

**Digital RF Receiver Specifications****Frequency****Range**

Options 300, 310: 824–849 MHz [819–854], 869–894 MHz [864–899]  
 Options 320, 330: 1850–1910 MHz [1945–1915], 1930–1990 MHz [1925–1995]  
 Options 380, 381: 832–870 MHz [827–875], 887–925 MHz [882–930]  
 Options 390, 391: 1710–1785 MHz [1705–1790], 1805–1880 MHz [1800–1885]

**Frequency accuracy:**  $\pm 1$  ppm

with GPS time synchronization:  $\pm .05$  ppm characteristic

**IF bandwidth:** 1.25 MHz, 30 kHz, or 200 kHz

**Aging of TCXO:**  $\pm 1$  ppm/year

**Amplitude****Accuracy**

1.25 MHz IF bandwidth:

$\pm 1$  dB;  $\pm 0.5$  dB typical, (20° C – 30° C, –40 to –100 dBm)

$\pm 2$  dB (0° C – 55° C, –40 to –100 dBm)

30 kHz IF bandwidth:

$\pm 1.5$  dB;  $\pm 0.5$  dB typical, (20° C – 30° C, –40 to –100 dBm)

$\pm 2.5$  dB (0° C – 55° C, –40 to –100 dBm)

**Noise figure:** 8 dB typical

**Internally generated spurious:** –120 dBm

**Maximum safe input level:** +10 dBm, 20V DC characteristic

**1 dB compression point:** –15 dBm characteristic

**Adjacent channel desensitization:** –25 dBm typical

**Adjacent channel rejection:** 45 dB typical

**Key Literature**

E7490A Technical Specifications, p/n 5968-8687E

E7490A Configuration Guide, p/n 5968-8696E

E7490A Product Overview, p/n 5968-8697E

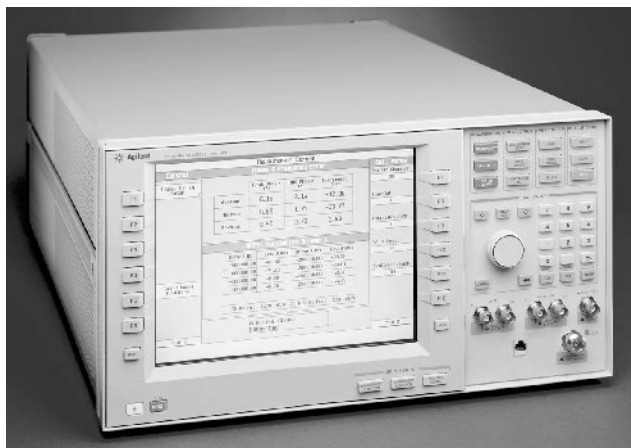

8960 Series 10 Wireless Communications Test Set

### High Production Output Test for Mobile Manufacturing

In high-volume mobile manufacturing, test throughput and test yield are key to meeting production output goals. The Agilent Technologies 8960 Series 10 wireless communications test set offers mobile manufacturers immediate competitive advantages. Developed for high-volume, automated mobile phone manufacturing test, the proven Agilent Technologies 8960 Series 10 test set offers speed, accuracy, repeatability, multi-format capability, ease of programming, and format-flexible architecture. For the mobile manufacturer, this helps lower test costs and improve production output.

#### Test Speed

The 8960 Series 10 can reduce individual test times 30% to 300% compared to previous generation test equipment. Faster measurement means manufacturer's can test a given production volume with fewer test sets, thereby lowering the cost of test and saving floor space. It also gives manufacturers the option to improve mobile phone quality or yield by running additional tests. To deliver this speed, the test set incorporates hardware that has been optimized with fast processing algorithms, a high level command language, and multiple path, multiple processor technology.

#### Accuracy and Repeatability

Speed is only important if a test set is accurate and repeatable. The built in accuracy and repeatability of the 8960 makes manufacturers confident of their phone quality and can be used to improve phone yield and increase phone output. The 8960 earns its accuracy and repeatability by undergoing extensive environmental qualification and production specification verification.

#### Multi-Format

The 8960 can be configured for GSM, GPRS, TIA/EIA-136, AMPS and IS-2000 mobile phones. Manufacturers can test multi-format phones with a single test set, change production from one format to another to meet changing demand, or manufacture different format mobile phones on the same line. For the manufacturer, this means faster response to market changes, less downtime for changeovers, and improved test set utilization.

#### Automated Test

Designed for automated test, the 8960 remote user interface provides high level test commands specific to mobile phone formats. Complex measurement processing, error handling, and statistical functions are built-in and executed with a single command. For the manufacturer, high-level commands simplify test code development and maintenance. New production gets ramped to volume more quickly and test support costs are reduced.

#### Flexible Architecture

Format-flexible architecture is designed to grow with 3G mobile phone technologies. The 8960 is a flexible test set that Agilent Technologies designed to meet the needs of mobile manufacturers now and into the future. As mobile phone technology advances, the 8960 will evolve. New formats will be added and test set hardware changed to provide the needed functionality. Agilent Technologies plans to offer flexible upgrade paths to allow previous models to test new formats where practical.

#### Test Set Configuration

The building blocks of the Agilent Technologies 8960 are mobile phone format specific test applications and generic test set hardware. Agilent Technologies will continue to add new mobile phone formats and improve existing test applications. To get up-to-date configuration information, go to the 8960 web site at [www.agilent.com/find/8960support/literature/configuration\\_guide](http://www.agilent.com/find/8960support/literature/configuration_guide)

#### Key Information

8960 Series 10 web site at: [www.agilent.com/find/8960support](http://www.agilent.com/find/8960support)  
 8960 Series 10 Wireless Communications Test Set Configuration Guide, p/n 5968-7880E  
 8960 Series 10 Multi-Format Test Set Photocard, p/n 5980-0286E

#### Functionality and Specifications

Mobile phone format specific detail for the 8960 Series 10 is listed on subsequent pages. Ordering information follows the technical information at the end of the 8960 pages.

### 8960 Series 10 GSM Mobile Test Set (E5515B with E1960A)

#### Transmitter Measurements

- Frequency error
- Output power
- Phase error (peak and rms)
- Power versus time (burst mask comparison)
- Burst timing
- Output RF spectrum due to switching
- Output RF spectrum due to modulation

#### Receiver Measurements

- Burst-by-burst bit error ratio (fast BER)
- Normal bit error ratio (BER)

#### Audio Functionality

- Speech echo back to mobile station
- Audio generator encoded on downlink TCH
- Audio generator
- Audio level measurement
- Uplink speech level measurement

#### GSM Functionality

- Mobile Station Power Output Level Control: Meets GSM phase one and phase two power control levels
- Traffic Channels: TCH/FS – full rate speech
- Broadcast Channel Configuration: BCCH + CCCH + SDCCH/4
- Signaling Protocol Setup: FACCH
- Audio Speech Echo: One-second fixed delay
- Measurement Coordination: Flexible control of burst type, ARFCN, and timeslot

#### Call Processing Functionality

MS Origination, BS origination, MS release, BS release, Intra-cell channel assignments, Inter-cell handovers

**SAACH reporting of servicing cell:** RX quality, RX level, TX level, Timing advance

**SACCH reporting of first neighbor cell:** Channel number, Base station color code (BCC), RX level, Network color code (NCC)

**Counters reported:** RACH count, Corrupt burst count, Page count, Decode error count, Missing burst count

**Last location information reported:** Location area code (LAC), Mobile country code (MCC), Mobile network code (MNC)

**Mobile-reported information:** International mobile subscriber identity (IMSI), International mobile equipment identity (IMEI), Revision level, Power class, Supported band, Called number

#### Signaling Modes

**Full Signaling Call Setup (active cell mode):** Protocol used to establish, maintain, change channels and power levels, and terminate the link.

**Limited Signaling Call Setup (test mode):** Protocol used only to maintain a link established by the mobile station, over-the-air signaling and capability to demodulate and decode uplink RACH (random access channel) bursts is not available.

8960 Series  
 E1960A  
 E5515B  
 E5515T

# Wireless Mobile & Base Station Test Sets

## 8960 Series 10 Mobile Phone Manufacturing Test Set (cont.)

E1960A  
E1964A  
E5515B



### 8960 Series 10 GSM Technical Specifications (E5515B with E1960A)

#### RF (Downlink) Generator Specifications

RF generator specifications apply to both RF generators in the 8960

#### RF Frequency

**Frequency Range:** 810 to 960 MHz, 1.7 to 1.99 GHz  
**Accuracy and Stability:** Same as timebase reference

#### RF Amplitude

**Output Level Range:** -110 to -13 dBm  
**Absolute Output Level Accuracy:**  $\pm 1.0$  dB

#### GSM Signal Generation

**Peak Phase Error:**  $\leq 4$  degrees  
**rms Phase Error:**  $\leq 1$  degree  
**Frequency Error:**  $\leq \pm 0.02$  ppm plus timebase reference

#### Spectral Purity

**Non-Harmonics:**  
 $\leq -55$  dBc for 100 to  $\leq 1500$  kHz offsets from carrier  
 $\leq -68$  dBc for  $> 1500$  kHz offsets from carrier

#### Transmitter Measurement Specifications

##### Phase and Frequency Error Measurement

**Minimum Input Level:** Signal at test set's RF IN/OUT must have TX output power  $\geq -15$  dBm for warranted performance

##### Frequency Error Measurement Accuracy:

$\leq \pm 12$  Hz plus timebase accuracy for normal bursts  
 $\leq \pm 18$  Hz plus timebase accuracy for RACH bursts

**RMS Phase Error Measurement Accuracy:**  $\leq 1$  degree

**Peak Phase Error Measurement Accuracy:**  $\leq 4$  degrees

##### Transmitter Output Power Measurement

**Minimum Input Level:** signal at test set's RF IN/OUT must have TX output power  $\geq -30$  dBm for warranted performance

##### Measurement Accuracy between 20 and 55° C:

Frequency Range	Amplitude Range	Measurement Accuracy
810 to 960 MHz	+4 to +43 dBm	$\leq \pm 0.32$ dB
1.7 to 1.99 GHz	-20 to +43 dBm	$\leq \pm 0.42$ dB

#### Output RF Spectrum (ORFS) Due to Modulation Measurement

All specifications for the ORFS due to modulation measurement are valid between 20 and 55° C.

**Minimum Input Level:** Signal at test set's RF IN/OUT must have TX output power  $\geq -10$  dBm for warranted performance

**Measurement Accuracy** (referenced to output power in a 30 kHz bandwidth and averaged over 100 measurements):

kHz Offset from Carrier	Power Below Reference (Whichever is Highest)	Measurement Accuracy
$\pm 100$	-10 dB or -46 dBm	$\pm 1.5$ dB
$\pm 200$	-40 dB or -46 dBm	$\pm 1.5$ dB
$\pm 250$	-43 dB or -46 dBm	$\pm 1.5$ dB
$\pm 400$ to $\pm 1800$	-62 dB or -66 dBm	$\pm 1.5$ dB

#### Output RF Spectrum (ORFS) Due to Switching Measurement

All specifications for the ORFS due to switching measurement are valid between 20 and 55° C.

**Minimum Input Level:** Signal at test set's RF IN/OUT must have TX output power  $\geq -10$  dBm

#### Audio Generator Specifications

##### Frequency

**Operating Range:** 100 Hz to 5 kHz  
**Accuracy:** Same as timebase reference

##### Output Level from AUDIO OUTPUT Connector

**Ranges:** 0 to 1 V peak, 1 to 9 V peak (into  $\geq 600 \Omega$ )  
**Accuracy:**  $< (\pm 1.5\% \text{ of setting} \pm \text{measurement resolution})$   
**Distortion:**  $< 0.1\%$  for 0.2 to 9 V peak into  $\geq 600 \Omega$

#### Audio Measurement Specifications

##### Audio Level Measurement

**Measurement Range:** 200 Hz to 8 kHz  
**Measurement Accuracy:**  $\pm (2\% \text{ of reading} \pm \text{measurement resolution})$

##### Uplink Speech Level Measurement

**Types of Signals Measured:** Speech present on uplink TCH pulsed with 50% duty cycle at a 10 Hz rate  
**Measurement Range:** 200 Hz to 8.6 kHz  
**Measurement Accuracy:** Observed inaccuracies are due to mobile phone encoder errors since the algorithm in the 8960 contributes no bit errors

### 8960 Series 10 GPRS Mobile Test Set (E5515B with E1964A)

#### Multi-slot Configurations

1x1, 2x1, 3x1, 2x2

#### Coding Schemes

CS-1 and CS-4

#### Frequency Bands

GSM, EGSM, DCS1800, PCS1900

#### Signaling Modes

Active Cell, Test Mode (2), CW

#### ETSI Test Mode with Loopback

##### Transmitter Measurement

###### Single slot measurements:

ORFS for both modulation and switching

###### Multi-slot measurements:

Transmitter Power  
Phase and Frequency Error  
Power/Time template with ETSI multi-slot mask

##### Receiver Measurements

Bit Error Ratio (BER)  
Block Error Ratio (BLER)



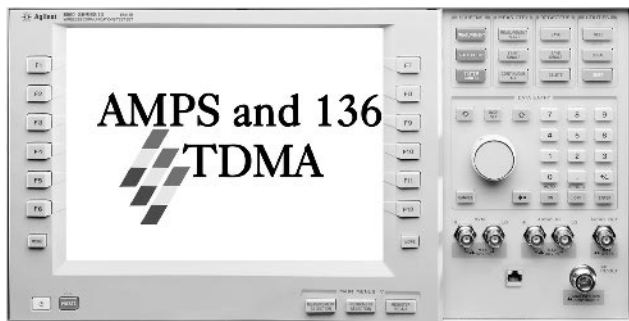

**AMPS/136 (TDMA) Mobile Test Set (E5515B with E1961A)**

NEW

### Measurements

#### Transmitter Measurements

- RF Frequency Error and Frequency
- Output power
- FM Deviation Distortion and Frequency
- Modulation Accuracy
- Error Vector Magnitude (EVM & EVM10)
- Magnitude and Phase Error
- Frequency Error
- Origin Offset
- Adjacent Channel Power
- IQ tuning

#### Receiver Measurement

- Loopback Bit Error Rate (LBER)

#### Audio Functionality

- Audio generator
- Audio analyzer (level, SINAD, distortion, frequency)
- Expander, de-emphasis and filtering

#### Call Processing Functionality

- Origination from BS or MS
- Release from BS or MS
- Digital and analog modes (ACC, AVC, DCCH, DTC)
- Selectable call setup parameters
- Handoffs between all bands and all modes
- MAHO reporting: RSSI, BER ranges, and neighboring cell power.

### Signaling Modes

**Full Signaling Call Setup (active cell mode):** Protocol used to establish, maintain, change channels and power levels, and terminate the link.

**Limited Signaling Call Setup (test mode):** Protocol used only to maintain a link established by the mobile station, over-the-air signaling and capability to demodulate and decode uplink RACH (random access channel) bursts is not available

**CW (cw mode):** Provides unbursted, unmodulated RF signals over the operating frequency and amplitude ranges. Used to test mobile phone functions by setting desired RF frequency and amplitude.

### RF Generator Specifications

#### RF Frequency

**Frequency Range:** 800 to 960 MHz, 1.7 to 2.0 GHz  
**Accuracy and Stability:** Same as timebase reference

#### RF Amplitude

**Output Level Range:** -116 to -15 dBm  
**Absolute Output Level Accuracy:**  $\pm 1.0$  dB  
**Typical VSWR at RF IN/OUT:**  $< 1.2:1$  for 800 to 960 MHz;  
 $< 1.25:1$  for 1.7 to 2.0 GHz

#### FM and SAT Signal Generation

**FM Rate Range:** 100 Hz to 20 kHz  
**FM Deviation Range:** 0 to 20 kHz for combined SAT, internal and external deviation  
**Residual FM:**  $< 7$  Hz rms in a CCITT bandwidth

**TDMA Signal Generation**  
**Frequency Error:**  $< \pm (4 \text{ Hz} + \text{timebase error})$   
**EVM:**  $< 3.0\%$  rms  
**Origin Offset:**  $< -35$  dBc

### Audio Generator Specifications

#### Frequency

**Operating Range:** 100 Hz to 20 kHz  
**Accuracy:** Same as timebase reference

#### Output Level from AUDIO OUTPUT Connector

**Ranges:** 0 to 1 V peak, 1 to 9 V peak (into  $\geq 600 \Omega$ )  
**Accuracy:**  $< \pm (1.5\%$  of setting + resolution)  
**Distortion:**  $< 0.1\%$  for 0.2 to 9 V peak (into  $\geq 600 \Omega$ )

### Analog & Digital RF Analyzer Specifications

#### Analog TX Power Measurement

**Minimum Input Level:** Signal at test set's RF IN/OUT must have analog TX power  $> -30$  dBm for warranted performance

**Measurement Accuracy (for 20° C to 55° C):**  $< \pm 0.32$  dB for 800 to 960 MHz,  $< \pm 0.42$  dB for 1.7 to 2.0 GHz

**Deviation and Frequency Measurement Rate Range:** 100 Hz to 15 kHz

**Distortion Measurement Rate Range:** 100 Hz to 10 kHz

**Residual FM:**  $< 7$  Hz rms in a C-message bandwidth,  $< 1.5$  Hz rms in a 100 Hz bandwidth using the tunable band pass filter

#### Frequency Stability Measurement

**Measurement Accuracy (for signals with no modulation):**

$< \pm (1 \text{ Hz} + \text{timebase accuracy})$  for 800 to 960 MHz,

$< \pm (3.5 \text{ Hz} + \text{timebase accuracy})$  for 1.7 to 2.0 GHz

### Digital Transmitter Specifications

#### Modulation Accuracy Measurement

**EVM Accuracy:**  $< \pm (2\%$  of reading + residual EVM)

**Origin Offset Accuracy:**  $< \pm 0.5$  dB for origin offset  $\geq -40$  dBc

**Frequency Error Accuracy:**  $< \pm (10 \text{ Hz} + \text{timebase accuracy})$

#### Digital TX Power Measurement

**Minimum Input Level:** Signal at test set's RF IN/OUT must have digital TX power  $\geq -30$  dBm for warranted performance

**Measurement Accuracy (for 20° C to 55° C):**  $< \pm 0.38$  dB for 800 to 960 MHz,  $< \pm 0.48$  dB for 1.7 to 2.0 GHz

### Adjacent and Channel Power Measurement

**Measurement Accuracy for  $\pm 30$ ,  $\pm 60$  and  $\pm 90$  kHz Offsets:**  $< \pm 1.2$  dB

### Audio Analyzer Specifications

Filter choices of none, C-message, 50 Hz to 15 kHz band pass, 300 Hz to 15 kHz band pass or 100 Hz bandwidth tunable band pass, tunable over 300 Hz to 15 kHz

#### Audio Level Measurement

**AUDIO IN Level Range:** 7.1 mV to 20 V peak (5 mV to 14.1 V rms)

**Measurement Accuracy:**  $< \pm (2\%$  of reading + resolution) for 100 Hz to  $< 8$  kHz,  $< \pm (3\%$  of reading + resolution) for  $> 8$  kHz to 20 kHz

**Measurement THD Plus Noise:**  $< 200$  mV rms

**Measurement Resolution:** 0.3% of expected level setting or 0.2 mV, whichever is greater

### Audio Frequency Measurement

**AUDIO IN Level Range:** 7.1 mV to 20 V peak (5 mV to 14.1 V rms)

**Measurement Accuracy:**  $< 0.1$  Hz averaged over 10 measurements,  $< 1.0$  Hz for a single measurement

**Measurement THD Plus Noise:**  $< 200 \mu\text{V}$

### SINAD and Distortion Measurements

**Measurement Frequency Range:** 100 Hz to 10 kHz

**AUDIO IN Level Range:** 42.4mV to 20V peak (30mV to 14.1Vrms)

**SINAD Measurement Accuracy:**  $< \pm 1.0$  dB for SINAD  $< 44$  dB

**Distortion Measurement Accuracy:**  $< \pm 12\%$  ( $\pm 1.0$  dB) for distortion  $> 0.67\%$

**Residual THD Plus Noise:**  $< -60$  dB or 200 mV rms, whichever is greater

Note: E1961A tests mobiles per TIA/EIA 137 specifications

E1962A  
E5515T

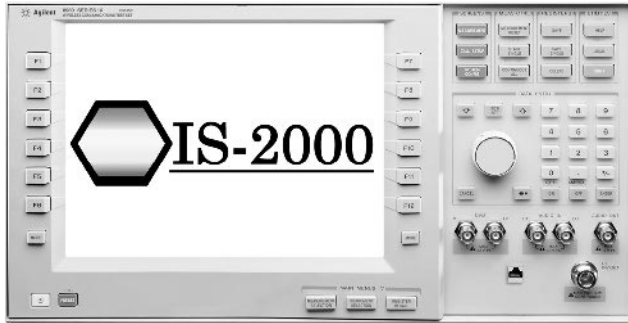

## IS-2000 Mobile Test Mode Test Set (E5515T with E1962A)

NEW

The E1962A Test Application, when combined with the 8960 Series 10 Wireless Communications Test Set Model E5515T, provides IS-2000 mobile phone RF parametric test capability without call processing using special test modes that must be built into the IS-2000 mobile phone.

The E1962A has been designed specifically for R&D engineers and early manufacturers of IS-2000 mobile phones. It provides IS-2000 forward link emulation which allows the mobile phone to synchronize and camp onto the forward link. Once camped onto the forward link, the mobile must be directed to decode the forward traffic channel using a built-in test mode. When the mobile phone begins to decode the forward traffic channel and transmits back to the test set, waveform quality, average power, and channel power transmitter measurements can be performed. By using a mobile phone internal Frame Error Rate counter, receiver measurements such as sensitivity and demodulation with AWGN can also be performed.

Using test modes built into the IS-2000 mobile phone, the following tests can be performed:

### TX Tests

- Maximum Power
- Minimum Power
- Waveform Quality (including frequency error)
- Open Loop Power Accuracy
- Open Loop Power Calibration Procedure

### RX Tests

- Sensitivity
- Dynamic Range
- Demodulation of the F-FCH with AWGN

The E1962A with the E5515T also provide flexible IS-2000 forward link emulation including control of the Pilot, Sync, Paging, F-FCH, S-SCH, AWGN levels, and data rates for a variety of R&D testing applications.

## Key Functionality

### Transmitter Measurements

- Average Power**
- Channel Power**
- Waveform Quality**
  - Rho (IS-95)
  - EVM (IS-2000)
  - Frequency Accuracy

### Receiver Measurements

None, Frame Error Measurement must be performed by mobile phone

### Frequency Range:

- 800 MHz to 925 MHz
- 1700 MHz to 2170 MHz

### Overhead Channels:

- F-Pilot** with user settable PN Offset.
- F-Sync** with real-time long code and system-time update, and updates for user-entered parameters such as SID, NID, P\_REV, and PN OFFSET.
- F-Paging** with real-time overhead messages.

**Protocol Stack:** limited to IS-2000 Revision 0 Sync channel message and overhead messages on the Paging channel, no call processing.

**Base Station Parameters:** NID, SID, Country Code (BCC), Network Code (BNC), Reverse Link Traffic Pilot Gain.

**Chip Rate:** 1.2288 Mcps.

### Forward Radio Configuration Support:

- Radio Config 1
- Radio Config 2
- Radio Config 3.
- Radio Config 4.
- Radio Config 5.

**Channel Coding:** Convolutional and Turbo

**Traffic Data Source:** PRBS (CCITT 2 15-1 pattern).

**Forward-SCH Data Rates** (one F-SCH):

- RC3: 9.6, 19.2, 38.4, 76.8 kbps.
- RC4: 9.6, 19.2, 38.4, 76.8, 153.6 kbps.
- RC5: 14.4, 28.8, 57.6, or 115.2 kbps.

### Reverse Link Closed Loop Power Control Modes:

- 'ALTERNATING' - Alternating 0 and 1 power bits
- 'ALL UP'
- 'ALL DOWN'

## Signal Generator

### CDMA Channels:

F-Pilot, F-Sync, F-Paging, F-FCH, F-SCH, F-OCNS

### CDMA Modulation:

Parallel BPSK for Pilot, Sync, and Paging channels and Complex QPSK for the F-FCH per IS-2000.

**AWGN:** Minimum bandwidth of 1.8 MHz

## CDMA Analyzer

### Average Power Measurement

Measurement Bandwidth: at least 1.8 MHz

### Tuned Channel Power Measurement

Measurement Bandwidth: Measures the total power in a 1.23 MHz bandwidth centered on the active reverse channel center frequency.

### Modulation Quality Measurement

Measurement Chip Rate: 1.2288 Mcps.

### Modulation Measurement Format

OQPSK (RC1, RC2) or HPSK (RC3, RC4, and RC5).

### Modulation Quality Measurement

rho/EVM.

### Frame Error Rate Measurement

No internal measurement. Must be implemented in mobile phone.

### General Specifications

**Power Requirements:** 100 to 240 VAC, 50 to 60Hz  
**Power Consumption:** 550 VA maximum  
**Operating Temperature:** 0° C to 55° C  
**Size:** 222 mm H x 426 mm W x 625 mm D (8.75 in x 16.75 in x 24.63 in)  
**Weight:** 30 kg (66 lb)

### Ordering Information

#### Test Set Hardware

**E5515B** 8960 series 10 wireless communications mainframe  
 (Requires at least one test application, see below)

**E5515T** 8960 series 10 IS-2000 test mode mainframe  
 (Requires E1962A Test Application, see below)

**Option 002** Second RF Source (Required for E1960A GSM and E1964A GPRS mobile test applications)

**Option AX3** Handles

**Option AX4** Rack flange kit without handles

**Option AX5** Rack flange kit with handles

**Option B8A** Performance verification at installation.

**Option UK6** Commercial calibration certificate with test data

**Option W30** 3-year customer return repair service

**Option W50** 5-year customer return repair service

#### Test Applications

**E1960A** 8960 series 10 GSM mobile test application.  
 (Requires E5515B Option 002, second RF source)

**E1961A** 8960 series 10 AMPS/136 mobile test application

**E1962A** 8960 series 10 IS-2000 test mode application  
 (Requires E5515T mainframe)

**E1964A** 8960 series 10 GPRS mobile test application  
 (Requires E5515B Option 002, second RF source and E1960A, GSM test application)

**Option 0B0** Delete documentation set (No paper guides, cards, user documentation CD-ROM, or test application CD-ROM)

**Option 0BK** Printed manuals (reference, calibration, and assembly level repair)

E5515B  
 E5515T  
 E1960A  
 E1961A  
 E1962A  
 E1964A

E8285A  
E8290A  
83217A



E8285A

### E8285A CDMA Mobile Station Test Set

Acting as a calibrated, high performance CDMA base station, the E8285A CDMA Mobile Station Test Set provides the key set of measurements to manufacture high quality Dual Mode CDMA cellular and PCS mobile telephones in a single box. In addition to its CDMA functionality, the E8285A includes full AMPS, NAMPS, TACS, NTACS and JTACS analog phone test capability. With the E8285A, you save cost by making both analog cellular and CDMA digital cellular/PCS measurements with one instrument.

### CDMA Base Station Simulator

The E8285A includes a full QPSK signal generator that follows the IS-95 and/or TIA/EIA-95B CDMA air interface specifications for base stations. The CDMA signal generator supports an AWGN (Additive White Gaussian Noise) source as well as two CDMA sectors. Sector A supports the following CDMA channels: Pilot, Sync, Paging, Traffic, and OCNS. Sector B offers Pilot, Traffic and OCNS channels. Absolute power is individually settable for the AWGN source, Sector A and Sector B in terms of total power in a 1.23 MHz bandwidth. Using industry standard ASICs, the E8285A supports the protocol required to emulate a CDMA base station for mobile station test.

### Functional CDMA Mobile Test

The E8285A supports mobile or base station terminated call connect and disconnect. To check voice quality the E8285A offers a voice echo mode. When active the voice echo mode delays and then retransmits to the mobile phone any audio spoken into it. An operator can quickly verify voice quality by speaking into the phone and then listening to the echoed audio in the mobile handset. The E8285A can also send pre-coded audio tones of 400 Hz, 1 kHz and an audio sweep to the phone for further audio testing.

### CDMA Transmitter Tests

Transmitter tests include fast DSP based average power measurements from +34 dBm to -10 dBm and accurate channel power and access probe power measurements from +30 dBm to -50 dBm. The tuned channel power measurement reports the power in a 1.23 MHz bandwidth. These two power measurement modes allow accurate verification of maximum power, minimum power, open loop power control, and closed loop power control.

The E8285A measures transmitted waveform quality by the TIA/EIA-98-A recommended correlated power method "p" (rho). In addition the "p" measurement reports the frequency error, phase error, amplitude error, time offset, and carrier feedthrough of the mobile phone CDMA transmitted signal.

The E8285A features the Gated Power and Open Loop Time Response graphical measurements. The Gated Power measurement, for which the E8285A displays the time response of an ensemble of power control groups, is implemented on the "CDMA Gated Power Test" screen. The Open Loop Time Response, for which the E8285A displays the time response of the mobile station's output power in response to a step change in the instrument's output power, is implemented on

the "Open Loop Time Response" screen. Graphical results, comparison to a mask, and pass/fail results are given for both measurements.

The Swept Power measurement also provides a method to capture a graphical trace of mobile phone power versus time for various applications. This new feature has a flexible amplitude trigger and a variable dynamic range.

### CDMA Receiver Tests

The key performance parameter for CDMA mobile station receivers is Frame Error Rate with and without the presence of AWGN. The built-in high accuracy AWGN generator in the E8285A guarantees the FER tests provide the true picture of a CDMA mobile ability to correctly demodulate a signal in the presence of high interfering noise. The E8285A fully supports service Options 002 and 009 (RF loopback mode) to test receiver FER performance. The E8285A optimizes FER measurement time by employing confidence limit technology. With confidence limits, FER measurements are made in the fastest possible time.

### Hand-off Verification

To speed testing, the E8285A supports hard hand-offs between RF channels. CDMA to analog hand-offs from both cellular and PCS bands are also supported. Interband handoffs between TSB-74 (cellular band CDMA protocol) and J-STD-008 (PCS band CDMA protocol) are also supported. With two configurable CDMA sectors, the E8285A can verify the ability of a CDMA mobile to support softer hand-offs. Two E8285A test sets can be synchronized for more complete idle and soft hand-off testing.

### Short Message Service Testing

The E8285A supports mobile terminated SMS on both paging and traffic channels. Messages can be sent in both ASCII and HEX formats to support international character sets.

### CDMA and AMPS Authentication Testing

The E8285A includes authentication tests which support both CDMA (US and Korean) and AMPS. The E8285A displays expected mobile phone values and actual values returned. SSD update, A-key entry, RANDC and other authentication procedures are supported.

### Additional Protocol Messages

Recently, the following additional protocol message support was added to the test set, allowing customers to more fully perform certain TIA/EIA-98-B/C, ANSI J-STD-018 and CDG Stage 2 tests:

- The ability to send a PMRO (Pilot Measurement Request Order) when desired.
- The ability to send an Audit Order at the beginning of each valid paging slot.
- The ability to send an EHDM (Extended Handoff Direction Message) when desired.
- The ability to send a custom neighbor list entry with frequency included.
- The ability to perform power-down registration.

### 83217A Dual-mode Mobile Station Test Software

Besides its many measurement functions, the E8285A includes a programmable IBASIC controller. The 83217A Option 004 automates CDMA dual-mode mobile measurements using the E8285A. Automated testing improves consistency and reduces operator error resulting in lower operation costs and improved product quality.

### E8290A Point of Service Test Software

The new E8290A PoST (Point of Service Test) Software makes the E8285A an easy to use automated CDMA test solution. The E8290A quickly provides accurate phone performance and quality data at the point of sale. This PC-based solution is very easy to use, reduces churn, reduces NTF (No Trouble Found), and improves customer care. Test results can also be stored in databases for further analysis.



## E8285A Analog Mode Specifications

## Signal Generator

## Range

800 MHz to 1000 MHz,  
1700 MHz to 2000 MHz.

## RF IN/OUT Connector

**Level Range:** -120 dBm to -18 dBm into 50 ohms

## Level Accuracy:

±1.0 dB (800 MHz to 1000 MHz), typically ±0.7 dB.  
±1.25 dB (1.7 to 2.0 GHz), typically ±1.0 dB.

**Reverse Power:** 2.5 watts

## DUPLEX OUT Connector

**Level Range:** -120 dBm to -8 dBm into 50 ohms

**Level Accuracy:** ±1.0 dB

## FM Deviation (rates &gt;25 Hz):

100 kHz; 800 to 1000 MHz,  
100 kHz; 1700 MHz to 2000 MHz.

## Audio Source (both internal sources)

**Range:** dc to 25 kHz

**Accuracy:** 0.025% of setting

**Range:** 0.1 mV to 4 Vrms

## RF Analyzer

RF Frequency Measurement

Measurement Range:

800 to 1000 MHz,  
1700 MHz to 2000 MHz.

## RF Power Measurement

**Accuracy:** ±7.5% (-10 dBm to +30 dBm)

**Measurement Range:** -10 dBm to +34 dBm (0.1 mW to 2.5 W)

## FM Measurement

## Frequency Range

800 to 1000 MHz,  
1700 MHz to 2000 MHz.

**Deviation Range:** 20 Hz to 75 kHz

## Spectrum Analyzer (Option 102)

## Frequency Range

800 to 1000 MHz,  
1700 MHz to 2000 MHz

**Resolution Bandwidth** (coupled): 300 Hz to 300 kHz

**Display Range:** 80 dB

## Audio Analyzer

## Frequency Measurement

**Measurement Range:** 20 Hz to 400 kHz

**Accuracy:** ±0.02% plus resolution plus reference oscillator accuracy

## SINAD Measurement

**Fundamental Frequency Range:** 300 Hz to 10 kHz ±5%

**Input Level Range:** 30 mV to 30 Vrms

**Accuracy:** ±1 dB for frequencies from 300 to 1500 Hz, measured with the 15 kHz LPF (0 to 46 dB SINAD).

## Oscilloscope

**Frequency Range** (-3 dB BW): 2 Hz to 50 kHz

**Scale/Division:** 10 mV to 10 V

## CDMA Signal Generator

## CDMA Channels:

## Additive White Gaussian Noise

**Sector A with Selectable PN Offset:**

Pilot Channel at Walsh Code 0

Sync Channel at Walsh Code 32

Paging Channel at Walsh Code 1

Traffic Channel with selectable Walsh Code

OCNS Channel with selectable Walsh Code

**Sector B with selectable PN offset:**

Pilot Channel at Walsh Code 0

Traffic Channel with Selectable Walsh Code

OCNS Channel with Selectable Walsh Code

## Frequency

## Frequency Range

800 MHz to 1000 MHz,  
1700 MHz to 2000 MHz

## Amplitude

## Composite Signal Output Level Range:

## RF IN/OUT

-120 dBm/1.23 MHz to -20 dBm/  
1.23 MHz, useable to -15 dBm.

## DUPLEX OUT

-120 dBm/1.23 MHz to -10 dBm/  
1.23 MHz, useable to -10 dBm.

## Composite Signal Output Level Accuracy

## AWGN Off

±1.25 dB 800 MHz to 1000 MHz,  
±1.35 dB 1700 MHz to 2000 MHz

**Relative CDMA Channel Level Accuracy:** <0.2 dB

## CDMA Analyzer

## CDMA Average Power Measurement

## Input Frequency Range

800 to 1000 MHz,  
1700 MHz to 2000 MHz.

**Measurement Range:** -10 dBm to +34 dBm

**Accuracy:** -10 dBm to +30 dBm

±7.5% ±1 µW (100 MHz to 1000 MHz)

±8% ±1 µW (1.7 GHz to 2.0 GHz) Typically ±5%

## CDMA Tuned Channel and Access Probe Power Measurements

## Measurement Range

**RF IN/OUT:** -50 dBm to +30 dBm

**ANT IN:** -70 dBm to +15 dBm

## CDMA Modulation Measurement

**Measurement Input Level Range:** -20 dBm to +34 dBm

**Measurement Accuracy:** ±0.003

**Frequency Error Measurement Accuracy:** ±30 Hz ± timebase accuracy

## CDMA Frame Error Rate Measurement

**FER Measurement Method:** Data loopback per Service Option 002 or Service Option 009 supporting Confidence limits as outlined in TIA/EIA-98-B

**FER Reported Parameters:** Measured FER, Number of Errors, Number of Frames tested, and one of the following: Passed Confidence limit, Failed Confidence limit, or Max. Frames (test indeterminate)

## General Specifications

**Dimensions:** 22.2 cm H x 42.5 cm W x 59.0 cm D

(8.74 in x 16.73 in x 23.23 in)

**Weight:** 22 kg (48 lbs)

**Operating Temperature:** 0° C to +55° C

**Power:** 100 V to 240 V, 50/60 Hz, nominally 250 VA.

**Calibration Interval:** Two years

## Ordering Information

**E8285A** CDMA PCS mobile station test set

**Opt 002** Add E8290A PoST automated PC software

**Opt 011** Add CCITT filter for TACS/ETACS

**Opt 102** Add spectrum analyzer with

tracking generator

**Opt 0B0** Delete manual set.

**Opt 0B1** Add one additional manual set.

**Opt 0BW** Printed service documentation, assembly-level.

**Opt AX4** Rack flange kit.

**Opt UK6** Commercial calibration certificate with test data.

**E8290A** Point of service test software

**83217A** CDMA Dual Mode MS test software

Must order one and only one option per unit 83217A

**Opt 004** PCS CDMA/NAMPS/AMPS

E8285A  
E8290A  
83217A

8924E

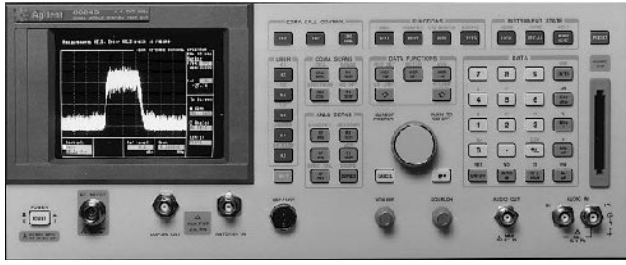

8924E

### 8924E CDMA Mobile Station Service Test Set



The 8924E is optimized for the following applications:

- Incoming inspection for service providers
- Failure and repair verification for service organizations

The 8924E CDMA Mobile Station Test Set provides the key set of measurements to verify the performance of dual-mode CDMA mobile phones operating from 500 to 1000 MHz. With the 83236B PCS Interface, the 8924E additionally offers CDMA mobile testing from 1700 to 2000 MHz. Acting as a calibrated, high performance CDMA base station, the 8924E verifies not only the parametric characteristics of CDMA phones, but also the functional aspects of phone performance.

The 8924E's full AMPS, NAMPS, EAMPS, TACS, NTACS, ETACS and JTACS test capability saves you space, cost, and training expenses by allowing you to make both analog and CDMA digital measurements with the same instrument.

For complete, call processing verification, the 8924E supports both mobile and base station initiated call connect and disconnect. Once a phone call is established, verifying the overall functionality of a CDMA mobile is simple using the 8924E's voice echo mode. For testing a variety of protocol formats, the 8924E offers seven user selectable protocol stacks: IS-95, IS-95A, TIA/EIA-95B, TSB-74, J-STD-008, ARIB T53, and KOREAN PCS. The 8924E also supports a number of service options, including 9600 BPS and 14,400 BPS traffic channel configurations.

### High Accuracy CDMA Source for CDMA Receiver Test

Active cell site emulation in the 8924E sector source supports the following CDMA channels: Pilot, Sync, Paging, Traffic, and Orthogonal Channel Noise Source (OCNS). An Additive White Gaussian Noise (AWGN) Source is also included to provide the interference generated by adjacent cells in a working CDMA network. The 8924E measures receiver Frame-Error-Rate (FER) at all four data rates used in the CDMA system: full, half, quarter, and one-eighth. Confidence limit technology is used to reduce receiver test time to an absolute minimum.

### CDMA Transmitter Measurements

The 8924E provides an average power measurement based on DSP technology. A DSP based channel power measurement enables the 8924E to achieve accurate low level CDMA power measurements. Access probe power measurements are also available. The 8924E measures transmitted waveform quality by using the IS-98A/J-STD-018 recommended correlated power method, also known as the rho measurement. In addition, the rho measurement reports the frequency error, modulation phase and amplitude error, and the carrier feedthrough.

### Handoff Verification

To speed testing, the 8924E supports hard hand-offs between RF channels. CDMA to analog hand-offs from both cellular and PCS bands are also supported.

### Authentication and Short Message Service Support

The 8924E provides the necessary features for testing a CDMA mobile station's ability to perform call processing functions with Authentication for Korea and the United States. Also, the 8924E supports mobile terminated SMS.

### Automated Software

The new E8290A PoST (Point of Service Test) Software makes the 8924E an automated CDMA test solution. The E8290A quickly provides accurate phone performance and quality data at the point of sale. This PC-based solution is very easy to use, reduces churn, reduces NTF (No Trouble Found), and improves customer care.

The 83217A CDMA Dual Mode Mobile Station Test Software can also be used to automate CDMA and analog mobile phone measurements. The 83217A solution does not require a PC. Rather, automatic tests can be completely set up using the front panel of the 8924E. Options are available to meet your test needs for CDMA, AMPS, NAMPS, JTACS, NTACS, U.S PCS and Korean PCS phones.

### Ordering Information

#### 8924E CDMA Mobile Station Service Test Set

- Opt 001 E8290A PoST Software
- Opt 011 ETACS CCITT Filter
- Opt 0BW Service Documentation
- Opt 0B1 Add Manual Set
- Opt AX4 Rack Flange Kit
- Opt W30 3 Years of Customer Return Repair Service
- Opt W50 3 Years of Customer Return Repair Service
- Opt 102 Add Spectrum Analyzer with tracking generator (standard on 8924E)
- Opt 601 Adds PCS Interface

#### 83217A CDMA Dual Mode MS Test Software

Must order one and only one option per unit 83217A

- Opt 001 AMPS/NAMPS/CDMA
- Opt 003 JTACS/CDMA
- Opt 004 PCS CDMA/NAMPS/AMPS

#### E8290A Point of Service Test Software

#### 83236B PCS Interface

**Analog Mode Specification Summary****Signal Generator****RF Frequency Range**

Standard: 30 MHz to 1000 MHz  
With Option 601: 800 MHz to 960 MHz, 1710 MHz to 1990 MHz

**Output****RF In/Out Connector****Level Range**

Standard: -127 to -10.5 dBm into 50 ohms  
With Option 601: -130 to -20 dBm into 50 ohms

**Level Accuracy**

Standard:  $\pm 1.2$  dB (Level  $\geq -127$  dBm)  
With Option 601:  $\pm 1.8$  dB @ 25° C  $\pm 10^\circ$  C

**Reverse Power**

Standard: 3 watts continuous  
With Option 601: 10 watts continuous

**Duplex Out/RF Out Only Connector****Level Range**

Standard: -127 to +3.5 dBm into 50 ohms  
With Option 601: -130 to -10 dBm into 50 ohms

**Level Accuracy**

Standard:  $\pm 1.0$  dB (Level  $\geq -127$  dBm)  
With Option 601:  $\pm 1.8$  dB @ 25° C  $\pm 10^\circ$  C

Reverse Power: 200 mW maximum

**Maximum FM Deviation (rates > 25 Hz)**

Standard: 100 kHz; 501 MHz to 1000 MHz  
With Option 601: 100 kHz; 800 to 960 MHz, 1710 to 1990 MHz

**RF Analyzer****Frequency Measurement Range**

Standard: 30 MHz to 1000 MHz  
With Option 601: 800 MHz to 960 MHz, 1710 MHz to 1990 MHz

**RF Power Measurement (RF in/out connector only)****Measurement Range**

Standard: -10 dBm to +35 dBm (0.1 mW to 3 W)  
With Option 601: -13 dBm to +40 dBm (50  $\mu$ W to 10 W)

**Accuracy**

Standard:  $\pm 5\%$  of reading  $1 \mu$ W from 15° C to 35° C  
With Option 601:  $\pm 5\%$  of reading  $\pm 2.5 \mu$ W from 13° C to 33° C

**Spectrum Analyzer****Frequency Range:**

Standard: 30 MHz to 1000 MHz  
With Option 601: 800 MHz to 960 MHz, 1710 MHz to 1990 MHz

**Resolution Bandwidth (coupled to span):** 300 Hz to 300 kHz**Display Range:** 80 dB**AF Analyzer****Frequency Measurement**

Measurement Range: 20 Hz to 400 kHz  
Accuracy:  $\pm 0.02\%$  + resolution + reference oscillator accuracy

**SINAD Measurement**

Fundamental Frequency Range: 300 Hz to 10 kHz  $\pm 5\%$   
Accuracy:  $\pm 1$  dB for Fc=300 to 1500 Hz, using the 15 kHz LPF  
Residual THD+Noise: -60 dB or 150  $\mu$ V, whichever is greater

**Oscilloscope****Frequency Range** (-3 dB BW): 2 Hz to 50 kHz**Scale/Division:** 10 mV to 10 V**Time/Division:** 10  $\mu$ s to 100 ms**Remote Programming**

**GPIOB:** Agilent's implementation of IEEE Standard 488.2

**RS-232:** 3-wire RJ-11 connector used for serial data in and out

**Centronics Port:** Industry standard parallel printer port

**Ovenized Reference**

**Aging Rate:** <0.005 ppm pk-pk/day,  $\leq \pm 0.1$  ppm per year

**CDMA Mode Specification Summary****CDMA Call Processing Functionality**

**Protocol Stack:** IS-95, IS-95A, TIA/EIA-95B TSB-74, J-STD-008, and ARIB-T53

**Service Option Modes:** SO 001, SO 002 (9600 bps loopback), SO 003, SO 009 (14400 bps loopback), SO 32768, SO 006, and SO 014

**Traffic Channel Data Rates:** 9.6 kbps or 14.4 kbps

**Call Control:** BS call originate, BS call disconnect, MS call originate, MS call disconnect

**Hand-off Support:** CDMA to CDMA Hard (RF Frequency), CDMA Softer (8924C only), CDMA to Analog (intraband), CDMA PCS to CDMA cellular, and CDMA PCS to Analog Cellular  
CDMA Soft (requires 2 units) (8924C only)

**CDMA Signal Generator****CDMA Channels****Additive White Gaussian Noise**

**Sector A** – includes the following channels: Pilot Channel, Sync Channel, Paging Channel, Traffic Channel, and OCNS Channel

**Sector B** – includes the following channels: Pilot Channel, Traffic Channel, and OCNS Channel (8924C only)

**Frequency Range**

Standard: 501 MHz to 1000 MHz, usable from 30 to 248.9 MHz  
With Option 601: 800 MHz to 960 MHz, 1710 MHz to 1990 MHz

**Composite Signal Output Level Range****Standard:**

RF In/Out: -109 dBm/1.23 MHz to -21.5 dBm/1.23 MHz  
Duplex Out: -109 dBm/1.23 MHz to -7.5 dBm/1.23 MHz

**With Option 601:**

RF In/Out: -109 dBm/1.23 MHz to -20.01 dBm/1.23 MHz  
RF Out Only: -109 dBm/1.23 MHz to -10.01 dBm/1.23 MHz

**Composite Signal Output Level Accuracy (AWGN off)**

Standard:  $\pm 1.5$  dB, typically  $\pm 1.0$  dB  
With Option 601:  $\pm 1.8$  dB at 25° C  $\pm 10^\circ$  C, typically  $\pm 1.0$  dB

**Relative CDMA Channel Level Accuracy:** 0.2 dB**CDMA Analyzer****CDMA Average Power Measurement****Input Frequency Range:**

Standard: 30 MHz to 1000 MHz  
With Option 601: 800 MHz to 960 MHz, 1710 MHz to 1990 MHz

**Measurement Range (RF in/out connector only):**

Standard: -10 dBm to +35 dBm (0.1 mW to 3 W)  
With Option 601: -13 dBm to +37 dBm (50  $\mu$ W to 5 W)

**Measurement Accuracy**

Standard:  $\pm 5\%$  of reading  $\pm 1 \mu$ W from 15° C to 35° C  
With Option 601:  $\pm 5\%$  of reading  $\pm 2.5 \mu$ W from 13° C to 33° C

**CDMA Channel Power and Access Probe Measurements**

Measurement Range: -50 to +30 dBm/1.23 MHz  
Calibration: Must be cross calibrated to Average Power Meter

**Access Probe Measurement**

Triggering: Auto-trigger above -55 dBm

**CDMA Modulation Measurement****Input Level Range:**

Standard: -20 dBm to +35 dBm, usable to -25 dBm  
With Option 601: -25 dBm to +37 dBm, usable to -28 dBm  
"  $\rho$  " Measurement Accuracy: "  $\rho$  "  $\pm 0.003$ .

**Frequency Error Measurement Accuracy:**  $\pm 30$  Hz

**Other Reported Parameter with "  $\rho$  " Measurement:** Transmit Time ( $\tau$ , time offset), Frequency Error, Carrier Feedthrough, Amplitude Error, Phase Error

**CDMA Frame Error Rate Measurement**

**FER Measurement Method:** Data loopback using Service Option 002 or 009 supporting Confidence limits per TIA/EIA-98-B

**FER Reported Parameters:** Measured FER, Number of Errors, Number of Frames tested, Pass or Failed Confidence limit

**General Specifications****Dimensions (HxWxD)**

Standard: 177 H x 426 W x 629 D mm (7 in x 16.75 in x 24.75 in)  
With Option 601: 254 H x 426 W x 629 D mm (12 in x 16.75 in x 24.75 in)

**Weight**

Standard: 27 kg, 59 lbs  
With Option 601: 32.6 kg, 72 lbs

**Operating Temperature:** 0° C to +55° C**Power**

**8924E:** 100 V to 240 V, 50/60 Hz, nominally 400 VA  
**83236B:** 90 V to 132 V, 198 V to 264 V, 47 to 63 Hz, 100 VA

8924E

7

N3417A

- Isolates mobile phone from external signals for RF testing
- Operates with the E6392B and 8920 mobile test sets
- Designed for use with the PoST automated test software (E8290A, E8291A, 8292A)
- Built-in antenna coupler, eliminates cabling to the phone
- Anechoic properties, internal RF absorption
- >80 dB RF isolation



N3417A

## Isolates Phone from Interference

The Agilent N3417A Mobile Phone Isolation Box provides an easy and quick way to test cellular and PCS mobile phones. This box allows testing in a sales or service environment saving both time and money.

Most phones that customers bring in can be tested on site, found to be trouble-free, and returned promptly to them. This Mobile Phone Isolation Box, along with one of the Agilent mobile phone test sets and test software, saves you the expense of factory returns, and allows you to recoup the cost of this system, typically within just a few months' time.

The Mobile Phone Isolation Box, with a built-in antenna coupler, allows the test operator to put a phone inside a shielded enclosure, attach the phone to the antenna coupling structure, and start testing—without any use of cabling. The box also provides a highly shielded enclosure, so that there is no interference between the phone being tested and signals from other cellular and PCS networks operating within the vicinity.

## For Use with Agilent Mobile Test Sets and Software

The box is used in conjunction with the PoST (Point of Service) software family, which automatically controls the test equipment and applies all necessary calibrations for mobile phone testing. The isolation box can test nearly all digital and analog phones. Once inside the box, the phone functions as if it were connected to a cellular base station. The mobile phone test software can quickly take the necessary measurements and determine how the phone is performing. Using this system requires only minimal training for any operator and does not require a skilled technician.

Many mobile phone manufacturers specify the performance of their transmitters and receivers at the RF test connector. By using the antenna coupler provided, the operator can get readings at the antenna that are equivalent to the readings at the RF test connector—without attaching anything to the phone itself. This is a dramatically improved method for testing mobile phones.

The calibration structure is built directly into the PoST software, which makes testing much easier. Stored within the software system is a calibration file for each model of phone. Each coupling coefficient in this file compensates for the difference in loss between the antenna coupler and a cabled coaxial connection to the RF test connector. Individual coupling coefficients are also stored for both the uplink (mobile to instrument) and for the downlink (instrument to mobile) paths. Once the new cal factors are entered into the PoST software, the measurements match those with the RF connector, typically to within  $\pm 1$  dB.

The Mobile Phone Isolation Box allows you to perform the same type of testing as with a cable connection and get the same type of accurate readings at a lower cost and with substantially less training of personnel.

## Technical Specifications

### Shielded Chamber

**RF Isolation:** >80 dB typically from 1 MHz to 2 GHz with door latched.

**Internal RF Absorption:**  $Q < 2$  in the 800 to 1000 MHz and 1800 to 2000 MHz bands.

### Antenna Coupler

**Coupling Factor to Resonant Dipole 1" away from coupler surface:**

<8 dB typically from 824 to 894 MHz (U.S. Cellular Band) and

<11 dB typically in the 1850 to 1990 MHz (U.S. PCS) band.

**Coupling Factor to Mobile Phones:** Depends on phone model and antenna type. Actual variations can be calibrated out using PoST software.

**Coupling Factor Repeatability:** Typically  $\pm 1$  dB.

### Connectors

**Antenna Coupler:** Type N Female external.

**Cable calibration connectors:** Type N Female internal and external.

**DC/Audio Connector:** Filtered dB9 internal and external.

## Mechanical Specifications

**External Dimensions:** 3.74 mm H x 5.52 mm W x 7.68 mm D

(9.5 in x 14 in x 19.5 in). Includes latches and connectors.

**Internal Dimensions:** 1.28 mm H x 3.15 mm W x 5.81 mm D

(3.25 in x 8 in x 14.75 in)

### Usable Internal Space:

Maximum Mobile Antenna Length: 7"

Maximum Mobile Phone Length: 7.5v (phone body)

Min/Max Phone Width: 1.75"/3v. Clamp adjustment range.

Maximum Mobile Phone Height: 3.25v

Weight: (Approximately) 8 lbs.



- Low cost GSM/DCS/PCS mobile station test sets
- Designed specifically for service repair environment
- Features repair measurement tools for Go/No Go, troubleshooting, and after-repair calibration applications
- Accuracy and reliability comparable to high end test sets
- Learn to use all functionality in less than 30 minutes

### Lower the Cost of Repairing GSM Mobile Phones

To help service technicians cope with the growing number of mobile phones coming into repair shops, the E6392B GSM mobile station test set provides module-level repair capability for the price of an entry-level “go/no” tester. With the new Agilent test set, GSM service-providers and mobile-phone-repair organizations can increase the capability and effectiveness of their entire service network, extending troubleshooting and repair coverage to local shops while keeping equipment costs in line. They can also reduce the number of “no trouble found” phones that are sent back to the manufacturer.

### Summary of New Enhancements That Help You Succeed

- GSM/DCS dual-band, hand-over test
- PCS 1900 band testing
- 6 TCH channels for flexible automatic testing
- 3v to 11v DC source for MS power consumption/BS PA MFRAME test and battery/charger tuning
- 0.5dB signal generator resolution steps for increased troubleshooting/calibration accuracy
- Memory keys to further facilitate troubleshooting/calibration applications

### Versatile Measurement Tools

The E6392B offers a combination of just-enough functionality, good performance, and a low price. Comprehensive, automatic GSM measurement speeds inspection of incoming mobile phones. With full test capabilities for GSM 900, E-GSM, DCS 1800, and PCS 1900 technicians can check most GSM phones with a single instrument. They can also troubleshoot a problem to the mechanical of module level and make necessary module replacements.

Measurement tools include a direct current (dc) power consumption check, spectrum monitoring capability, and various transmitter and receiver measurements. The test set's built-in functionality includes a dc power supply (standard) and optional spectrum monitor and signal generator. Measurement results are accurate and repeatable. For example, the test set provides a peak power measurement accuracy of  $\pm 0.6$  dB for transmitter measurements.

### Easy to Use and Maintain

Service technicians can learn how to use the GSM test set in about 30 minutes. An intuitive use interface and a PC memory card reader help make the test set easy to set up and operate. Different test conditions can be stored on PC cards for easy uploading into the instrument. Also, Agilent will supply firmware upgrades for the GSM test set on PC cards.

A variety of optional accessories for the GSM test set includes RF cables, RF and dc power adapters, couplers, GSM test SIMs, and a shielded box for testing in open, spectrally noisy environments.

### Transmitter Measurements

- Peak Tx power
- Power versus time
- Burst timing
- Phase error (peak and rms)
- Frequency error

### Receiver Measurements

- Bit error ratio (BER)
- Frame erasure ratio (FER)
- Rx Quality
- Rx Level

### Other Measurements

- MS power consumption
- Speech echo back to mobile station

### Key Specifications

#### RF Signal Generator

##### Frequency Range:

GSM/E-GSM/DCS1800/PCS 1900 downlink frequencies

**Frequency Resolution:** 200 kHz, at channel frequency

**Output Level Range:**  $-110$  dBm to 50 dBm

##### Output Level Accuracy:

$\pm 1.0$  dB at GSM/E-GSM,

$\pm 1.3$  dB at DCS1800,  $\pm 1.5$  dB at PCS 1900

#### RF Analyzer

##### Frequency Range:

GSM/E-GSM/DCS1800/PCS1900 uplink frequencies

#### Transmitter Carrier Peak Power Measurement

##### Accuracy:

$\pm 1.0$  dB ( $\pm 0.6$  dB typical at  $25^\circ\text{C} \pm 5^\circ\text{C}$ ) at  $\geq 0$  dBm

$\pm 2.0$  dB ( $\pm 1.6$  dB typical at  $25^\circ\text{C} \pm 5^\circ\text{C}$ ) at  $< 0$  dBm

**Resolution:** 0.2 dB

#### Phase Error Measurement Accuracy:

$\leq 1.5^\circ$  rms at phase error  $\geq 2.5^\circ$

$\leq 6.0^\circ$  peak at phase error  $\geq 2.5^\circ$

#### Frequency Error Measurement Accuracy

(average of 10 measurements):

$\pm(10$  Hz + frequency reference accuracy) at GSM/E-GSM

$\pm(25$  Hz + frequency reference accuracy) at DCS1800/PCS 1900

#### DC Power Supply

**Range:** 3 Vdc to 11 Vdc

**Resolution:** 0.1 V

**Accuracy:** 0.1 V at 100 mA load

#### DC Current Measurement

**Range:** 3 mA to 1000 mA

**Accuracy:**  $\pm(3$  mA +2% of reading)

GSM 900  
DCS 1800  
PCS 1900

# Wireless Mobile & Base Station Test Sets

374

## CDMA, IS-136, AMPS, Point-of-Service Test GSM Software

E8290A  
E8291A  
E8292A  
E8293A

- Verify phone performance
- Reduce number of “no trouble found” phones
- Analyze and store data for trend-analysis and customer-care applications
- Point-and-click operation for non-technical users
- Comprehensive measurement capabilities for test developers



7

E8290A, E8291A, E8292A, E8293A

### Point-of-Service-Test for CDMA, IS-136, AMPS, and GSM Phones

To help mobile-phone retailers, wireless service providers, and repair organizations minimize costs; the family of Point-of-Service-Test (PoST) software packages provides quick and easy verification of the performance of CDMA, IS-136, AMPS and GSM mobile phones.

With minimal training, sales clerks and other non-technical personnel can initiate and make fast, accurate measurements of phones, finding “no trouble found” phones quickly, thus reducing the number of phones returned to manufacturers. With the easy-to-use, mouse-driven, Windows-based interface, phone problems can be evaluated quickly at a retail store or local service center. With a password protection for software screens, development-mode technical screens can be hidden from non-technical staff, effectively making the PoST software less intimidating.

Yet, in the development mode, technical users can access the capabilities to create customized tests for different phone models. Test plans, as well as test specifications and parameters, can be set up and customized with ease.

#### Data analysis capability

To help reduce customer churn and improve customer care, PoST software provides detailed, accurate performance data that can be exported in popular PC databases and spreadsheet formats for use in trend analysis. For example, by collecting, merging and analyzing the information from each of your retail store’s PoST software databases; it may be possible to identify problems in particular phone models. Recurring customer comments may identify problem areas in network operation.

The combination of the PoST software and Agilent’s test sets is a practical test solution for the service providers’ mobile quality and repair groups, and verification labs.

The PoST software family utilizes CDMA, TDMA, AMPS, and GSM Agilent mobile station test sets:

- CDMA/AMPS PoST (E8290A)  
8924E  
E8285A
- TDMA/AMPS PoST (E8291A)  
8920B
- GSM/DCS/PCS PoST (E8292A)  
E6392A/B
- GSM/DCS/PCS PoST (E8293A)  
8922M/P

#### System Requirements

- An IBM (or compatible) PC with at least:
- 166 MHz Pentium processor
- Microsoft Windows NT 4.0 or Windows 95/98
- 16 MB of RAM
- 20 MB of available hard disk space

#### Ordering Information

- E8290A** CDMA/AMPS PoST Software
- E8291A** TDMA/AMPS PoST Software
- E8292A** GSM/DCS/PCS PoST Software
- E8293A** GSM/DCS/PCS PoST Software

- Complete GSM/DCS/PCS mobile station test sets
- Designed to minimize production/service costs
- Built-in toolkit of instruments
- E-GSM and dual-band capability
- Fast and easy to use
- HSCSD Test Solution
- Accurate and repeatable GSM measurements
- Built-in IBASIC controller for easy automation



8922M  
8922P  
83212D  
83220A/E

8922M

### 8922 GSM Test Sets

The 8922 GSM MS Test Set is ideal for use in R&D, high-end service and manufacturing. The easy to use, rich and flexible feature set make it the instrument of choice for bench work. The speed, accuracy and repeatability of the 8922 make it ideal for use in incoming inspection and volume manufacturing. The 8922 includes a GSM base-station emulator and all the signalling and measurement capability to fully test a mobile without any additional equipment.

### GSM Radio Test Solutions

The 8922 contains a complete set of instrumentation for testing the RF sections of GSM radios. In addition to the frequency agile 0.3 GMSK RF generator, the RF analyzer has an agile local oscillator, coherent data demodulator, pulse demodulator, FM demodulator, global method analyzer for phase and frequency error, synthesized spectrum analyzer, and pulse power meter. The 8922 adds a bit-error-rate tester (BERT) for performing GSM receiver measurements, channel CODEC, and call control protocol to setup a phone call and maintain the link while performing measurements. Echo mode is facilitated by the voice CODEC for functional testing of a mobile, and the electrical man machine interface (EMMI) is implemented for controlling the mobile and supporting the digital audio interface (DAI). Flash memory on the 8922 allows easy upgrades.

### GSM Data and HSCSD Test Solution

The 8922 supports the ability to test GSM single slot data and High Speed Circuit Switched Data (HSCSD) mobiles. For use in R&D, Production and Service, options K09, K17 and K18 can test single slot, 2x1, 2x2, 9.6Kbps and 14.4Kbps mobiles.

### Complete Tool Set

Aside from their complete complement of GSM measurements, the 8922 contains general-purpose tools useful for module test, troubleshooting, and debugging activities. The tools include a digital oscilloscope, CW RF synthesizer, spectrum analyzer, CW RF frequency counter, CW and peak RF power meter, ac voltmeter, dc voltmeter, 1 kHz distortion/SINAD meter, audio frequency counter, and synthesized audio source. The sum of these capabilities makes the 8922 an extraordinarily powerful tool for the design manufacture and repair of GSM radio equipment.

### 83212D GSM/DCS1800/PCS1900 Mobile Test Software

The 83212D is an easy-to-use software solution for automatic testing of GSM900, DCS1800 and PCS1900 mobile stations. Running on the 8922's built-in IBASIC controller, the 83212D offers a comprehensive set of tests ideal for incoming inspection and repair of GSM phones. Its flexibility and modularity allow you to select and change test sequences, test parameters, and pass/fail limits without programming expertise. Procedures can be simply saved on RAM cards and distributed to colleagues, guaranteeing consistent test methods. All test results are displayed on the screen and can be documented with hard-copy printouts when an external printer is added. Three levels of testing are available with the 83212D: manual mobile station troubleshooting, quick functional checkout, and full parametric testing. Automating your measurements provides repeatable results while allowing the user to test more mobile stations in less time. This increase in throughput lowers your testing cost.

### 83220A/E DCS/PCS Test Sets

The 8922M tests GSM mobiles only. Adding an 83220A/E expands the capabilities of the 8922M to comprehensively test DCS1800 and PCS1900 equipment. The 83220E provides a cost-effective solution for mobile testing. The 83220A has the frequency range to test both mobiles and base stations. All features of the 8922 are retained.

### 8922P Dual-band Test Sets

Combine the 8922M with the 83220E and new firmware to form a complete dual-band (GSM 900/DCS 1800) test solution. All the original 8922 features are retained but now, with dual-band intra-cell handover capability, the latest GSM mobiles can be tested seamlessly, at all frequencies, through a single RF connector.

8922M  
8922P  
83212D  
83220A/E

## 8922M Specifications

### RF Generator

**Frequency Range:** 10 MHz to 1000 MHz  
**Frequency Resolution:** 1 Hz  
**Switching Speed:** 577  $\mu$ s  
**0.3 GMSK Modulation:** External clock and data  
**Pulse Modulation:** Normal and 30 dB  
**Output Power:** -16 to -127 dBm

### RF Analyzer

**Frequency Range:** 10 MHz to 1000 MHz  
**Frequency Resolution:** 1 Hz (100 kHz in hop mode)  
**Switching Speed:** 577  $\mu$ s  
**Coherent Data Demodulation:** 0.3 GMSK at 270.833 Kb/s, 1 timeslot/frame  
**Analog Demodulation:** FM and pulse  
**Global Method:** rms and peak phase error, frequency error  
**Amplitude Envelope:** Rise, fall, and burst flatness over useful bits  
**Peak Transmitter Power:** +10 dBm to +45 dBm (-5 dBm to 41 dBm on 8922F/H)  
**Output RF Spectrum Measurements<sup>1</sup>:** Due to modulation and switching transients  
**CW Frequency Counter:** 10 MHz to 1000 MHz

### Spectrum Analyzer<sup>1</sup>

**Frequency Range:** 10 MHz to 1000 MHz  
**Frequency Accuracy and Stability:** Same as timebase  
**Display Range:** 80 dB  
**Other Features:** External trigger, marker

### Digital Oscilloscope

**Frequency Range:** 2 Hz to 50 kHz  
**Sweep Times:** 10  $\mu$ s to 100 ms in 1, 2, 5, 10 steps

### Audio Analyzer

**Frequency Range:** 20 Hz to 400 kHz  
**AC Voltage Range:** 0 to 30 V<sub>rms</sub>  
**DC Voltage Range:** 100 mV to 42 V  
**THD + Noise:** 1 kHz  $\pm$  5 Hz  
**Sinad:** 1 kHz  $\pm$  5 Hz

### Audio Source

**Frequency Range:** DC to 25 kHz  
**Output Level Range:** 0.1 mV<sub>rms</sub> to 4 V<sub>rms</sub>

### Reference Oscillator

**External Reference Input Frequency:** 13, 10, 5, 2, or 1 MHz  
**External Reference Output:** 10 and 13 MHz

### Remote Programming

**GPIB:** IEEE-488.2  
**RS-232:** 300, 1200, 2400, 4800, 9600, and 19200 baud

### Internal Programming

**Programming Language:** Instrument BASIC  
**Program Storage:** 32 KB to 512 KB external memory cards

### General Specifications

**Size:** 177 mm H x 426 mm W x 574 mm D (7 in x 16.75 in x 23 in)  
**Weight:** 32 kg (70 lb)  
**Operating Temperature:** 0° C to +55° C  
**Storage Temperature:** -40° C to +75° C  
**Power:** 100, 120, 220, 240 Vac, 48 to 440 Hz,  $\pm$ 10% of line voltage

### GSM Functionality

**Broadcast Channel Capability:** BCCH + CCCH or BCCH + CCCH +SDCCH/4  
**Control Channels:** BCCH + CCCH, BCCH + CCCH + SDCCH/4, SDCCH/8 (non-hopped), SACCH/FACCH  
**Traffic Channels:** TCH (FS/EFS)  
**Call Control Capabilities:** BS originated call (FS/EFS), MS originated call (FS/EFS), MS camp on, BS call disconnect, MS call disconnect  
**Timing:** Auto, manual, uplink-downlink offset measurement  
**Hopping:** Cyclic only, two MA tables with offsets  
**Digital Audio Interface (DAI):** Normal operation and test of acoustic devices and A/D & D/A  
**Electrical Man Machine Interface:** Control via GPIB  
**Speech Encoding/Decoding:** Full rate speech (FS)  
**Echo Mode:** 8922M: user selectable delay, 0 to 5 seconds  
**Bit/Frame Error Rate Measurements:** Class Ia, Ib, and II bits. New fast BER measurement has been added.  
**MS Power Output Level Control:** 0 to 19, 30, 31 with RF analyzer auto adjust  
**Measurement Coordination:** Flexible control of burst, ARFCN, and timeslot  
**SACCH MEAS Results:** RXLEV, RXQUAL, timing advance  
**SMS Cell Broadcast, IMSI attach/detach**  
**HSCSD Test Solution**

### GSM Reference

**External Reference Input Frequencies:** 13, 10, 5, 2, 1 MHz, bit clock, or frame clock

### 83220E Specifications

**Frequency Range:** 1805 to 1990 MHz

### Ordering Information

**8922M** GSM MS Test Set  
**8922P** Dual-band Test Set  
**83212D** GSM Test Software  
**83220A** DCS/PCS Test Set with aux.ports  
**83220E** DCS/PCS Test Set  
**Options for 8922**

- Opt 001** High-Stability Timebase
- Opt 006** Spectrum Analyzer
- Opt 007** 3v/5v Test SIM Card
- Opt 008** 3v/5v Test Micro SIM Card
- Opt 012** 83212D GMS MS Test Software
- Opt W30** 3 years Return Repair Service

#### Options for 83220A/E and 8922M

- Opt 0B1** Provides a total of two sets of Users Guides and Service Manuals (Users Guide only for A/E)
- Opt AX4** Rackmount Flange Kit
- Opt 0B3** Adds Service Manual

<sup>1</sup>Requires Option 006, Spectrum Analyzer, on 8922M



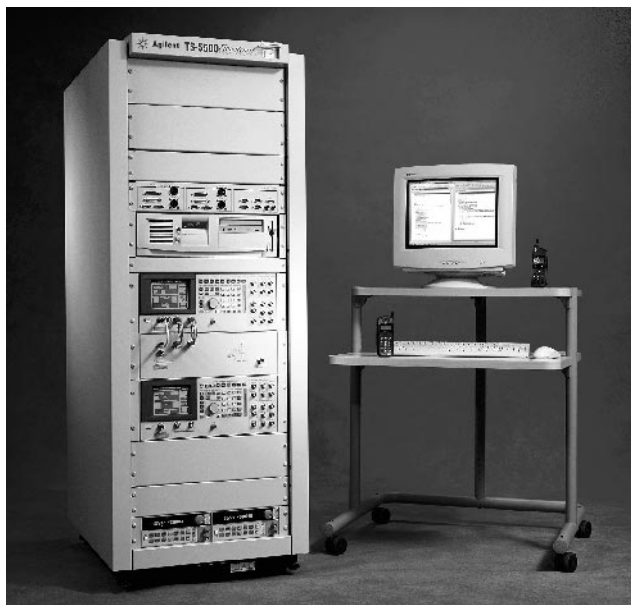

### TS-5500 Cellular Phone Functional Test Platform

The TS-5500 Platform concept provides a universal test system core of both hardware and software, which can be easily modified to suit various cellular phone manufacturing test stages. Test system developers can customize the use of instruments and test routines to create a specific test stand. The TS-5500 Functional Test Platform can decrease test times, decrease floor space, and lower your test equipment costs, while getting your product to market faster.

The TS-5500 is a family of test platforms offering choices to meet a variety of test situations. The TS-5530 is a simple, cost effective test platform, ideal for manufacturers with semi-automated needs or starting in production. The TS-5550 provides more flexibility of measurements and inputs/outputs with the incorporation of VXI.

### TS-5500 is Measurement-Ready for Cellular Phone Testing Requirements

Testing GSM, CDMA, or TDMA Cellular Phones requires certain instruments for the specific tests and integration of this equipment into the manufacturing line. The TS-5500 has the best measurement equipment integrated with the software to do the job.

Turn-on tests of the cellular phone at board-level would include emulating the battery requirements, testing battery charging circuitry, probing points on the board and communicating to the phone. Agilent's Dynamic Measurement Power Supplies are designed for cellular phone battery emulation and testing.

Calibration tests involve adjusting power levels in the phone circuitry to be able to make a phone call. For these RF measurements, the TS-5500 uses one GSM test set (8922M/P or 8960), or TDMA Test Set (8920B or 8960) for each phone. Today, the Agilent's family of RF test sets is a core part of the system to produce quality phones at the best throughput and lowest cost.

Final test verifies a sequence of standard radio tests using the RF Test Set as the core measurement instrument. Other final tests include audio tests of the microphone and speakers.

With the high volumes of cellular phone manufacturing, computer-aided-test is of high value. The TS-5500 uses a single PC for controlling the instruments, running the tests, and interfacing to automation equipment. The Agilent TestExec SL software test executive, radio measurement routines, software utilities, and an operator interface are provided.

### TS-5500 System Lowers Integration Costs

Agilent integrates the functional test system to lower costs, since Agilent standardizes the racking, cabling, and mass interconnect. The economies of scale at Agilent provide a lower cost than one-of-a-kind integration by each test engineering project team. This more complete solution also eliminates steps in test development. Since

one TS-5500 handles up to four phones with a minimum of one rack of equipment, integration costs are reduced versus building separate racks for each phone.

The TS-5500's ExpressConnect is a common, standardized connection point for the test fixtures, as well as system resources and instrumentation. While it is designed for up to four UUTs on the multiple-up testers, the Agilent ExpressConnect scheme is used on all configurations. All the system's non-RF resources are brought to the Agilent ExpressConnect.

### TS-5500 Software Increases Productivity

The TS-5500 software is a complete test development and test execution environment for the entire software development job. Agilent TestExec SL is tuned for functional testing of electronic devices in manufacturing. The software runs on a PC with Windows NT for optimum performance and it's pre-installed and ready to use. The TS-5500 software provides maximum re-use as a result of its hierarchical environment.

The TS-5500 Software Development Environment is for developing tests for cellular phones. It consists of reusable tests, measurements, and utilities for performing specific functions related to GSM, CDMA, and TDMA phone testing. Templates and examples are provided to serve as a starting point for creating tests. The Agilent test executive allows you to organize and order tests, reconfigure the test stand, profile the execution speed, and debug tests. The Agilent-supplied library of tests, measurements, and utilities for GSM, CDMA, and TDMA cellular test are tuned for measurement performance.

The TS-5500 Software Test Execution Environment allows an operator to test up to four phones simultaneously and reports test information back to the operator. Using the software utilities, you can easily link the test executive with factory automation, bar code readers, and printers. This operator interface panel is created by the test developer. Agilent provides a sample operator interface that is easily modified, or you can use Visual Basic to quickly develop a custom operator interface.

### Documentation, Training, and Support

Documenting a system can be difficult when test engineering's primary job is to keep production up and running. TS-5500 provides complete documentation of its unique capabilities: cabling, mass interconnect, power distribution, and software. Agilent also offers training on the system platform to augment its extensive curriculum. Worldwide support on the hardware components and the unique platform features is provided by Agilent's team. When you deploy a system, all you have to worry about documenting and supporting is your customization of the platform.

### Pre-built System Platform Cuts Development Time

From the universal TS-5500 Platform, you'll need to complete the system integration by adding the application specific software, fixturing, factory automation, robotics, etc. For example, test developers must add the appropriate phone communications and can customize the operator interface. Test programs and test plans need to be developed for the specific phones undergoing testing.

Agilent offers a complete range of services to complete the TS-5500. Agilent is experienced at building test systems for cellular phone manufacturers. We've provided project management, software, fixtures, robotics, automation, and vision systems. Additionally, Agilent has completed many projects that involve creating operator interfaces, final test programs, specific phone communications, and custom circuitry.

### Ordering Information

**E8431A** TS-5530 One-up Base System  
**E8432A** TS-5530 Two-up Base System  
**E8452A** TS-5550 Two-up Base System  
**E8453A** TS-5550 Three-up Base System  
**E8454A** TS-5550 Four-up Base System

Additional instrumentation and configuration choices must be added with system options.

**E2181A** TS-5500 Family Options

TS-5500

7

TS-50



## TS-50 RF/Mobile Phone Test Fixtures

The Agilent TS-50 Family of RF/Mobile Phone Test Fixtures provides a test fixture solution for mobile phones, phone printed circuit boards (PCB), as well as other RF/wireless devices. The TS-50 Fixtures are complete fixtures in kit form, containing key components to create reliable, high-quality fixtures.

For phones, test system developers need only add connections, such as the phone's system connector, battery connections, and/or RF antenna. For PCBs, a probe plate and probes for the specific board need to be created (an optional Board Test Adapter Kit or product supplied by the board-test fixture vendor can be used).

TS-50 Family Fixtures are highly versatile and adaptable fixtures, designed to work optimally with Agilent test equipment—e.g., the RF Test Sets and the TS-5500 Cellular Phone Functional Test Platforms. However, the TS-50 Family will also work with other manufacturers' RF or mobile phone testers, offering the widest use flexibility possible.

### Pre-Built Solution for Fast Fixture Development

The TS-50 creates a custom fixture for testing virtually any assembled phone, RF device, or phone PCB. To complete the fixture nest, simply attach the phone's system connector to the cable and the cable to the internal connectors. The RF connection from the phone feeds through the fixture to the RF test equipment. To add optional audio capability, attach the speaker and microphone to the fixture and position them over the nest. For both the assembled-phone and phone PCBs, the shielded RF enclosure and routing of test system resources are done in advance.

### Fast, Safe Semi-Automatic Test

Semi-automatic (human-loaded) testing of mobile phones and PCBs is made fast and easy with TS-50 fixtures. The test operator opens the lid, connects the phone to the cable(s), places the phone in the cradle, closes the lid, and presses START on the test system. Once the test is complete, the operator removes the phone and inserts a new one. When doing a phone PCB test, the operator closes the lid, which automatically pushes the probe pins into the appropriate junctures on the PCB. Pneumatics are not required; mechanical action alone creates stable, reliable connections.

### Fixture Re-Use Capability Reduces New Design and Development Costs While Compact Size Offers Low Maintenance

The TS-50 fixture can be reconfigured and used with new products without redesigning a new test fixture for every new phone, by simply adding new cables to the phone and adjusting the phone nest. For a new PCB, the board fixture can be reused by using pins to create a new probe plate.

The TS-50 fixture's design and reliable mechanisms minimize test and production downtime. This fixture has a proven track record as it is based on Agilent's custom fixture designs for the past few years. The cable(s) to the phone is the only part that must be

replaced on a regular basis—the exact maintenance cycle is based on the phone connector. A loop-back cable provided with the TS-50 allows for maintenance and diagnostics testing from the tester through the internal circuitry and back to the test system.

The small size of the TS-50 fixture—275 mm H x 300 mm W x 450 mm D (10.83 in x 11.81 in x 17.7 in)—allows for two fixtures to be placed side by side in front of a standard 482.6 mm (19 in) rack. Inside, the fixture has space to test phones or other RF devices as large as 300 mm H x 90 mm W x 45 mm D (11.81 in x 3.54 in x 1.77 in).

### Family of RF Enclosures

The TS-50 RF Enclosure model E8704B is the RF-shielded enclosure that can be used in testing many RF devices, including phones. The E8704B can easily be adapted for many different test systems by adding specific TS-50 options. The E8704B includes an enclosure shell, rear cover plate with one 25-pin D-Sub connector and one N-Type RF connector, one blank rear cover plate and nest base plate.

The TS-50 Final Test Fixture model E8705B is the RF-shielded enclosure that is used in testing assembled phones. Options necessary for nesting, signal routing, audio connections, and cabling to the TS-5500 test systems are available. The E8705B includes an enclosure shell; fixture electronics board for routing phone signals, level-shifting, and filtering signals; a rear cover plate with one 9-pin, one 15-pin, and one 25-pin D-Sub connector and one N-Type RF connector; and an RF absorber nest environment to eliminate standing waves and reflections.

The TS-50 Board Test Fixture model E8706B is the RF-shielded enclosure used in testing wireless/RF PC boards, including phone PC boards. A board press mechanism is the base for holding the PC board. Options are available for probe pin kits, signal routing, and cabling to the TS-5500 test systems. The E8706B includes an enclosure shell, board press mechanism, and rear cover plate with connectors and one N-Type RF connector.

### Agilent TS-50 Fixture Options and Characteristics

Options	E8704B	E8705B	E8706B
<b>Opt 001</b> Fixture Electronics Board	N/A	Included	Optional
<b>Opt 002</b> Audio Kit	Optional	Optional	N/A
<b>Opt 003</b> Quick Nest Kit	Optional	Optional	N/A
<b>Opt 005</b> RF Absorber Nest	Optional	Included	N/A
<b>Opt 006</b> Blank Rear Plate	Optional	Optional	Optional
<b>Opt 030/050</b> Cables for TS-5500/TS-5530	N/A	Optional	Optional
<b>Opt S01</b> Fixture Service Kit	Optional	Optional	Optional
<b>Weight Including Standard Options</b>	~16 lbs	~27 lbs	~20 lbs

RF Shielding	E8704B <sup>1</sup>	E8705B <sup>2</sup>	E8706B <sup>3</sup>
600 MHz to 2.5 GHz (dB)	>50 dB	>65 dB	>45 dB
800 MHz to 1.0 GHz (dB)	>60 dB	>65 dB	>60 dB
1.7 GHz to 2.0 GHz (dB)	>50 dB	>65 dB	>50 dB

<sup>1</sup> E8705B was tested without options or cables.

<sup>2</sup> E8705B was tested with RF Absorber and Fixture Electronics Board Options installed and TS-5530 cables attached.

<sup>3</sup> E8706B was tested with Board Press and Fixture Electronics Board Options installed and TS-5530 cables attached.

For special customization requirements, start with the TS-50 RF Enclosure and design the cabling, nest, and other electronics. Agilent can provide design and implementation services to tailor the fixture enclosure to suit specific needs.

### Automated Custom Fixturing for Test of Wireless Products

Agilent has developed common fixture platforms that can be tailored to the handling and testing requirements of virtually any wireless product. From simple circuit elements to final assemblies, these automated or manual handling test fixture solutions save time and money, and reduce risk by offering upgradability for future test requirements. For more information, contact your local Agilent Technologies representative.

- Multiformat capability
- One-button W-CDMA, cdma2000, cdmaOne, EDGE, GSM, NADC, PDC, and iDEN measurements
- Spectrum and time domain waveform analysis capability



E4406A

### E4406A VSA Transmitter Tester

The E4406A VSA transmitter tester is a full-featured transmitter tester designed to meet the test needs of wireless equipment manufacturers. The VSA provides a wide range of digital modulation analysis capability in an easy-to-use format. The advanced digital demodulation capability makes the VSA an excellent tool for doing R&D on third generation cellular systems. The multiformat capability of the VSA makes it ideal for a flexible production line. Measurements are accessible at the touch of a button and are easily configured with the simple, straight-forward menu structure. The VSA comes standard with the following measurement capability:

- Spectrum (frequency domain) analysis
- Channel power
- Waveform (time domain) analysis
- Occupied bandwidth
- Adjacent channel power (ACP)
- Complementary cumulative distribution function (CCDF)

For the latest on our 3G enhancements to the E4406A VSA, please visit our web site: [www.agilent.com/find/vsa](http://www.agilent.com/find/vsa)

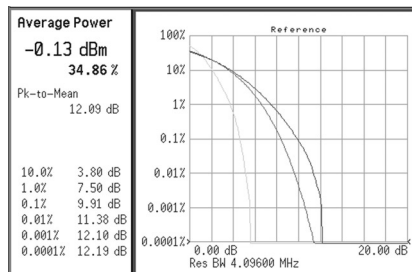

Complementary cumulative distribution function curves

### cdmaOne Personality

Built on Agilent's pioneering efforts in CDMA measurement techniques, the E4406A lets you quickly and efficiently make cdmaOne measurements. New enhancements to the ACPR measurement allow for increased dynamic range. The transmitter tester performs tests to the requirements of industry standards, such as IS-95, and ANSI J-STD-008 specifications.

### cdmaOne Measurements

- Channel power
- Modulation accuracy (Rho)
- Adjacent channel power ratio (ACPR)
- Code domain analysis
- Close-in spurious analysis

### cdma2000 Personality

The cdma2000 personality provides key transmitter measurements for analyzing systems based on the IS-2000 standard. New enhancements to this personality enable the demodulation of the HPSK reverse-link signals. The advanced code domain analysis algorithms allow the Walsh codes to be displayed for either Haddamard or OVVSF coding schemes resulting in composite multi-rate views. The decoding algorithm automatically determines active channels of any code layer. The active channel identification allows engineers to examine and analyze unknown signals with ease. The ability to decode heavily loaded signals means engineers can evaluate and stress test their transmitter. The composite EVM feature enables engineers to perform EVM measurements for the pilot and other channels.

### cdma2000 Measurements

- Channel power
- Adjacent channel power ratio (ACPR)
- Spectrum emission with mask
- QPSK EVM
- Inter-modulation (IM) distortion measurements
- Power statistics using the complementary cumulative distribution function (CCDF)
- Code domain analysis
- Composite EVM
- Occupied bandwidth
- Symbol EVM

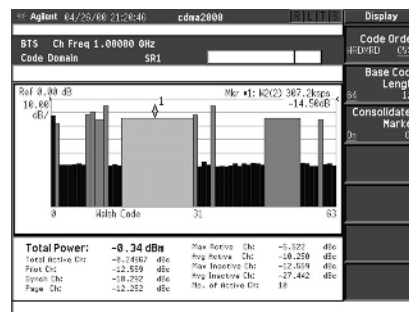

cdma2000 code domain power measurement

### W-CDMA Personality

The W-CDMA personality provides key transmitter measurements for analyzing systems based on the 3GPP standard. New enhancements to this personality enable the demodulation of the HPSK uplink signals and downlink QPSK signals. The system automatically determines active channels on any code layer. It can display the code domain power information in a composite multi-rate view. The composite EVM measurement capability enables engineers to perform EVM measurements for the perch signal and other channels.

### W-CDMA Measurements

- Channel power
- Multi-carrier power measurements
- Spectrum emission with mask
- Occupied bandwidth
- Adjacent channel leakage ratio (ACLR)
- Inter-modulation (IM) distortion measurements
- Power statistics using the complementary cumulative distribution function (CCDF)
- Code domain analysis
- Composite EVM
- QPSK EVM
- Symbol EVM

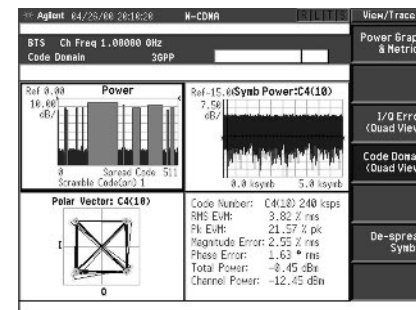

W-CDMA composite EVM measurement



E4406A

## GSM Personality

The E4406A VSA's GSM measurement personality lets you quickly and efficiently perform GSM measurements. The VSA provides capability to completely characterize GSM400, GSM800, GSM900, DCS1800, and PCS1900 transmitters for GSM requirements.

### GSM Measurements

- Mean TX carrier power
- Power versus time (PvT)
- Output RF spectrum (due to modulation and transients)
- Phase and frequency error
- Transmit spurious
- Receive spurious

## EDGE Personality

The new EDGE capability in the E4406A enables you to quickly and easily make one-button standards compliant measurements. The advanced demodulation algorithms allow the user to rapidly view an EDGE constellation diagram and display the EVM results using the industry standard specified measurement filter. The E4406A provides capability to completely characterize GSM400, GSM800, GSM900, DCS1800, and PCS1900 transmitters for GSM requirements.

### EDGE Measurements

- EVM
- Power versus time (PvT)
- Output RF spectrum (due to modulation and transients)

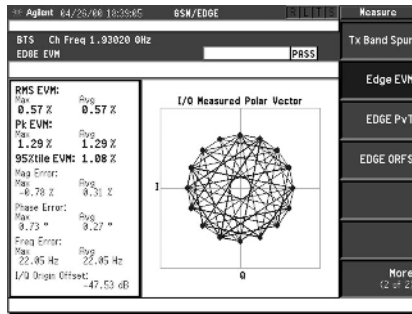

EDGE EVM Measurement

## NADC/PDC Personality

The NADC/PDC personality provides transmitter measurements for both the North American Digital Cellular (NADC) time-division multiple access radio system and the Personal Digital Cellular (PDC) time-division multiple access radio system at both cellular and PCS frequencies.

### NADC measurements

- ACP
- Modulation quality

### PDC Measurement

- ACP
- Modulation quality
- Occupied bandwidth

## E4406A VSA Key Features

- Multifunction capability
- User upgradeable firmware
- GPIB, LAN, and parallel interfaces standard
- High stability timebase standard
- SCPI instrument command language
- Large high-resolution color LCD display
- One-button measurements
- Softkey/hardkey user interface
- Flexible card cage instrument architecture
- Built-in 3.5-inch disk drive
- VXIplug&play drivers

## E4406A VSA—A whole product solution

To provide you with a whole product solution and protect your investment in the E4406A VSA Series transmitter tester, Agilent provides:

- Standard three-year global warranty with optional extension to 5 years
- Customer education available on the product and popular wireless communications technologies
- Worldwide Call Center and Service Center support network
- PC-based performance verification and adjustment software available with optional response center support and update service
- GPIB, parallel and LAN interfaces for connectivity with computers and printers
- VXIplug&play instrument drivers

Tools available at [www.agilent.com/find/vsa](http://www.agilent.com/find/vsa)

## Physical Specifications

**Weight:** 19 kg (42 lb) net  
**Dimensions:** 177 mm H x 426 mm W x 432 mm D  
 (7.0 in x 16.8 in x 17 in)

## Key Literature

- E4406A VSA Transmitter Tester Brochure, p/n 5968-7618E
- E4406A VSA Transmitter Tester Technical Specifications, p/n 5968-3030E
- Self-Guided Demo for the E4406A VSA, p/n 5968-7617E

## Ordering Information

### E4406A VSA Series Transmitter Tester

- Opt BAF** W-CDMA measurement personality
- Opt B78** cdma2000 measurement personality
- Opt BAC** cdmaOne measurement personality
- Opt 202** EDGE (with GSM) measurement personality
- Opt BAH** GSM measurement personality
- Opt BAE** NADC, PDC measurement personality
- Opt 300** 321.4 MHz LO output



# Cellular/PCS Transmitter & Receiver Test Equipment

## Measurement Personalities for the ESA-E Series Portable Spectrum Analyzers

- One button-cdmaOne and GSM measurements
- Root cause analysis and troubleshooting
- Rugged and portable for field use

### Transmitter Testing Measurement Personalities

Transmitter test measurement personalities customize the ESA-E series spectrum analyzers by adding industry standard one-button test capability. The versatile ESA-E series cardcage architecture and floppy disk drive makes it easy to add application-specific measurement hardware and software. The rugged, portable ESA-E series spectrum analyzers with optional measurement personalities and battery pack are ideal for onsite testing of transmitters in the most demanding environments.



E4402B

### ESA-E Series with cdmaOne Measurement Personality

Simplify your measurements of cellular, PCS and other spread spectrum transmitters based on cdmaOne standards. The ESA-E series measurement personality provides both frequency- and modulation-domain measurements including digital demodulation for rho and code domain measurements. The functionality also includes in-and-out-of-band spurious measurements.

#### Measurements

- Channel power
- Receive channel power
- Modulation quality (rho)
- Code domain power
- Spurious emissions in- and out-of-band
- Occupied bandwidth
- Harmonics
- Monitor channel/band
- ACPR

#### Recommended Configuration

E4402B, E4404B, E4405B, or E4407B portable spectrum analyzer with the following options:

- Opt BAC cdmaOne measurement personality
- Opt B74 RF and digital communications hardware

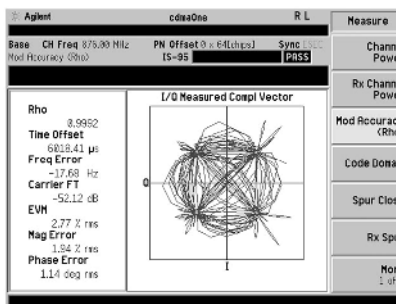
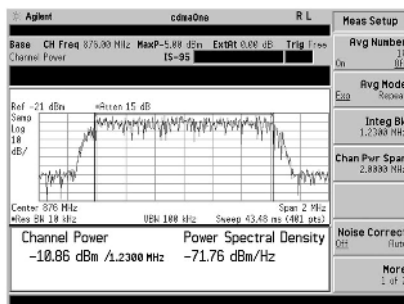

### ESA-E Series with GSM Measurement Personality

Making complex GSM measurements is easy using the ESA-E series spectrum analyzer with the GSM measurement personality. One-button tests verify the performance of GSM transmitters for P-GSM, E-GSM, R-GSM, DCS1800, and PCS1900 systems.

#### Measurements

- Transmit power
- Phase and frequency error
- Output RF spectrum
- Power versus time
- Spurious emissions in- and out- of-band
- Distance to fault (requires optional tracking generator)
- Monitor/channel band
- Power steps

#### Recommended Configuration

E4402B, E4404B, E4405B, or E4407B portable spectrum analyzer with the following options:

- Opt BAH GSM measurement personality
- Opt B74 RF and digital communications hardware
- Opt 1DN Tracking generator (for distance to fault)

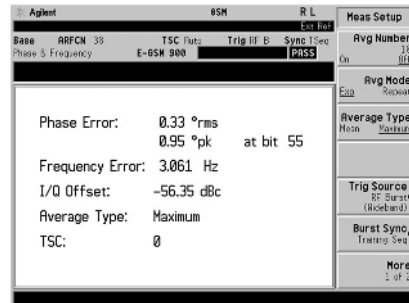
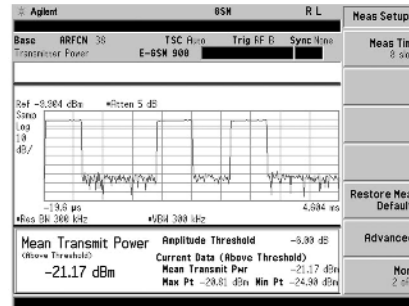

- E4402B
- E4404B
- E4405B
- E4407B

# Cellular/PCS Transmitter & Receiver Test Equipment

## Measurement Personalities for 8590 Series Spectrum Analyzers

Overview

- One-button measurements customized for your application
- Easy to use
- Solutions available for: CDMA, GSM, DCS1800, PCS1900, DECT, CT2-CAI, NADC-TDMA, PDC, PHS

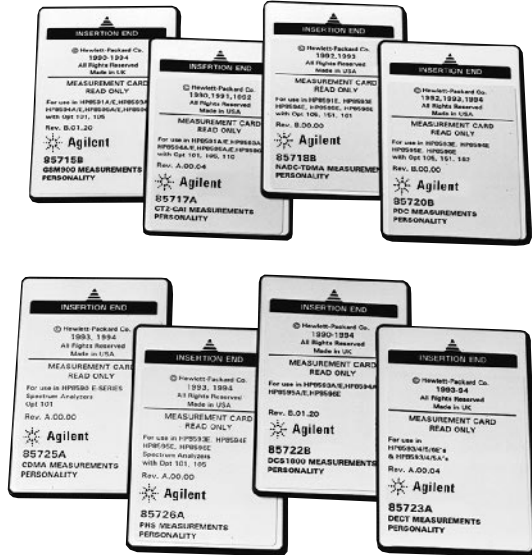

### Measurement Personalities for Customized Transmitter Testing

Measurement personalities are software programs provided on ROM-based memory cards that customize your 8590 series spectrum analyzer to perform complex transmitter tests simply and quickly with the push of a button from easy-to-follow screen menus. They automatically set the analyzer controls and perform calculations required to test to the industry standard for the communications format.

#### Quick, Easy, One-Button Measurements

Using a measurement personality with an 8590 series spectrum analyzer reduces complex transmitter systems or component measurements to single-button operations. Easy-to-use softkey menus are labeled with familiar format-specific measurement names.

#### Power, Frequency, Timing, and Modulation Accuracy

With a properly configured spectrum analyzer, most personalities allow you to perform power-, frequency-, timing-, and modulation-accuracy measurements of your signal. Measuring modulation quality for some of the formats requires a digital demodulator option in the spectrum analyzer; for example, error vector magnitude (EVM) for  $\pi/4$  DQPSK signals of NADC-TDMA, PDC and PHS, and global phase and frequency error for 0.3 GMSK signals of GSM900, DCS1800, and PCS1900. There are other demodulator option cards for the spectrum analyzer for the 0.5 GFSK signals of CT2-CAI and DECT.

### Product Development and Production Troubleshooting

Evaluate your design and thoroughly troubleshoot failures. Measurements can be run continuously, allowing real-time equipment adjustments and troubleshooting. Waveform and graphical results add key visual information to numerical results. Pass/fail messages draw attention quickly to system problems. Test limits can be modified from the front panel, external keyboard, or computer so that you can set your own test goals.

#### High-Speed Production Testing

Reduce costs with increased test throughput. Since all of the customized measurements are programmable, each is executed with a single command. We've written the code for you.

#### Reliable Accuracy

Most of our solutions offer an improved amplitude accuracy option on the spectrum analyzer, so you can measure your transmitters with near-power-meter accuracy.

#### Features to Make Your Measurements Easier

The measurement personalities contain one or more added features to make your measurements even easier such as automatic tuning by channel number, frequency-band monitoring, and combiner tuning. The newest addition to Agilent's portfolio of measurement personalities for transmitter testing, the 85725C for CDMA, has an on-screen help feature to guide you through your measurements.

### Accessories

For many of the measurements on burst signals, a TTL transition is required to synchronize the measurement system with the transmitter-under-test. The synchronization signal must occur once per frame. If an external signal is unavailable, the 85902A burst-carrier trigger may be used. Many other accessories are available from Agilent to help you make your measurements.

### Ordering Information

Refer to the next few pages in the catalog for more details about each of the measurement personalities. See pages 241 to 245 for detailed information about the 8590 series spectrum analyzers, all available analyzer options and measurement personalities for other applications.

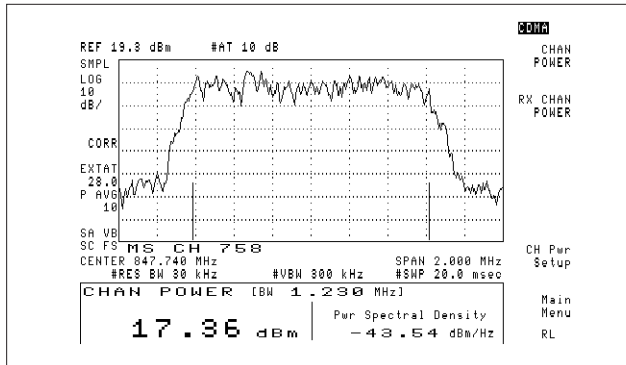

### 85725C CDMA Measurement Personality

Simplify your measurements of cellular, PCS, and other spread spectrum transmitters based on EIA/TIA IS-95, -97, -98 and J-STD-008 standards with the 85725C. Both frequency- and time-domain measurements are provided. The C version of this personality adds the adjacent channel power ratio (ACPR) measurement. The 85725C is designed with a great amount of flexibility, including on-screen help messages, so measurements can easily be configured to meet your special needs.

#### Measurements

##### Frequency Domain

- RF channel power
- Receive RF channel power
- Spurious emissions
- Standby output power (mobile)
- Spectral regrowth
- Occupied bandwidth
- Adjacent channel power ratio (ACPR)

##### Time Domain

- Gated output power
- Gated output power time response
- Time response of open loop power control

##### General Frequency- and Time-Domain Measurements

- Channel spectrum
- Monitor channel
- Monitor band
- Time-domain analysis
- Amplitude probability density
- Mean and peak-to-mean power

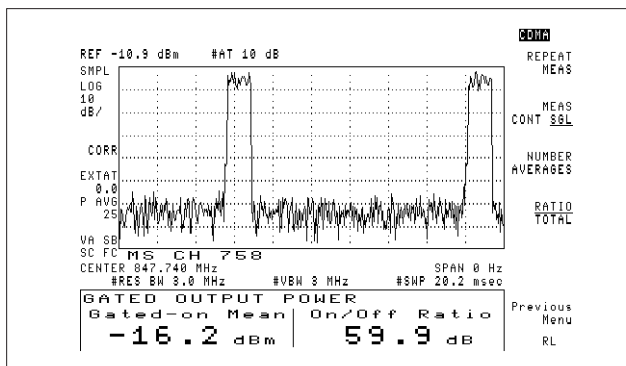

### Built-In Flexibility for PCS and Other Wireless Applications

If you are involved with designs at other frequencies, for other services and even using technologies other than IS-95 or J-STD-008, you will appreciate the greater flexibility we have designed into the CDMA personality. You can configure the personality to make the measurements you need to make.

#### Flexibility Features

- Define your own tuning scheme based on the frequency allocation of your system. The configuration for channel-number tuning has an IS-95A, J-STD-008, ARIB STD-T53, Korean PCS setup and a custom setup.
- Change the pass/fail limit lines from the default settings to meet your requirements. For example, you may want to add test line uncertainty, additional margin, or alternative limits.
- Measure your signal channel power in a channel bandwidth other than the IS-95A and J-STD-008 (for example, AMPS or FCC Part 15). You can easily define the signal measurement bandwidth and viewing span.

### Adjacent Channel Power Ratio (ACPR) Measurement

Easily test Adjacent Channel Power on CDMA components with the new one-button measurement. The flexibility allows the user to make measurements according to the two different Qualcomm definitions, or a faster Agilent-defined method. Integration bandwidths, resolution bandwidths, and frequency offsets can easily be changed in the ACPR setup menu to fit any application.

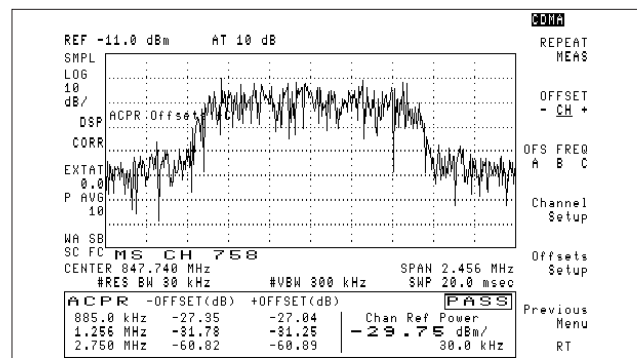

### Recommended Configuration

85725C CDMA Measurements Personality and 8591E, 8594E, 8595E, 8596E, or 8593E Portable Spectrum Analyzer with the following options:

#### With DSP (Opt 151) for high speed measurements

- Opt 004 Precision Frequency Reference
- Opt 053 Improved Amplitude Accuracy for CDMA Cellular Bands
- Opt 151 Digital Signal Processor
- Opt 160 PDC/PHS/NADC/CDMA Firmware for Option 151

#### Without DSP

- Opt 004 Precision Frequency Reference
- Opt 053 Improved Amplitude Accuracy for CDMA Cellular Bands
- Opt 101 Fast Time-Domain Sweeps

### Key Literature

Portable CDMA Spectrum Analyzer, p/n 5963-9969E

85715B  
85722B  
85723A  
85727A  
85722B  
Opt H19  
8590  
E-Series

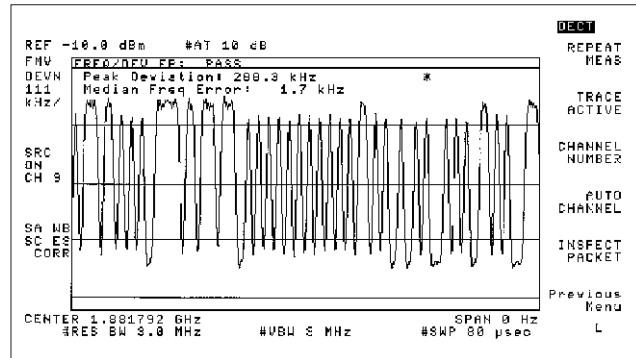
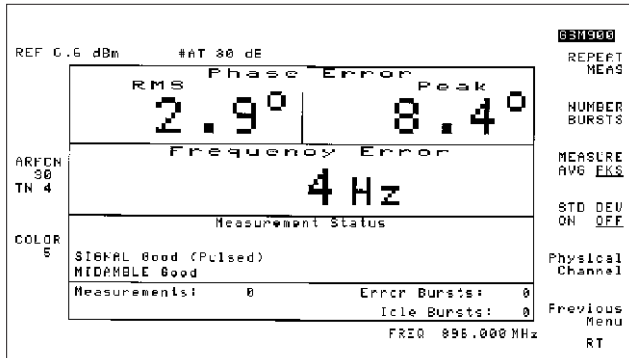

### 85715B GSM900, 85722B DCS1800 and 85727A GSM Multi-Band Transmitter Measurement Personalities

The 85715B, 85722B and 85727A provide all the GSM900 and DCS1800 transmitter measurements specified in the GSM 11.10 (mobile) and GSM 11.21 (base station) recommendations. GSM Phase II specification limits are used and the extended GSM (E-GSM) frequency bands are supported. GSM-based PCS measurements only at 1900 MHz may be made using the 85722B special Option H19.

For next generation GSM systems inter-working between GSM900, DCS1800, and PCS1900, the 85727A measurement personality assures that your new multi-band systems conform to worldwide GSM standards.

### Key Literature

Portable GSM/DCS Transmitter Measurement Systems, Product Overview, p/n 5966-3803E  
GSM900 and DCS1800 Transmitter Testing, White Paper, p/n 5962-9942E

### 85723A DECT Measurement Personality

The 85723A adds the key DECT measurements to the 8590 E-series spectrum analyzers. Option 012 on the spectrum analyzer adds a built-in DECT source which can be used as a stimulus for module testing or sensitivity measurements. The DECT demodulator Option 112 on the analyzer gives the capability to demodulate and analyze GFSK data in the DECT burst.

### Measurements

- Phase and frequency error
- Demodulated data bit display
- Mean transmitted carrier power
- Power versus time
- Output RF spectrum
- Spurious emissions
- Intermodulation attenuation
- Combiner tuning

### Measurements

- Carrier power
- Power versus time
- Center frequency
- Frequency deviation
- Adjacent channel power
- Spurious emissions
- Intermodulation attenuation

### Recommended Configuration

85715B GSM900 Transmitter Measurements Personality  
or  
85722B DCS1800 Transmitter Measurements Personality  
or  
85722B H19 PCS1900 Transmitter Measurements Personality  
or  
85727A GSM Multi-band Measurements Personality  
and  
8594E, 8595E, 8596E, or 8593E Portable Spectrum Analyzer with the following options:

#### With Phase and Frequency Error Measurement

- Opt 004 Precision Frequency Reference
- Opt 105 Time-Gated Spectrum Analysis
- Opt 151 Fast ADC and Digital Demodulator
- Opt 163 GSM/DCS Firmware for Option 151

Or as an ordering convenience, the spectrum analyzer may be ordered with Opt BD1, which contains the 85727A GSM Multi-band measurement personality and the options listed above.

#### Without Phase and Frequency Error Measurement

- Opt 004 Precision Frequency Reference
- Opt 101 Fast Time-Domain Sweeps
- Opt 105 Time-Gated Spectrum Analysis

#### Related Spectrum Analyzer Options

- Opt J62 Enhanced Power Measurement Accuracy in the GSM900 Band (880 to 960 MHz)
- Opt J63 Enhanced Power Measurement Accuracy in the DCS1800 Band (1710 to 1880 MHz)
- Opt J66 Enhanced Power Measurement Accuracy in the PCS1900 Band (1850 to 1990 MHz)

### Recommended Configuration

85723A DECT Measurements Personality and 8594E, 8595E, 8596E, or 8593E Portable Spectrum Analyzer with the following options:

- Opt 004 Precision Frequency Reference
- Opt 012 DECT Source
- Opt 101 Fast Time-Domain Sweeps
- Opt 105 Time-Gated Spectrum Analysis
- Opt 112 DECT Demodulator Card

Or as an ordering convenience, the spectrum analyzer may be ordered with Option E67, which contains the options listed above.

### Key Literature

8590 E-Series DECT Measurement Solutions Technical Data, p/n 5091-7761E



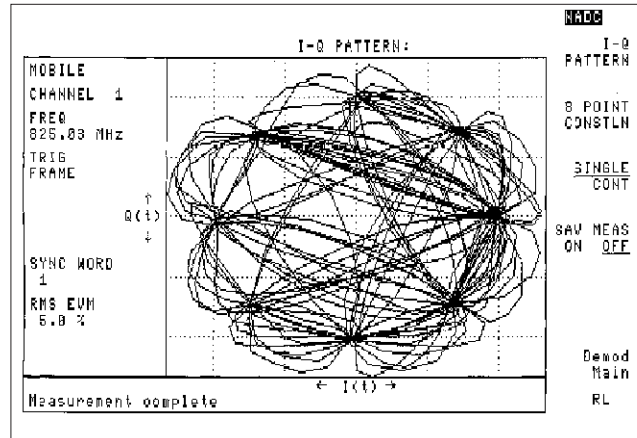
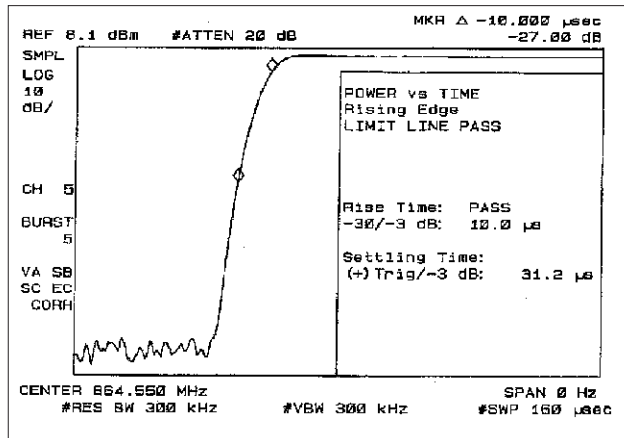

85717A  
85718B

### 85717A CT2-CAI Measurement Personality

The 85717A simplifies I-ETS 300-131 and MPT 1375 RF transmitter testing of second-generation cordless telephones with common air interface (CT2-CAI). All of the required transmitter tests are provided by the personality for both cordless fixed parts (bases) and cordless portable parts (handsets). Added flexibility allows you to define your own custom channel tuning plan and band edge frequencies, as well as set up spurious emissions parameters for your particular needs.

#### Measurements

- Mean carrier power
- Carrier-off power
- Adjacent channel power
- Out-of-band power
- Spurious emissions
- Intermodulation attenuation
- Frequency error and deviation

#### Recommended Configuration

**85717A** Measurements Personality and

**8591E, 8594E, 8595E, 8596E, or 8593E** Portable Spectrum Analyzer with the following options:

- **Opt 004** Precision Frequency Reference
- **Opt 101** Fast Time-Domain Sweeps
- **Opt 105** Time-Gated Spectrum Analysis

For **Frequency Error and Frequency Deviation Measurements** also order:

- **Opt 110** CT2 Demodulator Card
- or
- **53310A** Modulation Domain Analyzer (requires Option 041 GPIB interface on the spectrum analyzer)

For **Improved Amplitude Accuracy in the CT2-CAI Band** Order:

- **Opt 010** Built-In Tracking Generator
- **437B** Power Meter
- **8481A or 8482A** Power Sensor
- **8491A/B Opt 006** 6 dB Fixed Attenuator

#### Ordering Information

More information about the 8590 E-series spectrum analyzers and all analyzer options, including ordering information, can be found on pages 241 to 245.

### 85718B NADC-TDMA Measurement Personality

Based on the complete set of transmitter measurements required by EIA/TIA IS-54-B, -55-A, and -56-A standards, the 85718B provides tests for North American Dual-mode Cellular (NADC) time-division multiple-access radio systems. NADC-based PCS measurements at 1900 MHz (IS-136 standard) can also be made with the 85718B. The push of a button allows you to select between IS-54 800 MHz, IS-136 800 MHz, and IS-136 1900 MHz tuning plans.

#### Measurements

- Carrier power and carrier-off power
- Channel power
- Occupied bandwidth
- Adjacent and alternate channel power leakage
- Attack and release time
- Intermodulation spurious
- Power steps

#### Modulation Accuracy Measurements

- RMS error vector magnitude (EVM) and peak EVM
- RMS magnitude error and phase error
- Carrier frequency error
- Amplitude droop
- I-Q origin offset

#### Recommended Configuration

**85718B** Measurements Personality and

**8594E, 8595E, 8596E, or 8593E** Portable Spectrum Analyzer with the following options:

#### With Modulation Accuracy Measurements

- **Opt 004** Precision Frequency Reference
- **Opt 050** Improved Accuracy for NADC Cellular and PCS Bands
- **Opt 105** Time-Gated Spectrum Analysis (mobiles only)
- **Opt 151** Fast ADC and Digital Demodulator
- **Opt 160** PDC/PHS/NADC/CDMA Firmware for Option 151

#### Without Modulation Accuracy Measurements

- Omit **Opt 151 and 160**
- Add **Opt 101** Fast Time-Domain Sweeps (mobiles only)

Note: In a configuration without modulation accuracy measurements, the 8591E is also supported.

#### Key Literature

Portable NADC-TDMA Transmitter Tester, p/n 5962-6217E

#### Ordering Information

More information about the 8590 E-series spectrum analyzers and all analyzer options, including ordering information, can be found on pages 241 to 245.

85720C  
85726B

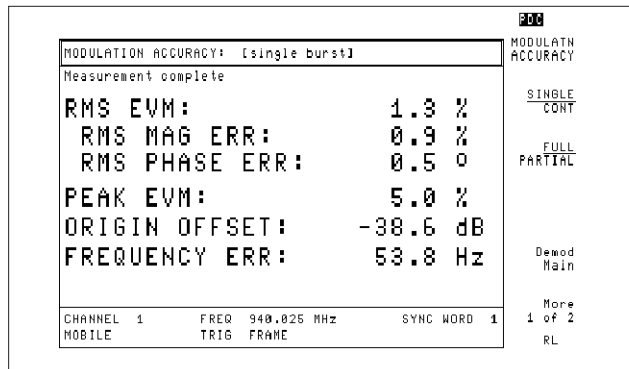

### 85720C PDC Measurement Personality

The 85720C provides transmitter measurements for Personal Digital Cellular (PDC) time-division multiple-access radio systems. This personality provides tests that are customized based on the RCR STD-27C standard for both high and low PDC frequency bands. Also the 85720C test times have been reduced by up to 30 percent as compared to the 85720B.

#### Measurements

- Antenna power
- Carrier-off leakage power
- Channel power
- Occupied bandwidth
- Adjacent channel power leakage
- Burst ramp-up and ramp-down power versus time (PVT)
- Transmitter intermodulation
- Spurious emissions
- Power step

#### Modulation Accuracy Measurements

- RMS error vector magnitude (EVM) and peak EVM
- RMS magnitude error and phase error
- I-Q origin offset
- Carrier frequency error

#### Recommended Configuration

**85720C** PDC Measurements Personality and **8594E, 8595E, 8596E, or 8593E** Portable Spectrum Analyzer with the following options:

##### With Modulation Accuracy Measurements

- Opt 004** Precision Frequency Reference
- Opt 051** Improved Accuracy for PDC Bands
- Opt 105** Time-Gated Spectrum Analysis (mobiles only)
- Opt 151** DSP, Fast ADC, and Digital Demodulator
- Opt 160** PDC/PHS/NADC/CDMA Firmware for Option 151

##### Without Modulation Accuracy Measurements

- Omit **Opt 151 and 160**
- Add **Opt 101** Fast Time-Domain Sweeps (mobiles only)

Note: In a configuration without modulation accuracy measurements, the 8591E is also supported.

#### Key Literature

Portable PDC Transmitter Tester, p/n 5963-9971E

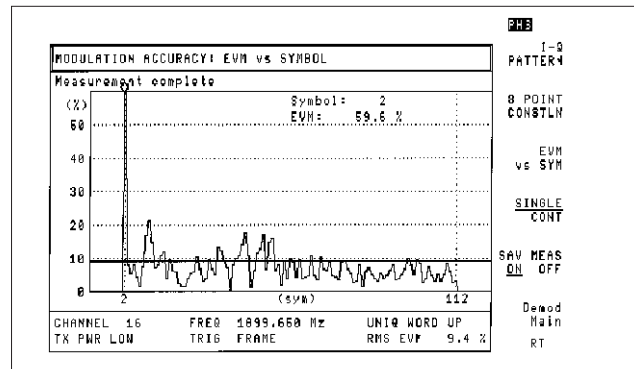

### 85726B PHS Measurement Personality

The 85726B measurement personality provides transmitter tests for Personal Handy Phone System (PHS) radios based on the RCR STD-28 standard. Most tests are also based on the methods of measurement called out by the MKK. In addition to modulation accuracy measurements, this personality has reduced test times by up to 50 percent as compared to the 85726A.

#### Measurements

- Antenna power
- Adjacent channel power
- Burst ramp-up and ramp-down power versus time (PVT)
- Carrier-off time leakage power
- Spurious emission
- Occupied bandwidth

#### Modulation Accuracy Measurements

- RMS error vector magnitude (EVM) and peak EVM
- EVM versus symbol
- RMS magnitude and phase error
- I-Q origin offset
- Carrier frequency error

#### Recommended Configuration

**85726B** PHS Measurements Personality and **8594E, 8595E, 8596E, or 8593E** Portable Spectrum Analyzer with the following options:

##### With Modulation Accuracy Measurements

- Opt 004** Precision Frequency Reference
- Opt 052** Improved Amplitude Accuracy for PHS Band
- Opt 105** Time-Gated Spectrum Analysis
- Opt 151** DSP, Fast ADC, and Digital Demodulator
- Opt 160** PDC/PHS/NADC/DCMA Firmware for Option 151

##### Without Modulation Accuracy Measurements

- Omit **Opt 151 and 160**
- Add **Opt 101** Fast Time-Domain Sweeps

#### Key Literature

Portable PHS Transmitter Tester, p/n 5964-0110E

- Accurate, automated ACP measurements on TDMA and TDD signals
- Measure according to NADC-TDMA, PDC, PHS, and other standards
- Measurement accelerators speed up ACP testing
- Carrier on/off power
- Total channel power, percent occupied bandwidth
- Burst-timing measurements



8561EC

### Accurate and Easy-to-Use Power Measurements Using the 8560EC Series Spectrum Analyzers

Many wireless communications systems today employ burst-carrier techniques such as time division multiple access (TDMA) and time division duplex (TDD) to maximize system capacity. The 8560EC series spectrum analyzers offer power measurements for both continuous and burst signals that are accurate, and easy to make. Measurement capability includes adjacent channel power (ACP), carrier power, channel power, and occupied bandwidth. These analyzers provide the greatest measurement flexibility and RF performance, making them powerful tools for R&D designers working with current wireless standards, or on systems with standards still under development.

#### The 8562EC Spectrum Analyzer

The 8562EC Spectrum Analyzer was designed specifically for digital communications. Its frequency coverage of 13.2 GHz means that now you can use the same analyzer for harmonic and spurious testing both in- and out-of-band. The increased dynamic range and third-order intercept (TOI) capability allows wireless communications engineers to test high-performance components in burst operation systems. See pages 240–244 and 245–246 for details.

#### Measurement Utility Increases Speed and Repeatability

The 85672A Spurious Response Measurements Utility makes measurements fast and easy with the touch of a button. Works on all 8560EC series spectrum analyzers. See page 255 for details.

#### Adjacent Channel Power

The ability to measure ACP on today's wireless telephones, pagers, and other transmitters is critical in R&D, manufacturing and in the field. The 8560EC series spectrum analyzers provide ACP measurements for a variety of wireless communication systems, including support for NADC-TDMA, PDC, and PHS digital formats. Many of the implementation difficulties of the established standards have been addressed, providing fast, accurate, and easy-to-use ACP measurements. Use an 8560EC series spectrum analyzer with the 8563EC Option E35 APCR test set to meet the needs of the emerging W-CDMA specifications.

In addition to the standard analog method for making ACP measurements (used for FM mobile telephones and continuous digital formats), the analyzers support four other methods used for burst-carrier measurements of TDMA and TDD signals:

- Peak (for PDC and PHS)
- Two-bandwidth (for PDC)
- Time-gated (for NADC-TDMA)
- Burst-power (an Agilent proprietary method)

The burst-power method overcomes many of the problems of the other standards, and is suitable for all formats. These methods can easily be adapted to measure other transmitters besides those used for cellular or cordless telephones. Configuration parameters that can be set by the user include channel spacing and bandwidth, number of alternate channels, burst period and width, and values for root-raised-cosine frequency weighting. Measurement results can be displayed in both graphic and tabular formats for ease of data interpretation and documentation. Measurement accelerators are available that give ACP results in just a few seconds, allowing real-time transmitter adjustments.



Setup menu for adjacent channel power measurements

#### Carrier Power

The carrier power feature provides the user with a quick means of measuring the average “on” and “off” power of the burst carrier. This measurement is performed in the time domain, using zero span.

#### Channel Power

The channel power feature quickly provides the user with information on total power within a specified channel bandwidth, as well as power density within the channel. This feature greatly simplifies this common measurement, as the spectrum analyzer automatically performs the necessary integration across the desired frequency band.

#### Occupied Bandwidth

Occupied bandwidth is a way of determining the spectral spread of a signal. It is defined as the bandwidth which contains the specified percent of the total transmitted power. The user may specify the percentage to be anywhere from 0.1 to 99.99 percent.

#### Burst Timing

Complete timing measurements can be made on the burst-carrier signal using digitized, fast time-domain (zero span) sweeps. Using sweep times as fast as 50  $\mu$ s, edge times, burst width, and time between bursts can easily be measured.

#### More Information

More information about the 8560EC series spectrum analyzers, including ordering information, can be found on pages 246–249.

89441A  
89411A  
89450A  
89451A

- 3GPP W-CDMA BTS transmitter test (optional) **NEW**
- Windowed-RC filter and new proprietary ISI compensation technique for EDGE **NEW**
- Unequalled digital modulation troubleshooting tools
- High-accuracy power measurements, including CCDF
- Direct burst-carrier settling analysis
- Uncover DSP-based errors using sophisticated mathematical analysis

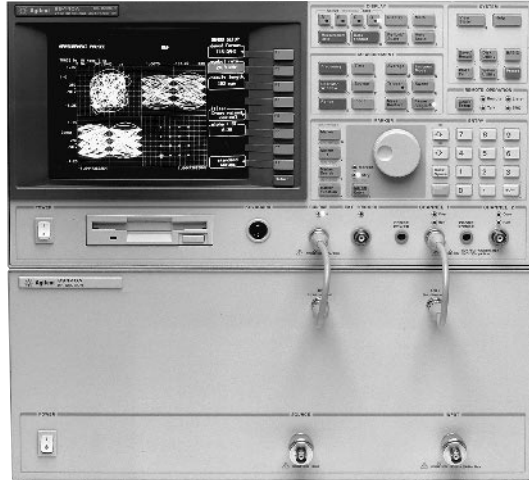

89441A

## Radio Test Personality

The 89451A personality adds “one-button” measurements to quickly set up and test NADC, PDC, PHS, and user-defined systems. Occupied bandwidth, adjacent channel power, modulation accuracy, and frequency tolerance are included in the suite of measurements that can be made on burst or continuous signals. Accuracy required for R&D applications, ease-of-use, and measurement speed are all provided as well as the flexibility to change any of the demodulation parameters or access any of the 89441A measurement modes to troubleshoot difficult system problems.

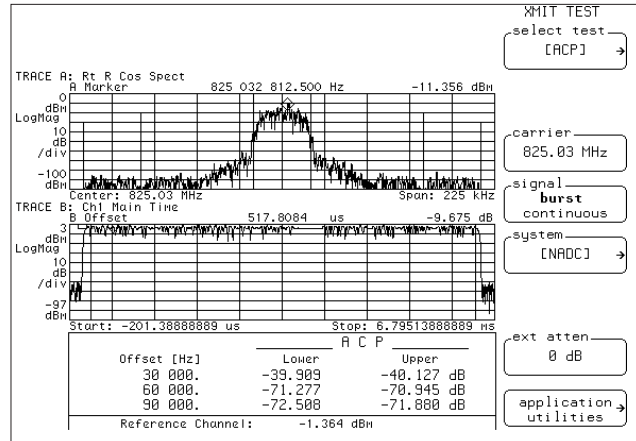

## 89441A DC to 2.65 GHz Vector Signal Analyzer



### A Signal Analyzer for Communications Designers

Designers of communications systems can now spend their time verifying and improving their designs rather than creating specialized testing tools for each component, new signal, or modulation type. Using vector-signal analysis and advanced DSP techniques, signals that formerly required much time and effort to measure can be viewed with ease.

The 89441A offers many types of measurements for characterizing performance or locating problems throughout the block diagrams of transmitters and receivers—from baseband to RF stages. Analyze burst, transient, or modulated signals with simultaneous views of time, frequency, phase, and amplitude. Using this flexibility, measurements such as LO stability, phase noise, and transient characteristics are direct, easy, and reduce the overall amount of required test equipment.

### Adaptive Equalization

Adaptive equalization works with digital demodulation to remove linear errors, such as frequency response and reflections, from transmitted signals. This allows measurements in some impaired channels and can be used to isolate linear vs. non-linear error mechanisms. For more information, see page 263.

### Flexible Vector-Modulation Analysis

Measurements of RF or IF signals are simplified because no external filters, coherent carriers, or symbol-timing signals are required. Baseband I and Q signals can also be analyzed simultaneously with the optional second 10 MHz input channel. Modulation including BPSK, QPSK, offset QPSK, DQPSK,  $\pi/4$ DQPSK, 8PSK, 16-256QAM, VSB, MSK, and 2- to 4-level FSK are supported. Various filter types with adjustable parameters and user-defined filters, in addition to burst length, symbol rate, and carrier frequency can all be selected by the user. To simplify measurements, the parameters for systems such as CDMA, GSM, NADC, PDC, PHS, DECT, Bluetooth, and CDPD can be set with a single button.

Measurement results can be displayed in various formats and tables. Constellation, vector, and eye diagrams provide familiar tools for analyzing vector-modulated signals. Detected data tables display the received binary bits and show results of modulation quality including amplitude droop and quadrature error. The vector-modulation analysis option also offers error measurements by generating an ideal reference signal to compare to the received signal. Results include error vector magnitude, phase error, and magnitude error.

Specialized display from the 89451A Radio Test Personality.

### Support New Generation Modulation Formats

New option 080 covers BTS transmitter tests of 3GPP W-CDMA systems. It provides automatic channel identification of layered codes (7.5 ksym/sec to 960 ksym/sec) with a composite display of all code layers and symbol rates. Capture up to 8 frames of W-CDMA data for post processing analysis in the 3.84 Mchip system. Use either manual or automatic long code selection and isolate single code channels for analysis.

An enhancement to option B7A EDGE Modulation Analysis provides the standard windowed-RC filter. It also includes a proprietary technique that compensates for ISI to provide a clear constellation diagram for troubleshooting. Make a wide range of measurements on both GSM and EDGE bursts. This enhancement is available free to current option B7A owners, as are other recent enhancements. Check the web site for current versions of firmware.

### CAE Simulator Link for Connected Design

Testing “concurrently designed” systems typically requires waiting for an entire system to be physically prototyped and its subsystems assembled. The 89441A analyzer in conjunction with Agilent’s Advanced Design System reduce overall system development time by emulating signals that the hardware will actually generate—but, before the hardware exists. The built-in arbitrary source can provide this emulated signal as stimulus to subsequent sections of the system that have been completed. Also, real-world measurement results can be used in system simulations prior to prototyping. Compatible data formats in Advanced Design System and the 89441A links theory to reality, lowering system development time barriers.

### Solutions for Microwave Frequency Coverage

The 89441A is a complete solution for characterizing systems up to 2.65 GHz. To extend the vector signal analysis capabilities to higher frequencies, the 89410A, 89411A, plus an external spectrum analyzer provide microwave coverage.

See page 262 for more detailed descriptions, specifications, and complete vector signal analyzer ordering information.

For more information, visit our web site:

<http://www.agilent.com/find/89400>



- Includes the most digital formats available in any single source
- Lowest overall cost of ownership
- Easily adaptable to meet changing test requirements
- Bridges the gap between design verification and manufacturing test
- Easy save and recall of instrument states
- Simplified operation for semiskilled workers
- Lightweight and compact

- E4430B
- E4431B
- E4432B
- E4433B
- E4434B
- E4435B
- E4436B
- E4437B

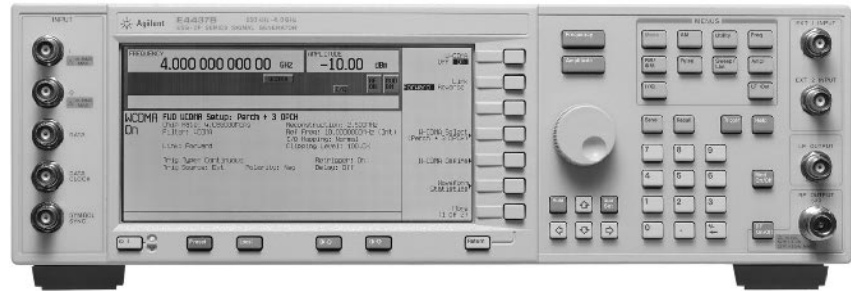

ESG-DP Series E4437B

### Meet Complex Digital Requirements Using the ESG-D and ESG-DP Series of Digital Signal Generators



The ESG-D and ESG-DP series of digital RF signal generators are ideal for testing in a variety of wireless communication applications. Digital receivers or their components can efficiently be tested with the digital modulation capabilities of an ESG-D and DP series signal generators. Test W-CDMA, cdma2000 and CDMA base-station and mobile components by generating single or multiple coded channels. Options provide standard TDMA signals such as EDGE, DECT, GSM, NADC, PDC, PHS, TETRA and the flexibility to create variations of these standards or proprietary modulations. All these digital modulations are easily configured with the use of the table editor feature.

### Option UN8, Real-Time I/Q Baseband Generator

Hardware option UN8 generates fully coded signals, which makes it ideally suited to test receiver and base-station capabilities when actual data is critical. This option simulates mobile or base-station transmissions of common digital communication standards.

Internally generate real-time signals for common standards to test receivers. Change modulation types, data, symbol rate, filter type, and filter factor to generate customized signals for component and system margin testing. Create custom signals by mapping I/Q values and building a unique FIR filter. Easily configure timeslots to simulate different types of traffic, control or synchronization channels (or bursts). Generate mobile or base station transmissions with the internal burst capabilities. Also reduce the need for external equipment with comprehensive data generation capabilities. Option UN8 includes limited Bluetooth capabilities.

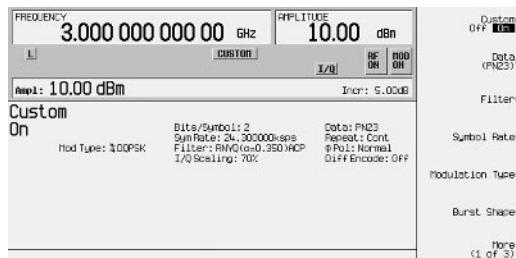

Custom Modulation Editor

Customize modulations or perform margin testing with the I/Q table editor. Achieve maximum flexibility by defining the required modulation in an I/Q table and required filtering with FIR coefficients.

### Option 200, Real-Time 3GPP W-CDMA Personality

Generate a fully coded real-time W-CDMA uplink and downlink signals compliant with the latest revision of the 3GPP standards. By utilizing the real-time I/Q baseband generation of Option UN8 (Rev C or higher) and Option UN9, this firmware option provides fully coded reference measurement channels to perform BERT and base-

band testing on mobile receiver and base-station designs. This complements the existing Option 100, which provides a partially coded multichannel multi-carrier W-CDMA signal used for component test only. Option 200 gives the user the capability to generate custom physical, control, sync, and transport channels while supporting adjustments of the channel parameters. This flexibility combined with the ability to insert data bits at the transport or physical layer is ideal for different stages of testing.

### Option 201, Real-Time cdma2000 Personality

Generate fully coded IS-2000 (SR1) signals for mobile receiver tests. Conduct frame or bit error tests and functional tests of the mobile unit's protocol handling. Firmware Option 201 is backward compatible with IS-95 systems using Radio Configurations 1 or 2. Fully coded channels include pilot, sync, paging, quick paging, fundamental and supplemental traffic channels plus OCNS and QOF. Channels are easily configured using the built-in table editor, with control over power level, FIR filter type, PN offset, Even Second delay, and others, depending upon channel type.

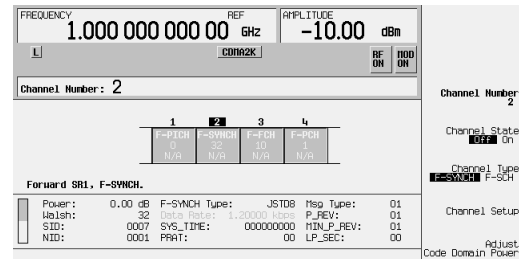

cdma2000 Link Control

### Option 202, Real-Time EDGE Personality

Generate continuous or framed signals. Produce fully coded signals using internally or externally generated data. Firmware option 202 uses  $3\pi/8$ -rotating 8PSK, and "linearized" Gaussian transmit filter. Edit frame data fields and use custom filtering to keep pace with evolving EDGE definition. Synchronize two ESGs to combine EDGE (8PSK) and GSM (GMSK) timeslots. Upload externally defined burst shape waveforms.

### Simulate Common TDMA Standards

DECT, GSM, PDC, PHS, NADC, and TETRA standards are included with option UN8. These standards include easy to configure frames and timeslots. Each timeslot within a frame can be configured independently to simulate different types of traffic, control or synchronization channels (or bursts). Modify the digitally modulated signals by changing filter factor, data, or data rate to fully characterize components and systems.

### More Information

More information about the ESG-D and ESG-DP series signal generators, including ordering information, can be found on pages 205–208 and 331, or visit our web site: <http://www.agilent.com/find/esg>

8903B

- Measures distortion, SINAD, signal-to-noise
- Measures true-rms ac volts, dc volts, frequency
- Low-distortion programmable source
- rms, average, and quasi-peak detection
- Measures distortion, SINAD
- Measures true-rms ac volts, dc volts, frequency
- rms, average, and quasi-peak detection



8903B

## 8903B Audio Analyzer



The 8903B audio analyzer provides unparalleled versatility and performance for audio measurements from 20 Hz to 100 kHz. The 8903B combines the functionality of a low-distortion audio source, high-performance distortion analyzer, frequency counter, ac voltmeter, dc voltmeter, and SINAD meter into one compact package. With microprocessor control of source and analyzer, the 8903B can perform stimulus-response measurements, such as signal-to-noise ratio and swept distortion, automatically, with no additional equipment.

For ease of use, most measurements on the 8903B are made with only one or two keystrokes. It automatically tunes and auto-ranges for maximum accuracy and resolution. For quick identification of input signals, the analyzer counts and displays the input frequency in all ac measurement modes.

### Low-Frequency Applications

The 8903B has many features that make difficult audio measurements easy. These include flexible data display formats, a selectable balanced or unbalanced input, plug-in filters, and automatic notch filter tuning. With the ratio key, you can establish a reference in % or dB and directly make frequency-response and 3 dB bandwidth measurements without computation. A fully balanced analyzer input allows testing of the bridged power amplifiers found in many radios and car stereos, as well as professional balanced audio equipment.

With 2 internal plug-in filter slots and 6 optional filters to choose from, we simplify your audio measurements by providing the filter networks required by international standards. (See the next page for a complete list of filters.) The 8903B uses true-rms detection (for all signals with crest factor 3) for accurate measurement of complex waveforms and noise. Average and quasi-peak detectors are also available. Accurate distortion measurements typically can be made down to less than -90 dB (0.003%) from 20 Hz to 20 kHz.

For receiver testing, the 8903B has a tunable SINAD notch filter. The filter is automatically tuned to the source frequency.

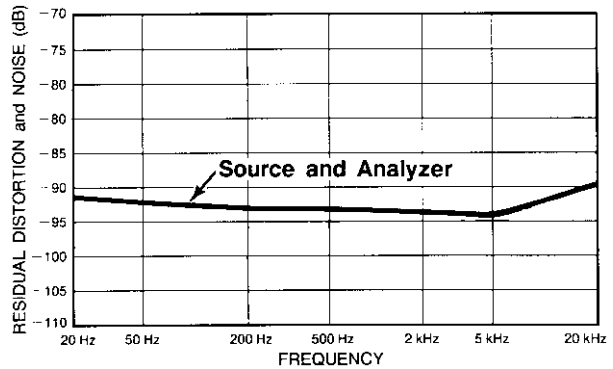

Typical residual THD + noise for source and analyzer combined (source voltage set to 1.5 V, 80 kHz BW).

### System Specifications

#### Distortion

**Residual Distortion and Noise** (the higher of):

- 80 kHz BW: -80 dB (0.01%) or 17  $\mu$ V, 20 Hz to 20 kHz
- 500 kHz BW: -70 dB (0.032%) or 50  $\mu$ V, 20 Hz to 50 kHz; -65 dB (0.056%) or 50  $\mu$ V, 50 kHz to 100 kHz

#### Signal-to-Noise

**Frequency Range:** 50 Hz to 100 kHz

**Display Range:** 0 to 99.99 dB

**Accuracy:**  $\pm 1$  dB

**Input Voltage Range:** 50 mV to 300 V

**Residual Noise** (the higher of): -85 dB or 17  $\mu$ V, 80 kHz BW; -70 dB or 50  $\mu$ V, 500 kHz BW

### Source Specifications

#### Frequency

**Range:** 20 Hz to 100 kHz

**Resolution:** 0.3%

**Accuracy:** 0.3% of setting

#### Output Level

**Range:** 0.6 mV to 6 V open circuit

**Resolution:** 0.3% or better

**Accuracy** (open circuit): 2% of setting 60 mV to 6 V, 20 Hz to 50 kHz; 3% of setting 6 mV to 6 V, 20 Hz to 100 kHz; 5% of setting 0.6 to 6 mV, 20 Hz to 100 kHz

**Flatness** (1 kHz reference):  $\pm 0.7\%$  ( $\pm 0.06$  dB), 20 Hz to 20 kHz;

$\pm 2.5\%$  ( $\pm 0.22$  dB), 20 Hz to 100 kHz

#### Distortion and Noise

- 80 kHz BW: -80 dB (0.01%) or 15  $\mu$ V, 20 Hz to 20 kHz
- 500 kHz BW: -70 dB (0.032%) or 38  $\mu$ V, 20 Hz to 50 kHz; -65 dB (0.056%) or 38  $\mu$ V, 50 to 100 kHz

**Impedance:** 600  $\Omega \pm 1\%$  or 50  $\Omega \pm 2\%$ , front-panel selectable (GPIB programmable)

**Sweep Mode:** Log sweep with up to 500 points per decade or 255 points total between entered start and stop frequencies

### Analyzer Specifications

#### Distortion

**Fundamental Frequency Range:** 20 Hz to 100 kHz  
**Display Range:** 0.001% to 100% (-99.99 to 0 dB)  
**Accuracy:** ±1 dB, 20 Hz to 20 kHz; ±2 dB, 20 kHz to 100 kHz  
**Input Voltage Range:** 50 mV to 300V

#### Residual Distortion and Noise (the higher of):

**80 kHz BW:** -80 dB (0.01%) or 15 µV, 20 Hz to 20 kHz  
**500 kHz BW:** -70 dB (0.032%) or 45 µV, 20 Hz to 50 kHz;  
 -65 dB (0.056%) or 45 µV, 50 kHz to 100 kHz

#### Supplemental Characteristics

**3 dB Measurement Bandwidth:** 10 Hz to 500 kHz  
**Detection:** True-rms or rms-calibrated average

#### SINAD

**Fundamental Frequency Range:** 20 Hz to 100 kHz  
**Display Range:** 0 to 99.99 dB  
**Residual Distortion and Noise:** Same as listed under Distortion  
**Accuracy:** ±1 dB, 20 Hz to 20 kHz; ±2 dB, 20 to 100 kHz  
**Input Voltage Range:** 50 mV to 300 V

#### Supplemental Characteristics

**Detection:** True rms or rms-calibrated average  
**Tuning:** Notch filter is tuned to the internal source frequency.

#### AC Level

**Full Range Display:** 300 V, 30 V, 3 V, 0.3 V, 30 mV, 3 mV, 0.3 mV  
**Overrange:** 33%, except on 300 V range  
**Accuracy:** ±2%, 50 mV to 300 V, 20 Hz to 20 kHz; ±4%, 0.3 to 50 mV,  
 20 Hz to 100 kHz; ±4%, 50 mV to 300 V, 20 to 100 kHz

#### Supplemental Characteristics

**AC Converter:** True-rms responding for signals with crest factor up to 3, rms-calibrated average detection and quasi-peak  
**3 dB Measurement Bandwidth:** >500 kHz

#### DC Level

**Full Range Display:** 300 V, 48 V, 16 V, 4 V  
**Overrange:** 33%, except on 300 V range  
**Accuracy:** ±1.0% of reading, 600 mV to 300 V; ±6 mV,  $V_m$  600 mV

#### Frequency Measurement

**Measurement Range:** 20 Hz to 150 kHz (20 Hz to 100 kHz in distortion and SINAD modes)  
**Resolution:** 5 digits (0.01 Hz for input frequencies <100 Hz)  
**Accuracy:** ±(0.004% + 1 digit)  
**Sensitivity:** 50 mV in distortion and SINAD modes, 5.0 mV in ac level and signal-to-noise

#### Standard Audio Filters

**30 kHz Low-Pass Filter**  
**3 dB Cutoff Frequency:** 30 kHz ±2 kHz  
**Rolloff:** Third-order Butterworth; 18 dB/octave or 60 dB/decade  
**80 kHz Low-Pass Filter**  
**3 dB Cutoff Frequency:** 80 kHz ±4 kHz  
**Rolloff:** Third-order Butterworth; 18 dB/octave or 60 dB/decade

#### Internal Plug-In Filter Options

The 8903B has two internal plug-in filter slots, each of which will accept one of 6 optional filters. The standard 8903B comes with 30 kHz and 80 kHz low-pass filters, but with no plug-in filters. The appropriate filter options must be ordered for the analyzers to have any of the filters listed below. Each filter option has two option numbers: the 010 series for the left filter slot and the 050 series for the right filter slot. Each filter option ordered (maximum of two) adds additional cost to the instrument.

Filters	Option Numbers Filter Position	
	Left slot	Right slot
400 Hz High-Pass	010	050
CCITT Weighting Filter	011	051
CCIR Weighting Filter	012	052
C-MESSAGE Weighting Filter	013	053
CCIR/ARM Weighting Filter	014	054
"A" Weighting Filter	015	055

#### Analyzer Input

**Input Type:** Balanced (full differential)  
**Input Impedance:** 100 kΩ ±1% shunted by <300 pF, each side to ground. (In dc-level mode the input resistance is 101 kΩ ±1%.)  
**Max. Input** (maximum peak input voltage, any combination of ac/dc): 425 V peak, applied differentially or between either input to ground  
**CMRR:** >60 dB, 20 Hz to 1 kHz,  $V_{in}$  <2 V; >45 dB, 20 Hz to 1 kHz; >30 dB, 20 Hz to 20 kHz

#### General

**Temperature:** Operating, 0° C to 55° C; storage, -55° C to 75° C  
**Power:** 100, 120, 220, or 240 V (+5, -10%); 48 to 66 Hz; 100 or 120 V (+5, -10%); 48 to 440 Hz; 100 VA maximum  
**Size:** 146 mm H x 425 mm W x 462 mm D (5.75 in x 16.8 in x 18.2 in)  
**Weight:** Net, 12.3 kg (27 lb); shipping, 16.4 kg (36 lb)

### Ordering Information

#### Analyzer Mainframes

- 8903B Audio Analyzer<sup>1</sup>**
- Opt 001** Input/Output Connectors on Rear Panel Only
  - Opt 010 or 050** 400 Hz High-Pass Filter
  - Opt 011 or 051** CCITT Weighting Filter
  - Opt 012 or 052** CCIR Weighting Filter
  - Opt 013 or 053** C-Message Weighting Filter
  - Opt 014 or 054** CCIR/ARM Weighting Filter
  - Opt 015 or 055** "A" Weighting Filter
  - Opt 907** Front Handle Kit (5061-9689)
  - Opt 908** Rack Flange Kit (5061-9677)
  - Opt 909** Rack Flange Kit (5061-9683) with Front Handles
  - Opt 910** Two sets of Operation/Calibration (08903-90079) and Service Manuals (08903-90062)
  - Opt 915** Service Manual (08903-90062)
  - Opt W30** Extended Repair Service
  - Opt W32** Calibration Service



8903B

7

For more information, visit our web site:

[http://www.tm.agilent.com/tmo/datasheets/English/HP\\_8903B.html](http://www.tm.agilent.com/tmo/datasheets/English/HP_8903B.html)

<sup>1</sup>GPIB cables not included.

Indicates QuickShip availability

E7473A  
E7474A  
E7475A  
E7476A  
E7477A  
E7478A  
N3491A

- Scalable platform for multiple technologies
- Wireless network optimization
- Network performance characterization
- Site selection and evaluation

- Speed network turn-up
- Optimize network performance
- Troubleshooting
- Maximize productivity/minimize cost



E7473A with Options 120 and 330.

## Integrated RF and Call Performance Coverage

A critical measure of the quality of a wireless network is the performance of the air interface. Drive testing is critical to maintaining top network performance. To understand how well service is being delivered to subscribers, you must characterize the performance of your network as a function of location.

The primary underlying factor that defines air interface performance is RF coverage. How well are the RF signals being propagated? Are there coverage holes? Is there intra-system interference? Is there external interference from signals outside of the network?

The performance that a subscriber experiences is measured by call-based parameters: dropped calls, blocked calls, poor voice and data quality, and failed terminations. Both call-based and RF parameters must be measured as a function of location to both characterize the performance and understand the underlying cause of performance problems.

The Agilent E74xx family of air interface measurement tools provides a comprehensive and scalable set of drive testing capabilities for wireless networks. All of the systems share the same hardware/software platform, providing greater flexibility to meet your network optimization needs. The systems support multiple technologies.

The systems are fully scalable and allow the addition of up to four phones and four receivers, which reduces drive test time, since multiple measurements can be performed simultaneously. The software automates the data collection process and provides sophisticated alarm capabilities to notify the user of specific network conditions. The user has complete control over which measurements are logged—any or all. The system can also be configured for use with a pen-tablet computer for indoor RF measurements. In addition, a vehicle-mounted display system is offered to address safety concerns while drive testing. Agilent provides a complete, integrated, and scalable network optimization solution that grows as your needs grow.

## CDMA Drive Test Solutions

The E7473A CDMA drive test system provides comprehensive characterization of the RF environment and call-based performance for CDMA networks in the PCS and cellular bands. Integration of RF coverage and service quality measurements delivers a complete solution for CDMA drive testing. The E7473A system combines the Windows 95/98/NT software with CDMA mobile phone(s) and/or Agilent digital RF receivers. Software options provide phone-based, receiver-based, or combined phone- and receiver-based measurements. The receiver options are available for both the cellular and PCS bands. Both indoor measurements and outdoor measurements can be performed using the same test platform.

The receiver-based software interfaces with up to four digital receivers to make measurements as a function of location. Measurements are made independently from the network parameter settings, providing a completely objective view of the pilot signal environment. Using the receiver-based measurement software, the system can:

- Measure the power ( $E_c$ ,  $I_o$ , and  $E_c/I_o$ ) of any pilot signal in IS-95 and J-STD-008 CDMA networks.
- Measure code-domain power for traffic analysis, capacity management, and evaluation of base station health.
- Provide CW and channel power measurements for site evaluation/selection testing and spectrum display capability for diagnosis of RF problems.

The phone-based system interfaces with up to four CDMA mobile phones to characterize network performance parameters such as Frame Erasure Rate (FER), dropped call rates, and blocked call rates. The system displays rake receiver finger activity and pilot measurement information. Layer III messages are displayed in a clear tree-oriented format.



The combined phone- and receiver-based system, with the ability to do both outdoor and indoor measurements, provides a complete characterization of the network.

### 3G Drive Test Solutions



Building upon proven 2G drive test solutions, the scaleable E747x family of drive test products extends to provide drive test tools for both cdma2000 and W-CDMA 3G networks. The E7476A provides solutions for optimizing W-CDMA networks, while the E7477A addresses the needs of cdma2000 networks.

The E7476A W-CDMA drive test system allows you to make the following measurements: primary sync power, secondary sync channel code and power, scrambling code measurements (peak power, peak power relative to I<sub>0</sub>, aggregate power, and delay spread measurements), delta measurements (secondary sync/primary sync code, scrambling code/secondary sync channel, and aggregate power/peak power), and timing measurements (in chips).

The E7477A cdma2000 drive test system supports the following frequency bands: 850MHz, 1800MHz, and 1900MHz using 1XR/T/SR1. Receiver-based measurements include pilot channel measurements: Ec, Ec/I<sub>0</sub>, Aggregate Ec, Aggregate Ec/I<sub>0</sub>, Delay Spread (in chips), and Aggregate-Peak measurements.

Both systems provide automatic software alarm capability to aid you in detecting network problems as they occur. The systems provide a portable and rugged receiver for easy network deployment, spectrum measurements for interference detection and band clearing activities, and CW and channel power measurements for site evaluation applications. Using the scaleable drive test platform allows you to add up to four digital receivers, to support expansion of up to four additional phones when available, and to provide an evolving platform solution as your 3G networks mature.

### GSM Drive Test Solutions

The E7475A GSM drive test system is a scalable and integrated air interface measurement system used to obtain comprehensive RF measurement and call performance data related to location. Depending on the selected hardware options, the system can make measurements on E-GSM900, GSM-R, DCS1800, GSM1900, or dual-band GSM/DCS networks. Receiver-based, phone-based, or combined measurement capabilities are available. The system can be configured for use with a pen-tablet computer for indoor RF measurements where GPS is not available.

The E7475A GSM drive test system combines digital receivers and test mobile phones with Windows 95/98/NT compatible software.

Using the receiver-based measurement software, the E7475A can:

- Measure the power of all the channels in E-GSM900, GSM-R, DCS1800, and GSM1900 networks.
- Decode broadcast channel BSICs
- Measure adjacent channel and co-channel interference
- Make CW and channel power measurements for cell-site evaluation/selection and provides a spectrum analyzer display, which eases general interference management and diagnosis of RF problems.

Using the phone-based measurements software, the E7475A can control up to four test mobile phones to characterize network performance parameters such as RXQUAL, RXLEV, and Frame Erasure Rate (FER). Call performance statistics such as number of dropped calls and number of handovers can be enumerated. Layer III protocol messaging information can be displayed in a clear tree-oriented format.

The receiver- and phone-based measurements can be performed simultaneously, allowing synergy between the measurement devices. Providing both call-based and RF-based measurements allows users to characterize the performance of their networks and understand the underlying causes of performance problems.

### GPRS and Data Drive Test Solutions



The E7478A GPRS drive test system is a scalable and integrated air interface measurement system used to obtain comprehensive call performance data and measurements. Depending on the selected hardware options, the system can make measurements on E-GSM900 and DCS1800 or dual band GSM/DCS networks. The GPRS solution is a phone-based system, which can be easily integrated with the existing suit of GSM software and receiver options

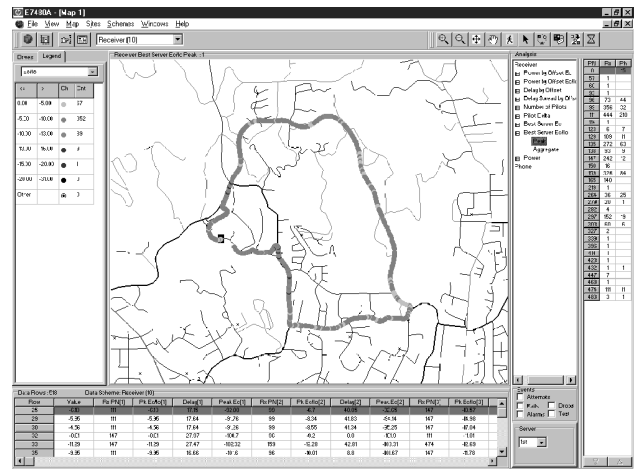

Fast, flexible and easy-to-use post processing.

giving a powerful troubleshooting capability. Measurement capabilities are selected via stackable software licenses that reside on a supplied software protection key. The system can be configured for use with a pen tablet computer for indoor measurements where GPS is not available.

The E7478A GPRS drive test system combines test mobile phones with Windows 95/98/NT compatible software. Extensive event alarm capabilities make it easy to identify problem areas and improve operator efficiency. An "Export Wizard" enables data transfer to post processing applications. Using the phone-based measurement software, the E7478A can control up to four test mobile phones (maximum of four for GPRS only or Data only, and two for simultaneous GPRS / Data) to characterize network performance parameters and call performance statistics such as: serving and neighbor cells, Block Error Rate (BLER), protocol logging, dropped calls, and handovers.

The data measurement drive test software license allows characterization of the air interface performance while transmitting data over the network. It is based on a mobile client(s) and fixed server(s) architecture with user-selectable data sequencing settings. Multiple data transfers can be initiated. Both mobile transmit and mobile receive paths are independently measured with the results being collected and displayed on the mobile client(s).

The data suite will be available from launch for the GPRS drive test solution and then extended to other Agilent Technologies drive test solutions. Please check with your sales representative for an up to date list of supported technologies. Typical data measurement results provided are bit error ratio, minimum, maximum, and average throughput, line errors, and re-transmissions.

### TDMA Drive Test Solutions

The E7474A TDMA drive test system provides comprehensive RF and call-based performance measurements for IS-136, IS-54, and AMPS wireless networks. The system combines Windows 95/98/NT software with Agilent digital RF receivers and/or TDMA mobile phones. Receivers are available for the cellular and PCS frequency bands. The receiver provides the following TDMA measurements:

- Channel analyzer power measurements.
- Adjacent channel interference-power measurements of the upper and lower adjacent channels with respect to the serving channel
- DVCC decoding for IS-136 networks
- CW and channel power measurements for site evaluation/selection
- A spectrum analyzer display for interference detection.

The E7474A software provides automated control of up to four TDMA handsets to characterize network performance parameters such as Bit Error Rate (BER), dropped calls, access failures, receive power, and transmit power. Decoded Layer III messaging information is displayed in an easy-to-read, tree-oriented format. The system can also be configured for use with a pen-tablet computer for RF indoor measurements. The capability of making both call-based and RF measurements allows users to characterize the performance of their networks and understand the underlying causes of performance problems.

E7473A  
E7474A  
E7475A  
E7476A  
E7477A  
E7478A  
N3491A

## Indoor Measurement System NEW

Using the E74xx Option 180 indoor measurement system extends the capabilities of your Agilent drive-test system to characterize CDMA, GSM, GPRS, TDMA, AMPS, W-CDMA, and cdma2000 networks indoors. The indoor measurement system takes the measurements you make with a phone and/or receiver and correlates them with specific locations in a building. The floor plan to be characterized is scanned into the pen-tablet computer. The positions at different points in the building are marked on the floor map using an RF stylus. As you walk around the building, the system displays measurement data on the floor plan at each position marked. Measurements are interpolated in a straight line between waypoints.

All of the phone measurements that are available with the full-featured drive-test systems (including channel, RSSI, and FER), and nearly all of the receiver measurements (including CW power and spectrum analysis) are available for indoor testing. All indoor measurements can be recorded and played back later. The data can also be exported to post-processing tools.

## Multiple Receiver and Multiple Technology Capability

With the receiver-based software license, each drive test system includes one digital RF receiver. Each of the systems allows the integration of up to four digital receivers, all controlled from a single user interface. This provides a powerful solution for characterizing multiple carrier networks, managing networks where more than one technology is present, and also for competitive analysis on a competing network. Measurements using the four receivers can be performed simultaneously. The E747x family of drive test solutions provides a seamless integration for testing multiple technologies (e.g., CDMA, TDMA, GSM, W-CDMA, cdma2000, and GPRS) from a single platform.

## Real-Time Mapping NEW

The real-time mapping software license allows you to plot a single measurement parameter on a map, in a color-coded thematic format, as the data is collected. Base station locations are plotted on the map with site names and sector orientations. Alarms are also plotted on the map. Double clicking on the alarm symbol displays the corresponding alarm text message.

## Vehicle Mounted Display System NEW

The N3419A vehicle-mounted display system improves safety, boosts efficiency, and allows for real-time troubleshooting while using Agilent's wireless network optimization tools. It is a valuable addition to the E747x family of drive test solutions, as well as the E7490A CDMA over-air maintenance tool.

The permanently mounted, easy-to-read display puts key RF parameters in clear view, allowing technicians and engineers to examine network impairments as they happen without taking their eyes off the road. Users can take additional steps and immediately re-drive the trouble area to duplicate the impairment, observing information such as time of day, vehicle traffic conditions, location, and terrain to aid in solving network impairments. The custom keypad enables users to perform essential functions, such as starting and stopping calls, switching between measurement windows, and recording measurements with a single key press. The keypad allows the user to safely troubleshoot RF impairments while driving a vehicle. Note: Availability is subject to local regulations.

## Selected Key Specifications

### Digital Receivers CDMA and TDMA Drive Test Systems

Frequency Range (PCS Band): 1850 to 1910MHz; 1930 to 1990MHz  
 Frequency Range (Cellular Band): 824 to 849MHz; 869 to 894MHz  
 Frequency Range (Japan Cellular Band): 832 to 870 MHz; 887 to 925 MHz  
 Frequency Range (Korea PCS Band): 1710 to 1785 MHz; 1805 to 1880 MHz

### Digital Receivers for GSM Drive Test System

Frequency Range (E-GSM900 Band): 880 to 915 MHz; 925 to 960 MHz  
 Frequency Range (GSM-R Band): 876 to 915 MHz; 921 to 960 MHz  
 Frequency Range (DCS1800 Band): 1710 to 1785 MHz; 1805 to 1880 MHz  
 Frequency Range (GSM1900 Band): 1850 to 1910 MHz; 1930 to 1990 MHz

### Digital Receivers for W-CDMA Drive Test System

Frequency Range (IMT2000 Band): 1920 to 1980 MHz; 2111 to 2170MHz

### Digital Receivers for cdma2000 Drive Test System

Frequency Range (PCS Band): 1850 to 1910MHz; 1930 to 1990MHz  
 Frequency Range (Cellular Band): 824 to 849MHz; 869 to 894MHz  
 Frequency Range (Japan Cellular Band): 832 to 870 MHz; 887 to 925 MHz  
 Frequency Range (Korea PCS Band): 1710 to 1785 MHz; 1805 to 1880 MHz  
 Frequency Range (IMT2000 Band): 1920 to 1980 MHz; 2111 to 2170MHz

## Key Literature

- E7473A Technical Specification, p/n 5968-5555E
- E7473A Configuration Guide, p/n 5968-5553E
- E7473A CDMA Drive Test Application Note, p/n 5968-9916E
- E7474A Technical Specification, p/n 5968-5556E
- E7474A Configuration Guide, p/n 5968-5861E
- E7474A TDMA Drive Test Application Note, p/n 5980-0219E
- E7475A Color Brochure, p/n 5968-5562E
- E7475A Technical Specification, p/n 5968-5564E
- E7475A Configuration Guide, p/n 5968-5563E
- E7475A GSM Drive Test Application Note, p/n 5980-0218E
- E7476A W-CDMA Drive Test System Product Overview, p/n 5980-2132E
- E7477A cdma2000 Drive Test System Product Overview, p/n 5980-2131E
- Indoor Measurement System Product Overview, p/n 5968-8691E
- E7490A CDMA Over-Air Maintenance Tool Product Overview, p/n 5968-8687E
- E7490A CDMA Over-Air Maintenance Tool Technical Specifications, p/n 5968-8687E
- E7490A CDMA Over-Air Maintenance Tool Configuration Guide, p/n 5968-8696E
- N3419A Vehicle Mounted Display System Product Overview, p/n 5980-0721E

## Ordering Information

- E7473A** CDMA Drive Test System
- E7474A** TDMA Drive Test System
- E7475A** GSM Drive Test System
- E7476A** W-CDMA Drive Test System
- E7477A** cdma2000 Drive Test System
- E7490A** CDMA Over-Air Maintenance Tool
- N3419A** Vehicle Mounted Display System

For more information, visit the Drive Test Solutions web site:  
[http://www.agilent.com/find/drive\\_test](http://www.agilent.com/find/drive_test)

- 100 kHz to 1.0 GHz
- POCSAG, FLEX, and FLEX-TD
- Pager testing you can depend on



8648A with Option 1EP

### Easy, Economical, One-Box Pager Testing Using the 8648A Option 1EP



The 8648A Option 1EP provides a complete, economical, one-box pager test solution. It includes the digital pager encoder that supports the popular worldwide standard, POCSAG (Post Office Code Standardization Advisory Group), and the newer paging standards, FLEX and FLEX-TD (RCR-43, for Japan).

### Offering Key FLEX Specifications

The specifications of the 8648A Option 1EP are ideal for the stringent FLEX and FLEX-TD test requirements. It offers 60 Hz frequency shift keying (FSK) deviation accuracy within specific pager service bands. This is the most important FLEX specification. Also, it typically offers 40 Hz carrier frequency accuracy (relative to CW in dcFM).

### Faster, Easier Testing

Now test time is reduced and simplified with the 8648A's semi-automated features:

- Customize your result with user-defined messages of up to 40 characters
- Reduce test time with 5 built-in test messages
- Increase test reliability with 70 internal storage registers capable of storing the entire protocol configuration

### Performance Summary

**Frequency:** 100 kHz to 1 GHz  
**Frequency Accuracy with Option 1E5:** Typically  $0.15 \times 10^{-6}$  x carrier frequency in Hz, or typically  $0.092 \times 10^{-6}$  x carrier frequency in Hz within 90 days of calibration  
**Output Level:** +10 dBm to -136 dBm  
**Output Level Accuracy:** 1 dB (> -127 dBm)  
**Carrier Frequency Accuracy:** (relative to CW in dcFM) 100 Hz (typically 40 Hz), deviation < 10 kHz (within one hour after dcFM calibration)

### Pager Signaling

**Supported Pager Protocols:** POCSAG, FLEX, and FLEX-TD

### POCSAG

**Speed:** 512, 1200, and 2400 bps  
**Message Format:** Tone only, Numeric, Alphanumeric

### FLEX/FLEX-TD

**Speed:** 2 Level FSK: 1600 and 3200 bps; 4 Level FSK: 3200 and 6400 bps  
**Message Format:** Tone only, Numeric (standard and special), Alphanumeric, HEX/binary  
**Address Type:** Short, long (messaging accessible from front panel or GPIB)  
**Message Types:** Five fixed (built-in), one user-defined message  
**Length:** 40 characters maximum  
**Repetition Modes:** Single, burst, continuous (messaging accessible only over GPIB)  
**FLEX/FLEX-TD:** 128 frames  
**POCSAG:** 128 batches  
**Data Rate Accuracy:** 5 ppm

### Key Literature

8648A Pager Test Option, p/n 5964-6686 E

### Ordering Information

**8648A** Synthesized Signal Generator  
**Opt 1EP** Pager Signalling  
**Opt 1E5** High-Stability Timebase (FLEX, FLEX-TD only)  
**FLEX Code Word Generation Software** download from the web



To strengthen our portfolio of solutions for wireless service providers, we recently acquired SAFCO Technologies, a leading provider of software and services for the wireless industry. This acquisition allows Agilent Technologies to provide end-to-end solutions that span network planning and design through installation, operation, and competitive benchmarking of the wireless communications network. Below is a brief description of the solutions that we will now offer as a result of this acquisition. For more detailed information, visit our web site: [www.agilent.com/find/wireless](http://www.agilent.com/find/wireless)

## Network Planning and Design

### CellOpt

Automatic frequency-planning tool helps manage the demands of network capacity while maintaining quality of service:

- Creates implementation-ready plans automatically
- Uses predicted and measured data
- Models multi-layered networks
- Supports advanced network features
- Operates within Internet-ready, client server architecture



The WIZARD software is a versatile, full-featured wireless network planning tool. It is shown here in multiple servers analysis mode, displaying four strongest servers.

### Wizard

Portable wireless network-planning tool to maximize quality of service:

- Full-featured analysis
- Measured data integration
- Runs on Windows 95, 98, and NT
- Laptop-ready software
- Exports to other applications



The Portable VoicePrint FieldPak is a highly-portable in-building survey tool for voice and wireless data networks.

## Network Optimization

### OPAS32

Engineering information management and analysis software to help maximize network profitability:

- Fast identification of problem areas
- Advanced scripting control to generate user-customized, one-button reports
- Compatible with all SAFCO collection systems
- Ability to import data from non-SAFCO sources

## Benchmarking

### VoicePrint and Portable VoicePrint

Multi-technology, wireless benchmarking system for test and evaluation of voice over wireless networks:

- Vehicle or pedestrian benchmarking system
- Benchmarks up to eight networks
- Measures voice quality
- Collects data and provides tools for real-time problem solving
- Less than 5 Kg (11 lb) with battery

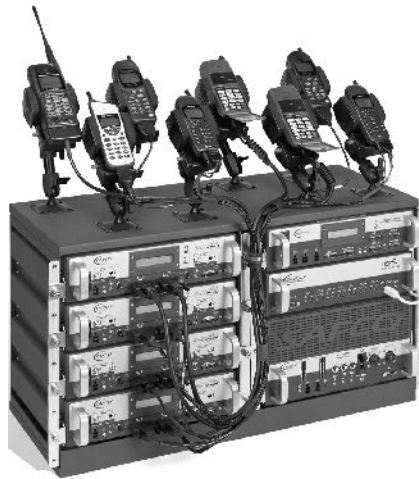

The vehicle-mounted Portable VoicePrint MultiPak benchmarks up to eight voice and wireless data networks simultaneously.

### DataPrint

Multi-technology wireless benchmarking system for test and evaluation of data over wireless networks:

- Vehicle or pedestrian benchmarking system
- Benchmarks 1, 2, or 4 networks simultaneously
- Collects data and provides tools for real-time problem solving
- Measures circuit-switched data quality of service

### RECON

Competitive benchmarking services provide true vision into total network performance:

- Objective network analysis by experienced wireless engineers
- Cost-effective competitive comparisons
- Timely market intelligence and data trending
- Performance measured from the subscriber's perspective
- Available in two formats: written reports and subscription service via the Internet

## Services and Training

- Innovative engineering and technical services help you with network planning, measurement, and analysis
- Technical training classes give your team theoretical and practical insight to effectively engineer your network



**Digital Microwave Radio Test Equipment**

(PN 3708A-5) Testing Satellite Systems with the 3708A  
[5954-9555](#)

**Mobile/Cellular Radio Test Sets**

(PN 892X) Techniques for Programming the 892X Family of Instruments  
[5965-6120E](#)

(PN 83236A/B) Writing Control Software for the 83236A/B  
[5965-5626E](#)

(PN 8920-1) Using the IBASIC Programming Environment on the 8920 Test Set Family  
[5963-0046E](#)

(PN 83204A/5A) CDPD Conceptual Overview  
[5965-6326E](#)

(PN 83204A/5A/21A) CDPD MDBS Cell Site Test Software Troubleshooting  
[5965-7060E](#)

(PN 8921-1) 8921A Cell Site Test Set  
[5962-9475E](#)

(PN 8320NX/8921A) Step by Step Testing Procedure for PCSI CDPD MDBS Radios  
[5965-7345E](#)

(PN 8921-2) 8921A Cell Site Test Set TACS Base Station Testing  
[5962-0157](#)

**Cellular/PCS Transmitter & Receiver Test Equipment**

(PN 89400-1) Frequency and Time-Selective Power Measurements with the 89400 Series Vector Signal Analyzers  
[5091-7194E](#)

(PN 89400-2) Measuring Phase Noise with the 89400 Series Vector Signal Analyzers  
[5091-7193E](#)

(PN 89400-3) CDMA Measurements with the 89400 Series Vector Signal Analyzers  
[5091-7196E](#)

(PN 89400-4) Characterization of Digital Communications Channels with the 89400 Series Vector Signal Analyzers  
[5091-7195E](#)

(PN 89400-5) Measuring Transmitter Transients with the 89400 Series Vector Signal Analyzers  
[5962-9493E](#)

(PN 89400-6) Translated Frequency Measurements with the 89440A  
[5091-7412E](#)

(PN 89400-7) The Dynamic Range Benefits of Large-Scale Dithered Analog-to-Digital Conversion in the 89400 Series VSAs  
[5091-7668E](#)

(PN 89400-8) Using Vector Modulation Analysis in the Integration, Troubleshooting, and Design of Digital RF Communication Systems  
[5091-8687E](#)

(PN 89400-9) Downconverted Measurements Using the 89410A and 89441A  
[5091-8691E](#)

(PN 89400-10) Time-Capture Capabilities of the 89400 Series Vector Signal Analyzers  
[5091-8686E](#)

(PN 89400-11) Phase Noise Performance of the 89400 Series Vector Signal Analyzers  
[5963-0039E](#)

(PN 89400-12) Understanding Time and Frequency Domain Interactions in the 89400 Series Vector Signal Analyzers  
[5962-9217E](#)

(PN 89400-14) Using Error Vector Magnitude Measurements to Analyze and Troubleshoot Vector-Modulated Signals  
[5965-2898E](#)

**Cellular/PCS Spectrum Monitoring & RF Measurement Systems**

E4916A Crystal Impedance Meter  
[5967-6115E](#)

**Pager Test Equipment**

(PN 8648A-1) Pager Testing Using the 8648A with Internal Pager Encoder Option 1EP  
[5965-1131E](#)

(PN 8648A-2) Servicing and Repairing Pagers Using the 8648A Option 1EP  
[5965-1132](#)

## Agilent's web site: Get news, updated product and support information, and more, 24 hours a day.

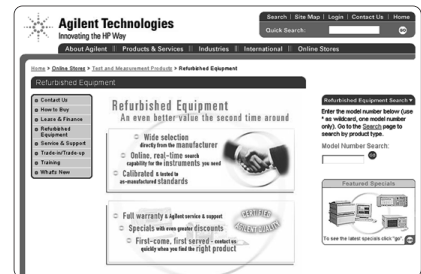
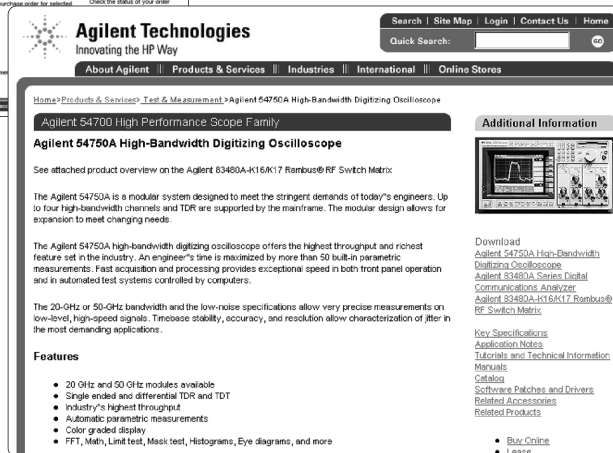

7

### Resources Available Online

- Product and support information more easily with helpful navigation aids and improved web pages that make it easier to access application notes, product overviews, technical details, frequently asked questions, manuals, software, news releases, education course descriptions and schedules, and much more.
- Updated comparison data and evaluation guides/tools that facilitate product selections
- Helpful application notes, downloadable interactive application notes, tutorials, online models, and other learning and problem-solving material
- Quick access to customer support services
- Information on recommended replacements for discontinued products
- Information in your local language\*
- The latest information on the status of your Agilent test and measurement order

### Take Action

- Selected Agilent products—including scopes, logic analyzers, EDA software, multimeters, data acquisition products, signal sources, counters, power supplies, and more\*
- Refurbished instruments\*
- Accessories\*
- Replacement parts\*

For more information on the test and measurement features, resources, and services available on Agilent's web site, see page 3.

Use our online test and measurement resources and services often!  
[www.agilent.com/find/tmc](http://www.agilent.com/find/tmc)

\*Availability of this feature may be limited; an expansion program is ongoing. Online purchases require a credit card.

For best results, view the Agilent web site with Microsoft's Internet Explorer browser.

**Overview** 400

*See also*  
Frequency & Time Standards 504

**Protocol Analyzers** 402

**Digital Transmission Testers** 404

*See also*  
Protocol Analyzers 402

**SONET/SDH Test Sets** 410

**Field Installation & Maintenance** 413

**Voice Testing** 417

**Additional Literature** 418



positive pulse

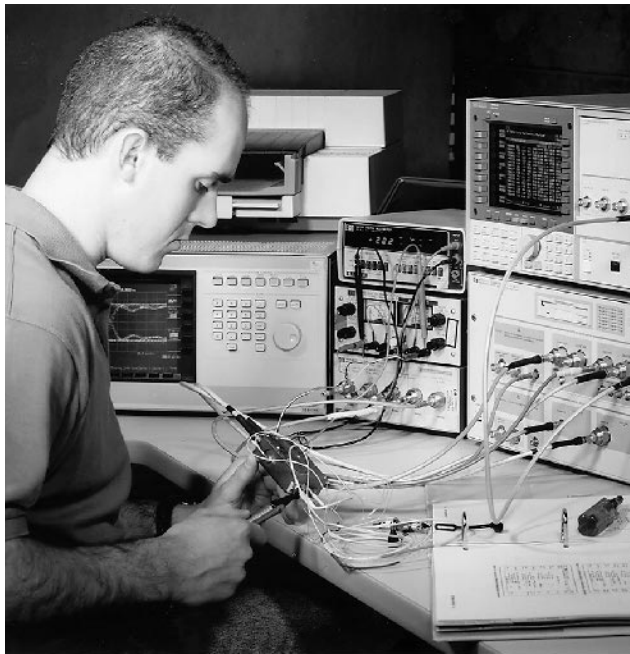

71612B error performance analyzer

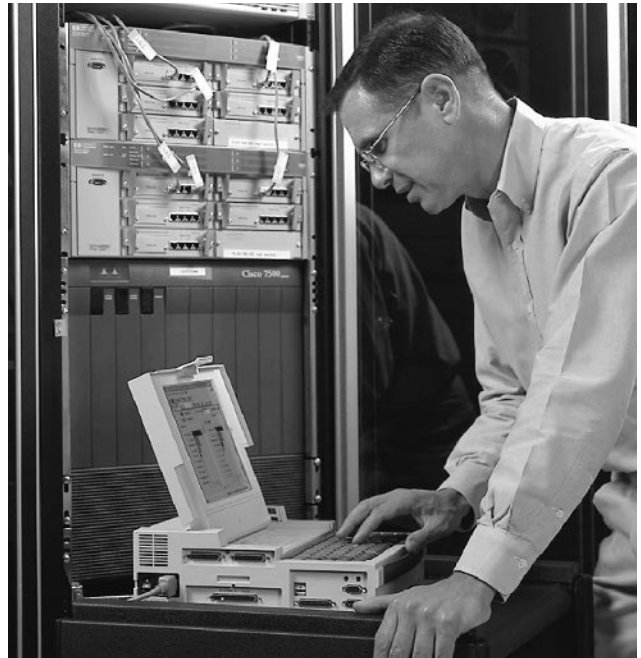

Portable protocol analyzer isolates operational problems on data communications networks.

## Test Solutions for Communications Networks

8

With the most comprehensive technology resources available anywhere, Agilent can provide complete and integrated solutions to meet your test needs at every phase of the network life cycle. Agilent offers telecommunication and data communication test equipment to help you design state of the art, high quality communication products. We also offer the tools you need to test, monitor, troubleshoot and eliminate operational problems on your network, no matter what its size or type.

From handheld testers to network monitoring systems, Agilent equipment is easy to use and rugged enough to stand up to years of use in the field, factory, or lab. Backed by Agilent's unparalleled worldwide support, this total capability enables you to increase your network's quality of service and uptime—and to enjoy a low overall cost of ownership.

You can maximize the value of your investment in Agilent solutions through comprehensive education and training courses, which give your workforce the skills necessary to solve problems accurately and quickly. Both traditional classroom and customized on-site training is available in a wide variety of areas. Example topics include:

- Developing IP Networks in an ATM environment
- Design of SONET Networks
- Frame Relay technology and troubleshooting techniques
- Migrating to fast and switched ethernet

For a complete list of courses and times please visit our web site at: [www.agilent.com/find/tmeducation](http://www.agilent.com/find/tmeducation)

## Protocol Analyzers

Protocol Analyzers are instruments that monitor the traffic on a network to determine that it conforms to the specific set of rules, helps to identify specific error conditions and manages network performance and quality. Agilent provides a broad set of solutions specifically designed for R&D engineers, Network Managers and Field Service Technicians. A full range of technologies is supported, including Ethernet, fast Ethernet, gigabit Ethernet, token-ring, FDDI, ISDN, frame relay, X.25 and ATM. Agilent also supports the industries broadest coverage of network types with solutions for low speed dial-up connection all the way to OC12 core transmission circuits.

## Internet Advisors-LAN/WAN/ATM

The Agilent Internet Advisor gives you the capabilities you need to identify and solve problems correctly the first time you connect, anywhere in the internetwork. To maximize network uptime, the Internet Advisor helps you isolate network problems before they occur. With the capability to base line network behavior, the Internet Advisor provides critical information for intelligently optimizing, reconfiguring, fine-tuning and expanding data communications networks.

## Signaling Test Sets

The Agilent Signaling Advisor is designed for signaling engineers and technicians who maintain, install and develop multilink, multi-protocol, wireline, or wireless signaling networks. This practical, intuitive-to-use test tool enables technicians to deal with routine signaling problems easily, and frees engineers to focus on major or complex signaling issues. Models are available for testing SS7, GSM, and cellular/PCS networks.

## Transmission Impairment Measuring Sets (TIMS)

It is necessary to make analog measurements on a network in order to analyze its ability to transmit signals on the physical layer. The 4934A (TIMS) measures frequency response, noise and cross talk, with the results displayed indicating the health, or acceptability, of the network.

The deployment of DSL technologies such as HDSL and ADSL requires a new generation of wideband TIMS. For example, the N1625A (ANSI) and N1626A (ITU) xDSL TIMS modules plug into the N1610A Service Advisor tablet. The Service Advisor provides a three tier Asymmetric Digital Subscriber Line (ADSL) test solution that supports local-loop service deployment and addresses the testing required for high speed ADSL services for consumers and businesses over existing copper lines.



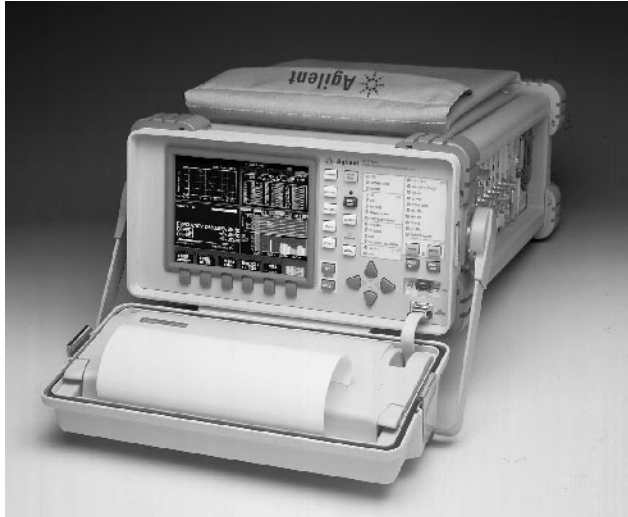

The 37718A and 37719A communications performance analyzers offer a multi-rate test solution for both network operators and network equipment manufacturers.

### Digital Transmission Testers

The fundamental measure of performance, or quality, in digital systems is the probability of any transmitted bit being received in error. This is the purpose of digital pattern generators and error detectors, often referred to as "Bit Error Rate Testers" or BERTs. Agilent offers the highest performance family of these instruments.

#### Parametric

Agilent's complete line of gigabit parametric test solutions helps designers shorten their time to market and improves manufacturing's ramp up to volume. The 86130A 3.6 Gb/s BitAlyzer is a serial BER tester with powerful error analysis and a friendly user interface to make digital testing easy. Ideal for OC-192/STM-64 testing of systems and components, the 71612B error performance analyzer addresses high-speed digital testing up to 12 Gb/s in R&D and manufacturing. The ParBERT 81250 parallel BER tester generates pseudo random word sequences (PRWS) and standard PRBS on parallel lines up to 2.67 Gb/s making it ideal for multiplexer/demultiplexer testing.

#### PDH

Agilent manufactures a full line of products for use in the installation, maintenance, and troubleshooting of telecommunications networks worldwide. These include handheld test sets and portable analyzers. Configurations address your needs for network use and speed, including ATM.

The E7580A ProBER is a powerful handheld solution for testing 2Mb/s and 64 kb/s digital circuits. It offers extensive BER test functions plus a unique range of signal quality measurements (pulse mask, jitter, level, and frequency). For other PDH test solutions see the 4594A T1 Test Advisor and the E8595A HDSL Installer Assistant.

#### SONET/SDH

Agilent's SONET and SDH analyzers perform accurate, reliable tests on network equipment and transmission services. Portable units troubleshoot SONET and SDH equipment at rates up to 2.5 Mb/s. Modular, VXI-based instrumentation can be easily integrated into R&D, production-line, or ATE systems for testing both SONET and SDH standards up to 10 Gb/s.

The Agilent OmniBER family of communications performance analyzers offers a range of one-box, field-portable testers for installation, maintenance, commissioning, and manufacture of transport networks and network equipment. Optical 131 Ohm and 1550 nm interfaces are supported, as well as electrical interfaces at all the commonly used telecom rates. The testers can be configured to include DS<sub>n</sub>, PDH, SDH, SONET, ATM, DWDM, and jitter generation and measurement. They perform non-intrusive monitoring of live traffic or test network protection switching mechanisms, out-of-service BER measurements, and other important parametric tests.

The Agilent SpectralBER test solutions offer flexible and versatile SDH/SONET functional test capability from 155 Mb/s to 10 Gb/s.



Agilent Technologies provides a wide range of portable testers to help you monitor and maintain your digital and analog networks.

### Network Monitoring Systems

Agilent offers distributed systems that monitor network performance and report results at a central location. Achieve accurate fault diagnosis and location quickly, improve network and service reliability, and decrease overall maintenance costs. Agilent offers monitoring systems for:

- Common channel signaling (SS7)
- Interoffice fiber trunks
- Enterprise datacomm networks for LAN, WAN and ATM
- ISP services management
- Network timing and synchronization

For more information on these options, contact the Agilent Call Center in your region.

### Communications Products in Other Catalog Pages

Agilent offers a comprehensive line of network test, measurement, and timing products to satisfy your needs in all types of networks, and all phases of their life cycle.

- Cellular Testers (See pages 352, 353, and 354)
- Microwave Radio Testers (See page 352)

For the latest product information, please visit the Agilent communications test web site: [www.agilent.com/find/comms](http://www.agilent.com/find/comms)

J1955A  
J2300D  
J3446D  
J4630A



## Agilent Advisor

### Complete Solution under One Handle

The Agilent Advisor is designed to be a strategic tool for today's network managers, engineers, and field service personnel for the deployment, troubleshooting, and optimization of today's mission-critical networks. The Advisor gives you the capabilities to connect practically anywhere in the network to help identify and solve performance problems correctly the first time. With the capability to baseline network behavior, the Advisor provides critical information for optimizing, reconfiguring, fine-tuning, and expanding diverse and increasingly complex networks. The Advisor's modular design enables you to start with any combination of LAN, WAN, or ATM test capability, with the option to add further functionality as the network evolves.

This Pentium-based analyzer with Windows architecture offers even new users the ability to get results fast. Several configurations are available for different measurement requirements. The J2300D offers WAN and ATM analysis while the J3446D offers total LAN analysis. The following undercradles and modules are available:

LAN	WAN	ATM	VoIP
10/100 Ethernet	V Series	E1/T1	VQT
Gigabit Ethernet	E1/T1	25Mb	RQM
Token Ring	ISDN BRI/PRI	E3/DS3	
FDDI	HSSI	STM-1/OC-3c	
	E3/DS3 (frame and cell-based)	STM-4c/OC-12c	
	DDS 4-wire		

### Solve Network Problems the First Time

- Expert analysis and network health reporting
- Vitals that anticipate and solve problems
- Commentators point you to the source of the problem
- LAN over WAN analysis
- LAN over ATM analysis
- Customizable statistical analysis
- Extensive on-line help

## Advisor LAN

### Simplifies Troubleshooting with Expert Analysis

The Advisor LAN offers extensive measurement capabilities on Ethernet, Fast Ethernet, Gigabit Ethernet, Token Ring, and FDDI networks. The analyzer has 7-layer protocol decodes, comprehensive statistical measurements, active stimulus/response tests and traffic generation. In addition the Expert Advisor provides continuous feedback on key network issues such as router misconfigurations, connection resets, and many other problems. The drill down capability of the Expert Advisor enables the user to quickly find the source of the problem. On-line help enables the user to understand the problem and get suggestions for solutions or optimizations.

## Advisor WAN

### Eliminates Poor Network Performance

To install, maintain, or troubleshoot a wide area network, you need to test many things: physical errors, equipment interoperability, and network inter-connectivity. The Advisor WAN offers integrated WAN and LAN over WAN performance analysis capabilities, along with bit error rate testing, stimulus and response measurements, and statistical analysis capability to help you solve your networking problems. The Advisor supports Frame Relay, X.25, SNA/SDLC, ISDN, PPP, Async, and ATM DXI.

## Advisor ATM

### Optimize Performance with Real-time QoS Testing and Policing

No matter where you are in the process of bringing up your ATM network, the Advisor ATM gives you the tools to identify and resolve network problems quickly the first time. To install or troubleshoot an ATM link, you need to test for many things: physical congestion, equipment interoperability, ATM cell congestion, and even LAN traffic problems. The Advisor ATM offers integrated ATM, WAN, and LAN performance analysis capabilities you require to get a good look at the physical layer, the data link layer, and the upper layer protocols.

## Advisor Reporter

### Understand Efficient Network Behavior

The Advisor Reporter automatically generates presentation-quality tables, charts and reports on statistics collected on almost any network. Useful for a wide variety of baselining and benchmarking tasks, the Advisor Reporter will help you evaluate network operation, isolate traffic-related problems, evaluate the impact of hardware or software changes, and plan for future growth.

- Build historical trends to anticipate problems and bottlenecks before they occur
- Benchmark applications and network devices
- Cost-justify network equipment upgrades
- AutoReport feature makes report generation as easy as selecting a data file, choosing a report type, and pressing the "Go" Button; AutoReport does the rest
- Internet Reporter's tables are stored in a Microsoft Excel format so that you can perform custom analysis of your network data when you desire

## Commentators

### Agilent VQT Undercradle

The Agilent VQT Undercradle is an objective, end-to-end voice quality test system providing detailed test and analysis capabilities for voice quality on modem telephone networks, including VoIP, VoATM, VoFR, and PSTN. Analog FXO and E&M interfaces connect to the access points of the network to determine the key end-user quality parameters of any voice network: clarity, delay, echo, and others.

For more information visit: [www.agilent.com/comms/onenetworks](http://www.agilent.com/comms/onenetworks)

## Advisor SW Edition

### Intelligent, Quick LAN Troubleshooting

The Agilent Advisor Software Edition (Advisor SW Edition) software gives you the tools you need to isolate and solve network problems on 10/100 Ethernet networks using a standard PC or notebook with Microsoft Windows 98/200/NT operating systems and an appropriate NDIS network interface card. It provides the identical graphical user interface, Expert Advisor, and most of the analysis functionality as the Agilent Advisor LAN/WAN/ATM protocol analysis system. The Advisor SW Edition is a software-based protocol analysis system with the feature set and analysis capability previously only available in hardware-based protocol analysis systems.

## Key Literature

Advisor WAN, Product Overview, p/n 5967-5566E  
Advisor ATM, Product Overview, p/n 5968-1437E  
Advisor LAN, Product Overview, p/n 5980-0990E  
Advisor VQT, Product Overview, p/n 5980-2092E

## Ordering Information

J1955A Advisor SW Edition  
J2300D Advisor WAN  
J3446D Advisor LAN  
J4630A Advisor VQT

## Price

\$4,995  
\$14,995  
\$19,995  
\$19,000

- Intuitive GUI simplifies monitor- and emulate-testing
- Auto-configure hardware and software
- Up to 16 links and 32 duplex timeslots monitor and emulate

J4211A  
J4212A  
J4213A

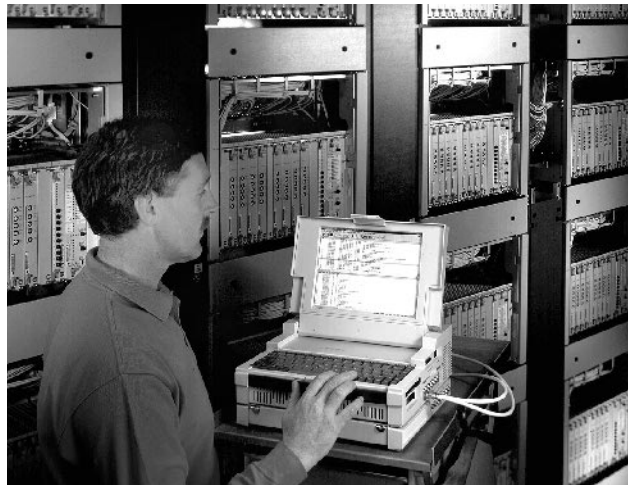

Signaling Advisor

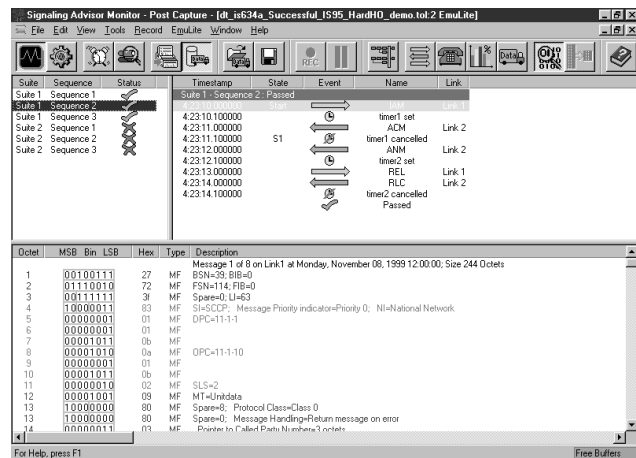

### Signaling Advisor

The Agilent Signaling Advisor is a powerful yet easy-to-use instrument for testing and troubleshooting the complex interactions between network elements in wireless and wireline telecommunications networks.

Designed for use with SS7 and related protocols, the Signaling Advisor helps network operators deploy new revenue-earning services faster by reducing the time taken to develop and execute tests.

### Rolling Out New Services

When deploying new services or modifications to existing services, operators must thoroughly test them offline before installation to verify that they will not introduce problems into the network. The faster operators can perform these tests, the faster they can deploy their new revenue-earning services.

These tests require an instrument that can emulate signaling traffic for prompt-response testing. The Signaling Advisor incorporates Emulite—a new approach to emulation testing. For the first time, it makes emulation testing available to people with no programming experience. Traditional emulation tools require the user to edit individual messages (in Hexadecimal for example), then build them into a sequence using a programming language.

With the Emulite graphical emulation tools, users simply copy previously-captured messages to the Emulite window, then edit the parameters on a field-by-field basis. Tests can be developed in a much shorter time, helping to speed new service roll-out.

### Service Troubleshooting

Once a service has been introduced, it is vital that any problems are quickly solved so that customer satisfaction is not affected. Here the challenge is to isolate and diagnose problems rapidly. The Signaling Advisor helps operators to achieve this by providing a series of user-friendly monitoring tools that make it easy to drill-down into the flow of signaling messages and quickly isolate the relevant ones. These tools include:

- Auto-configure links and protocols—quickly find the signaling traffic
- Graphical Call Trace—spot variations in call patterns at a glance
- Real-time statistics—easily identify performance trends

Emulite graphical emulation tool can be fully integrated with Signaling Advisor's monitor capabilities.

### Integrated Emulation and Monitoring

The Signaling Advisor with Emulite provides a class-leading monitor and emulation package for GSM/GPRS and cellular/PCS wireless applications as well as traditional SS7, AIN and IN testing.

#### J4211A SS7 Signaling Advisor

- ITU-T, ETSI, ANSI and Telcordia SS7 including national and vendor variations.
- AIN and INAP
- ISDN and V.5

#### J4212A GSM/GPRS Signaling Advisor

- GSM - MAP, BSSMAP, BSSAP, Abis, Trau
- GPRS - GTP, BSSGP, BSSAP+, SNDPC, LLC
- Other protocols as per J4211A

#### J4213A cellular/PCS Signaling Advisor

- EIA/TIA 41-D and EIA/TIA 634-A
- Other protocols as per J4211A

### Ordering Information

#### Signaling Advisor

- J4211A SS7 application
- J4212A GSM/GPRS application
- J4213A cellular/PCS application
- 37907A Signaling Advisor mainframe
- E7571A E1 Balanced interface
- E7572A E1 Unbalanced interface
- E7573A T1 interface
- E7574A V.35/RS-232-C/RS-449 interface
- E7575A DS0 interface
- E7577A Link expansion undercradle
- E7578A Fast Ethernet undercradle

ProBER 2

- Combined transmitter and receiver
- 2 Mb/s, n x 64 kb/s and 64 kb/s co-directional testing
- Easy-to-use application driven interface
- Signal quality measurements (pulse mask, level, frequency and 0.172 jitter)
- Local language support
- Over 8 hours battery life



ProBER 2

8

### ProBER 2, 2 Mb/s Handheld Test Set

The ProBER 2 handheld test set provides a powerful handheld solution for testing 2 Mb/s and 64 kb/s digital circuits. It offers extensive BER test functions plus a unique range of signal quality measurements (pulse mask, jitter, level and frequency). This unmatched capability, combined with the intuitive operation of ProBER 2, simplifies installation and maintenance testing for faster problem resolution.

#### Measurement Summary

- Extensive error and alarm generation and measurement
- G.703 Pulse mask measurements
- Jitter measurements to ITU-T O.172
- Frequency and level measurements
- Histogram analysis
- ITU-T recommendations G.821, G.826 and M.2100 performance analysis
- Propagation delay measurement
- VF tone generation and measurement
- Timeslot activity monitor
- Line rate offset
- Frame data control and monitoring
- Channel associated signaling and spare (Sa) bit control
- Synchronization status messages
- Built-in talk/listen
- Thru-mode test capability

#### Key Literature

Brochure, p/n 5967-5869E  
Specifications, p/n 5968-4025E

#### Ordering Information

**E7580A** ProBER 2, 2 Mb/s Handheld Test Set  
**Opt 001** Advanced Signal Quality Measurements  
**Opt 002** 64 kb/s Co-directional Interface  
**Opt 003** M.2100 Analysis  
**Opt 020** Carrying Case  
**Opt AB2** Chinese Localisation



- Solutions optimized for specific application areas—no need to adapt general-purpose instruments
- Scalable platforms help reduce cost-per-test and keep your options open for the future
- Test devices all the way up to OC-768



Digital Transmission Testing

New protocols, relentless speed increases, shrinking error margins—the demands on digital transmission test engineers continue to pile up. Moreover, the task of characterizing, verifying, and testing optoelectronic and optical transmitters, receivers, high-speed digital components, multiplexers, and demultiplexers has grown beyond the capabilities of general-purpose instrumentation.

Thanks to Agilent’s expanded portfolio of bit error ratio (BER) test solutions, you can choose a solution designed for your specific component types and data rates. These test platforms can be configured for your unique test needs today, while preparing you for the future as technology advances.

Use the table below to find the best solution for your test needs.

### BER Test Solutions for Your Unique Needs

#### ParBERT 81250

The new ParBERT 81250 is a modular parallel bit error ratio solution for simultaneously testing up to 64 lines at rates up to 2.67 Gb/s. ParBERT 81250 thoroughly characterizes your device by going beyond BER measurements, providing test features such as propagation delay and setup and hold time. Please turn to page 407 for more information.

#### 86130A BitAlyzer

The new Agilent 86130A BitAlyzer is a 3.6 Gb/s general-purpose BERT with error analysis technology. It lets you quickly locate and analyze the causes behind design problems and manufacturing defects. Easy to set up and operate, the BitAlyzer provides advanced problem-solving capabilities. Please turn to page 406 for more information.

#### SpectralBER

The SpectralBER DWDM test solution offers flexibility and scalability for a variety of manufacturing strategies. It tests optical add/drop multiplexers, optical translators, transponders, and multi-channel systems at OC-3, OC-12, OC-48, and OC-192 speeds.

#### 71612B 12 Gb/s Error Performance Analyzer.

Accurately characterize systems, devices and components with the 71612B error performance analyzer. The 71612B’s wide performance range covers lightwave components and subassemblies, advanced computer technology, and high-capacity communication systems.

#### Complementary Products for Comprehensive Testing

##### 86100A Infiniium DCA-Wide Bandwidth Oscilloscope

With a wide range of plug-in modules supporting measurements up to 50 GHz, the 86100A offers a versatile tool set for demanding digital tests. Use it as an oscilloscope to characterize signal parameters, as a communications analyzer for eye-diagram and pulse measurements of high-speed optical and electrical signals, or as a time-domain reflectometer to test transmission lines. (see page 121 for more information)

##### 71501C Jitter Analysis System

The Agilent 71501C provides advanced jitter analysis of high-speed digital communication waveforms and the components that generate them. The 71501C is frequency agile, performing an extensive range of jitter tests from as low as 50 Mb/s to as high as 12 Gb/s or any rate between. Create a comprehensive jitter solution by pairing the 71501C with the 86130A BitAlyzer or the 71612A 12 Gb/s error performance analyzer.

For more information, please visit our web site:  
[www.agilent.com/find/BERT](http://www.agilent.com/find/BERT)

Application	MUX/deMUX test at OC-768	MUX/deMUX test up to OC-192	BERT solution for satellite communications	Multiple transmitter and receiver tests in manufacturing	FEC and high-speed digital component test	Compliance testing for high-performance transceivers	Characterization of SAN ICs
Agilent BERT solutions	ParBERT 81250	ParBERT 81250	86130A	81250 + SpectralBER	ParBERT 81250	86130A or 71612B	81250 + 86130A
	Test 40 Gbit back to back in parallel at rates up to 2.67 Gb/s	Test up to OC-48 without a golden device	Take advantage of flexible bit rates, transmission formats, and configuration	Dramatically reduce per-test cost and time parallel design problems by testing parallel or multiple serial in optical or electrical	Test parallel to parallel	Get insight into the time and error domains up to 3.6 or 12 Gbps	Solve physical high-speed for Flat Panel Display Link, Fiber Channel, and the new Infiniband standard
		81250 + 71612B Test OC-192 without a golden device		86130A Test as thoroughly as you need, including jitter analysis	86130A Test serial to serial		
Complimentary products	86100A	86100A	86100A	86100A + 71501C		86100A + 71501C	86100A

E4543A  
E4544A  
71501C  
71612B  
Series  
86130A

- 50 Mb/s to 3.6 Gb/s bit error ratio (BER) measurement (3.0 Gb/s with internal clock)
- Advanced error analysis
- Excellent output waveform
- 10 ns clock/data delay range
- Easy to use

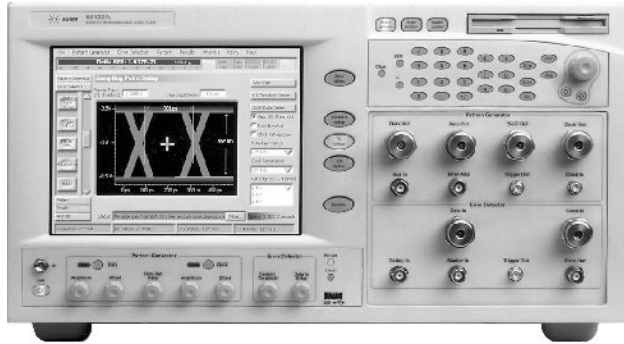

86130A BitAlyzer

### 86130A BitAlyzer

The Agilent 86130A BitAlyzer is an integrated Pattern Generator and Error Detector designed to verify optical and high-speed components or system hardware. Quickly solve design and manufacturing problems with the BitAlyzer's intuitive user interface and built-in patented error analysis from Synthesys Research.

Whether you are testing high-speed digital components or system hardware, you can verify the performance and quality thoroughly. Use industry standard PRBS test patterns from  $2^7-1$  to  $2^{31}-1$  to stress your designs and emulate real-world conditions. Customize your own patterns from the library examples, or create them from the ground up using the flexible on-board pattern editor.

Setup of a BER measurement has never been easier. An intuitive instrument design and knobs for setting signal levels let you control the analyzer from the screen, front panel keys, or (provided) keyboard and mouse. Alternatively, automate your measurements using your favorite software environment and the *plug&play* driver. Remote commands are similar to the BERT, reducing code conversion to a small task.

The 86130A complements the new Agilent Infiniium DCA bringing a new level of insight into your testing toolbox.

### Specifications

<b>Bit Rate</b>	50 Mb/s to 3.6 Gb/s (3.0 Gb/s with internal clock)
<b>Data Output Rise Time (10–90%)</b>	Less than 45 ps, variable crossover
<b>Jitter (pk-pk)</b>	12 ps typical
<b>Clock/Data Delay</b>	Up to 10 ns; resolution 1 ps
<b>Data &amp; Data Bar Outputs</b>	Easy setting ECL, 3.3V PECL, SCFL & user defined.

### Ordering information

- 86130A BitAlyzer**  
3.0 Gb/s BER measurement and analysis with internal clock source  
3.6 Gb/s BER measurement and analysis with external clock source
- Opt 100 2-D error mapping
  - Opt 200 Error correction coding analysis
  - Opt 300 Add 8648D 4.0 GHz external synthesized signal source
  - Opt 0B1 Hard copy programming manuals
  - Opt AX4 Mounting kit for 47.5 cm (19 in) rack, without handles
  - Opt AXE Mounting kit for 47.5 cm (19 in) rack, including front handles

For information on the new Infiniium DCA see page 475.

For more information order the Lightwave Test and Measurement Catalog, see detailed description on page 600.

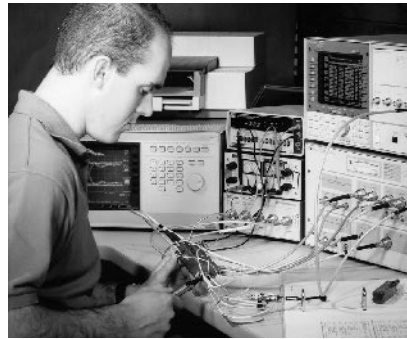

71612B

### 71612B Series 12 Gb/s Testers

The 71612B series of 12 Gb/s products includes an error performance analyzer, pattern generator, error detector, and clock source. Users can program and run variable length test patterns from 1 bit to 8 Mb. This series also offers Error Location Analysis which includes bit BER and error capture. The 71612B Option UHF error performance analyzer and Option UHG pattern generator have four sub-rate pattern outputs at one quarter of the output rate.

### Applications

The increased speed and pattern size allow the simulation of SONET and SDH frames at the STM-64/STS-192 transmission rate and margin testing up to 12 Gb/s. The burst mode feature allows fiber-optic loop tests, while Error Location Analysis allows the identification of pattern dependent errors for user defined patterns.

### Specifications (typical)

- Bit Rate:** 1 to 12 Gb/s (optional 100 Mb/s to 12 Gb/s)
- Patterns:**  $2^7-1$  to  $2^{31}-1$  PRBS, user patterns to 8 Mb
- Transition Times:** (10% to 90%) <30 ps
- Jitter:** <15 ps p-p @ 10 Gb/s
- Data and Data Outputs:** 0.5 V to 2 V p-p amplitude; +1.5 V to -3.0 V range
- Data Input Sensitivity:** <50 mV @ 10 Gb/s (typical)
- Decision Threshold Voltage:** +1 V to -3 V; resolution 1 mV
- Clock/Data Delay:**  $\pm 1$  ns up to 500 MHz; 1 clock period 500 MHz to 12 GHz

### Add Jitter Analysis Capability to the 71612B

Full jitter analysis capability can be achieved with the 71612B with the addition of the 71501C. Measurements include jitter transfer, jitter tolerance and jitter generation over the full data rate range of the error performance analyzer.

### E4543A Q-Factor and Eye-Contour Software

This PC-based software automates measurements made by the 71612B, providing rapid analysis of eye-diagrams in optical line systems. The E4543A software controls the acquisition of measurement data and interprets and displays the eye contour and Q-factor which can be used to estimate very low BER.

### E4544A SONET/SDH Functional Test Software

This PC-based software allows the user to construct SONET/SDH frames up to OC-192/STM-64 and load them into the pattern memory of the 71612B. Frames can be edited to inject specific parity errors and alarm conditions.

### Ordering Information

- 71612B Opt UHF Error Performance Analyzer
- 71612B Opt UHG Pattern Generator
- 71612B Opt UHH Error Detector
- 71612B Opt UKC Delete Clock Source
- 71612B Opt UKJ Error Location Analysis
- E4543A Analysis Software
- E4544A Functional Test Software

Note: Options UHG and UHH can be upgraded to Option UHF with the 15807A Options 001 or 002.

- Generate PRWS and PRBS up to  $2^{31}-1$
- Analyze BER in real-time
- Up to 2.67 Gbit/s
- Up to 120 channels
- Mix of channels and speed classes
- Generate and analyze single-ended, low voltage and differential signals
- Data generation and analysis with sequencing and looping
- Auto synchronization — typically just 100 ms

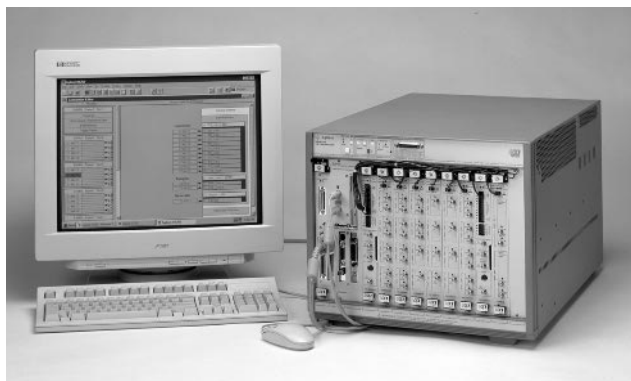

ParBERT 81250

### ParBERT 81250 Parallel Bit Error Ratio Tester NEW

#### Parallel Test Solution for High-speed Digital Components

The ParBERT 81250 provides the world's fastest parallel BER testing of telecom components, forward error correction devices, and storage area network ICs (including gigabit Ethernet, flat panel display links, Fiber Channel and Infiniband).

The system generates pseudo random word sequences (PRWS), user-defined and standard PRBS up to  $2^{31}-1$  on parallel lines. You can analyze bit error ratios with user-defined data, PRBS/PRWS or mixed data in real-time. This enables fast parallel BER measurements — ideal for testing devices with several channels in parallel e.g., multiplexer/demultiplexer devices. The polynomial  $2^n-1$ , the PRBS/PRWS algorithm and the parallel bus width define PRWS. The bits of the PRBS are assigned to parallel lines and are then multiplexed to form a PRBS.

ParBERT 81250 offers data generation and analysis with sequencing and looping so you can realistically stress your DUT. Sequences can contain memory based (up to 8Mbit) and/or PRBS/PRWS data. The system can generate data packets with header and payload and react on control signals from the DUT.

The system has the ability to analyze the data from the device-under-test with the expected data in real-time. The bit error ratio can be viewed while the measurement is running.

ParBERT 81250 can generate and analyze single-ended, low voltage and differential signals — including true differential, so you can test devices based on logic technologies such as LVDS, ECL and PECL, e.g. flat panel display link chips based on LVDS technology.

The ParBERT 81250's VXI foundation offers exceptional flexibility and scalability. It is possible to mix and match analyzer and generator channels (2-120) and speed classes (333 kHz to 2.67 Gb/s) to create a system that fits your specific application needs. A system comprises front-ends, which determine the speed class and generator/analyzer capabilities, modules into which the front-ends slot, clock module(s), and a 13-slot VXI mainframe.

The Windows NT 4.0 operating system provides a fast familiar user interface.

#### Applications

ParBERT 81250 is part of Agilent's high-speed BERT portfolio, and offers solutions for a wide range of applications including:

- Mux/demux testing up to OC 48 (no need for a golden device)
- Mux/demux testing up to OC 192 without a golden device (in combination with 71612B)
- FEC device testing
- Transmitter/receiver test in manufacturing
- OC 768 Mux/Demux testing
- Characterizing SAN (System Area Network) ICs, e.g., flat panel display links

#### Specifications:

##### Data Generator Front-ends

	E4838A	E4843A	E4864A	E4862A
<b>Maximum frequency</b>	667 MHz	667 MHz	1.33 Gb/s	2.67 Gb/s
<b>Outputs</b>	1, differential output 50Ω	1, differential output 50Ω	1, differential	1, differential
<b>Data format</b>	RZ, R1, NRZ, DNRZ	RZ, R1, NRZ, DNRZ	Clock: duty cycle 50%± 10% typ. Data: NRZ, DNRZ	Clock: duty cycle 50%± 10% typ. Data: NRZ, DNRZ
<b>Transition times</b>	0.5 to 4.5ns (10–90%)	<350ps, 200 stp (20–80%)	90 ps typ. @ ECL, LVDS (20–80%)	90 ps typ. @ ECL, LVDS (20–80%)
<b>Amplitude/resolution</b>	<0.1 to 3.50Vpp/ 10mV	0.30 to 2.50Vpp/ 10mV	0.05to 1.8 Vpp/ 10mV	0.05to 1.8 Vpp/ 10mV

##### Data Analyzer Front-ends

	E4835A	E4865A	E4863A
<b>Maximum sampling rate</b>	667 MSa/s	1.33 GSa/s	2.67 GSa/s
<b>Inputs</b>	2, differential or single-ended (switchable)	1, differential or single-ended	1, differential or single-ended
<b>Impedance</b>	50 Ω (100 Ω differential if termination voltage is switched off)		
<b>Threshold</b>	–2.0 to +4.5 V	–2.0 to +3.0 V	–2.0 to +3.0 V

##### Data Modules

	E4832A 667 MHz Module	E4861A 2.67 Gb/s Module
<b>Front-end slots per module</b>	4	2
<b>Maximum frequency</b>	667 MHz	2.67 Gb/s
<b>Max. Memory depth per channel</b>	2 Mbit	8 Mbit
<b>Segments</b>	User defined patterns and PRBS/PRWS	
<b>PRBS, PRWS</b>	$2^n-1, n=7,9,10,11,15,23,31$	
<b>Pulse width</b>	750ps to [period – 750ps] 2ps resolution	50% period typ. in clock mode
<b>Auto-synchronization</b>	On PRBS or memory based data by: • Bit synchronization with or without automatic phase alignment • Automatic delay alignment around a start sample delay (range: ±10ns)	

##### Clock Module

	E4805B
<b>Frequency range</b>	1kHz to 667 MHz
<b>Resolution</b>	1Hz
<b>Accuracy</b>	±50ppm with internal PLL ref.

#### Key Literature

- 5980-0830E ParBERT 81250 Photocard
- 5968-9188E ParBERT 81250 Product Overview
- 5968-9250E Need to test BER? Agilent BERT portfolio brochure

For more information, see: [www.agilent.com/find/ParBERT](http://www.agilent.com/find/ParBERT)

#### Ordering Information

- E4891A** High-speed bundle with 2 generators and 2 analyzers at 1.33 Gb/s
  - E4892A** Super high-speed bundle with 2 generators and 2 analyzers at 2.67 Gb/s
  - E4893A** Data generator bundle with 8 generators at 677 Mb/s
- For all bundles, the following controller options are available:  
**Opt 012** 2-slot-VXIbus-PC  
**Opt 013** IEEE 1394 PC link to VXI

These bundles comprise a ready-to-go system for operation. Options allow you to expand the system to fit your needs with regard to channels and speed.

For assistance in defining your configuration, please contact your local Agilent Call Center.

# Digital Transmission Testers

408

## Handheld and Portable Service Testing

N16XXA Series  
N17XXA Series

- ADSL, TDR, DS1/0, ATM/SONET, Datacom
- Multi-Platform and hot-swappable test modules



Telecom Toolkit

- ADSL, TIMS, ISDN
- ATM, Frame Relay
- Handhelds and light portable tablets



aurora Handhelds and Light Portables

### Telecom Toolkit

#### N1610A Service Advisor Portable Test Tablet

Modular test platform providing residential access and line qualification for 1st tier field deployment and 2nd/3rd tier support.

- Interchangeable test modules
- Windows CE operating system
- Touch sensitive color VGA screen

#### N1700A Service Advisor Undercradle for the Internet Advisor

Operates with the Internet Advisor to provide a comprehensive solution for physical layer through application layer testing.

- Accepts Service Advisor plug-in modules
- Windows user interface

#### N1625A/N1626A DSL TIMS Test Module

Provides comprehensive subscriber loop testing to 2 MHz

- Line qualification test sequences for DSL installations including ADSL, HDSL, SDSL, IDSL, VF-POTS and Modem
- 36 Individual Tests
- ANSI and ITU-T versions

#### N1627A Time Domain Reflectometer (TDR) Test Module

Metallic cable TDR line qualification testing on any cable network including twisted pair, coaxial, and LAN.

- Balanced (coaxial) and unbalanced cable interfaces
- TDR, crosstalk and return loss measurements
- Auto-fault location, wave-form storage and comparison
- 10 feet to over 20,000 feet range.

#### N1660A Dual DS1/0 Test Module

Provides comprehensive T1, Nx56 kbps and Nx64 kbps fractional T1 test capability.

- Optional signaling software provides channel scan, digit capture and dialing capability for E&M, ground start, loop start trunks
- Pulsemask Option provides pulsemask measurement and comparison with industry standard masks.

#### N1640A/N1645A ATM and SONET/SDH Test Modules

Paired to provide complete SONET, SDH, and PDH ATM Testing at STM-1/0o for 1310 intermediate reach single mode later interface.

- SONET and ATM Testing at 51/155Mbps
- Quality of Service Testing

#### N1690A Datacom Test Module

Verifies RS-232, RS-449, V.35, X.21 and EIA-530 links up to 10Mbps.

- Supports DCE and DTE emulation and MONITOR modes
- Comprehensive ASYNC and SYNC BERT testing
- Optional HSSI testing

For more information about these products and more go to the Telecom Toolkit web site at: <http://www.agilent.com/comms/toolkit>

### aurora Handhelds and Light Portables

#### N1738A auroraPresto

Provides second generation ADSL Testing in a low-cost handheld.

- Remote Golden Modem (ATU-R) emulation and IP Ping
- Modular – accepts up to three plug-in cards
- Upgradeable to add central office modem emulation (ATU-C)
- Supports Alcatel DMT chipset

#### N1739A LT2000

The LT2000 is a transmission impairment measurement set (TIMS) for DSL qualification and troubleshooting of copper line pairs.

- Easy to use: one-touch automatic frequency sweeping measures line noise, level, crosstalk, return loss
- Lightweight, battery powered
- Cost effective, entry level TIMS handheld

#### N1737A auroraJazz

ATM service and equipment testing includes bit error rate, ATM cell stream, QoS and OAM testing at rates up to OC3/STM1.

- Accommodates two interchangeable line interfaces SDH, PDH or SONET transmission, from 1.5 to 155 Mbit/s.
- Performs physical and ATM layer testing
- Practical and effective – lightweight, robust design for field use

#### N1725A/N1726A auroraDuet

Basic Rate and Primary Rate ISDN handheld tester.

- Combined BRI/PRI/T1/E1 Tester
- Simulation of both CO and CPE
- D-Channel monitor and decode
- Automatic test suites for quick line status

#### N1727A/N1728A auroraPlus

Basic Rate ISDN handheld tester.

- Hand held – “Butt” style design
- Combined ISDN and POTS capability
- Fully integrated test interfaces
- Rugged, field upgradeable via serial port and Flash EPROM

#### N1729A auroraSonata

Basic Rate and Primary Rate ISDN and POTS handheld tester for ITU-T

- Simulation and monitoring in all modes
- Comprehensive Physical Layer testing
- Protocol monitoring, trace and analysis

#### N1735A auroraTempo

Physical layer and Frame Relay protocol testing for verifying services over V-series interfaces, T1/E1 circuits and DDS lines.

- Simulation and monitoring at all interfaces (UNI/NNI)
- Emulation of Switch and CPE
- Supports SVC and PVC simultaneously
- Real-time analysis, statistical analysis, and detailed simulation

For more information about these products and more go to the aurora Family web site at: <http://www.agilent.com/comms/aurora>



- T1MS, HDSL



4934A

### More DSL Handhelds and Portables

#### 4934A T1MS

This rugged, portable T1MS test set is easy to use and provides essential level, frequency and noise T1MS measurements to 200 kHz.

- Level/frequency up to 110 kHz (200 kHz option)
- Noise, noise-to-ground, noise-with-tone, signal-to-noise ratio
- Three-level impulse noise, P/AR

#### E8505A HDSL Installer's Assistant

The HDSL Installer's Assistant offers a wide range of capabilities for HDSL circuit installation and maintenance including:

- HDSL plug-in card powering and verification
- Load coil detection
- Cable loss measurement
- T1 BERT

#### HDSL Assistants

The HDSL Assistants used together verify a wide range of HDSL installation and maintenance problems and can be used in conjunction with the E8505A HDSL Installer's Assistant.

- E8509A Central Office Assistant
- E8510A Doubler/Remote Assistant
- E8511A Remote Assistant

For more information about our full line of DSL Solutions visit the Agilent's DSL web site at: <http://www.agilent.com/comms/dsl>

- T1/E1 Testing
- Network Service Equipment



### T1/E1 Test Advisor Family

The T1/E1 Test Advisors provide users with capabilities for simultaneous control of two transmitters and receivers.

- Easy-to-use, Windows-based, context-sensitive help
- Optional Plug-in modules for datacom BER testing
- Supports full and fractional T1 or E1 testing
- 2 Mb/s Test Advisors include G.821 Error Analysis

#### E6325A T1 Test Advisor

Used with a PC. Ideal for "drop-box" applications at customer sites that require long-term monitoring via modem or LAN.

#### E6349A E1 Test Advisor

Used with a PC. Ideal for "drop-box" applications at customer sites that require long-term monitoring via modem or LAN.

#### E4594A/E6323A T1/E1 Test Advisor Undercradles

Provides T1/E1 testing for J2300xx LAN or WAN Internet Advisors.

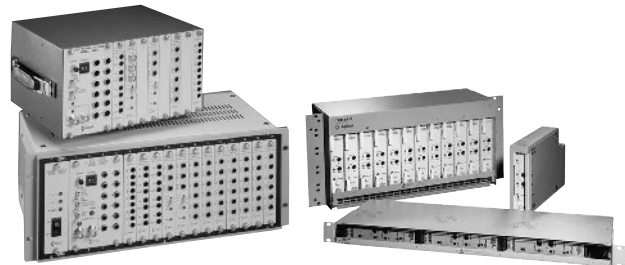

Comms equipment

DS3NIUs

### E4488A, E4489A, E4492A, E8590A Communications Equipment

This family of modular communications products is designed to provide telephone companies and network providers with a cost-effective way to maintain service while installing new T-Carrier and SONET-based network equipment. It consists of compact, standardized, multi-purpose equipment shelves and plug-in modules.

- DS1, DS3, E1 and STS-1 Bridge Amplifiers
- DS3 Bridge Repeater
- DS3 and STS-1/DS3 Signal Sources

#### E4586A, E4587A, E4588A, E4589A DS3 NIUs

This NIU serves as a demarcation point between the network and customer premise equipment featuring loopback capabilities for remote testing and troubleshooting of network or customer problems.

- Resides at the demarcation point between customer and network
- Run BER Tests between the Central Office and NIU

For more information, visit our web sites at:  
<http://www.agilent.com/comms/TestAdvisors> or  
<http://www.agilent.com/comms/networkequipment>

- E44XX Series
- E45XX Series
- E4594A
- 4934A
- E63XXA
- Series
- E85XXA
- Series
- E8505A

# SONET/SDH Test Sets

410

## 10 Gb/s to 155 Mb/s DWDM Test Solution and Remote Test Software

SpectralBER  
E4540A

- Modular and scalable DWDM test solution
- Open and flexible system architecture
- High channel count in a small footprint
- Low cost of test-per-channel

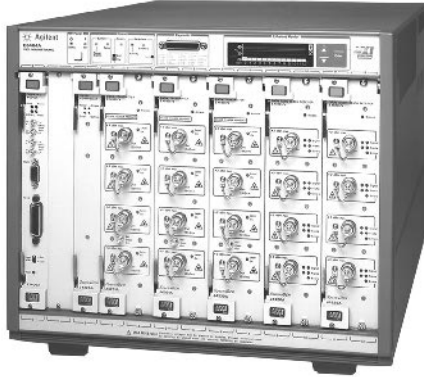

SpectralBER

### SpectralBER Test Solutions

The Agilent SpectralBER family of test solutions offers a flexible and cost-effective approach to testing DWDM, OXC and OADM systems. A range of rates including 10 Gb/s and multi-rate (155/622/2488 Mb/s TX/RX) have been added to the family. Being both modular and expandable, SpectralBER can be tailored to match any production strategy—whether low-volume, high mix or high-volume production. In addition, as optical network elements evolve and channel counts increase, this test solution can be scaled to meet production demand quickly and cost-effectively.

Using the open VXI architecture as its platform, SpectralBER provides high test port density in a small footprint. This allows DWDM systems with high channel counts to be tested simultaneously for faster throughput while avoiding congestion on the production floor. In addition, SpectralBER's open-system approach enables the integration of other test and measurement modules within the same test stand for faster and easier test development. Universal instrument drivers provide additional ease of integration.

Aimed at satisfying the line-final, system-integration and quality-assurance requirements of DWDM, OXC and OADM manufacturers, SpectralBER provides functional test capability for optical add/drop multiplexers, optical translators, transponders, and multi-channel systems. Additional capabilities include BER performance, concatenated payloads to simulate live traffic, and path trace to identify individual channels for continuity tests. SONET/SDH overhead performance monitoring and analysis are also provided, together with error injection and alarm monitoring.

Control of the SpectralBER is via an interactive virtual panel, or instrument driver, or directly via SCPI commands. The system also supports both short- and long-reach optics covering every wavelength on the ITU-T grid.

### Key Features

SpectralBER's quality of service and DWDM features include:

- 1310 nm<sup>1</sup>, 1550 nm or ITU-T<sup>1</sup> wavelengths
- Bit; B1, B2, and J0 byte monitoring and analysis
- Long-reach<sup>1</sup> or short-reach optics for transmitter and receiver
- BER system performance
- Error injection and detection
- Alarm generation<sup>1</sup> and detection
- Manual gating including independent control of individual channels

<sup>1</sup>These features are not available on all models.

### Ordering Information

- SpectralBER 2.5 Gb/s DWDM test solution
- SpectralBER 10 Gb/s DWDM test solution
- SpectralBER Multi-rate DWDM test solution

- Low-cost distributed network analysis software
- Controls the OmniBER and 37XXX range of portable test sets
- Creates a multisite remote monitoring and results retrieval system

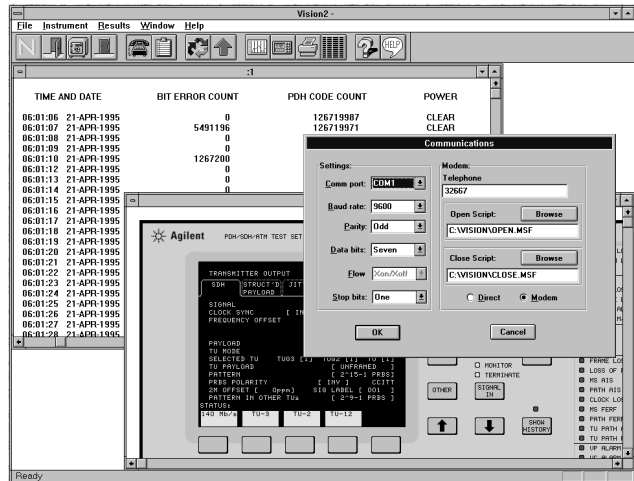

E4540A

### E4540A Distributed Network Analyzer Software

The E4540A allows the creation of a low-cost distributed network analysis system to reliably gather information about network performance from remote test sets. It avoids the large commitment of time and resources needed to implement a dedicated network management system—an important benefit with network technologies changing so rapidly. The E4540A distributed network analyzer software controls Agilent's range of OmniBER and 37XXX test sets, and allows the creation of an extensive measurement and data analysis system. With this PC software it is possible to control one instrument (at a local or remote site) or a number of instruments in a multi-site system.

With network technologies evolving rapidly, it is difficult to keep up to date with ever-changing test procedures. The E4540A interactive diagnostics allow the maximum use of scarce test engineering expertise. The expert at the central control site, using virtual instrument displays, can interactively work with technicians at the remote site. Test sequences simplify complex testing of new technologies. Key E4540A features include:

- No software expertise required to use the E4540A
- Robust automatic results retrieval for monitoring network performance
- Transfer of results into MS Windows applications for analysis, or to produce graphs and reports
- Simplified installation and maintenance testing using stored test sequences and configurations
- Real-time update of keystrokes at remote site and central site

The E4540A analyzer software is Windows-based, operating on a PC or laptop, and connects to the remote site via Hayes compatible modems, or using the LAN remote control port available on the test set.

### Ordering Information

- E4540A Distributed Network Analyzer
- Opt 0A9 10 User License
- Opt UAT Unlimited User License

- Multi-rate testing to OC-48/STM-16, including jitter, ATM and POS
- Supports concatenated payloads to OC-48c/STM-16c
- Comprehensive measurement capability includes protection switching tests, mixed payload generation and analysis, and pointer processing
- SmartTest offers fast access to key measurement tasks
- Works with Agilent's E4540A distributed network analysis software



Portable OmniBER 718 and OmniBER 719 analyzers offer a multi-rate test solution for both network equipment manufacturers and network operators.

### OmniBER 718/719 Communications Performance Analyzer

The OmniBER 718 offers SDH or dual SONET/SDH testing to STM-16/OC-48 including STM-16c/OC-48c payloads. Rugged and portable, this single-unit solution is ideal for installation, maintenance, and manufacturing of SDH and SONET networks and network elements. It provides full PDH/T-carrier capability and SDH/SONET capability, including jitter, ATM, and Packet over SDH/SONET. Plus, it has a large, multi-window color display, optional graphics printer, and integral 3.5 inch disk drive for results storage/retrieval and firmware upgrades.

As a SONET-only version of the OmniBER 718 analyzer, the OmniBER 719 analyzer shares the same measurement attributes, providing multi-rate test capability including jitter, ATM, and Packet over SONET, up to OC-48. The analyzer supports full GR-253 mappings for ANSI payloads.

#### SDH/SONET Capability

The OmniBER 718 provides a single set of multi-rate optical interfaces covering SDH/SONET BER, jitter, ATM, and POS testing at 52 Mb/s, 155 Mb/s, 622 Mb/s, and 2.5 Gb/s. In addition, it provides full ITU-T G.707/GR.253 mapping support including concatenated payloads at STM-1/OC-3c, STM-4c/OC-12c, and STM-16c/OC-48c. Optical 1310 nm and 1550 nm interfaces are supported as well as electrical interfaces at 52 Mb/s and 155 Mb/s. Key measurements supported are SDH/SONET error/alarm generation, APS times, mixed payloads generation/detection, pointer sequence generation, overhead sequence generation and detection. The instrument supports full mux/demux from 2.5 Gb/s to  $n \times 64$  or  $n \times 56$  kb/s. The user interface provides error and alarm stored measurement graphics, pointer graphs, in-service alarm/BIP scan, and out-of-service tributary scan.

The analyzer's SmartTest facility offers fast access to key measurement tasks, while SmartSetup delivers an easy-to-use graphical means of detecting unknown payload structures and aids quick setup of the instrument. This mode also provides fast detection of payload test patterns.

Full thru-mode capability at all synchronous rates (optical and electrical) are provided with internal TU-n/VTn drop/insert for SDH/SONET ring testing.

#### PDH/T-Carrier

PDH interfaces are supported at ITU-T rates of 2, 8, 34, and 140 Mb/s plus T-carrier rates of DS1 and DS3. Full mux/demux is available as is PDH/DSn error/alarm generation and detection.

#### Jitter and Wander

Jitter generation/measurement to ITU-T 0.171/0.172 is available from 2.5 Gb/s through 622/155/52 Mb/s to PDH rates from 140 Mb/s to 2 Mb/s/DS1 (T-carrier rates from DS3/E3 to DS1/E1). Automatic jitter tolerance and automatic narrowband jitter transfer testing is available to ITU-T G.958 for SDH network elements, GR-253 for SONET, and ITU-T G.823 for PDH network elements. Full jitter and wander generation to ITU-T G.825 is available, plus transient pointer jitter measurements to ITU-T G.783/GR.253 and SDH/SONET line rate jitter to ITU-T G.958/GR.253 with RMS and peak-to-peak jitter measurements. Wander generation plus wander measurements at all rates are supported.

The E4547A wander analyzer software provides real-time calculation of the key ITU-T wander performance indices. These are Maximum Time Interval Error (MTIE), Time Deviation (TDEV), and Maximum Relative Time Interval Error (MRTIE). Pass masks are provided to test against current ETSI, ANSI and ITU-T standards.

#### ATM

Both the OmniBER 718 and 719 support channelised ATM payload testing at all rates up to 2.5 Gb/s. Key features include:

- Generation and detection of ATM payloads at all rates up to 2.5 Gb/s
- Jitter testing of ATM payloads at all rates up to 2.5 Gb/s
- Service disruption (APS) measurement of ATM payloads
- ATM tests enabled through SmartTest

#### Packet over SONET/SDH (POS)

Both the OmniBER 718 and 719 support channelized PoS payload testing at all synchronous rates up to 2.5Gb/s. Key features include:

- Generation and detection of POS payloads at all synchronous rates up to 2.5 Gb/s
- Jitter testing on POS payloads at all synchronous rates up to 2.5 Gb/s
- Service disruption measurement of POS payloads
- POS tests enabled through SmartTest

#### Tandem Connection Monitoring (TCM)—SDH only

The OmniBER 718 supports TCM as standard. Key features include:

- Selectable On/Off TCM mode
- Monitoring of N1 byte in High Order Path, monitoring of N1/N2 bytes in Low Order Path
- Easy to use and interpret. TCM functionality means that finger-pointing problems can be identified and resolved quickly

#### Ordering Information

**OmniBER 718 Communications Performance Analyzer**

**37718A** For rates 2.5 Gb/s and below

**Opt 001** SDH test

**Opt 002** SDH/SONET test

**37718B** For rates 622 Mb/s and below

**Opt 001** SDH test

**Opt 002** SDH/SONET test

**37718C** For rates 155 Mb/s and below

**Opt 001** SDH test

**Opt 002** SDH/SONET test

**OmniBER 719 Communications Performance Analyzer**

**E4547A** Wander Analyzer Software

37718A  
37718B  
37718C  
37719A  
E4547A



OmniBER  
720  
OmniBER  
725

- Multi-rate testing to OC-48c/STM-16c, including jitter
- Comprehensive measurement capability includes full overhead access, mapped payloads, and unframed PRBS generation
- SmartTest facility for fast access to key measurement tasks

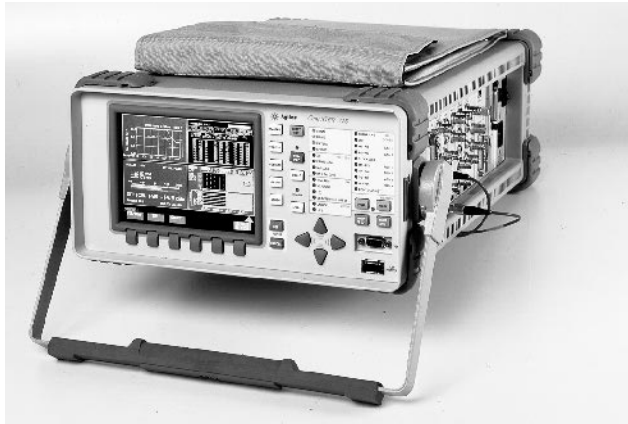

New, portable OmniBER 725 provides optical and differential electrical interfaces for testing fiber optic transmitter (E/O) and receiver (O/E) modules.

## OmniBER 725 Communications Performance Analyzer

NEW

The OmniBER 725 communications performance analyzer offers extensive measurement capability up to 2.5 Gb/s for manufacturers building components and modules for SDH/SONET network equipment. The analyzer provides differential electrical interfaces at all synchronous line rates plus a single set of multi-rate optical interfaces covering SDH/SONET BER and jitter, at 2.5 Gb/s, 622 Mb/s, 155 Mb/s, and 52 Mb/s rates. Optical 1310 nm and 1550 nm interfaces are also supported.

To test the entire signal payload and overhead area with one simple and fast test, the OmniBER 725 allows the SONET/SDH frame structure to be turned off. In this mode, the analyzer can generate a raw PRBS pattern to quickly and accurately characterize the BER and jitter performance of the device under test. In addition, the analyzer provides ITU-T G.707/GR.253 mapping support including concatenated payloads at STM-1/OC-3c, STM-4c/OC-12c, and STM-16c/OC-48c.

Jitter capability to ITU-T 0.171/0.172 is available from 2.5 Gb/s through 622/155/52 Mb/s. Jitter generation and measurement can be performed on both optical and electrical clock signals. Automatic jitter tolerance and automatic narrowband jitter transfer testing is available to ITU-T G.958 for SDH network elements and GR-253 for SONET. Full jitter and wander generation to ITU-T G.825 is supported at all rates, plus SDH/SONET line rate jitter to ITU-T G.958/GR.253 with RMS and peak-to-peak jitter measurements.

### Ordering Information

- OmniBER 725 Communications Performance Analyzer**  
**J1408A** Mainframe with BER test to 2.5 Gb/s  
**J1409A** Mainframe with BER and jitter test to 2.5 Gb/s  
**Opt 001** SDH test  
**Opt 002** Dual SONET/SDH test  
**Opt 003** SONET test  
**Opt 104** 1310 nm optics  
**Opt 105** 1550 nm optics  
**Opt 106** 1310 nm/1550 nm optics

- Low-cost, multi-rate testing to OC-48c/STM-16c
- Measurement capability includes full overhead setup and monitoring, and J0 section trace for DWDM test
- Use with E4540 software for remote troubleshooting and long-term monitoring

## OmniBER 720 Communications Performance Analyzer

NEW

The OmniBER 720 is optimized for BER and DWDM testing of optical tributaries and provides concatenated payload testing at all levels of a SONET/SDH signal. This low-cost analyzer supports a comprehensive set of features including:

- OC-48/12/3/1 rates and/or STM-16c/4c/1c/0c rates
- Bulk payloads from STS-48c/STM-16c, and VT 1.5/TU-11
- Auto-discovery of all received payload channels
- SONET/SDH error and alarm generation/measurement
- SONET/SDH alarm scan
- Full SONET/SDH overhead setup and monitoring, including text decode of:
  - Sync status (S1)
  - APS messages (K1K2)
  - Signal labels (C2 and V5)
- J0 section trace for DWDM test
- J1 and J2 path trace for network path testing
- Optical power and line frequency measurements
- Line frequency offset
- SONET/SDH pointer adjustments to GR-253/ITU-T G.783
- Powerful thru-mode testing for SONET/SDH ring turn-up
- Dual standard configuration (SONET and SDH)

The analyzer's SmartTest facility offers a simple shortcut to key measurement tasks, while SmartSetup delivers an easy-to-use graphical means of detecting unknown payload structures and aids quick setup of the instrument. SmartSetup also provides fast detection of payload test patterns.

The analyzer has the same user interface that's common to all OmniBER analyzers for fast, intuitive operation. It includes a large, multi-window color display, optional graphics printer, and integral 3.5-inch disk drive for results storage/retrieval, and firmware upgrades.

This new low-cost member of the OmniBER family includes a choice of instrument variants for multi-rate testing.

### Ordering Information

- OmniBER 720 Communications Performance Analyzer**  
**Opt 001** SDH test  
**Opt 002** Dual SONET/SDH test  
**Opt 003** SONET test



## Protect Your Networks

Installers and operators of fiber-optic communications networks are faced with the continuing challenge of managing and maintaining their systems with near-perfect uptime and quality while employing the most cost-effective procedures and equipment available. Through the technology and value leadership of our products and services, Agilent Technologies can serve as your working partner in this endeavor. We offer a full range of scalable solutions for fault isolation, characterization, and reporting—on site, at the bench, or remotely across an entire network.

The E6000B Mini-Optical Time Domain Reflectometer (Mini-OTDR) equips the on-site installer or maintenance technician with a complete, highly portable optical fiber test set. This small, lightweight, modular instrument combines high resolution and long distance, high speed and high dynamic range with one-button operation and an award-winning user interface that extends your technicians' efficiency and effectiveness. Several additional modules and sub-modules can enhance their abilities without the penalty of added weight.

At the next level of test and measurement capability, the 8147 Optical Time Domain Reflectometer (OTDR) combines automatic measurement and analysis ability with preprogrammable procedures that speed up operation. Functionality spans on-site problem-solving, bench-top characterization and remote controlling, while modular architecture allows you to expand its capabilities in keeping with both your needs and your budget.

The E6053A, E6058A and the E6060A rack OTDRs are the newest arrivals in the Agilent OTDR family. Primarily suited for use in fiber test systems, the rack OTDRs feature



the high durability of the E6000B Mini-OTDR and easy integration into manufacturing, monitoring or test systems.

To manage and maintain your entire fiber optic network at maximum uptime and quality with minimum cost, implement accessFIBER. Based on a detailed and comprehensive fiber network model, accessFIBER delivers all the information required for effective and efficient network planning, as well as installation and maintenance

processes. Interfaces for standard tools, such as workflow and workforce management systems and GIS (geographic information systems) are provided. The availability of such interfaces means that you can protect your investment and revenues while you add significant value to the quality of service received by your customers.

For further information on accessFIBER, please see our web site:

<http://www.agilent.com/comms/lightwave>

E6053A  
E6058A  
E6060A  
E6091A

- Low cost
- Easy integration into manufacturing, monitoring or test systems
- Software tools included for seamless use with existing systems
- Remote control via PC
- Automatically commission and monitor fiber links



### E6053A, E6058A, E6060A Rack Optical Time Domain Reflectometer

Agilent's new series of Rack OTDRs cost about one-third of the price of the large OTDRs used in most rack systems. They feature the high durability you would expect from an instrument based on the design of the E6000B Mini-OTDR and are ideal for use in the fiber test procedures normally conducted by cable- or network-equipment manufacturers and telecommunications companies.

These Rack OTDRs can be built into a system and controlled remotely with a PC for non-stop use. A range of included software tools is available for integration into existing environments. When used in conjunction with an optical switch and a PC, the rack OTDR can be used for commissioning and monitoring a fiber optic link automatically. The Rack OTDR can also be used with a keyboard and VGA monitor as a standalone Mini-OTDR.

### Specifications

Rack OTDR	Wavelength	Fiber Type	Dynamic Range	Attenuation Deadzone
E6053A	1310/1550 ± 25 nm	Single-mode	35/34 dB	20/25 m
E6058A	1310/1550 ± 25 nm	Single-mode	40/39 dB	20/25 m
E6060A	1625 ± 20 nm	Single-mode	37 dB	28 m

### Key Literature

Optical Network Test, Color Brochure, p/n 5965-1256E  
E6053A, E6058A, E6060A Rack Optical Time Domain Reflectometer, Technical Specifications, p/n 5966-3115E  
User Guide, E6050-91011  
Programming Guide, E4310-91016

For more information, visit our web site:  
<http://www.agilent.com/comms/lightwave>

### Ordering Information

**E6053A** 1310/1550 nm single-mode module  
**Opt 002** Connector interface for straight connectors  
**Opt 006** RS485 serial interface  
**Opt UK6** Commercial calibration certificate  
**E6058A** 1310/1550 nm single-mode module  
**Opt 002** Connector interface for straight connectors  
**Opt 006** RS485 serial interface  
**Opt UK6** Commercial calibration certificate  
**E6060A** 1625 nm single-mode module  
**Opt 002** connector interface for straight connectors  
**Opt 006** RS485 serial interface  
**Opt UK6** Commercial calibration certificate  
**81000AI/FI/GI/HI/KI/SI/VI/WI** Connector Interfaces  
**E6006A** OTDR Toolkit Software  
**E6007A** OTDR Toolkit II Software

- Software toolkit post-processes and analyzes Bellcore GR-196 files



### E6091A OTDR Toolkit II

The E6091A OTDR Toolkit II is ideal for post-processing, analyzing and batch processing Bellcore GR-196 based OTDR files. Systems employing the E6091A software can transfer data serially to a PC running Windows 95, 98 or Windows NT. The data can then be analyzed easily and saved for use in a spreadsheet or database. All OTDR and Mini-OTDR test instruments can be remote-controlled from a PC running the E6091A software.

Other E6091A OTDR Toolkit II features include:

- Analysis of splices, connectors and attenuations
- Comparison of up to four traces simultaneously
- Trace Manager, to enable high-speed multiple trace transfer between the OTDR and PC
- "Print Multiple Traces" capability to facilitate fast paper documentation
- "Process Multiple Traces" capability to allow templating of traces after measurement
- Two-way averaging for accurate loss calculations
- Perform 2-way measurements on multiple traces simultaneously
- Subtract traces for easy trace comparison
- Comprehensive context-sensitive on-line help
- ASCII export for further spreadsheet processing
- "Copy to Clipboard" capability to enable quick and easy report generation

The OTDR Trace Viewer, the viewing companion based on the E6091A which displays Bellcore GR-196 trace data, can be downloaded free from our web site: <http://www.agilent.com/comms/lightwave> (search "OTDR Trace Viewer")

### Key Literature

User Guide, E6090-91013, E6091-91013

For more information, visit our web site:  
<http://www.agilent.com/comms/lightwave>

### Ordering information

**E6006A** OTDR Toolkit Software  
**E6091A** OTDR Toolkit II Software  
**E6091A** OTDR Toolkit II Win 3.1  
**Opt 006** RS485 serial interface  
**Opt UK6** Commercial calibration certificate  
**81000AI/FI/GI/HI/KI/SI/VI/WI** connector interface

- High resolution and dynamic range in each module
- Pre-programmable procedures
- Full on-line analysis and remote operation
- Exceptionally flexible

- Fast and accurate fault characterization
- One button automatic measurement and analysis
- Small, rugged and lightweight
- Excellent resolution
- Ultra high dynamic range

8147  
E6000B



8147

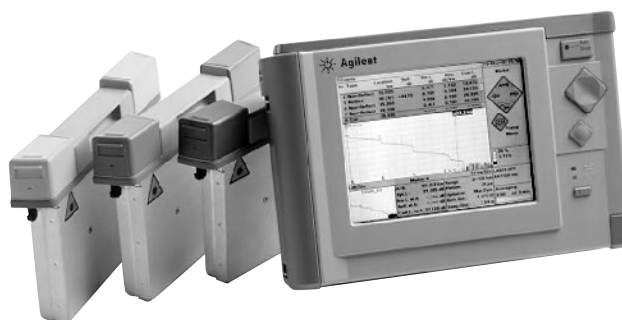

E6000B and modules

### 8147 Optical Time Domain Reflectometer



The 8147 is a high performance optical time domain reflectometer for installation, commissioning and bench applications. It is designed for fast and accurate measurement and analysis of a fiber link, all at the touch of a single button.

“Easy Mode” lets you pre-program complete procedures, so that with a couple of keystrokes, you get standardized measurements. That way, regardless of the operator’s experience level, you get accurate and repeatable results every time.

Extended in-depth analysis including two-way measurements, delta measurements and comparison of up to four traces, is now available online. A return loss graph allows you to see the reflectance of individual events at a glance, as well as the total return loss of the link.

The 8147 remote ability provides the centralized operation, collection and analysis of results from remotely-stationed OTDRs. As a result, you can maximize the use of scarce test expertise throughout your network.

At only 9 kg (20 lbs), the 8147 can be carried easily into those awkward places.

A variety of performance classes can now be selected to ensure you have just the right performance for your application. Many standard interfaces and options are available to ensure that the OTDR can be configured to your exact needs.

### Specifications

8147 OTDR (typ)	Wavelength	Fiber Type	Dynamic Range (typ)	Attenuation Deadzone
E4311A	1310 ± 15 nm	Single-mode	30 dB	10 m
E4312A	1550 ± 15 nm	Single-mode	30 dB	12 m
E4313A	1310/1550 ± 15 nm	Single-mode	30/30 dB	10/12 m
E4314A	1310 ± 15 nm	Single-mode	35 dB	10 m
E4315A	1550 ± 15 nm	Single-mode	34 dB	12 m
E4316A	1310/1550 ± 15 nm	Single-mode	35/34 dB	10/12 m
E4317A	1310 ± 15 nm	Single-mode	40 dB	10 m
E4318A	1550 ± 15 nm	Single-mode	39 dB	12 m
E4319A	1310/1550 ± 15 nm	Single-mode	40/39 dB	10/12 m
E4321A	1625 ± 15 nm	Single-mode	42 dB	14 m
E4324A	1310/1550 ± 15 nm	Single-mode	45/43 dB	10/12 m

### Key Literature

8147 Optical Time Domain Reflectometer, Technical Specifications

p/n 5964-1986E

8147 Optical Time Domain Reflectometer, Configuration Guide

p/n 5964-1987E

User Guide, p/n E4310-91011

Programming Guide, p/n E4310-91016

### Ordering Information

At least one user-exchangeable connector interface (81000xl) is required for the module.

**E4310A** Optical time domain reflectometer mainframe

**Opt 001** DC input: 11–30 V

**Opt 002** Thermal printer

**Opt 003** Color screen, VGA-LCD

**Opt 004** GPiB interface

**Opt 005** LAN interface

**Opt AB2** Chinese user interface

**E4311A** 1310 nm single-mode module (30 dB)

**E4312A** 1550 nm single-mode module (30 dB)

**E4313A** 1310/1550 nm single-mode module (30 dB)

**E4314A** 1310 nm single-mode module (35 dB)

**E4315A** 1550 nm single-mode module (34 dB)

**E4316A** 1310/1550 nm single-mode module (35/34 dB)

**E4317A** 1310 nm single-mode module (40 dB)

**E4318A** 1550 nm single-mode module (39 dB)

**E4319A** 1310/1550 nm single-mode module (40/39 dB)

**E4321A** 1625 nm single-mode module (40 dB)

**E4324A** 1310/1550 nm single-mode module (45/43 dB)

**E6090A** ODTR Toolkit Software

**E6091A** ODTR Toolkit II Software

### E6000B Mini-Optical Time Domain Reflectometer

The E6000B Mini-OTDR maximizes your network uptime by locating and characterizing faults quickly and accurately. The unrivalled combination of 16,000 data points and a minimum sample spacing of 8 cm allows the powerful analysis algorithm to determine the exact location and characteristic of an event. Add to this the 20 m attenuation deadzone, and you really can measure and resolve closely-spaced events along the whole fiber link.

Its one button operation, combined with its intuitive user interface, makes it easy even for those with minimal training to quickly make advanced, reliable OTDR measurements.

Its high dynamic range of up to 45 dB not only gives you the possibility to look at long stretches of fiber, but also helps you increase the speed at which you can accurately determine a certain event.

The E6000B, however, goes beyond a Mini-OTDR. Its fiber break locator mode looks exclusively for breaks, and these are then displayed quickly. The real-time mode gives you instant feedback on parameter changes you make, so that the optimal setup can be found quickly.

### Specifications

E6000B Mini-OTDR	Wavelength	Fiber Type	Dynamic Range	Attenuation Deadzone
E6001A	1310 ± 25 nm	Single-mode	28 dB	10 m
E6002A	1310 ± 25 nm	Single-mode	35 dB	10 m
E6003A	1310/1550 ± 25 nm	Single-mode	35/34 dB	10/12 m
E6003B	1310/1550 ± 25 nm	Single-mode	40/38 dB	10/12 m
E6004A	1310/1550 ± 25 nm	Single-mode	28/28 dB	10/12 m
E6008B	1310/1550 ± 25 nm	Single-mode	45/43 dB	10/12 m
E6010A	1625 ± 20 nm	Single-mode	40 dB	14 m
E6012A	1550/1625 ± 25/10 nm	Single-mode	43/40 dB	12/14 m
E6005A	850/1300 ± 30 nm	Multimode	26/34 dB	10/10 m
E6009A	850/1300 ± 30 nm	Multimode	18/23 dB	10/10 m

### Additional Modules

The E6000B Mini-OTDR is not just a high performance OTDR for single-mode fiber networks. Additional modules and sub-modules enhance its capabilities, without adding any significant weight. The modules simply plug into the existing instrument, making the Mini-OTDR the right tool for versatile, optical fiber test measurements.

#### Multimode Modules

These modules are designed to test all popular multimode fibers at both 850 nm and 1300 nm wavelengths. With an event deadzone of less than three meters, the E6005A multimode module offers a dynamic range of up to 34 dB.

#### Ultra High Performance 1625 nm Modules

The E6010B, E6012A, E4321A and E6060A OTDR modules enable testing of Optical Supervisory Channel capability of WDM links and fast and accurate fiber testing at 1625 nm. Out of band testing also allows users to perform a fiber test while transmitting data at 1310 nm or 1550 nm.

#### E6006A Optical Power Meter Sub-Module

This high performance, miniature and extremely light (130 g) sub-module provides a measurement range of +10 dBm to -70 dBm with 5% accuracy, 0.01 dB resolution and automatic zeroing. The power meter can be used to perform end-to-end loss testing, characterize optical passive components and test transmitter power levels.

A simple user interface and a hold data function make this power meter easy to use. A reference power level can be stored at each wavelength for loss measurements when the source is not available. It can even detect various modulation frequencies used to identify the wavelength being sent by the source. Now it's possible to perform end-to-end loss testing without communicating with the other end of your link.

The power meter has high return loss and low polarization-dependent loss. This ensures accurate measurements, especially for high coherent laser sources, such as in Dense Wavelength Division Multiplexing (D-WDM) and CATV applications. It is fast, providing more than three updates each second. Its non-contact ferrule enhances reliability and facilitates cleaning in the field.

#### E6007A Visual Fault Finder Sub-Module

This visible light source helps you to identify bends, breaks and stress points along individual fibers at the patch panel. The bright red light allows you to locate these faults within the deadzone of an OTDR, and at distances of up to 5 km. The Visual Fault Finder can be used to identify fibers within a cable and also to check the quality of your patchcords and connections. The 1 Hz modulation causes the light to flash, making it easier to identify fibers and locate faults.

### Optical Fiber Test Set—Everything in Your Hands

Agilent's Mini-OTDR provides much more than just the fastest OTDR measurements; all the OTDR modules also act as powerful stabilized continuous wave (CW) light sources, and with the Optical Power Meter Sub-Module in place, you're able to perform loss and power measurements. Within half a minute, you can switch from locating a break with the Visual Fault Finder to checking the multimode LAN.

All the OTDR modules use connector interfaces, which are easy to clean, interchangeable and provide flexibility.

At less than 2.8 kg (6.2 lbs), the E6000B, with its rugged design, is ideal to be carried even into those inaccessible places. Containing the most advanced smart battery technology, you never need be caught without power. The battery delivers exact information on the charge status—with an accurate on-screen "fuel gauge." A full recharge takes less than 3 hours.

There's no need to switch instruments, for multimode or single-mode measurements; with the Mini-OTDR, you have a complete optical fiber test set in one instrument.

### Key Literature

Optical Network Test, Color Brochure, p/n 5965-1256E  
 E6000B Mini-Optical Time Domain Reflectometer, Technical Specifications, p/n 5965-1289E  
 User Guide, E6000-91021  
 Programming Guide, E4310-91016

For more information, visit our web site:  
<http://www.agilent.com/comms/lightwave>

### Ordering Information

At least one user-exchangeable connector interface (81000xI) is required for the module.

#### E6000B Mini-OTDR Mainframe

- Opt 002 Hardcase
- Opt 003 Color Display
- Opt 004 Software Upgrade Kit
- Opt 005 20 MB Flashdisk Card
- Opt 006 B/W Display
- Opt 007 Mini keyboard
- Opt AB0 Traditional Chinese user interface
- Opt AB1 Korean user interface
- Opt AB2 Simplified Chinese user interface
- Opt AB8 Turkish user interface
- Opt AB9 Portuguese user interface
- Opt ABD German user interface
- Opt ABE Spanish user interface
- Opt ABF French user interface
- Opt ABJ Japanese user interface
- Opt ABZ Italian user interface
- Opt ACB Russian-Cyrillic user interface
- Opt AKB Czech user interface

#### E6001A 1310 nm single-mode module (30 dB)

- Opt UK6 Calibration Report

#### E6002A 1310 nm single-mode module (35 dB)

- Opt UK6 Calibration Report

#### E6003A 1310/1550 nm single-mode module (35/34 dB)

- Opt UK6 Calibration Report

#### E6003B 1310/1550 nm single-mode module (40/38 dB)

- Opt UK6 Calibration Report

#### E6004A 1310/1550 nm single-mode module (30/30 dB)

- Opt UK6 Calibration Report

#### E6005A 850/1300 nm multimode module (high performance) (26/34 dB)

- Opt UK6 Calibration Report

#### E6006A Optical Power Meter Sub-Module

- Opt UK6 Calibration Report

#### E6007A Visual Fault Finder Sub-Module

- Opt UK6 Calibration Report

#### E6008B 1310/1550 nm ultra high performance single-mode module (45/43 dB)

- Opt UK6 Calibration Report

#### E6009A 850/1300 nm multimode module (economy) (18/23 dB)

- Opt UK6 Calibration Report

#### E6010A 1625 nm ultra high performance single-mode module (40 dB)

- Opt UK6 Calibration Report

#### E6012A 1550/1625 nm ultra high performance single-mode (43/40 dB)

- Opt UK6 Calibration Report

#### E6090A OTDR Toolkit Software

#### E6091A OTDR Toolkit II Software

#### 81000AI/FI/GI/HI/KI/SI/VI/WI Connector Interfaces





J1981A Voice Quality Tester

## Telegra Voice Quality Tester

### The Comprehensive, Objective Voice Quality Tester for Next Generation Networks

The Telegra Voice Quality Tester (VQT) is an objective voice quality test system providing detailed analysis on the determining parameters for every voice network: clarity, delay, and echo. For voice services of next generation networks such as VoIP to be successful, they must meet or exceed the voice quality of traditional phone networks. The Telegra VQT provides the ability to objectively compare voice quality and to identify the influencing factors. Standard telephony interfaces allow the VQT to connect to the access points of the network to determine how the end-user experiences voice quality. The VQT is designed for engineers who develop, deploy, and operate next generation voice network devices and services:

- Identify faulty system components in voice networks and network devices
- Improve network and system performance
- Shorten development, integration, deployment, and troubleshooting times

#### Introduce New Products and Network Services Sooner

The Telegra VQT helps you get products and services to market earlier with higher confidence. Locate subtle problems early in development or deployment when they are much less expensive to fix. Telegra VQT's comprehensive test capabilities enhance product and service quality and reliability.

### Shorten Development, Integration, Deployment, and Repair Times

- Fine tune your network equipment under real network conditions before field deployment.
- Determine the effect of network or system changes by easily comparing measurement results before and after the change.
- Simulate network changes in the lab before deployment. Use previously captured network behavior and change network parameters such as delay, e.g., to simulate additional nodes or longer routes.
- Automate voice quality tests. Use provided test scripts, modify existing ones, or develop your own.

### Key Measurements and Functionality

- Voice clarity measurement using the Perceptual Analysis Measurement System (PAMS)
- Voice clarity measurement via PSQM+, an enhanced version of the ITU P.861 recommendation for Perceived Speech Quality Measurement
- Voice delay
- Echo PACE—Perceived Annoyance Caused by Echo
- Echo Doubletalk—Network performance during doubletalk
- Voice Activation Detection Analysis—determines the effectiveness and impairments of Silence Suppression
- DTMF signal analysis
- One-way and round-trip measurements
- Automated and interactive test modes
- Network simulation

### Advisor VoIP Analysis

Voice Over IP (VoIP) applications on the industry renowned Agilent Advisor offers Line-Rate and Real-Time analysis for LAN, WAN, and ATM networks. Solutions address voice and fax signaling and Voice Packet IP QoS. Expert analysis tracks each state of the VoIP Call Control and voice transport process and automatically detects errors and protocol anomalies. In addition detailed examination, packet by packet is offered through clear and accurate decodes and Real-Time filtering. The Advisor analyzes the most extensive list of VoIP protocols in the industry today and this is now augmented with the addition of MEGACO/H.248. VoIP solutions are available from two software packages. The J4617A Voice and Fax over IP Protocol Analysis Software and the J4618A RTP QoS Monitor (RQM) Software. The RQM measures IP Quality of Service for voice over IP traffic using RTP (Real-Time Transport Protocol).

### Product Details

- J4618A RTP QoS Monitor Software (RQM) and H.323 Expert Commentators

The Telegra RQM (RTP QoS Monitor) J4618A software measures the IP packet performance of Voice over IP networks. Specifically, packet loss and jitter is measured for each session or conversation using RTP to transport voice or video. This software package also delivers Expert Commentators for H.323 signaling.

### Key Features

- Portable RTP voice and video packet monitoring
- Ethernet 10/100 Mbps interfaces supported
- Packet loss and jitter calculated for each individual RTP stream
- Graphs packet loss and jitter over time
- Graphs of statistical distribution of RTP packet loss and jitter values
- User-configurable alarms for RTP errors and excessive jitter and packet loss
- Continuous unattended logging of RTP packet loss and jitter statistics
- Continuous unattended logging of RTP errors
- Comprehensive Real-Time Expert Commentators for VoIP
- Signaling and Voice packet transport.
- Automatically detects Errored Call Set-Up and Tear Down
- Generates Warnings for non-Standard Protocol Behavior
- Measures Gatekeeper Performance
- Alerts the user to slow IP network and VoIP device performance.
- Draws attention to VoIP device incompatibility
- Call Detail Records for each call or part call

### Key Literature

VQT, Product Overview, p/n 5968-7723E  
 VQT, Technical Specifications, p/n 5968-8811E  
 VoIP, Product Overview, p/n 5968-6386E  
 RQM, Product Overview, p/n 5968-7724E

### Ordering Information

#### For VQT

**J1981A** Telegra VQT base platform, no interface  
**Opt 200** Dual-port analog FXO and dual-port analog E&M interface  
**Opt 201** Dual-port T1 interface  
**Opt 202** Dual-port E1 interface  
**Opt 400** PAMS license  
**Opt 401** PSQM license

**J1982A** PAMS upgrade for previously purchased VQT

**J1983A** PSQM upgrade for previously purchased VQT

**J1984A** T1 upgrade for previously purchased VQT

**J1985A** E1 upgrade for previously purchased VQT

**J1986A** Analog upgrade for previously purchased VQT

#### For RQM

**J4618A** RTP QoS Monitor software (RQM)

For more information visit our web site at:  
[www.agilent.com/comms/onenetworks](http://www.agilent.com/comms/onenetworks)

**Protocol Analyzers**

- 3 Dimensional Network Testing AC  
5963-1054EN/EUS
- Announcing New Multiprong Testing Brochure  
5091-7635E
- Frame Relay Message Sets Technical Specifications  
5963-0085EN/EUS
- Frame Relay Test Software Technical Specifications  
5963-6653EN/EUS
- Frame Relay/SMDS Seminar Book Solution Note  
5963-9501E
- Group 4 Fax Testing Product Note  
5091-2002E
- Integrated FR Testing with PT502 Data Brief  
5091-2003E
- Integrated SMDS Testing with PT502 Data Brief  
5091-2006E
- ISDN Primary Rate Testing Solution Note  
5963-2013EN/EUS
- ISDN Testing Data Brief  
5091-2141E
- Executable Test Suites for PT Series Technical Specifications  
5963-1090EN
- Protocol Testing at Bank of Montreal Solution Note  
5962-9750EN/EUS
- PT Series Technical Specs Technical Specifications  
5963-0082E
- V3.0 Test Software Technical Specifications  
5963-0086EN/EUS
- X.25 Protocol Testing Tech Data Technical Specifications  
5962-8746EN/EUS
- X.25/X.32/X.75 Testing with Agilent Ts Brochure  
5091-7847E
- Intuitive Signaling Analysis for Fixed and Wireless Networks  
5968-2796E

**Digital Transmission Testers**

- NIU Quick Isolation of DS3 Network Problems  
5965-8345E
- 3-Slot and 12-Slot Equipment Shelves for E4586A DS3 NIU  
5963-7141EUS
- E485XA Serial Cell Generator and Analyzer  
5963-9924A
- 37722/32A Brochure  
5965-3192E
- 37722/32A Configuration Guide  
5965-3194E
- 37722/32A Technical Specifications  
5965-3193E
- E4540A DNA Software Brochure  
5964-2240E
- 71603B Brochure  
5965-1431E
- T1 Test Advisor Testing Just Got Easier Brochure  
5967-6060E
- E1 Test Advisor Brochure  
5967-6161E
- HDSL Installer's Assistant Brochure  
5965-8937E
- 71612B Brochure  
5968-2810E
- General Purpose Instruments Catalog  
5968-8736EUS/EN
- (PN E4540A) Automated Test Sequences for More Effective Testing of SDH and ATM Networks  
5965-4911E
- (PN E4540E) Interactive Diagnosis for More Effective Support of SDH and ATM Networks  
5965-4912E
- (PN 71612B) Locating Errors in Gigabit Transmission Systems and Components  
5968-2811E
- (PN 71612B) Extending Hi-Speed BER Testing to 20 Gb/s  
5964-6133E
- (PN 71612B) Testing 10 GB/s SONET/SDH Equipment and Components  
5968-2812E

**Error Performance Analyzers**

- 86130A BitAlyzer—Should a Bit Error Ratio measurement be hard to make? We don't think so. (Brochure)  
5968-8547E
- 86130A BitAlyzer Error Performance Analyzer Technical Specifications  
5968-8545E
- 86130A BitAlyzer 3.6 Gbit/s Error Performance Analyzer Product Demonstration  
5968-9432E
- 86130A BitAlyzer Enhanced Error Analysis Options Product Overview  
5980-0913E

**SONET/SDH Test Sets**

- E4480A CERJAC 156 MTS Brochure  
5966-2243E
- E4480A 156 MTS Technical Data  
5963-2178EUS
- E4487A CERJAC Series 31XE Technical Data  
5964-2463EUS
- 37718A OmniBER 718 Product Note  
5968-2041E
- 37719A OmniBER 719 Brochure  
5968-0761E
- (PN E4480A/87A and E4595) Enhanced, Easy-to-Use SONET and T-Carrier Testing  
5965-3650E
- (PN E4480A/87A) Graphical Control, Measurement and Analysis  
5965-3648E
- (PN OmniBER 718) PDH Digital Radio Test  
5965-4885E
- (PN OmniBER 718) Tributary Jitter Testing of SDH Network Equipment Using ITU-T G.783 Pointer Sequences  
5965-4862E
- (PN OmniBER 718) Automatic Verification of Network Equipment to ITU-T Jitter Tolerance Recommendations  
5965-4863E
- (PN OmniBER 718) Resolve Finger-Pointing Problems on 140 Mb/s Transport Signals  
5965-4886E
- ((PN OmniBER) Professional Measurement Results Report—At Your Fingertips  
5968-2041E
- (PN OmniBER) STM-16c/OC-48c Concatenated Payloads: Essential for Testing DWDM and Broadband Systems  
5968-2040E
- (PN OmniBER) Verifying Protection Switching Mechanisms in Linear and Ring Topology Networks  
5965-9915E

**ATM/Broadband Test Systems**

1993 B-ISDN Seminar Handbook Primer  
[5962-8794E](#)

1994 B-ISDN Seminar Handbook Primer  
[5962-0011E](#)

1995 Broadband Communications Map  
[5963-9489E](#)

BSTS Product Ordering Guide  
[5964-0393E](#)

Conformance and Interlop Testing—  
What You Must Know  
[5965-1457E](#)

Broadband Series Test System Product Information  
[5966-0035E](#)

Implementing ATM Signalling Solution Note  
[5963-7514E](#)

MPEG-2 Digital Video Technology  
Solution Note  
[5963-7511E](#)

Traffic Policing Solution Note  
[5963-7510E](#)

WAN Interworking with ATM Solution Note  
[5963-7512E](#)

E4829B Product Overview  
[5964-1667E](#)

E4829B Technical Data Sheet  
[5963-9923E](#)

Ease Your Network's Migration to ATM  
Brochure  
[5965-4968E](#)

ATM Testing and LAN Connectivity  
Measurements Under One Handle  
Brochure  
[5966-3293E](#)

E5200A Broadband Service Analyzer  
Technical Data  
[5965-1376E](#)

Broadband Service Analysis—Coping with the  
Network Test Challenge White Paper  
[5965-1377E](#)

OmniBER 717 (37717C) Brochure  
[5964-5817E](#)

OmniBER 717 (37717C) Technical Specifications  
[5968-3132](#)

(PN E4200, 10, 17A) NNI Signalling Test Software  
Helps Ensure Seamless ATM Networks  
[5965-6307E](#)

(PN) Proceedings of the 1995 B-ISDN/ATM  
Protocol Testing Seminar (E4200B, E4210B)  
[5964-3579E](#)

(PN E4821A, E4829B, E4885A) Implementation  
of UTOPIA Level 2 for Parallel Cell/Traffic  
Generator and Analyzer  
[5965-4856E](#)

(PN E4829B) Cell Transfer Time Measurement  
Using the Parallel Cell/Traffic Generator  
and Analyzer  
[5965-5297E](#)

(PN E482xA/B, E4889A) Real Time Bit  
Error Rate Analysis at Parallel Interfaces  
(UTOPIA) with E4829B  
[5965-4855E](#)

(PN E4505A-2) Test Sequences for More  
Effective Testing of SDH and ATM  
[5965-4911E](#)

(PN E4505A-2, 37717B/C) Interactive Diagnosis  
For More Effective Support of SDH and  
ATM Networks  
[5965-4912E](#)

(PN OmniBER 717) Physical Layer Jitter Testing  
in an ATM Environment  
[5965-4861E](#)

**Field Installation & Maintenance**

Power Meter Sub-module E6007A and  
Visual Fault Finder Sub-module E6007A,  
Photo Card  
[5966-0022E](#)

Multimode OTDR Modules E6005A, E6009A,  
Photo Card  
[5966-0023E](#)

E6053A, E6058A, E6060A Rack OTDR  
Photocard  
[5966-4227E](#)

ODTR Family Accessories Photocard  
[5966-4878E](#)

## Agilent's web site: Get news, updated product and support information, and more, 24 hours a day.

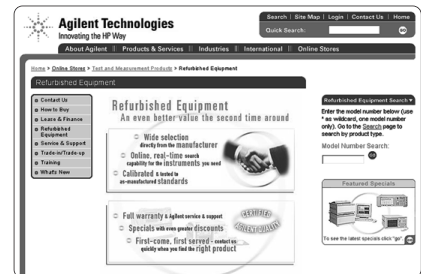
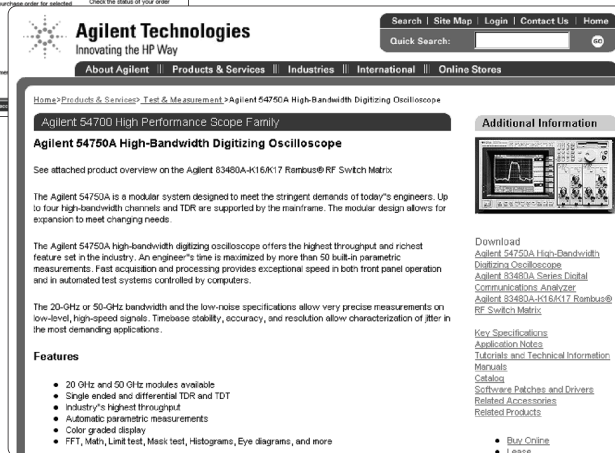

### Resources Available Online

- Product and support information more easily with helpful navigation aids and improved web pages that make it easier to access application notes, product overviews, technical details, frequently asked questions, manuals, software, news releases, education course descriptions and schedules, and much more.
- Updated comparison data and evaluation guides/tools that facilitate product selections
- Helpful application notes, downloadable interactive application notes, tutorials, online models, and other learning and problem-solving material
- Quick access to customer support services
- Information on recommended replacements for discontinued products
- Information in your local language\*
- The latest information on the status of your Agilent test and measurement order

### Take Action

- Selected Agilent products—including scopes, logic analyzers, EDA software, multimeters, data acquisition products, signal sources, counters, power supplies, and more\*
- Refurbished instruments\*
- Accessories\*
- Replacement parts\*

For more information on the test and measurement features, resources, and services available on Agilent's web site, see page 3.

Use our online test and measurement resources and services often!  
[www.agilent.com/find/tmc](http://www.agilent.com/find/tmc)

\*Availability of this feature may be limited; an expansion program is ongoing. Online purchases require a credit card.

For best results, view the Agilent web site with Microsoft's Internet Explorer browser.



**Overview** 422

**Electronic Warfare, Radar,  
Weapons & Satellite  
Test Solutions** 423

**Signal Analysis** 425

**Physical Test** 426



## Into the Future

### Defense Electronics and ATE, Broadband Communications, Communications Intelligence, Structures and Propulsion

Together, we can look farther forward to anticipate—and apply—the latest advances in electronic technology, accelerating your progress toward new successes in aerospace and defense.

The challenge of designing automated test systems for aerospace and defense applications is to find test solutions that meet your toughest requirements for test equipment:

- Off-the-shelf
- Downsized
- Transportable
- High-performance

These challenges become even more difficult with the increasing need for equipment that can test at higher microwave frequencies and at wider bandwidth.

For over 10 years, Agilent has been committed to a flexible, standard foundation that meets these needs. We combine VXI-based systems and system building blocks with measurement expertise and worldwide support. Whether you are experimenting with leading-edge communications technologies or maintaining automated test systems deployed worldwide, Agilent's test solutions will provide the latest advances in electronic technology to accelerate your progress toward new successes.

This year's new product line-up supports the need for increasing frequencies and bandwidths with the introduction of the 89600A vector signal analyzer and the E6432A microwave signal simulation source. The combination of these two products creates a stimulus-response system—all in the VXI format—that can meet your performance and program needs.

### VXI for Automated Test

In the commercial world, the goal is to create quality products and get them to market first. Agilent can help by providing test systems you can count on—systems that deliver reliable and repeatable measurements in manufacturing and for design verification. Agilent's commitment to VXI can take you where you need to be.

A test platform based on the VXIbus standard delivers flexible measurement components, powerful software and development tools, and system interfaces that work together to help accelerate test throughput.

Test engineers who use the VXI test platform are achieving improved quality, increased throughput, greater performance, and lower operating and maintenance costs.

### Broadband Communications

The communications business has changed, driven by the pace of the Internet. Success depends on the ability to anticipate new technologies, launch an information infrastructure, and build solid partnerships—fast. The emerging technology of broadband communications will enable businesses and

consumers to access high-speed data almost anywhere in the world. For example, digital cable modems will provide high-speed Internet connections to homes and businesses—increasing data rates from the current 56 kb/s to 10 Mb/s and faster. The E1371A Data Over Cable Service Interface Specification (DOCSIS) Test System is a design verification and pre-certification tool that accelerates the certification process for cable modem vendors. The system's automatic features and software reduce test time and measurement uncertainty.

### Agilent's Commitment to Standards

You have been telling the industry, "We want to get the same measurement answer even if we change the instrument." We are helping develop the solution to "different asset, same answer." Interchangeable virtual instruments (IVI) is a proposed test and measurement instrument driver standard that builds on the *VXIplug&play* specifications. Designed to help test system developers, the proposed IVI specification can save engineering departments time and money by offering standardized software interfaces for common instrument classes. Those capabilities make it possible to reuse more of your existing software, and that reduces test system development time.

If you are interested in web-based information, visit our website at [www.agilent.com/find/AD](http://www.agilent.com/find/AD)

If you are interested in more information on Agilent's role within the IVI Foundation, please visit: [www.tm.agilent.com/tmo/techinfo/English/ivi-main.html](http://www.tm.agilent.com/tmo/techinfo/English/ivi-main.html)

### High Performance Tools in Radar/EW

Advanced microwave applications involve high-performance microwave frequency synthesized signals in radar/EW. The measurement challenges faced by designers, manufacturers and end-users in these advanced microwave applications require fast switching speed, low phase noise, high spectral purity, and synthesizer accuracy all in the small footprint required by the next generation of microwave signals.

Agilent understands these challenges and has created a tool with high-performance microwave capability in the VXI format. The E6432A VXI microwave synthesizer ushers in the next generation of microwave synthesized signal sources, designed for automated test equipment (ATE) systems. Please refer to page 202 for more information on the E6432A VXI microwave synthesizer.

You can also order the E6432A with I/Q capability, and when combined with an external arbitrary waveform generator, like the Racal 3153, provides 40 MHz of bandwidth

In addition, designers, manufacturers and end-users in these application areas require transient analysis, phase noise analysis, and precision amplitude and phase measurements. Complete characterization of signals requires instrumentation capable of high-speed capture and analysis in both the frequency and time domains. Please refer to page 90 for more information on the 70000 modular measurement system.

The steady advance of commercial technology lets you create systems that are changing the nature of conflict. The challenge of designing automated test systems for those applications is to find solutions that meet your toughest requirements: off-the-shelf, downsizeable, transportable and high-performance. For over 10 years, Agilent has been committed to a flexible, standard foundation that covers higher microwave frequencies and wider bandwidths. Products, solutions, and services from Agilent deliver confidence in the operational status of your electronic systems and subsystems – for the life of those systems.

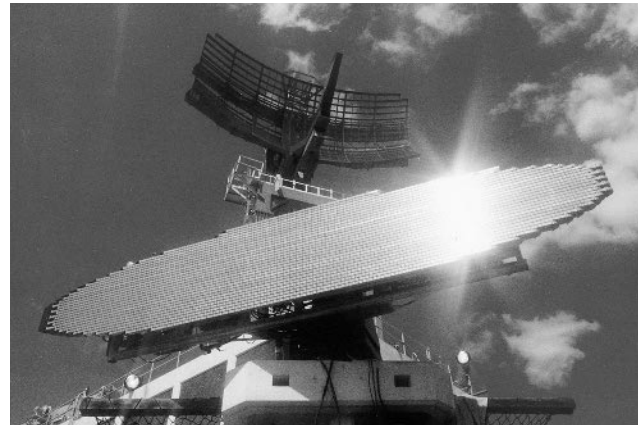

EW Radar

E6432A  
70000

### Agilent's commitment to test and measurement standards

The inconsistency – and difficulty – of software drivers for test and measurement instruments often frustrates test engineers. Interchangeable virtual instruments (IVI), is a proposed driver standard that can reduce development time by offering standardized interfaces for common instrument classes. Agilent is helping push IVI one step further to provide the ability to change instruments in deployed systems without having to modify the system software. An IVI subgroup is evaluating how to extend the standard to include a layer currently called measurement and stimulus subsystem (MSS) providing that functionality.

To learn more about Agilent's solutions for automated test systems visit our website at: [www.agilent.com/find/defense\\_ATE](http://www.agilent.com/find/defense_ATE)

### Key Literature

Test System & VXI Products Catalog, p/n 5980-0307E  
E6432A VXI Microwave Synthesizer, Configuration Guide, p/n 5967-6272E  
Into the Future, Brochure, p/n 5980-0309E

### Ordering Information

Prices vary. For more information, please contact your Agilent Technologies sales representative.



E6432A

85121A

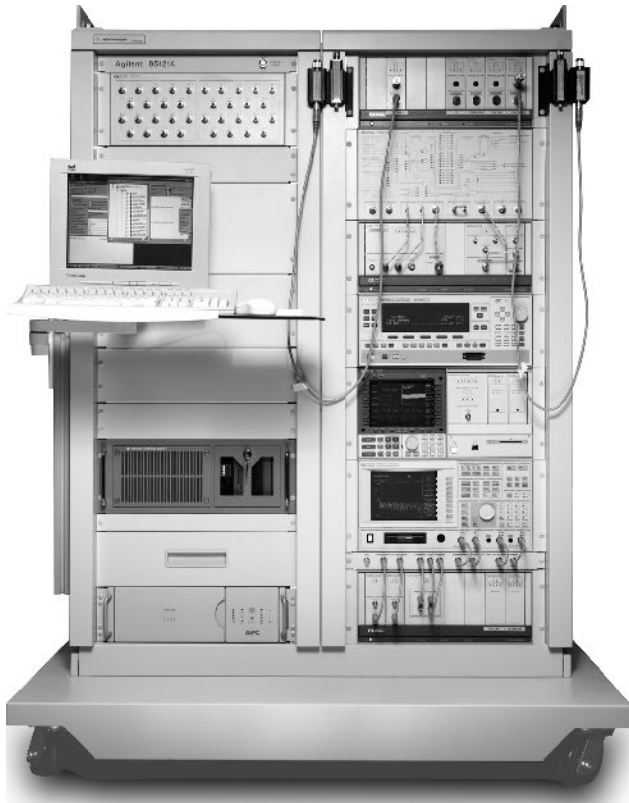

85121A

## Payload Test System Configuration

The 85121A Payload Test System (PTS) is an automated system for evaluating the microwave frequency performance of communications satellite transponders, telemetry transmitters, and command receivers. The PTS presented in this document is Agilent's typical configuration, which can be customized for specific measurement requirements.

The 85121A PTS integrates instrumentation hardware and software to provide a flexible, mobile test system that meets the needs of many test environments in satellite manufacturing and pre-launch operations. Automatic measurements in the Windows NT operating environment provide an easy-to-operate system that significantly reduces test time. Satellite manufacturers using Agilent's PTS have reduced integration and test cycle time, resulting in reduced labor costs and faster time to satellite launch.

The typical PTS instrumentation configuration is mounted in a rack assembly optimized for mobility within the factory for various testing stations: integration and test, highbay, antenna range and thermal vacuum test facilities. Because of its compact size, the PTS can also be moved to a launch site for post-transport and pre-launch spacecraft testing.

The PTS design is based on years of Agilent experience at providing test systems to the major satellite-industry manufacturers worldwide for testing components, subsystems, antennas and payloads. The 85121A PTS provides consistent, repeatable measurements throughout the integration and test manufacturing process. Therefore, the user can expect a high degree of correlation between measurements made during different stages of manufacturing, from panel and payload through spacecraft testing.

The typical PTS has the following characteristics:

- Single channel operation (a second channel can be added with another PTS rack.)
- Single- and two-tone measurements
- 1–20 GHz frequency coverage
- 18 uplink and 18 downlink ports

Enhancements are available for the typical PTS, and Agilent can evaluate customer-requested customizations for feasibility, cost, and delivery. Some PTS options currently available include the following:

- Frequency extensions
- UHF band: 100–1000 MHz
- Ka-band: 27.5–31.0 GHz uplink, 18.0–21.2 GHz downlink
- Multiple-tone measurements
  - Noise power ratio (NPR)
  - Error vector magnitude (EVM)
- Specific number of uplink and downlink ports
- Additional channels

The communications business has changed, driven by the pace of the Internet. Success depends on the ability to anticipate new technologies, launch an information infrastructure, and build solid partnerships—fast.

Choose Agilent when looking for tools, solutions, and services that decrease the complexity of test and measurement.

To learn more about Agilent's solutions for broadband communications visit our websites at: [www.agilent.com/find/satcomm](http://www.agilent.com/find/satcomm) or [www.agilent.com/find/89600](http://www.agilent.com/find/89600)

## Key Literature

85121A Payload Test System Family, Product Overview, p/n 5968-5661E  
Into the Future Brochure, p/n 5980-0309E

## Ordering Information

Prices vary. For more information, please contact your Agilent Technologies sales representative.

## Satellite Payload Test Systems

Today's satellite designs incorporate the latest in technology, resulting in smaller, lighter, less expensive systems packed with more functionality. Manufacturers are under pressure to design and deliver these next generation satellites on time, within budget, and with high quality assurance. Satellite manufacturers of Ka-band digital regenerative communication payloads have turned to Agilent for customized automated payload test systems that improve measurement repeatability and reduce test and integration time. Customers who have worked with Agilent to develop complex payload test systems now enjoy flexible platforms for reuse across multiple payload programs and for consistent, repeatable measurements between manufacturing sites and across the manufacturing lifecycle.

### 85121A Payload Test System Family

#### Product Overview

Satellite-industry manufacturers have shown that automated payload testing improves measurement repeatability and reduces test time, resulting in faster satellite integration cycle time.

- Standard system configuration for 1–20 GHz testing applications
- Frequency extension options available for UHF and Ka-bands
- Single setup for testing for multiple transponders
- Complete suite of response and distortion measurements
- Easy-to-use system software in Windows NT environment
- High measurement repeatability through automated system calibration
- Customization available for specific requirements

The typical payload test system is customizable for specific measurement requirements.



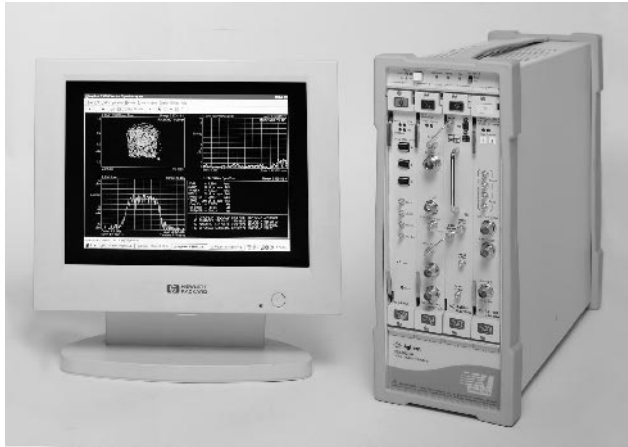

E3238 signals development system

## Reducing Your Risk in Surveillance

Agilent delivers systems and services tuned to the needs of major land, sea, air, space, and communications intelligence programs.

Today's crowded airwaves contain signals that present new challenges in communications intelligence. Operational realities compound the problem: you are expected to develop more signals with less equipment and fewer people. Now, more than ever, successful missions depend on high productivity from systems, operators, and those who support them. Adaptable and dependable Agilent COMINT systems—based on COTS components—provide development and operations functions that enhance productivity. And, our modular approach to hardware and software protects your investment, now and in the future. Working together, we can look farther forward to anticipate—and apply—the latest advances in electronic technology, accelerating your ability to deploy systems quickly and generate product rapidly.

## Search, Classify and Analyze

The E3238 signals development system helps you search for, classify and analyze signals of interest. It provides four key attributes:

### High Performance

- Wideband architecture speeds energy search
- High dynamic range RF hardware handles dense signal environments
- Multiple DSP/CPU architecture enhances speed and flexibility

### Increased Productivity

- Automated tasking
- Customizable energy filters, displays, GUIs, and more
- Training for developers and operators

### Flexible and Supportable

- Industry standard VXI platform
- Open systems-based hardware and software architecture
- Modular and upgradable
- Proven with installations around the world

### Versatile Integration

- TCP/IP, RS-232C, and GPIB are standard interfaces
- High and low bandwidth remote communication modes

## Create Enhanced Functionality

Expand the capabilities of your E3238 signals development system and reduce your signal processing software development time by adding Option ASH, use signal processing. This option helps you write and integrate your narrowband signal processing algorithms into the E3238.

## Turn Over Some Rocks

Working with hard-to-measure signals—burst, hopped, modulated—is a fact of life when dealing with today's high performance communication systems. Analyzing a new signal takes high performance DSP tools. The 89600A vector signal analyzer is a VXI-based tool to measure wideband signals and combines time-, frequency-, and modulation-domain analysis tools to provide measurements and displays that help you analyze today's complex digital signals. With the 89600A, you can uncover things you couldn't do before—and they're things you really want to see.

## Key Products

### 3587 Real-time Signal System

The 3587 real-time signal analysis system has the measurement power and flexibility you need to capture and analyze real-world signals. Its combination of speed, dynamic range, presentation flexibility, and signal capture memory will help you analyze non-stationary and low-level signals—even those close to much stronger signals—a higher percentage of the time. For more information, please see page 339.

### E3238 Signals Development System

The E3238 signals development system is a turnkey, VXI-based solution for high-speed search, classification, monitoring, and real-time signal demodulation. This high-selectivity receiver has the manual and automatic tools you need to detect, classify, and monitor signals of interest. Detected signals are automatically entered in a signal database. Option AS9 and ASH let you hand off signals of interest to VXI narrowband receivers that can tune to the signal of interest and record, or even decode, the message in real-time, whether it is voice or data.

Using digital technology, the E3238 improves search speed by 10 or 100 times over narrowband search techniques used in swept systems. For more information, please see page 340.

To learn more about Agilent's solutions for communications intelligence visit our website at: [www.agilent.com/find/COMINT](http://www.agilent.com/find/COMINT)

## Key Literature

Into the Future, Brochure, p/n 5980-0309E

## Ordering Information

Prices vary. For more information, please contact your Agilent Technologies sales representative.

3587  
E3238

9

E1529A  
E9801A  
E9812A  
E9814A



### The Right Results at the Right Time

Aircraft, launch vehicles and other systems have to withstand tremendous physical demands, and the consequences of failure are substantial. System requirements such as lighter weight and lower cost have led to innovative structures and materials that require thorough testing and analysis. If the test article is one of a kind, the test team needs to quickly acquire hundreds of data points – and hundreds of megabytes of data – for detailed analysis. Agilent offers a unified set of measurement tools that can end the usual frustration of configuring a test system, acquiring the right data, analyzing the data, and producing a report. By streamlining that process, Agilent data acquisition and control (DAC) systems enable your real contribution: making the right recommendation, or reaching the right conclusion, on time and within budget. Agilent DAC solutions extend your engineering senses and accelerate your progress towards the right results at the right time.

Agilent DAC solutions rely on industry standards –VXI, UNIX, Windows NT– to provide dependable systems that meet those needs. Agilent scanning digitizers, for instance, are ideal for applications that require static measurements and control of the test article. For dynamic and transient measurements, our high-speed digitizers, signal processors, and mass-storage modules excel in noise, vibration, and structural applications. And built-in or plug-on signal conditioners provide a cost-effective way to handle various test requirements.

### Understand the Physical Properties

Comprehensive physical testing includes measurements of temperature, pressure, strain, noise, and vibration. Those properties, measured accurately, help verify the computer models of your designs. The necessary data comes from tests that range from strain on an airframe, to excitation and modal analysis of a launch vehicle, to vibration profiles of a jet engine. Meeting shorter project schedules requires the ability to quickly configure tens or hundreds of inputs, verify the quality of the data, acquire and archive large amounts of data, and perform detailed analysis on the stored data. During environmental tests, a combination of static, transient, and dynamic measurements must be acquired without missing any data. Off-the-shelf application software enables solutions such as: general vibration analysis, multiple-input modal analysis, engine analysis with order tracking, closed-loop vibration control, shock testing and acoustic analysis.



E1529A

### Key Products

#### E1529A Remote Strain Conditioning Unit

The E1529A remote channel strain-conditioning unit offers low cost-per-channel in strain-bridge signal-conditioning for static-load and vibration testing. The E1529A is designed to simplify stress and fatigue testing of large mechanical structures such as airframes and rockets. Each 32-channel unit features built-in signal conditioning and multiplexed connections, which reduce overall system cost. Strain gage connections – as easy as plugging in a telephone – shorten system set up time. For more information, please see page 424.

#### DAC Express Data Acquisition/Recorder Software

DAC Express (E9801A) is a Microsoft Windows-based package that improves productivity for mechanical designers and engineers who test product functionality, specification margins, durability and more. With no programming necessary, DAC Express speeds up and simplifies the process of system development, data validation, archiving, analysis and report generation. The result is more time for the important tasks of design verification and enhancement. Two DAC Express system bundles are also available: the E9812A data logger and the E9814A data recorder/logger. For more information, please see pages 530 and 531.

### Key Literature

Into the Future, Brochure, p/n 5980-0309E

To learn more about Agilent's solutions for measurement and analysis of physical properties, visit our website at [www.agilent.com/find/structural](http://www.agilent.com/find/structural)

### Ordering Information

Prices vary. For more information, please contact your Agilent Technologies sales representative.

## Agilent's web site: Get news, updated product and support information, and more, 24 hours a day.

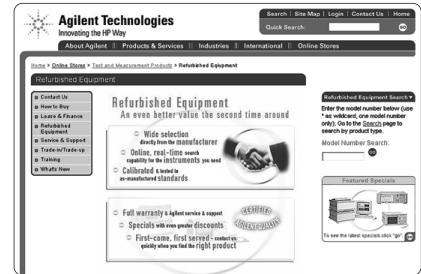
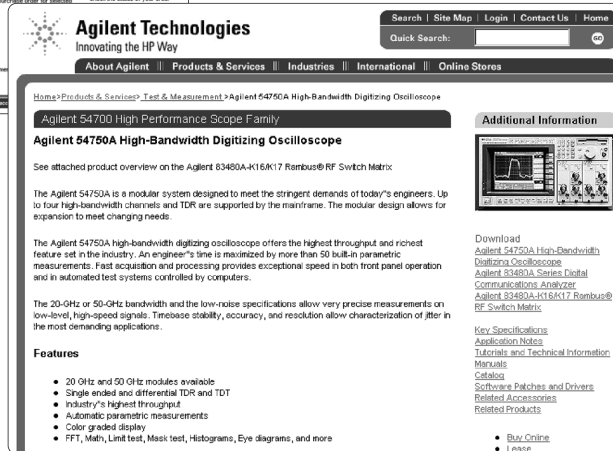

### Resources Available Online

- Product and support information more easily with helpful navigation aids and improved web pages that make it easier to access application notes, product overviews, technical details, frequently asked questions, manuals, software, news releases, education course descriptions and schedules, and much more.

- Updated comparison data and evaluation guides/tools that facilitate product selections
- Helpful application notes, downloadable interactive application notes, tutorials, online models, and other learning and problem-solving material
- Quick access to customer support services
- Information on recommended replacements for discontinued products
- Information in your local language\*
- The latest information on the status of your Agilent test and measurement order

### Take Action

- Selected Agilent products—including scopes, logic analyzers, EDA software, multimeters, data acquisition products, signal sources, counters, power supplies, and more\*
- Refurbished instruments\*
- Accessories\*
- Replacement parts\*

For more information on the test and measurement features, resources, and services available on Agilent's web site, see page 3.

Use our online test and measurement resources and services often!  
[www.agilent.com/find/tmc](http://www.agilent.com/find/tmc)

\*Availability of this feature may be limited; an expansion program is ongoing. Online purchases require a credit card.

For best results, view the Agilent web site with Microsoft's Internet Explorer browser.

**Debug Tools and Solutions** Agilent Technologies' digital debug tools and solutions help you navigate through the sometimes uncertain processes of board turn on, prototype debugging, hardware/software integration, and functional testing

The 16700 Series Logic Analysis Systems combine logic analysis and emulation to provide a complete view—from hardware to software—of digital system prototypes.

The 1660/70 Series Benchtop Logic Analyzers allow you to choose from capabilities such as basic hardware/software debugging, parametric and mixed signal testing, hardware simulation and stimulus/response testing, and complex debugging with deep memory, in a number of affordable models.

**Verification Tools and Solutions** Agilent's digital verification tools and solutions offer a range of tools that help to evaluate, optimize and validate the behavior of your PCI/PCI-X system or component.

Agilent's PCI/PCI-X Exerciser and Analyzer is a PCI/PCI-X optimized state logic analyzer and data generator. It provides fully controllable system-tests, wide coverage, reproducibility, and root-cause-analysis capabilities that reveal system critical problems faster than any hot mock-up testing can.

**Characterization Tools and Solutions** Agilent's characterization tools and solutions offer a wide variety of pulse/pattern generators and the 81200 Data Generator/Analyzer Platform, which focus on functional and parametric testing of digital and high-speed devices.

The 81200 provides stimulus and response capabilities as well as parallel bit-error-rate capabilities in one platform, to characterize and verify digital subsystems, ICs or boards in R&D and manufacturing.

Agilent's pulse/pattern generators are highly accurate digital sources for use across all industries

Logic Analysis Systems  
Emulation Solutions  
Microprocessor and Bus Interfaces  
Post-Processing Tools  
Benchtop Logic Analyzers

PCI/PCI-X Exercisers and Analyzers

Data Generator/Analyzer Platform  
Pulse/Pattern Generators



Characterization Tools & Solutions 430

Verification Tools & Solutions 440

Logic Analysis & Emulation Solutions 442

Additional Literature 463

81200  
E4839A

- Characterizes digital hardware from ICs to systems
- Integrates easily into standard VXI test platforms
- Function and margin tests, error analysis
- Stimulus and response in one platform
- Up to 2.67 Gb/s
- Up to 240 channels
- 100 ps resolution, 50 ps accuracy
- Semi-automatic deskew
- Auto adjustment of the analyzers' sampling point

### Confirm Digital Hardware Early in the Product Cycle

The Agilent 81200 Data Generator/Analyzer Platform helps engineers in design and engineering environments to characterize digital hardware such as ICs, boards, modules, frames and systems. With the 81200 you can characterize your DUT under near-to-real conditions at an early stage in the design or manufacturing cycle, thus reducing risks, costs and time-to-market.

### Application Examples

- CMOS, ECL, and LVDS logic characterization
- Emulate clock, data, and control signals
- Functional test, margin test, error analysis
- Computer clock, multi-phase clocks
- High speed DACs
- High speed memory test, e.g., RAMBUS

### Emulate the Device's Environment

Communication and computing devices can require very complex stimuli. To meet this need, the 81200 provides sequencing and looping, and with up to 8 Mb memory per channel you can generate very deep patterns. The internal editor includes memory-based prbs/prws (pseudo-random binary/word sequences) to simulate traffic and allow multiplexer testing. The system generates (pseudo-random binary sequences) up to  $2^{15}-1$ .

Programmable output levels, pulsewidth, delay, and transitions are independent for each channel so that performance at and beyond working conditions can be measured. RZ/NRZ (return to zero/non-return to zero) and R1 (return to one) formats are available. RC (return to complement) can be arranged by the logical addition of two channels using the EX-OR output addition feature. Analog addition of channels allows the generation of real-world signals, such as pulses with glitches, spikes, or reflection, as well as 3 and 4 level signals.

For high-speed devices, fast, stable edges with rates up to 2.67 Gb/s are available.

For less demanding applications (control signals, slower logic), dual output/input module front-ends are available, which can reduce investment.

### Easy Performance Measurement

Performance measurements are easy because they are implemented under the same user interface as the stimulus. The 81200 captures, and displays data in a state list. Data can also be compared in real time, with the results displayed as an error map, a state list, or as an error count or rate. Skews introduced by the user's cabling and fixturing can be compensated by a software-guided procedure (E4805B and Option 003 required).

### Bench and System Operation

Manual operation is via a Windows NT-based user interface. Channel allocation, pattern, and parameters are among the items that can be set up. Patterns can be imported and exported in ASCII via GPIB (SCPI), LAN or 3.5" disk. For system operation, the GPIB can be used in one of two ways: to control other GPIB instruments (for this, a suitable controller language such as C, Basic, or Agilent VEE must be installed by the user in the built-in PC), or another computer can control the 81200.

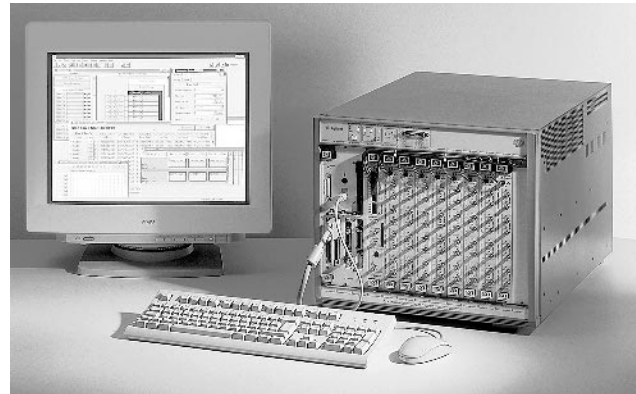

The 81200 Data Generator/Analyzer Platform

### Scaleable and Upgradeable

The modular structure (mainframes, modules, and module front-ends) allow required channel counts to be implemented economically.

The 81200 is supplied ready-to-use<sup>1</sup> with the desired number and types of channels. The software supports any channels that the user may choose to add at a later date. Additionally, the 81200 modules can be integrated easily into standard VXI test platforms with the supplied plug&play drivers.

<sup>1</sup>All software and hardware is in place and connected. However, expander modules and monitors are packaged separately, and these items must be connected for initial use. In the case of expander modules, the mainframe clock generator must be removed and opened in order to connect a ribbon cable to the expander clock module(s).

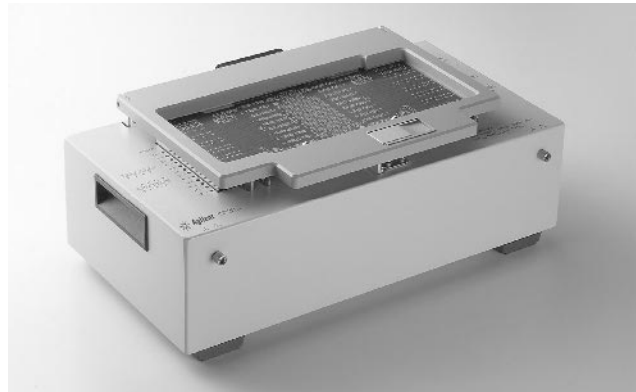

E4839A Test Fixture

### E4839A Test Fixture

The E4839A Test Fixture works with the 81200 to provide a complete solution for digital device characterization. The combination provides a 50 Ω signal path all the way from the 81200 platform port to the pin of the DUT. This provides a high-quality signal up to a data rate of 667 Mbit/s. Signals from other test equipment can also be connected to the DUT. The test fixture supports "Infinite Plane" DUT interface boards, and up to four power supplies.

### BestLink/81200 Simulation Data Link

You can now leverage the knowledge and data gained while simulating a new design by automatically moving simulation data to the prototype test setup.

BestLink/81200 is an intelligent EDA tool that employs a sophisticated algorithm that analyzes and converts your simulation data for your particular 81200 hardware configuration. BestLink/81200 is optimized to process simulation data coming from commercial VHDL and Verilog simulators.

BestLink/81200 is available from Diagonal Systems. For details, please refer to our web site: <http://www.diagonal.com>

### Data Generator Front-Ends

	E4838A	E4843A	E4846A	E4862A	E4864A
<b>Target logic</b>	LVDS, ECL, PECL, 3.3V CMOS	TTL, ECL, PECL	TTL, ECL, PECL	LVDS, ECL, PECL Low voltage CMOS	LVDS, ECL, PECL Low voltage CMOS
<b>Max. frequency</b>	667 MHz	667 MHz	200 Mbit/s	2.67 Gb/s	1.33 Gb/s
<b>Outputs (50 Ω)</b>	1, differential, 50 Ω	1, differential, 50 Ω	2, single-ended	1, differential	1, differential
<b>Data format</b>	RZ, R1, NRZ, DNRZ	RZ, R1, NRZ, DNRZ	NRZ, DNRZ	NRZ, DNRZ	NRZ, DNRZ
<b>Amplitude/resolution</b> 50 Ω into 50 Ω	<0.1 to 3.50 Vpp/10mV	0.3 to 2.50 Vpp/10mV <sup>4</sup>	0.3 to 3.5 Vpp/10mV <sup>4</sup>	0.05 to 1.8 Vpp <sup>3</sup> /10mV	0.05 to 1.8 Vpp <sup>3</sup> /10mV
<b>Window</b> 50 Ω into 50 Ω	-2.2 to +4.4V	-2.0 to +3.0V <sup>4</sup>	-1.75 to +3.50V <sup>4</sup>	-2.0 to +3.0V	-2.0 to +3.0V
<b>Transition time</b>	0.5 to 4.5 ns <sup>1</sup>	<350 ps, 200 ps typ. <sup>2</sup>	<1.2 ns, 700 typ. <sup>2</sup>	90 ps typ.@ECL, LVDS <sup>2</sup>	90 ps typ.@ECL, LVDS <sup>2</sup>
<sup>1</sup> 10–90% of amplitude	<sup>2</sup> 20–80% of amplitude	<sup>3</sup> Does not double into open	<sup>4</sup> Doubles into open		

### Data Analyzer Front-Ends

	E4835A <sup>2</sup>	E4847A	E4863A	E4865A	
<b>Sampling rate</b>	667 MSa/s	333 MSa/s	2.67 GSa/s	1.33 GSa/s	
<b>Inputs</b>	2, differential or single-ended (switchable)	2	1, differential or single-ended	1, differential or single-ended	
<b>Input sensitivity</b>	Differential 50 mV typ. Single-ended 100 mV typ.	200 mV typ.	50 mV typ.	50 mV typ.	
<b>Impedance</b>	50 Ω	50 Ω	50 Ω <sup>3</sup>	50 Ω <sup>3</sup>	
<b>Input threshold</b>	-2.0 to +4.5 V,	-2.1 to +5.1 V,	-2.1 to +5.1 V,	-2.1 to +5.1 V,	-2.0 to +3.0 V

<sup>2</sup>Occupies two front-end slots of the E4832A module  
<sup>3</sup>100 Ω differential if termination voltage is switched off

### Data Modules

	E4831A	E4832A <sup>1</sup>	E4841A	E4861A <sup>1</sup>
<b>Max. frequency</b>	667 MHz	667 MHz	667 MHz	2.67 Gb/s
<b>Front-end slots per module</b>	2	4	4	2
<b>Memory depth per channel</b>	1 Mbit	2 Mbit	1 Mbit	8Mbit
<b>Segments</b>	User defined patterns and PRBS			
<b>PRBS, PRWS</b>	2 <sup>n</sup> -1, n = 7, 9, 10, 11, 15	2 <sup>n</sup> -1, n = 7, 9, 10, 11, 15	2 <sup>n</sup> -1, n = 7, 9, 10, 11, 15	2 <sup>n</sup> -1, n = 7, 9, 10, 11, 15
<b>Delay range</b>	0 to 3.0 μs	0 to 3.0 μs	0 to 3.0 μs	0 to 300 ns

<sup>1</sup>Specifications valid with E4873A user software

### Clock Module

	E4805B
<b>Frequency range</b>	1 kHz to 667 MHz
<b>Resolution</b>	1 Hz
<b>Accuracy</b>	± 50 ppm with internal PLL ref.
<b>Clock jitter</b>	<10 ps rms (5 ps typ.)

### General

**Programming Interface:** GPIB (IEEE 488.2) and LAN interface to applications such as C, Visual Basic, VEE must be installed, or 81200 *plug&play* drivers

**Graphical User Interface:** Windows NT-based, color, on-line help, graphical sequencing and channel connection windows

**Save/Recall:** Multiple settings and test patterns can be stored in an internal database

**Built-in Diagnostics:** Module and system self-tests can be implemented

#### Mainframe Dimensions

E4849C: 352 mm H x 424.5 mm W x 631 mm D (14.08 in x 17.02 in x 25.24 in)

**Operating Temperature:** 10° C to 40° C

**Interfaces:** LAN 10baseT (AUI, BNC), RS232, SVGA port, SCSI, Centronics parallel port, mini-DIN connectors for keyboard and mouse, GPIB, 3.5" floppy drive

**Warranty:** 3 years

**Standards:** CE-mark, designed and produced according to ISO 9001, IEC1010-1, CSA 1010.1, En 55011/CISPR 11, Group 1, Class A +10 dB

For more information and related literature, visit our web site:

[http://www.agilent.com/find/81200\\_overview](http://www.agilent.com/find/81200_overview)

### Ordering Information

#### Mainframe

**E4849C** Mainframe with 13 slots (includes Windows NT operating system and HP E4873A user software)

**Opt 11** 3 slot controller

**Opt 12** 2 slot VXI controller

**Opt 13** IEEE 1394 PC link to VXI

**E4848B** Expander frame, includes E1482B VXI extender module and all cables for connecting to the mainframe. E4805B clock module required

#### Modules

**E4805B** 667 MHz clock module

**Opt 002** 8-line trigger input

**Opt 003** Deskew probe 1144A

**E4831A** 667 MHz clock and data module

**E4841A** 667 MHz data generator/analyzer module

**E4832A** 667 MHz data module

**E4861A** 2.67 Gb/s data module

#### Data Generator Front-Ends

**E4838A** 667 Mbit/s, variable transitions

**E4843A** 667 Mbit/s

**E4846A** 200 Mbit/s NRZ, dual channel

**E4862A** 2.67 Gb/s data generator front end

**E4864A** 1.33 Gb/s data generator front end

#### Data Analyzer Front-Ends

**E4835A** Two differential analyzer front ends, 667 MSa/s

**E4839A** Test fixture

**E4847A** Dual input, 50 Ω

**E4863A** 2.67 GSa/s analyzer front end

**E4865A** 1.33 GSa/s analyzer front end



Agilent Technologies' family of pulse/pattern generators enables you to choose the exact performance to fit your needs.

Pulse generators provide variable parameters for characterizing a wide range of digital technologies in use today. Good repeatability and a rich feature set help you make fast, credible measurements easily.

Pattern capability combined with pulse generator features adds a new dimension to your testing capabilities because you can now carry out function testing under worse case conditions. Thanks to the logical channel-add feature, you can also simulate distortion (such as unequal timing, glitches, and cross talk) and, with analog channel addition, 3-level signals can be generated, which further increases your ability to create real-life conditions. These capabilities let you test your device thoroughly, much earlier in the product cycle.

### Matching Your Needs Better

The Agilent Technologies range of pulse generators extends from the 8114A 100 V, 2A Pulse Generator to the 8133A 3 GHz Pulse Generator. The 81100 Family of Pulse/Pattern Generators bridges the extremes. In addition to replacing the 8110A Pulse Generator with a compatible instrument that offers new standards of reliability and performance; the family also provides a spectrum of instruments with the same look and feel. Cost-effective solutions are now available for simple low frequency applications right up to precision high-speed requirements.

### Selection Table

Agilent 81100 Family of Pulse/Pattern Generators

Mainframe	8114A	81101A	81104A	8110A <sup>1</sup>	81110A <sup>1</sup>	81112A	81130A	81132A	8133A
Channel module	included	included	81105A	81103A <sup>1</sup>	81111A <sup>1</sup>	81112A	81131A	81132A	included
Max clock rate	15 MHz	50 MHz	80 MHz	150 MHz	165 MHz	330 MHz	400 MHz	660 MHz	3 GHz
Max data rate	—	—	80 MBit/s	150 MBit/s	165 MBit/s	330 MBit/s	800 MBit/s <sup>4</sup>	1.32 GBit/s <sup>4</sup>	—
Accuracy									
Triggerable	± 5%+100 ps	± 5%	± 5%	± 5%+100 ps	± 3% <sup>2</sup>	± 3% <sup>2</sup>	—	—	—
With PLL	—	0.01%	± 0.01%	± 0.1%	± 0.01%	± 0.01%	± 0.01%	± 0.01%	± 0.5% (YIG)
Jitter, rms									
Triggerable	± 0.03% +25 ps	± 0.01% +15 ps	± 0.01% +15 ps	± 0.03% +25 ps	± 0.01% +15 ps	± 0.01% +15 ps	—	—	—
With PLL	—	0.001% + 15 ps	± 0.001% +15 ps	± 0.003% +20 ps	± 0.001% +15 ps	± 0.001% +15 ps	± 0.001% +15 ps	± 0.001% +15 ps	± 5 ps (YIG)
Width/delay									
Resolution	3 digits	3 1/2 digits	3 1/2 digits	3 digits	3 1/2 digits	3 1/2 digits	4 digits	4 digits	4 1/2 digits
Best case	10 ps	5 ps	5 ps	10 ps	5 ps	5 ps	2 ps	2 ps	1 ps
Accuracy	± 5% ± 250 ps/ ± 1 μs	± 5% ± 500ps/ ± 1 μs	± 5% ± 250/ 500 ps	± 5% ± 250 ps/ ± 1 μs	± 3% <sup>2</sup> +250/ 500 ps	± 3% <sup>2</sup> +250/ 500 ps	0.01% +200/ 100 ps <sup>3</sup>	0.01% +200/ 100 ps <sup>3</sup>	150 ps
Jitter, rms	± 0.03% +25 ps	± 0.01% +15 ps	± 0.01% +15 ps	± 0.03% +25 ps	± 0.01% +15 ps	± 0.01% +15 ps	± 0.001% +15 ps	± 0.001% +15 ps	± 5 ps
Transition time	7 ns	5 ns	3 ns	2 ns	2 ns	0.8/1.6 ns	0.8/1.6 ns	0.5 ns	100 ps
Fixed/variable	Fixed	Variable	Variable	Variable	Variable	Selectable	Selectable	Fixed	Fixed
Output into 50 Ω									
50 Ω source	50 Vpp	10 Vpp	10 Vpp	10 Vpp	10 Vpp	3.8 Vpp	3.8 Vpp	2.4 Vpp	3 Vpp
Hi-Z source	100 Vpp	20 Vpp	20 Vpp	20 Vpp	20 Vpp	—	—	—	—
Bits/channel	—	—	16 kbit	4 kbit	16 kbit	16 kbit	64 kbit sequencing	64 kbit sequencing	Opt 002: 32-bit or 2 <sup>23</sup> -1 prbs
Channels	Single	Single	1 or 2	1 or 2	1 or 2	1 or 2	1 or 2	1 or 2	1 or 2
Internal channel add	—	—	Analog	Analog	Analog	—	EXOR	EXOR	—
Catalog page	438	434	434	437	434	434	434	434	439

<sup>1</sup> The 81110A is a form/function replacement for the 8110A. Great care has been taken to ensure compatibility so that the user may take immediate advantage of the 81110A's glitch-free range-changing and improved price and performance. However, for those customers who prefer to continue using the 8110A in existing test systems or products, the 8110A will remain available for an interim period. The 81110A (with one or two 81111A

output modules) is equivalent to the 8110A with the 81106A PLL module (plus one or two 81103A output modules).

<sup>2</sup> ±0.5% with self-calibration.

<sup>3</sup> Frequency > 170 kHz

<sup>4</sup> Applicable with internal channel addition only



### Accessories

#### 1. With BNC connectors

**15104A Pulse Adder/Splitter:** 50 ohm delta network, rise time 150 ps, 6 dB insertion loss, 2 W

**15116A Pulse Inverter:** 50 ohm pulse transformer, 5% droop (500 ns pulse), 0.3 dB insertion loss, 0.75 W

**15115A Splitter-Inverter:** 50 ohm delta network with pulse transformer in one output. Output skew: 1 ns, other specs as 15104A/15116A.

#### 2. With SMA connectors

**11667B Pulse Adder/Splitter:** 50 ohm series network, 26.5 GHz bandwidth, 6 dB insertion loss, 0.5  $\Omega$

### Transition Time Converters:

These components are for use when a very smooth pulse is needed, or when the stimulus is too fast for the DUT (as evidenced by excessive cross-talk, ringing, etc.). The converters use a patented absorption technique for minimum reflection and to allow cascading.

Model	Output Transition
15435A	150 ps
15432B	250 ps
15433B	500 ps
15434B	1 ns
15438A	2 ns

11667B  
151xx  
Series  
154xx  
Series

## Pulse Parameter Definitions of Terms Used in Instrument Specifications

**Time Reference Point:** Median (50% amplitude point on pulse edge).

**Pulse Period:** The time interval between the leading edge medians of consecutive trigger output pulses.

**Trigger Delay:** Interval between trigger point of input signal and the trigger output pulse's leading-edge median. Applies in trigger, external width, gate and burst modes.

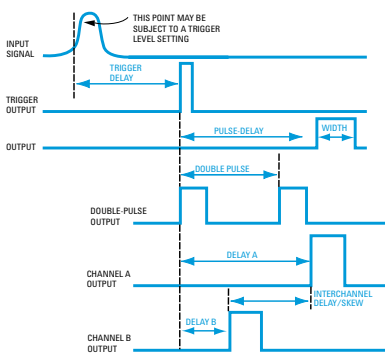

**Pulse Delay:** Interval between leading-edge medians of trigger-output pulse and output pulse.

**Double-Pulse:** Interval between leading-edge medians of the double-pulse.

**Interchannel Delay/Skew:** Interval between corresponding leading-edge medians.

**Pulsewidth:** Interval between leading and trailing-edge medians.

### Additional Information for Pulse Generators with Variable Transition Times

**Pulsewidth:** The specified and displayed value are those which are obtained with the fastest edges, essentially equal to the interval from the start of the leading edge to the start of the trailing edge.

By designing the pulse edges so that they turn about their start points, the interval from leading-edge start to the trailing-edge start stays unchanged\* when transition times are varied. This is more convenient for programming, and the width display is easy to interpret.

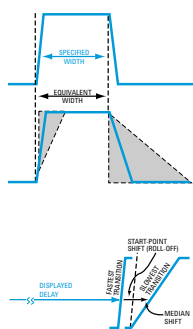

\* In practice, start points may shift with changes in transition time.

**Delay:** The specified and displayed values are those obtained with the fastest leading edge. For a slower edge, the actual delay exceeds the displayed delay by the combined shift of the start point and the median.

**Transition Time:** Interval between the 10% and 90% amplitude points on the leading/trailing edge.

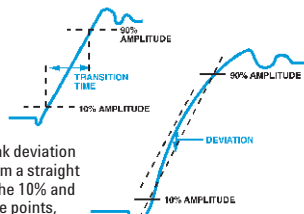

**Linearity:** Peak deviation of an edge from a straight line through the 10% and 90% amplitude points, expressed as a percentage of pulse amplitude.

**Jitter:** Short-term instability of one edge relative to a reference edge. Usually specified as an rms value, which is one standard deviation or "sigma". If the distribution is assumed to be Gaussian, six sigma represents 99.74% of the peak-to-peak jitter.

The reference edge for the period jitter is the previous leading edge, whereas the reference edge for the delay jitter is the leading edge of the trigger output. Width jitter is the stability of the trailing edge with regard to the leading edge.

**Stability:** Long-term average instability over a specific time, for example, an hour, or a year. The jitter is excluded.

**Pulse Amplitude:** Pulse output is specified as pulse top and pulse base (usually referred to as high level and low level), or as peak-to-peak amplitude and median offset. A "window" specification shows the limits within which the pulse can be positioned.

### Preshoot, Overshoot, Ringing:

Preshoot and overshoot are peak distortions preceding/following an edge. Ringing is the positive-peak and negative-peak distortion, excluding overshoot, on pulse top or base. A combined preshoot overshoot, ringing specification of e.g.,  $\pm 5\%$  implies:

- Overshoot/undershoot  $< 5\%$
- Largest pulse top oscillation  $< \pm 5\%$  of pulse amplitude

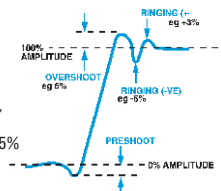
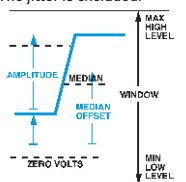

**Setting Time:** Time taken for pulse levels to settle within a level specification, measured from a 90% point on the leading edge.

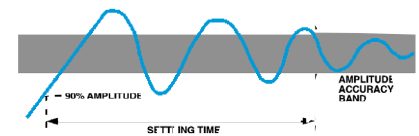

**Duty Cycle:** Percentage ratio of pulsewidth to period. In pulse/function generators, this term is also used to define sine and triangle symmetry. Note that in pulse generators, this is a secondary parameter derived from the period and width settings. The duty cycle achieved is therefore subject to width and period accuracies.

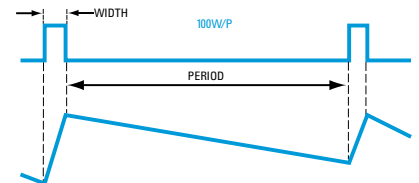

**Output Impedance/Resistance:** Effective pulse source impedance/dc resistance.

**Reflection Coefficient:** Reflection at the pulse generator output expressed as a percentage of the incident pulse amplitude. (Test pulse edges correspond to the generator's fastest transitions.)

**Repeatability:** When an instrument operates under the same environmental conditions and with the same settings, the value of a parameter will lie within a band inside the accuracy window. Repeatability defines the width of this band.

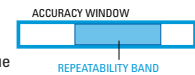

### GPIO Programming Times

**Listen Time:** The time an instrument occupies the bus to receive and verify a message. The NRFD signal is active during this period.

**Settling Time:** The time taken by the instrument to execute an GPIO message and for the output to settle within the accuracy specification. NRFD inactive.

**Execution Time:** The sum of Listen Time and Settling Time.

**Talk Time:** The time an instrument occupies the bus to output a specified string. Output data is typically instrument error status, or current or stored parameters.

For more information, visit our web site:  
[http://www.agilent.com/find/pulse\\_generator](http://www.agilent.com/find/pulse_generator)

## Applications

Typical application areas are:

- clock distribution
- disk drive testing
- general-purpose logic testing
- laser/optoelectronic testing
- LCD-display testing
- memory/flash memory testing

- Mixed signal/A/D-, D/A converter testing
- Physical research
- Radar/microwave testing
- Transmission test
- Trigger Source for system test

If you would like to learn more about these applications or customer case studies, please refer to the application section under [www.agilent.com/find/dvt](http://www.agilent.com/find/dvt)

## 81100 Family of Pulse/Pattern Generators (50 MHz – 660 MHz/1.32 Gb/s)

81101A  
81104A  
81110A  
81130A

- Synchronizable from an external clock (fixed and variable delay)
- 2 ns variable transitions up to 10 Vpp (20 Vpp) into 50 Ω
- Fast transitions up to 500 ps (ECL)
- 2 ps timing resolution
- 0.01% frequency accuracy
- Dropout- and glitch-free change of any timing parameters
- Pulse, burst, pattern (data) modes, data sequencing
- Analog or digital channel addition
- 1 or 2 channels
- 100% SW compatibility for all 4 models



81130A Pulse/Pattern Generator

### Agilent 81100 Family



The Agilent 81100 Family of Pulse/Data Generators uses the same operating principle throughout (front-panel and programming), and is compatible with the well-established 8110A to protect current and future investments. Growing with future needs is easy as the 81110A is a true superset of the 81104A and 81101A.

### Signals for Testing Digital Designs and Components

The 81100 Family generates all standard pulses, multi-level waveforms, digital patterns and data needed to test the current logic technologies (CMOS, TTL, LVDS, ECL, etc.) up to 660 MHz/1.32 Gbit/s. Continuous operation is enabled through the dropout- and glitch-free change of any timing parameters (e.g. to measure a PLL's pull-in/hold range) for all models except the 81130A.

### Smooth Integration Into Automated Test Systems

Accessories and the 81101A's and 81104A's 100% upward compatibility to the 81110A permit growth based on future needs through the physical exchange of instruments.

Please see our new VXI based C-size Pulse Generators. They are available in 165 MHz as well as in 330 MHz max. frequency range. Please refer to page 436 or visit us: [www.agilent.com/find/vxi](http://www.agilent.com/find/vxi)

### Specifications

50 Ω load, 0°C and 55°C  
Please refer to the tables overleaf.

**Channel Addition** (with two 81105A and 81111A output channels): Simulates digital signals with interference pulses, or 3 or 4 level communication signals. When channel 2 is added internally to channel 1, channel 2 is disabled. 48/500 Ω source selectable.

**Logic Channel Addition:** Both the 81131A and 81132A output channels add channels logically (EXOR) to the 81130A on channel 2. All specifications remain the same as for one channel.

### General

**Operating Temperature:** 0° C to +55° C

**Storage Temperature:** -40° C to +70° C

**Humidity:** 95% r.h. up to 40° C ambient temperature

**EMC:** conforms to EN50082-1, EN 55011, Class A

**Noise Emission:** 5.7 bel typical

**Battery:** Lithium CR2477-N

**Safety:** IEC1010, CSA1010

**Power Requirements:** 100-240 Vac ±10%, 50-60 Hz, 100-120 Vac ±10%, 400 Hz

**Power Consumption:** 300 VA max.

**Max. Dimensions:** 89 mm H x 426 mm W x 521 mm D (3.56 in x 17.04 in x 20.84 in)

**Weight Net:** 9.2 kg (20.24 lb)

**Weight Shipping:** 13.8 kg (30.36 lb)

**Recalibration Period:** 1 year recommended

**Warranty:** 3 years standard

### User Interface/Remote Control

**Non-volatile Memory:** Current setting is saved on power-down. Up to nine user settings and one fixed default setting can be stored in the instrument memory

**Memory Card:** 99 settings can be stored on a 1MB PCMCIA card (MS-DOS)

**Remote Control:** Operates according to IEEE standard 488.2, 1987 and SCPI 1992.0 with the function codes SH1, AH1, T6, L4, SR1, RL1, PP0, DC1, DT1, C0.

### Key Literature

Agilent Family of Pulse/Pattern Generators, Color Brochure, p/n 5980-0489E  
Agilent 81100 Family of Pulse/Pattern Generators, Technical Specifications, p/n 5980-1215E

### Ordering Information

The minimum configuration for a working instrument consists of a mainframe and one output module (except for the 81101A which is supplied with one module). A second output module may be added later, but must be of the same model number as the first.

The English Quick Start Guide (811xx-91010)<sup>1</sup> and Reference Guide (811xx-91011)<sup>1</sup> is supplied with each mainframe for all configurations. A memory card is not included.

**81101A** 50 MHz 1 channel Pulse Generator

**81104A** 80 MHz Pulse/Pattern Generator Mainframe

**81105A** 80 MHz, 10 V Output Channel  
(one or two channels must be added to the 81104A)

**81110A** 165/330 MHz Pulse/Pattern Generator Mainframe

**81111A** 165 MHz, 10 V Output Channel  
(one or two channels must be added to the 81110A)

**81112A** 330 MHz, 3.8 V Output Channel  
(one or two channels must be added to the 81110A)

**81130A** 400/660 MHz/1.32 Gbit/s Pulse/Data Generator Mainframe

**81131A** 400 MHz, 3.8 V Output Channel  
(one or two channels must be added to the 81130A)

**81132A** 660 MHz/1.32 Gbit/s, 2.5 V Output Channel  
(one or two channels must be added to the 81130A)

**The following accessories are available for each mainframe.**

**Opt 1CP** Rack Mount and Handle Kit (5063-9219)

**Opt 1CM** Rack Mount Kit (5063-9212)

**Opt 1CN** Handle Kit (5063-9226)

**Opt 1CR** Rack Slide Kit (1494-0059)

**Opt UFJ** 1MB SRAM Memory Card (0950-3380)

**Opt UN2** Rear (instead of front) Panel Connectors

**HP 15104A** Pulse Adder/Splitter

**Quick Start Guide Language Options**

**Opt ABF** French Guide (811xx-91210)<sup>1</sup>

**Opt ABJ** Japanese Guide (811xx-91510)<sup>1</sup>

**Opt AB0** Taiwan Chinese Guide (811xx-91610)<sup>1</sup>

**Opt AB1** Korean Guide (811xx-91710)<sup>1</sup>

**Opt AB2** Chinese Guide (811xx-91810)<sup>1</sup>

**Additional Documentation Options**

**Opt 0BW** Service Documentation (811xx-91021)<sup>1</sup>

<sup>1</sup> xx is used to denote that the product is available to order for each mainframe. Please substitute xx for 01, 04, 10, 30 (the last two digits of the relevant mainframe) when ordering.

Mainframe Output Channel	81101A Included	81104A 81105A	81110A 81111A	81110A 81112A	81130A 81131A	81130A 81132A
<b>Timing<sup>1</sup></b>						
<b>Frequency Range</b> 1k $\Omega$ Source <sup>2</sup>	1 mHz to 50 MHz Up to 50 MHz typ.	1 mHz to 80 MHz Up to 50 MHz typ.	1 mHz to 165 MHz Up to 60 MHz typ.	1 mHz to 330 MHz –	1 Hz to 400 MHz –	1 Hz to 660 MHz –
<b>Max. Data Rate</b>	–	160 Mbit/s	330 Mbit/s	660 Mbit/s	800 Mbit/s <sup>7</sup>	1.32 Gbit/s <sup>7</sup>
<b>Timing Resolution</b>	3.5 digits, 5 ps best case	3.5 digits, 5 ps best case	3.5 digits, 5 ps best case	3.5 digits, 5 ps best case	4 digits, 2 ps best case	4 digits, 2 ps best case
<b>Accuracy with PLL</b> (without PLL)	0.01% (5%) <sup>3</sup>	0.01% (5%) <sup>3</sup>	0.01% (0.5% typ. after self-cal., 3% without self-cal.) <sup>3</sup>	0.01% (0.5% typ. after self-cal., 3% without self-cal.) <sup>3</sup>	0.01% ( $\pm$ 100 ppm)	0.01% ( $\pm$ 100 ppm)
<b>RMS Jitter with PLL</b> (without PLL)	0.001% + 15 ps (0.01% + 15 ps) <sup>3</sup>	0.001% + 15 ps (0.01% + 15 ps) <sup>3</sup>	0.001% + 15 ps (0.01% + 15 ps) <sup>3</sup>	0.001% + 15 ps (0.01% + 15 ps) <sup>3</sup>	0.001% + 15 ps	0.001% + 15 ps
<b>Width Range</b>	10 ns to (period - 10 ns)	6.25 ns to (period - 6.25 ns)	3.03 ns to (period - 3.03 ns)	1.515 ns to (period - 1.515 ns)	1.25 ns to (period - 1.25 ns)	750 ps to (period - 750 ps)
<b>Accuracy</b>	$\pm$ 5% $\pm$ 500 ps	$\pm$ 5% $\pm$ 250 ps	After self-cal. $\pm$ 0.5% typ. $\pm$ 250 ps Without self-cal. $\pm$ 3% $\pm$ 250 ps	After self-cal. $\pm$ 0.5% typ. $\pm$ 250 ps Without self-cal. $\pm$ 3% $\pm$ 250 ps	> 170 kHz $\pm$ 0.01% $\pm$ 200 ps < 170 kHz $\pm$ 0.06%	> 170 kHz $\pm$ 0.01% $\pm$ 200 ps < 170 kHz $\pm$ 0.06%
<b>Deskew</b>	–	–	–	–	$\pm$ 25 ns	$\pm$ 25 ns
<b>Delay</b> (ext. in to out) (ext. in to trig. out)	28.5 ns fixed typ. 12 ns fixed typ.	27 ns fixed typ. 12 ns fixed typ.	26 ns fixed typ. 12 ns fixed typ.	22 ns fixed typ. 12 ns fixed typ.	47 ns typ. $\pm$ 1 period 15 ns $\pm$ 1 period	47 ns typ. $\pm$ 1 period 15 ns $\pm$ 1 period
<b>Additional Variable Delay Range Accuracy<sup>4</sup></b>	0 ns to (period - 20 ns) $\pm$ 5% $\pm$ 1 ns	0 ns to (period - 12.5 ns) $\pm$ 5% $\pm$ 0.5 ns	0 ns to (period - 3.03 ns) After self-cal. $\pm$ 0.5% typ. $\pm$ 0.5ns Without self-cal. $\pm$ 3% $\pm$ 0.5 ns	0 ns to (period - 3.03 ns) After self-cal. $\pm$ 0.5% typ. $\pm$ 0.5ns Without self-cal. $\pm$ 3% $\pm$ 0.5 ns	< 170 kHz $\pm$ 0.01% $\pm$ 100 ps > 170 kHz $\pm$ 0.035% of period	> 170 kHz $\pm$ 0.01% $\pm$ 100 ps < 170 kHz $\pm$ 0.035% of period
<b>Double Pulse Delay Range</b>	(Width + 10 ns) to (period - width – 10 ns)	(Width + 6.25 ns) to (period - width – 6.25 ns)	(Width + 3.03 ns) to (period - width – 3.03ns)	(Width + 1.5 ns) to (period - width – 1.5 ns)	–	–
<b>Transition Time Range</b> (10/90)	5 ns to 200 ms variable	3 ns to 200 ms variable	2 ns to 200 ms variable	0.8 ns or 1.6 ns selectable	0.8 ns or 1.6 ns selectable	500 ps typ. at 2.2V 250 ps typ. at ECL fixed
<b>At 1 k<math>\Omega</math> Source Imped.</b>	6 ns typ.	5 ns typ.	5 ns typ.	–	–	–
<b>Level/Pulse Performance<sup>5</sup></b>						
<b>Amplitude</b> 50 $\Omega$ into 50 $\Omega$ 1 k $\Omega$ into 50 $\Omega$	100 mVpp to 10.0 Vpp 200 mVpp to 20.0 Vpp	100 mVpp to 10.0 Vpp 200 mVpp to 20.0 Vpp	100 mVpp to 10.0 Vpp 200 mVpp to 20.0 Vpp	100 mVpp to 3.8 Vpp –	100 mVpp to 3.8 Vpp –	100 mVpp to 2.4 Vpp –
<b>Level Window</b> 1 k $\Omega$ into 50 $\Omega$	–10.0 V to +10.0 V –20.0 V to +20.0 V	–10.0 V to +10.0 V –20.0 V to +20.0 V	–10.0 V to +10.0 V –20.0 V to +20.0 V	–2.0V to +3.8 V –	–2.0V to +3.8 V –	–2.0 V to 3.0 V –
<b>Accuracy</b> 50 $\Omega$ into 50 $\Omega$ 1 k $\Omega$ into 50 $\Omega$	$\pm$ (3% + 75 mV) $\pm$ (5% + 150 mV) <sup>6</sup>	$\pm$ (3% + 75 mV) $\pm$ (5% + 150 mV) <sup>6</sup>	$\pm$ (1% + 50 mV) $\pm$ (1% + 100 mV) <sup>6</sup>	$\pm$ (2% + 50 mV) –	$\pm$ (2% + 50 mV) –	$\pm$ (5% + 50 mV) –
<b>Output Connectors</b>	BNC single-ended	BNC single-ended	BNC single-ended	BNC differential	SMA (f) 3.5 mm differential	SMA (f) 3.5 mm differential
<b>Source Impedance</b>	Selectable 50 $\Omega$ or 1 k $\Omega$	Selectable 50 $\Omega$ or 1 k $\Omega$	Selectable 50 $\Omega$ or 1 k $\Omega$	50 $\Omega$	50 $\Omega$	50 $\Omega$
<b>Accuracy</b>	Typ. $\pm$ 1%	Typ. $\pm$ 1%	Typ. $\pm$ 1%	Typ. $\pm$ 1%	Typ. $\pm$ 1%	Typ. $\pm$ 5%
<b>Max. External Voltage</b>	$\pm$ 24 V	$\pm$ 24 V	$\pm$ 24 V	–2.2 V to +5.5 V	–2.2 V to +5.5 V	–2 V to 4 V
<b>Short Circuit Current</b>	$\pm$ 400 mA max. (doubles for channel addition)	$\pm$ 400 mA max. (doubles for channel addition)	$\pm$ 400 mA max. (doubles for channel addition)	–84 mA to + 152 mA	84 mA to + 152 mA	–80 mA to 120 mA

<sup>1</sup> Measured at 50% amplitude at fastest transitions in continuous mode and with 50  $\Omega$  source impedance

<sup>2</sup> Source impedance is selectable from 50  $\Omega$  or 1k $\Omega$  for the 81105A, 81111A, and 81101A

<sup>3</sup> If the startable oscillator is used (PLL not active)

<sup>4</sup> Constant amplitude

<sup>5</sup> Level specifications are valid after a 5 ns (81112A, 81131A) or 30 ns (81111A, 81105A, 81132A) typical settling time

<sup>6</sup> Applies to pulses within a  $\pm$  19 V window

<sup>7</sup> Applicable only with internal channel addition

81101A  
81104A  
81110A  
81130A  
E8311A  
E8312A

Mainframe Output Channel (1 or 2)	81101A 1 included	81104A 81105A	81110A 81111A	81110A 81112A	81130A 81131A	81130A 81132A
<b>Dynamic Crosstalk</b>	< 0.1% typ.	< 0.1% typ.	< 0.1% typ.	< 0.1% typ.	< 0.1% typ.	< 0.1% typ.
<b>Baseline Noise</b>	10 mV RMS typ.	10 mV RMS typ.	10 mV RMS typ.	4 mV RMS typ.	4 mV RMS typ.	2 mV RMS typ.
<b>Overshoot/ Preshoot/Ringing</b>	± 5% of amplitude ± 20 mV	± 5% of amplitude ± 20 mV	± 5% of amplitude ± 20 mV	± 5% of amplitude ± 20 mV	± 5% of amplitude ± 50 mV	± 5% of amplitude ± 50 mV typ.
<b>Pattern/ Data Capabilities</b>	–	16 Kbit/channel and strobe output	16 Kbit/channel and strobe output	16 Kbit/channel and strobe output	64 Kbit/channel	64 Kbit/channel
<b>Sequencing</b>	–	–	–	–	Up to four segments, one loop (loop count 1 to 2 <sup>20</sup> times), one jump	Up to four segments, one loop (loop count 1 to 2 <sup>20</sup> times), one jump
<b>Format</b>	–	RZ, NRZ, DNRZ	RZ, NRZ, DNRZ	RZ, NRZ, DNRZ	R1, RZ, NRZ, DNRZ	R1, RZ, NRZ, DNRZ
<b>Burst</b>	Single or double pulses Burst count from 2 to 65536	Single or double pulses Burst count from 2 to 65536	Single or double pulses Burst count from 2 to 65536	Single or double pulses Burst count from 2 to 65536	Single pulses Burst count from 2 to 65536	Single pulses Burst count from 2 to 65536
<b>Trigger Modes</b>	Continuous Triggered (ext., int., man.) Gated (ext., int., man.) External width	Continuous Triggered (ext., int., man.) Gated (ext., int., man.) External width	Continuous Triggered (ext., int., man.) Gated (ext., int., man.) External width	Continuous Triggered (ext., int., man.) Gated (ext., int., man.) External width	Continuous Gated (ext. or man.), Start(ext. or man.)	Continuous, Gated (ext. or man.), Start(ext. or man.)
<b>Inputs</b>	PLL Ref. In, Clock In, Ext.In	PLL Ref. In, Clock In, Ext.In	PLL Ref. In, Clock In, Ext.In	PLL Ref. In, Clock In, Ext.In	PLL Ref. In, Clock In, Ext.In	PLL Ref. In, Clock In, Ext.In
<b>Load Compensation</b>	Actual load value can be entered to display actual outputs	Actual load value can be entered to display actual outputs	Actual load value can be entered to display actual outputs	–	–	–
<b>Additional Outputs</b>	Trigger out, strobe out	Trigger out, strobe out (16 Kbit user-defined pattern)	Trigger out, strobe out (16 Kbit user-defined pattern)	Trigger out, strobe out (16 Kbit user-defined pattern)	Trigger out	Trigger out
<b>Limits</b>	Programmable high and low levels to protect the device-under-test	Programmable high and low levels to protect the device-under-test	Programmable high and low levels to protect the device-under-test	Programmable high and low levels to protect the device-under-test	Programmable high and low levels to protect the device-under-test	Programmable high and low levels to protect the device-under-test
<b>Channel Addition</b>	–	Analog	Analog	–	EXOR	EXOR

Analog Channel Addition	81104A with Two Output Modules (81105A)	81110A with Two Output Modules (81111A)
<b>Amplitude 50 Ω into 1 kΩ 1 kΩ into 50 Ω</b>	100 mVpp to 20.0 Vpp 200 mVpp to 20.0 Vpp	100 mVpp to 20.0 Vpp 200 mVpp to 20.0 Vpp
<b>Source Impedance</b>	Selectable from 50 Ω or 1 kΩ	Selectable from 50 Ω or 1 kΩ
<b>Level Window 50 Ω into 1 kΩ 1 kΩ into 50 Ω</b>	–20.0 V to +20.0 V –20.0 V to +20.0 V	–20.0 V to +20.0 V –20.0 V to +20.0 V
<b>Max. Frequency 50 Ω Channel 1 kΩ Channel</b>	60 MHz typ. 15 MHz typ.	60 MHz typ. 15 MHz typ.
<b>Min. Transitions 50 Ω Channel 1 kΩ Channel</b>	2.5 ns typ. (channel one), 5 ns typ. (channel two) 20 ns typ. on both channels	2 ns typ. (channel one), 5 ns typ. (channel two) 20 ns typ. on both channels

### The New Versatile VXI Pulse/Pattern Generators NEW

The Agilent E8312A and E8311A VXI Pulse/Pattern Generators derive from the 81100 family. They are the functional compatible equivalents (programming and features) to the 81110A in a VXI C-1 mechanical format. The E8311A has a frequency range of up to 165 MHz and the E8312A up to 330 MHz. Both generators feature two output channels, 16 kbit pattern capability and high frequency accuracy (please see VXI table on page 96.) The modules are shipped with VXI plug&play drivers.

Please refer to the technical data sheet (5968-5814E) for detailed specifications or the VXI Catalog, or visit our web sites: [www.agilent.com/find/dvt](http://www.agilent.com/find/dvt) or [www.agilent.com/find/vxi](http://www.agilent.com/find/vxi)



New E8311A/12A VXI C-1 Pulse/Pattern Generators



- synchronizable from an external clock (fixed and variable delay)
- 10 ps resolution
- 2 ns variable transitions
- 20 V into 50 Ω

- Pulse, burst and data modes
- 3 and 4 level signals
- Configurable
- Master/slave capability

8110A



8110A and two 81103As

### 8110A Brief Specifications, 50 Ω load, 0° C to 55° C



#### 8110A Mainframe

**Frequency:** 1.00 Hz to 150 MHz (**Period:** 6.65 ns to 999 ms)  
**Modes:** Continuous/externally-triggered/externally-gated sequences of pulses, double-pulses, bursts, and patterns. Also external width  
**Burst Length:** 2 to 65536 pulses or double-pulses  
**Strobe Channel:** 2 to 4096 bits, freely programmable, NRZ, TTL/ECL, 50 Ω typical

#### 81106A PLL/Ext. Clock Module

**Frequency:** 1.000 MHz to 150.0 MHz (**Period:** 6.65 ns to 999.0 seconds)  
**Clock Modes:**  
**Int. Clock:** With int. or ext. references (as period source or trigger for bursts and patterns)  
**Ext. Clock:** For synchronization to a system clock or for master/slave operation

#### 81103A Channel Module

**Timing**  
**Delay:** 0.00 ns to 998 ms or **Double-Pulse:** 6.65 ns to 998 ms  
**Width:** 3.30 ns to 998 ms  
**Transitions** (10 to 90% amplitude): 2.00 ns to 200 ms  
**Accuracy:** 10% + 200 ps  
**Overshoot, Ringing:** 5% + 20 mV

#### Output Parameters (into 50 Ω load)

	50 Ω source	1 kΩ source
Amplitude, p-p	100 mV to 10.0 V	200 mV to 20.0 V
High level	-9.90 to +10.0 V	-18.8 to +19.0 V
Low level	-10.0 to +9.90 V	-19.0 to +18.8 V

Also programmable as current ±4.00 to ±400 mA.  
 Limits: programmable to suit and protect device.

**Source Resistance:** 50 Ω/1 kΩ, selectable  
**Load Resistance:** Values 0.1 Ω to 999 kΩ can be entered for direct reading display of output level  
**Modes:** Normal/complement, on/off  
**Channel Addition** (with two 81103A output channels): Simulates digital signals with interference pulses, or 3 or 4 level communications signals. 48/500 Ω source selectable  
**Pattern Capabilities:** 2 to 4096 bits. Edit capabilities include prbs 2<sup>n</sup>-1, where n is selectable from 7 to 12. Value 12 is CCITT 0.151-compatible  
**Format:** RZ (width and delay programmable), DNRZ (delay programmable)

#### 81107A Two Channel Deskew Module

Compensates for unequal propagation times in the test setup, or for slave propagation delay in master/slave setups.  
**Delay** (each channel): 0.00 to 28.00 ns + typ. 6.5 ns. Independent of period

#### General

**GPIO Capability**  
**Conformity:** IEEE-488.2, 1987, SCPI 1992.0  
**Function Code:** SH1, AH1, T6, L4, SR1, RL1, PP0, DC1, DT1, CO  
**Storage of Instrument Settings:** One power-down, one default setting and nine user locations. Additionally, 40 settings can be stored on the 8110A Option UFH memory card  
**Environmental**  
**Temperature:** 0° to 55° C operating, -40° to 70° C storage  
**Humidity:** 95% RH at 0° to 40° C  
**Power:** 100 to 240 V ac ± 10%, 50 to 60 Hz; 100 to 120 V ac ± 10%, 50 to 60/400 to 440 Hz  
**Consumption:** 300 VA (max. configuration)  
**EMC Conformity:** CISPR 11, A; EN55011, A; EN50082-1  
**Size:** 89 mm H x 426 mm W x 445 mm D (3.3 in x 17 in x 17.5 in)  
**Weight:** Net, 9.2 kg (20.24 lbs); shipping, 20.2 kg (44.44 lbs)  
**Recal. Period:** 1 year recommended  
**Warranty:** 3 years

#### Key Literature

Agilent Family of Pulse/Pattern Generators, color brochure, p/n 5980-0489E  
 8110A 150 MHz Pulse Generator, technical specifications, p/n 5980-1212E

For more information, visit our web site:  
<http://www.agilent.com/find/dvt>

#### Ordering Information

**8110A Mainframe** (includes English operating and programming manual 08110-91012).  
**Always order at least one 81103A with each 8110A.**  
 A second 81103A or an 81106A or 81107A—in any combination—can be ordered at the same time or fitted retrospectively.

- 81103A** Output Module
- 81106A** PLL/Ext. Clock Module
- 81107A** Deskew Module

#### 8110A Options

- Opt OB2** Additional Manual 08110-91012
- Opt UFH** 128 kB SRAM Memory Card
- Opt UK6** Commercial Cal. Certificate
- Opt UN2** Rear (instead of front) Panel Connectors
- Opt 1CN** Front Handle Kit (5062-3988)
- Opt 1CP** Rack Mount/Handle Kit (5062-3975)
- Opt 1CM** Rack Mount Kit (5062-3974)
- Opt 1CR** Rack Slide Kit (1494-0060)
- Opt 1BP** MIL-45662A Cal with Test Data
- Opt OBV** Service Manual, Component Level
- Opt OBW** Service Manual, Assembly Level
- Opt 503** Front and Rear Panel Connectors

8114A

- 100 V, 2 A pulses into 50 Ω
- 7 ns transitions (50 Ω into 50 Ω)
- Counted burst and external width
- SCPI programming commands
- Variable baseline ± 25 V (Option)
- Inhibit Input



### 8114A 100 V, 2 A Pulse Generator



#### Tests High Power Devices Reliably

The Agilent 8114A programmable pulse generator delivers fast-transition 100 V pulses into 50 Ω loads at rates of up to 15 MHz. In addition to simulating transients and glitches, it is well-equipped to characterize and test devices requiring high voltage or current pulses, such as flash memories, power MOS devices, IR/laser diodes and radar devices.

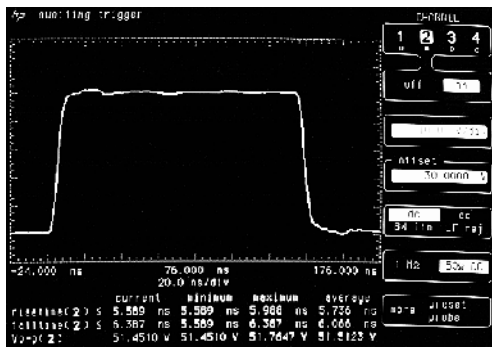

Typical 2 A pulse into 50 Ω for IR-diode test

#### Protects Your Device

The 8114A gives you fast, clean, and reliable pulses without risking damage to the device-under-test. You can also set voltage, current, and duty cycle limits to prevent accidental damage, and use an external TTL control signal at the Inhibit Input to inhibit/enable the pulse output.

#### Integrates Easily into Test Systems

SCPI programming commands for GPIB control and optional rear-panel connectors make the 8114A ideal for automated test systems. In addition, the Variable Baseline option allows a dc voltage of up to ± 25 V to be added to the pulse baseline, making an additional dc power supply unnecessary. The 8114A output is protected against excessive power dissipation.

#### Specifications

- Output:** 50 Ω into 50 Ω
- Amplitude:** 1.00 Vp-p to 50.0 Vp-p, 20.0 mA-p to 1.00 A-p (doubles when Hi-Z source selected)
- Resolution:** 3 digits, best case 10 mV
- Accuracy:** ± 1% of amplitude ± 0.5% baseline ± 100 mV
- Baseline:** 0 V ± 100 mV ± 0.5% of amplitude
- Variable Baseline Option 001:** -25 V to + 25 V, 50 Ω source impedance only
- Accuracy:** ± 1/± 100 mV ± 0.5% of amplitude
- Polarity:** Positive or negative baseline selectable
- Source Impedance:** High impedance or 50 Ω selectable
- Max. Short Circuit Current:** 2 A

#### Pulse Performance

- Overshoot/Preshoot/Ringing:** < 5% of amplitude ± 100 mV
- Setting Time:** < 100 ns typical
- Transition Times (10/90% amplitude):** 50 Ω into 50 Ω: < 7 ns (amplitude > 5 V); High-Z into 50 Ω: < 12 ns

#### Timing Parameters

- Measured at 50% of amplitude with 50 Ω source impedance into 50 Ω load
- Period:** 66.7 ns to 999 ms (**Frequency:** 1.00 Hz to 15 MHz)
- Accuracy:** ± 5% ± 100 ps
- Resolution:** 3 digits best case 100 ps
- Width:** 10.0 ns to 150 ms
- Duty Cycle:** 0.1 % to 100% (maximum duty cycle limited for amplitude > 20 V, worst case 15%)
- Accuracy:** ± 5% ± 500 ps
- Resolution:** 3 digits best case 100 ps
- Delay:** 0.00 ns to 999 ms (maximum value = period - 4 ns)
- Accuracy:** ± 5% ± 1 ns
- Resolution:** 3 digits best case 100 ps
- Fixed Delay:** 42 ns (trigger output to output) typical
- Double Pulse:** (Delay and Double-Pulse are mutually exclusive) 20.0 ns to 999 ms, minimum period 133 ns
- Resolution:** 3 digits best case 100 ps

#### Inhibit Input

- External TTL signal inhibits the pulse output, holding the output signal at its baseline level.
- Edge Mode:** An active edge inhibits the pulse signal, reset from front panel or GPIB.
- Level Mode:** An active level inhibits the pulse signal, an inactive level enables the signal level.

#### Trigger Modes

- Continuous:** Continuous pulse train
- Triggered:** External Input transition or manual trigger key generates pulse, double-pulse or burst of pulses
- Gated:** Active level at External Input or manual trigger key enables pulses, double-pulses or burst of pulses
- External Width:** Width of signal at External Input determines pulsewidth (maximum amplitude 20 V, 50 Ω into 50 Ω)
- Burst:** Bursts of 2 to 65536 pulse periods can be programmed

#### General

- Operating Temperature:** 0° C to +55° C
- Power:** 100 to 240 Vac ± 10%, 50 to 60 Hz; 500 VA max.
- Size:** 133 mm H x 426 mm W x 422 mm D (5.2 in x 16.8 in x 16.6 in)
- Weight:** Net, 14 kg (30.8 lbs); shipping, 17 kg (37.4 lbs)

#### Key Literature

Agilent Family of Pulse/Pattern Generators, color brochure, p/n 5980-0489E  
8114A 100v/2A Programmable Pulse Generator, technical specifications, p/n 5980-1213E

For more information, visit our web site: <http://www.agilent.com/find/dvt>

#### Ordering Information

- 8114A 100 V, 2 A Pulse Generator\***
  - Opt 001** Variable Baseline ±25 V
  - Opt OB2** Additional Users' Guide
  - Opt OBV** Service Guide, Component Level
  - Opt OBW** Service Guide
  - Opt UFH** 128 kB SRAM Memory Card
  - Opt UK6** Commercial Cal. Certificate
  - Opt UN2** Rear (instead of front) Panel Connectors
  - Opt 1BP** MIL-45662A Cal. with Test Data
  - Opt 1CM** Rack Mount Kit
  - Opt 1CN** Front Handle Kit
  - Opt 1CP** Rack Mount/Handle Kit
  - Opt 1CR** Rack Slide Kit
  - Opt 503** Front and Rear Panel Connectors

\* Memory card not included.

- Transitions typically < 60 ps
- 1 ps resolution, 350 fs with GPIB
- Optional data and PRBS capabilities

- Jitter typically < 1 ps
- Optional second pulse channel
- Synchronization of up to three instruments

8133A



8133A Pulse Generator with Option 002

### 8133A 3 GHz Pulse Generator



When timing is critical, the ability to characterize a digital product begins and ends with accurate edge-placement of the test signal. The Agilent 8133A makes an outstanding contribution through high resolution, very low jitter and very fast, linear transitions.

These attributes are required in digital designs with clock rates from a few hundred MHz and upwards. Some examples are:

- Circuits for distributing clock signals of several hundred MHz. At these frequencies, parametric effects cause asymmetry so that designers need to test performance under conditions where the duty cycle is not 50%.
- Microprocessor boards—the faster the processor, the more acute the HF problems. At high frequencies, the effects cannot be fully emulated, and therefore measurements on hardware are essential.
- The same applies to fast chip-to-chip communication, especially in integrated designs where discovery of timing problems late in the design cycle can be disastrous.
- Datacom/Telecom chips where clock rates go from several hundred MHz to a few GHz.

The 8133A means more efficiency in manufacture as well as design because the tightly-toleranced test signal reduces the reject rate and avoids overspecification.

As mentioned, a fast edge contributes to placement accuracy. On the other hand, if the edge is too fast, measurements can be impaired through unnecessary ringing or reflections. For this reason, a range of transition time converters are available which match the requirements of today's faster technologies and provide signals with very level pulse top, and little or no overshoot.

When several channels must be stimulated at the same time in order to perform a measurement, multi-channel accessory kits allow two or three 8133As to be master/slaved for up to six channel operation.

To investigate pattern effects or to make rapid performance checks using the eye-pattern technique with the 54120 series oscilloscope, the 8133A can be fitted with a pulse/data channel in place of the second pulse channel. This supports 32 bit patterns and the CCITT 0.151 2<sup>23</sup>-1 prbs.

### 8133A Configuration Overview

Channel	Standard	Option 001 <sup>1</sup>	Option 002 <sup>1</sup>	Option 003 <sup>1</sup>
1	Pulse channel width or delay	Pulse channel width and delay	Pulse channel width and delay	Pulse channel width and delay
2	None	None	Data channel 32 bit or PRBS	Pulse channel width or delay

<sup>1</sup>Options are mutually exclusive.

### Brief Specifications

#### Timing

**Frequency:** 33.0 MHz to 3.000 GHz, 100 kHz resolution  
**Period:** 300 ps to 30.000 ns, 1 ps resolution  
**Accuracy:** ± 0.5%, ± 0.1% nominal

#### Pulse Channel(s)

#### Square Mode (50% duty cycle):

**Delay:** 0.000 to 10.000 ns (–5.000 to +15.000 ns in Channel 1 if Option 001, 002, or 003 used)

#### Pulse Mode:

**Delay:** No variation (–5.000 to +5.000 ns in Channel 1 if Option 001, 002, or 003 used)

**Width:** 150 ps to 10.000 ns (max.: period –150 ps)

**Duty Cycle:** 0.0 to 100.0%, 0 and 100% mean dc at outputs

#### Accuracy: Typically 30 ps

**Delay Drift Against Delay:** 50 ps

**Phase:** –360.0 to +360.0°, subject to delay limits

#### Outputs, Channels 1 and 2 and (Trigger Output)

**Amplitude:** 0.30 to 3.00 Vp-p (0.5 to 1.80 Vp-p)

**Level Window:** –2.00 to +4.00 V (–4.00 to +4.00 V)

**Outputs:** Differential outputs, invertible (single)

**Transition Times:** 10% to 90% of amplitude: < 100 ps, 60 ps nominal;

20% to 80% of amplitude: < 60 ps, 40 ps nominal (< 100 ps)

**EMC Conformity:** CISPR II, EN5501, EN50082-1

### Key Literature

Agilent Family of Pulse/Pattern Generators, color brochure, p/n 5980-0489E  
 8133A 3 GHz Pulse Generator, technical specifications, p/n 5980-1214E

For more information, visit our website:

<http://www.agilent.com/find/dvt>

### Ordering Information

#### 8133A Pulse Generator

**Opt 001** Delay Channel 1

**Opt 002** Pulse/Data Channel 2

**Opt 003** Pulse Channel 2

Note: Option 002 and Option 003 contain Option 001.

These options are mutually exclusive. Extended warranty options (see page 70) available on request.

**Opt OB2** Additional Users' Guide

**Opt OBV** Service Manual, Component Level

**Opt OBW** Service Manual, Assembly Level

**Opt UK6** Commercial Cal. Certificate

**Opt 1BP** MIL-45662A Cal. with Test Data

**Opt 1CM** Rackmount Kit

**Opt 1CN** Handle Kit

**Opt 1CP** Rackmount/Handle Kit

**Opt 1CR** Rack Slide Kit (requires Opt H01)

**Opt H01** Preparation for Rack Slides

#### Accessories

**1250-1462** Adapter SMA (m) to SMA (f)

**8120-4948** 50 Ω Coax Cable, SMA (m-m)

**8710-1582** Torque Wrench, 5 lb-in

**8493A** Coaxial Attenuator

**Opt 003** 3 dB

**Opt 006** 6 dB

**Opt 010** 10 dB

**Opt 020** 20 dB

**Opt 030** 30 dB

**11667B** Power Splitter

**15439A** Multi-channel Accessory Kit for two 8133As

**15435A** 150 ps Transition Time Converter

See page 458 for other transition time converters.

Indicates QuickShip availability.



E2925B  
E2926B  
E2928A  
E2929A  
E2940A

- Complete family of professional PCI/PCI-X system test equipment
- PCI/PCI-X test solutions for the entire design cycle
- 33/66 MHz PCI Exerciser and Analyzer
- 133 MHz PCI-X Exerciser and Analyzer
- Full 32/64 bit solutions including protocol check for 64-bit commands
- CompactPCI test solutions, including hot swap functionality

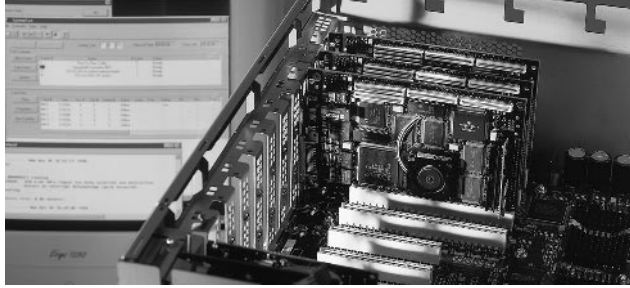

PCI Server during system validation with the Agilent E2928A

### PCI/PCI-X Series Exerciser & Analyzer

The Agilent E2920 PCI/PCI-X Series of Verification Tools is a family of test tools designed to provide an early and extensive insight into PCI/PCI-X-based designs, revealing and solving design problems sooner throughout the entire development process, from initial bring-up of devices and systems, through to system validation.

The tools supplied with the E2920 PCI/PCI-X Series not only help you get your new designs to market faster, but also give you the confidence of knowing your product will perform in any conceivable situation.

For more information visit our web site:  
[www.agilent.com/find/pci\\_overview](http://www.agilent.com/find/pci_overview)

### Evaluate: Getting Your Design Off to a Good Start

In the early stages of your PCI/PCI-X based prototype evaluation, you need to analyze the behavior of your system, device or firmware and detect the cause of any errors or problems as early as possible during the bring-up and debugging. The PCI/PCI-X Analyzer features a PCI/PCI-X state logic analyzer, real-time protocol and timing checkers, real-time performance measures and a PCI/PCI-X optimized trigger, giving you a fast overview of your system status.

PCI/PCI-X bus traffic from the state waveform level up to data transfer level can be captured and analyzed, allowing the observation of traffic at a level meaningful to the problem. The identification and triggering of protocol violations is possible at any time.

For more information visit our web site:  
[www.agilent.com/find/pci\\_evaluate](http://www.agilent.com/find/pci_evaluate)

### Optimize: Overcoming the First Hurdles

Optimizing a PCI or PCI-X design means applying your expertise to the analysis of traffic and of bus performance and then applying what you find to help improve your devices. The PCI/PCI-X Performance Optimizer is a powerful tool, which provides you with an in-depth real-time and post processing performance analysis, giving hints for performance optimization. The PCI/PCI-X Exerciser plays an active role in the analysis of complex PCI/PCI-X scenarios by letting you set up worst case traffic patterns quickly and allowing errors to be easily reproduced for deeper investigation. Identifying bottlenecks and true performance potential helps you optimize your design.

For more information visit our web site:  
[www.agilent.com/find/pci\\_optimize](http://www.agilent.com/find/pci_optimize)

### Validate: Ensuring Reliability in the Long Run

Validating your PCI/PCI-X device means ensuring its reliability in the long run. The E2920 PCI/PCI-X Series use the PCI/PCI-X bus as the "standard" interface to validate a system. Variable levels of background traffic can be generated and typical peripheral traffic patterns emulated to stress arbitration, memory controller, bridges and system interrupts. The System Validation Package (Opt 310) provides a set of tests for testing particular sub-systems. The C-Application

Programming Interface (C-API) available with the Protocol Permutator and Randomizer (PPR)(Opt 320) enables full range testing. Automatic protocol permutations within user-defined constraints, enable optimum test coverage of PCI/PCI-X behavior of a device or system, in the minimum amount of time.

For more information visit our web site:  
[www.agilent.com/find/pci\\_validate](http://www.agilent.com/find/pci_validate)

### System Description

The PCI/PCI-X Exerciser and Analyzer is delivered as a single, short card, which requires plugging into the system that needs to be tested. Plugging other PCI/PCI-X devices into the system-under-test enables these devices to also be tested.

The E2920 PCI/PCI-X Exerciser and Analyzer can either be externally controlled by a RS-232, a 4 MB fast host interface, USB (E2929A), or through the system-under-test via PCI/PCI-X.



Compact PCI Exerciser/Analyzer Card

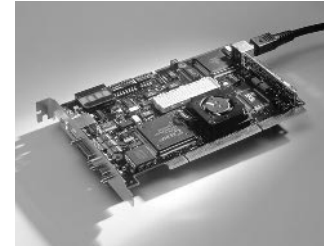

PCI-X Exerciser/Analyzer Card

### Key Literature

- E2920 Verification Tools, PCI/PCI-X Series, Color Brochure, p/n 5968-9494E
- E2925B, E2926B, Technical Specifications, p/n 5968-3501E
- E2928A, Technical Specifications, p/n 5968-3506E
- E2922A, Technical Specifications, p/n 5968-9577E
- E2929A, Technical Specifications, p/n 5968-8984E
- E2940A, Technical Specifications, p/n 5968-1915E
- E2976A, E2977A, Technical Overview, p/n 5968-3500E

For customer reference stories/application notes and latest ordering information, please visit our web site: [www.agilent.com/find/pci\\_overview](http://www.agilent.com/find/pci_overview)

### Software/Graphical User Interfaces

The **PCI/PCI-X Analyzer Graphical User Interface** is a comprehensive Windows 98/2000/NT graphical user interface for the PCI/PCI-X exerciser and analyzer's on-board logic analyzer. It allows the analysis of bus traffic quickly and easily:

- Easy setup of trigger sequences and storage qualification for the on-board PCI/PCI-X state logic analyzer
- Real-time PCI/PCI-X protocol checker
- State Waveform Lister displays waveform trace of all PCI/PCI-X signals, sideband I/O and internal bus state signals
- Bus Cycle Lister disassembles bus traffic at state level, with comprehensive error reporting including cross references to PCI/PCI-X specification
- Bus Transaction Lister summarizes bus transfer at address and data level

The **PCI/PCI-X Exerciser Graphical User Interface** (comes with #300) is a comprehensive Windows 98/2000/NT graphical user interface, which controls the PCI/PCI-X exerciser and analyzer's programmable PCI/PCI-X master and target:

- Configuration Space Editor to set up the configuration space
- Master Transaction Editor to set up master transactions and protocol behavior and requester/completer for PCI-X
- Target Attribute Editor to set up protocol behavior for the target
- Data Memory Editor to view/modify the on-board memory content

The **PCI/PCI-X Performance Optimizer** (comes with #200) is a comprehensive Windows 98/2000/NT graphical user interface using the exerciser and analyzer capabilities to help engineers optimize performance. It features:

- Performance analysis with real-time counters and in-depth post processing
- Hierarchical data representation for fast problem detection and in-depth root cause analysis with report generation



**PCI/PCI-X Exerciser and Analyzer Comparison Table**

	<b>E2940A</b>	<b>E2925B</b>	<b>E2926B</b>	<b>E2928A</b>	<b>E2929A</b>
<b>Data-path width</b>	32/64 bit	32 bit	32 bit	32/64 bit	32/64 bit
<b>Addressing</b>	32/64 bit DAC	32 bit	32 bit	32 bit/64 bit DAC	32 bit/64 bit DAC
<b>PCI clock range</b>	0...66 MHz Analyzer 0...33 MHz Exerciser	0...33 MHz	0...33 MHz	0...66 MHz	0...133 MHz
<b>State PCI logic analyzer trace memory</b>	64 K on-board/ 4 M (E2995A)	64 K on board/ 4 M (E2995A)	64 K on board/ 4 M (E2995A)	64 K on board/ 4 M (E2995A)	#100, 2M on board
<b>Mechanical</b>	Compact PCI card	PCI short card	PCI short card	PCI short card	PCI-X short card
<b>Fast back to back (master)</b>	Yes	Yes	Yes	No	n/a
<b>Target decode speed</b>	Fast/Medium/Slow	Fast/Medium/Slow	Fast/Medium/Slow	Fast <sup>1</sup> /Medium/Slow	Fast/Medium/Slow
<b>LOCK control</b>	Lock/Hide/Unlock	Lock/Hide/Unlock	Lock/Hide/Unlock	No lock control	No lock control
<b>Programmable clock delay between transactions</b>	0 to 2,000,000	0 to 2,000,000	0 to 2,000,000	0 to 2,000,000	1 to 65,536
<b>Real-time counter size</b>	64 bit	64 bit	64 bit	64 bit	64 bit
<b>Signal levels</b>	3.3/5 V	3.3/5 V	3.3/5 V	3.3/5 V	3.3 V
<b>Temperature range</b>	-40° C to 70° C	-40° C to 70° C	-40° C to 70° C	-40° C to 70° C	-40° C to 70° C
<b>Trigger I/O</b>	12	12	12	12	4
<b>Data memory</b>	512 KB	512 KB	512 KB	512 KB	1 MB
<b>Real-time checked protocol rules</b>	53	53	53	53	53
<b>Control interfaces</b>	RS 232, fast host interface, PCI	RS 232, fast host interface, PCI	RS 232, fast host interface, PCI	RS 232, fast host interface, PCI	RS 232, fast host interface, USB, PCI-X
<b>PCI compatibility</b>	PCI 2.1	PCI 2.1	PCI 2.1	PCI 2.1	PCI-X 1.0

<sup>1</sup> Fast, decode speed up to 66 MHz

- Numerable ready-to-go tests: data transfer rate, data efficiency, bus usage, retry rate

**The System Validation Package** (comes with #310), which is a ready-to-use software package running on Windows NT/2000 to perform system stress test during system validation. It automatically sets-up tests to stress to stress the computers data paths from:

- CPU and Exerciser to system memory
- Exerciser to system memory
- CPU to Exerciser memory space
- CPU to Exerciser I/O space
- Peer to peer traffic
- Master to target traffic

**C-API and PCI/PCI-X Protocol Permutator & Randomizer library** (comes with #320), which provides automatic PCI/PCI-X protocol permutations within user-programmed constraints. It features:

- Reduced and predictable test time, as use of the system CPU is not required
- PCI/PCI-X master and target support
- Comprehensive reports of performed protocol variations

NOTE: For specific product configurations, please refer to the data sheets listed on the previous page. Prices start at \$5,800.

**The following accessories are available for the E2920 Verification Tools, PCI/PCI-X Series:**

<b>Agilent Products</b>	<b>E2940A</b>	<b>E2925B</b>	<b>E2926B</b>	<b>E2928A</b>	<b>E2929A</b>
<b>E2991A</b> External Power Supply		X	X	X	X
<b>E2993A</b> External Agilent Logic Analyzer Adapter		X	X	X	
<b>FS2104</b> Future Plus Logic Analyzer Adapter					X
<b>E2994A</b> General Purpose Logic Analyzer Adapter		X	X	X	
<b>E2995A</b> 155 x 4M Trace Memory		X	X	X	
<b>E2996A</b> 155 x 4M Trace Memory	X				
<b>E2977A</b> System Test Library	X	X	X	X	X

In addition, the E2922A PCI-X Master Target Card is available for larger labs with multiple test benches.

E2925B  
E2926B  
E2928A  
E2929A  
E2940A

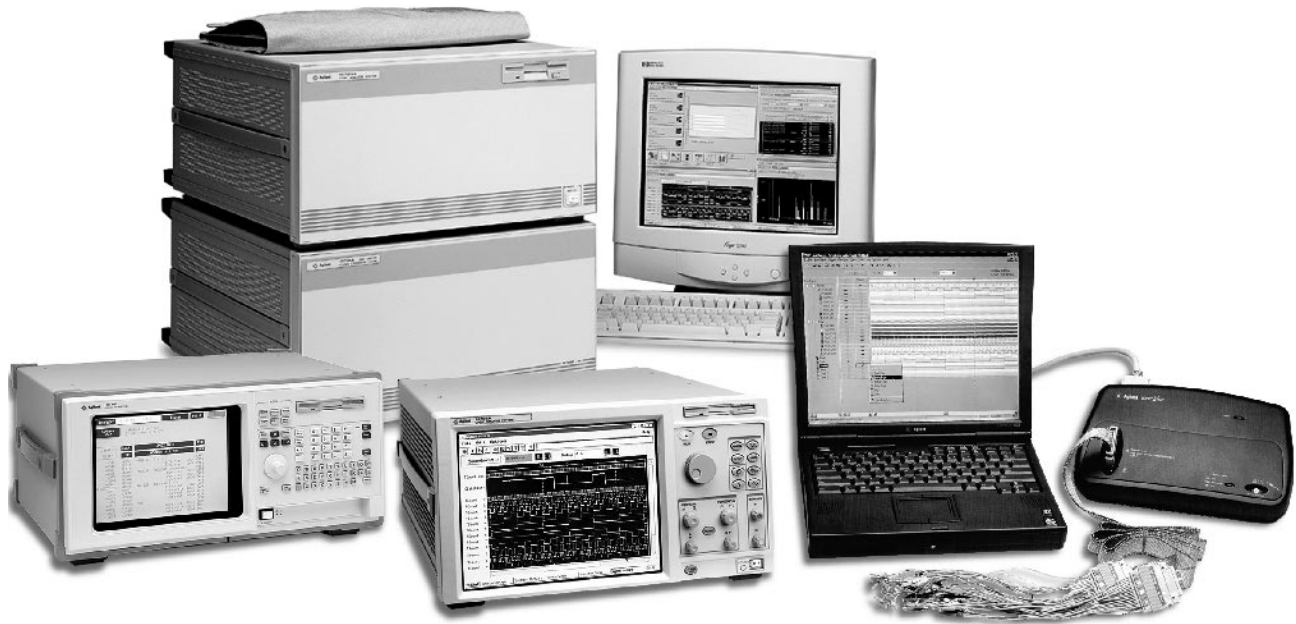

Agilent provides a broad range of digital system debug tools to help you solve your hardest problems the fastest way.

### Creating a Shorter Path from Problems to Insights to Answers

Your design team faces a difficult challenge to deliver quality products to the marketplace faster than your competitors. Part of that challenge is your ability to turn on early prototypes in order to characterize and debug hardware, design and test firmware and software, and perform system integration.

Design problems are getting harder to find and solve. Problems stretch across domains from analog signals to source code. When the prototype does not work as expected, you need debug tools that quickly provide you with reliable insight into your toughest problems.

By listening to thousands of designers like you, Agilent Technologies has developed a wide range of solutions to meet real-world debugging challenges, from 8-bit designs to 64-bit multiprocessor systems using the newest chips on the market.

### Solutions from Signals to Source

Agilent provides a wide variety of logic analyzers for general-purpose debugging at attractive price/performance points. From basic timing analysis to cross domain measurements and from PC-hosted to highly integrated self-contained units, Agilent offers the right logic analyzer to meet your application and budget.

The 16700 Series of scalable debug tools provide the capability to do hardware debug and rapidly integrate complex digital systems. You get the digital hardware debug capabilities and low intrusion factors of a logic analyzer, combined with the software-execution visibility and processor-execution control benefits of an emulator.

Agilent offers insight into hardware/software interaction, software performance and other system-wide behaviors that extend beyond the processor itself.

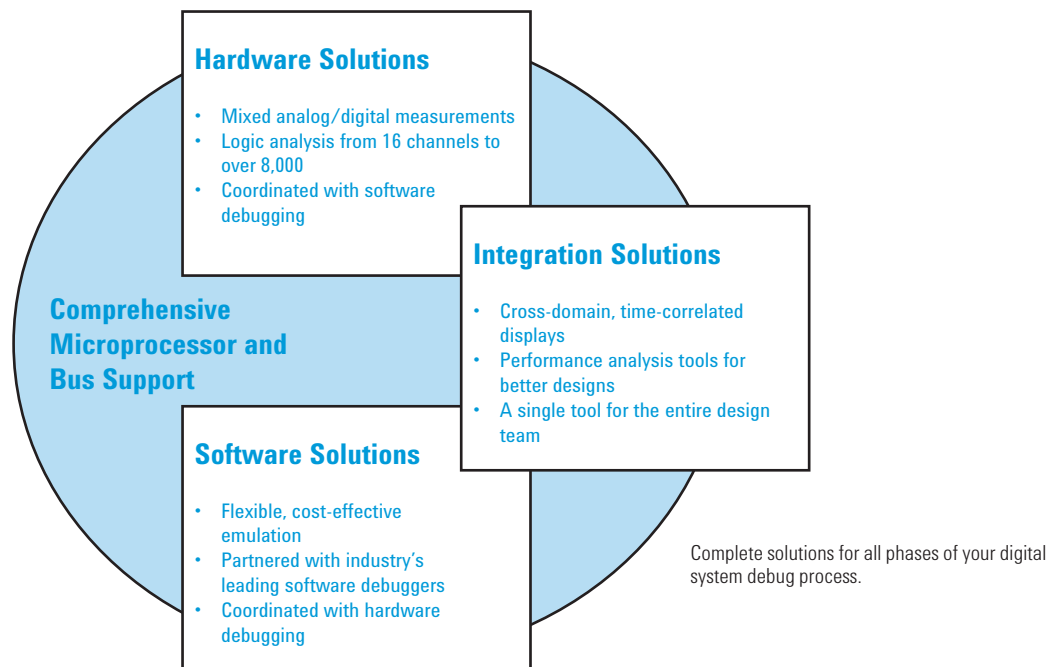

## Benchmark Logic Analyzers

### We've Made One Just Your Size

Matching the troubleshooting capabilities you need with the tool budget you have available can be a difficult task. That is why Agilent offers a wide variety of benchmark logic analyzers so you can choose the model that best matches your exact needs.

#### Selection Guide

<b>Model Number</b>	<b>54622D</b>			
Channels	16			
Application	General purpose timing analysis with integrated oscilloscope			
<b>Model Number</b>	<b>E9340A (LogicWave)</b>			
Channels	34			
Application	PC hosted state and timing analysis			
<b>Model Number</b>	<b>1670G</b>	<b>1671G</b>	<b>1672G</b>	<b>1673G</b>
Channels	136	102	68	34
Application	Full-featured logic analysis with deep memory, integrated oscilloscope or pattern generator			

Turn to pages 445 and 446 for the entire story.

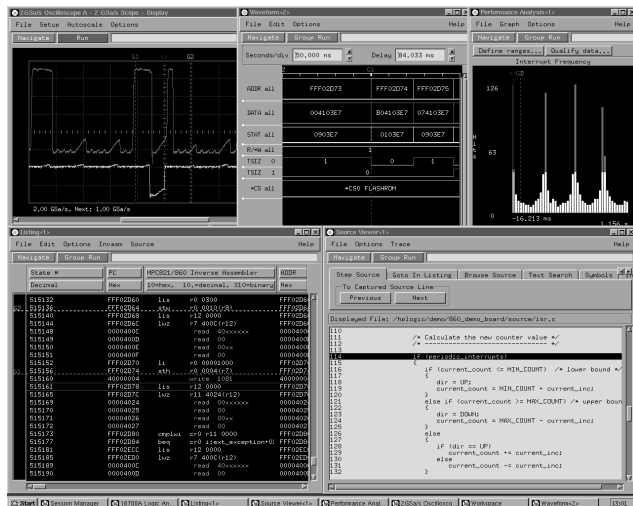

View system resources in multiple domains, all time-correlated.

## 16700 Series Logic Analysis Systems

The logic analysis systems offer a single solution for hardware, software and system debugging.

Hardware designers get the measurement power that made the 16500 logic analyzer the top seller for more than a decade, plus processor execution control, register access and other tools to explore software-dependent hardware problems such as interrupt handling.

Software designers get debugging and analysis tools that overcome the drawbacks of traditional emulation, while providing an easier way to solve hardware-dependent software problems that only a logic analyzer can uncover.

System designers get time-correlated views showing system activity from analog signals all the way to source code. The Agilent logic analysis systems' cross-domain displays minimize the mysteries of hardware-software interaction, helping the team track symptoms back to root causes quickly and confidently. See page 448 for complete details.

## Processor Support

Agilent's emulation technology keeps pace with today's most powerful processors, as well as gives you valuable insight into hardware/software interaction, and other system-wide behaviors that extend beyond the processor itself.

Agilent logic analysis systems can be customized to support your processor by adding one or more of the following components:

- Analysis probes provide a non-intrusive mechanical and electrical connection to your processor, giving you a complete picture of bus activity.
- Source correlation tool set provides a real-time trace linked to the high-level source language, time-correlated to activity captured by the logic analyzer's acquisition modules.
- Emulation module/probe provides control of program execution including fast code download, setting breakpoints and stepping, in addition to having the ability to modify memory and registers. The emulation module or emulation probe can be controlled by a high-level debugger or by Agilent's emulation control interface.
- Agilent's emulation control interface. If you are using the emulation module primarily for debugging hardware, control the emulation module using Agilent's emulation control interface. The interface gives you control over program execution including setting breakpoints and stepping, the ability to modify memory and registers, and memory disassembly.
- Debuggers purchased from vendors (see page 459). The debugger allows you to control the emulation module. This combination gives you the tools necessary to locate elusive software-dependent hardware bugs and hardware-dependent software bugs.

See page 455 for the further details.

## Start-Up Assistance

### The Fastest Way to Increase Productivity

Agilent Response Center Start-Up Assistance provides processor-specific start-up assistance to help your design team become productive quickly with your logic analysis and emulation solution. Agilent digital systems consultants provide a full day of training and productivity assistance at your site. You get help solving complex debug and target system problems specific to your system designs. And the one-day session can be geared to any experience level, so you get relevant information whether you're a veteran or beginner. To learn more about this and other Agilent productivity solutions, just turn to the Agilent Services and Support section in this catalog, or go online: [www.agilent.com/find/jumpstart](http://www.agilent.com/find/jumpstart)

## Ordering Information

**50629L** Processor Specific Consulting, One-Day Session

Intel  
Celeron  
Pentium  
Pentium II/III  
Motorola  
ARM

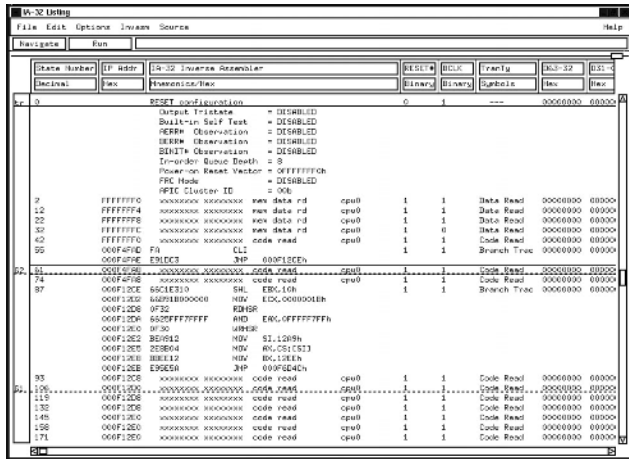

Inverse assembly listing for the Pentium processor.

Isolating the root cause of elusive system turn-on and compatibility problems requires that you track the interactions between the processor(s) and critical buses in the system. When tailored to your system requirements with processor and bus specific analysis probes and emulation modules, the 16700 Series logic analysis systems give you invaluable insight into system operation. Here are a few examples of Agilent's extensive analysis probe support.

### Intel Celeron, Pentium II, III, or Pentium System Debug

To capture the complete picture of your computer system's operation, it is necessary to track activity on multiple buses simultaneously. The 16700 series logic analysis systems allow you to time-correlate your display of data captured on multiple buses in your system. With the 16700 series logic analysis system, it is simple to display Celeron, Pentium II, III, or Pentium processor bus traffic in the same listing as PCI, ISA and APIC bus traffic. In addition, bus cycles on the Intel i960RP peripheral processor bus can be captured and viewed using an Agilent analysis probe. Since data captured on each bus in the system is time-correlated, it is easy to measure time delays across bus bridges in your system.

The Agilent inverse assembler displays code execution in familiar code mnemonics. The inverse assembler takes advantage of the Celeron, Pentium II, III, or Pentium processor's branch trace message (BTM) bus cycles. Branch trace messages are special bus cycles issued by the CPU (when enabled) that indicate the "from" and "to" addresses of a branch. By using BTMs, the inverse assembler can track code flow when cache is enabled.

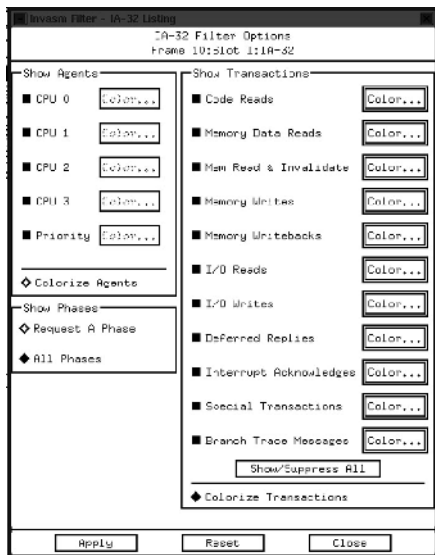

Inverse assembler options for Pentium processors.

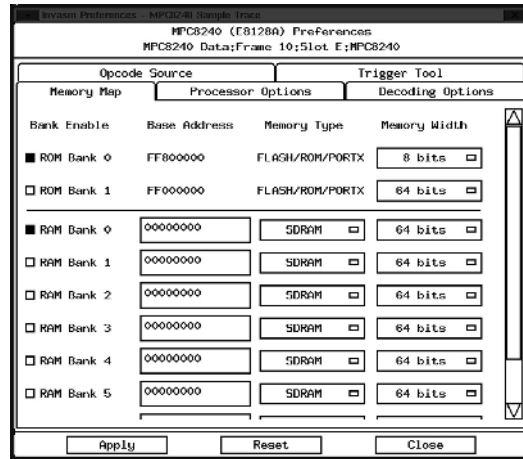

Inverse assembler configuration screen for MPC 82XX.

### Motorola MPC 82XX Series System Debug

Agilent's solutions for Motorola MPC 82XX microprocessors combine the powerful tools of emulation, code download, debugger connections, and logic analysis for a complete, scalable system debug environment.

Using an analysis probe in conjunction with an Agilent emulation probe or module, you can quickly configure the logic analyzer by labeling address, data and status signals for the MPC 82XX, as well as control program execution through single stepping, start/stop, run/break and set/modify breakpoints. You can also run code at full speed in the target.

Once the logic analyzer acquires the real-time trace, step through the trace at assembly-code level or source-code level. Locate the cause of a problem by time correlating this measurement to other system activity.

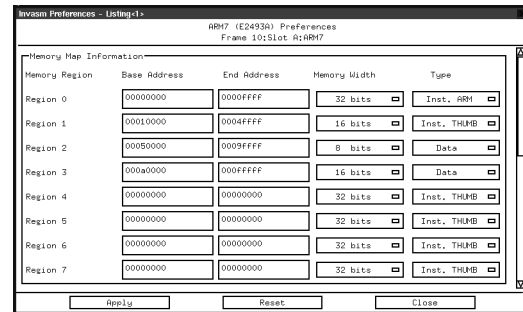

Inverse assembler configuration screen for ARM7.

### ARM7 and ARM9 System Debug

The new trace port analyzer provides realtime, non-intrusive execution and data trace for ARM 7 or ARM 9-based systems, which have cache memory or on-board program memory when the processor contains the ARM Embedded Trace Module. The trace port analyzer works in conjunction with an Agilent emulation probe/module and a third-party debugger to provide a complete emulation capability, including inverse assembly and source code correlation, at an affordable price. An emulation probe or module is available separately, and can be used in conjunction with industry-leading debuggers.

Where address, data and status lines of the ARM processor are available externally for connection to a logic analyzer, the Agilent inverse assembler provides ARM or THUMB mnemonics in the trace listing for easy correlation between captured data and target code. The inverse assembler can be used with the B4620B source correlation tool set. This allows time correlation of an acquired trace to source code.



- An affordable logic analyzer that is very user-friendly
- 100 MHz state, 250 MHz timing, 128K memory and 34 channels
- A well crafted Windows user interface provides efficient single window operation
- A compact, PC hosted form factor makes the product truly transportable, 29.1 cm H x 22.8 cm W x 6.3 cm D (11.5 in x 9 in x 2.5 in), 2.1kg (4.5 lb)
- An intuitive tool you won't have to relearn every time you use it
- Try it out for yourself by downloading the user interface: [www.agilent.com/find/LogicWave](http://www.agilent.com/find/LogicWave)

Laptop sold separately.



LogicWave logic analyzer (E9340A)

### New Users Find LogicWave Intuitive

Infrequent or first time users of logic analyzers will find the product intuitive. Problems that can take days to hunt down using just an oscilloscope can be found in hours with the help of an Agilent LogicWave.

### Experienced Users Find LogicWave Handy

Frequent users of logic analyzers will find the streamlined user interface a delight to use. Owners of an Agilent LogicWave logic analyzer won't have to wait until the big lab analyzer is free to make their basic measurements.

### Ease-of-Use Innovations Abound

We watched how engineers used logic analyzers and listened to their frustrations to develop some breakthrough ease-of-use innovations: "What You Draw Is What You Capture" (WYDIWYC) Timing Trigger, Zoom Box, Drag & Drop Labels, Expand/Collapse Buses, Group into Bus, Tool Tip Bus Values, Activity Indicators, Off-line Analysis and more. But don't take our word for it—try it out for yourself by downloading the user interface off of our web site.

### Affordable & Friendly Logic Analysis

The Agilent LogicWave logic analyzer provides impressive performance at our lowest price ever for a full-featured state and timing analyzer. An innovative user interface also makes this logic analyzer user-friendly.

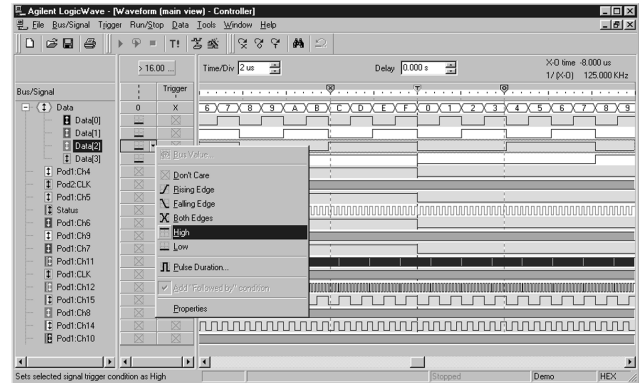

Innovative use of the familiar Windows user interface makes the logic analyzer easy to use. Commonly used features are available in a single window with less frequently used features accessed via a few dialog boxes

### Key Specifications and Characteristics for the LogicWave Logic Analyzer

<b>Model</b>	<b>E9340A</b>
<b>Channels</b>	34
<b>State Speed</b>	100 MHz
<b>Timing Speed</b>	250 MHz
<b>Memory Depth</b>	128K
<b>Triggering</b>	"What You Draw Is What You Capture" (WYDIWYC) Timing Trigger
<b>Probing</b>	Agilent Patented, 100 kΩ, 1.5 pF
<b>I/O Ports</b>	Enhanced Parallel, Trigger In/Out BNC
<b>User Interface</b>	Windows 95/98/NT, Pentium or Better, Desktop or Laptop. Runs as an application—no need for a dedicated PC. Fast update rates
<b>Dimensions</b>	29.1 cm H x 22.8 cm W x 6.3 cm D (11.5 in x 9 in x 2.5 in)
<b>Weight</b>	2.1 kg (4.5 lb)

### Key Literature

- LogicWave (E9340A) Technical Specifications, p/n 5968-5560E
- LogicWave Product CD (with fully functional user interface) p/n E5968-6655E

These items can also be downloaded via the internet at: [www.agilent.com/find/LogicWave](http://www.agilent.com/find/LogicWave)

### Ordering Information

- E9340A** Agilent LogicWave Logic Analyzer
- Opt 001** Quick Reference Card & Demo Board

E9340A

10

1670G  
1671G  
1672G  
1673G

- Tailor cost-effective solutions to match your specific application
- Simplify capture and analysis of complex events with up to 2M deep memory
- View analog and digital signals simultaneously with the optional two-channel, 500 MHz oscilloscope
- Stimulate circuits and simulate missing components with the optional pattern generator capability



### Get Personalized Power with a Logic Analyzer Built for Your Unique Needs

The Agilent 1670G Series logic analyzers offer cost-effective 150 MHz state analysis and timing analysis at speeds up to 500 MHz. The high-speed acquisition memory can be configured for depths up to 2M samples over as many as 136 acquisition channels. An optional 2-channel, 500 MHz oscilloscope or a 32-channel pattern generator capable of up to 200 MVector/s can be added to the unit to customize it for signal integrity or stimulus-response applications. Never before has so much measurement power been available in such an affordable package.

You'll make productive use of all the measurement power, too. A commonsense user interface helps you solve your design problems faster, and the ability to view processor mnemonics and waveforms simultaneously makes it easier to see cause/effect relationships in your system. Navigating through the user interface is made simple via a choice of either mouse or front-panel operation. An optional keyboard is also available. The color flat-panel display will help you find information quickly.

Graphical trigger macros assist in making powerful measurements. Trigger setups can be selected from a categorized list of trigger macros. Each macro is shown in a graphical form and has a written description. Macros can be chained together to form a custom trigger sequence.

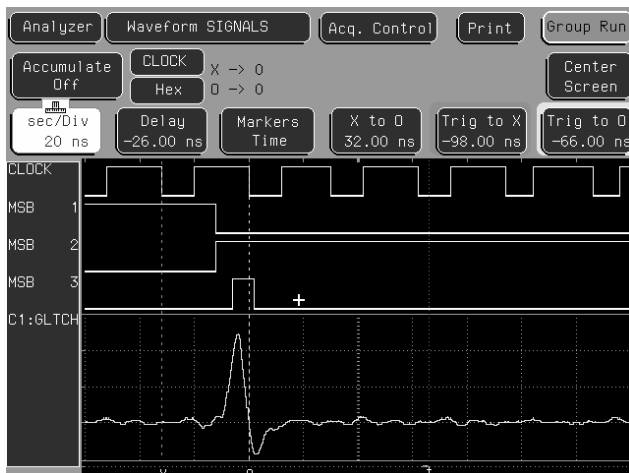

Optional built-in oscilloscope allows correlation of timing, state, and analog signals, to facilitate identification of glitches.

### An Excellent Toolset for Hardware Development

Some of the tougher hardware problems can be found only with the digital triggering capabilities of a logic analyzer and solved only with the analog resolution of an oscilloscope. That's why a built-in, 500 MHz, 2-GSa/s oscilloscope that can be triggered by the logic analyzer may be added to any model. Now, you can see what bus lines really look like at critical moments.

The optional pattern generator capability allows you to functionally test your digital design. You can stimulate the design under test and see how it responds to specific signals or clock speeds. You can also use the pattern generator to substitute for missing subsystems. The data captured with the state or timing analyzer can then be used to verify correct operation.

### Get the Whole Picture with Deep Memory

Deep memory can be a valuable logic analyzer feature for solving difficult or poorly understood problems in embedded micro-processor systems. It saves time you might otherwise spend taking multiple traces to piece together a complete picture of prototype behavior. Deep memory can also reduce the need to set up multi-level triggers because you don't have to be as precise about the data you capture. All models in the 1670G series can be configured to have up to 2M samples of memory depth.

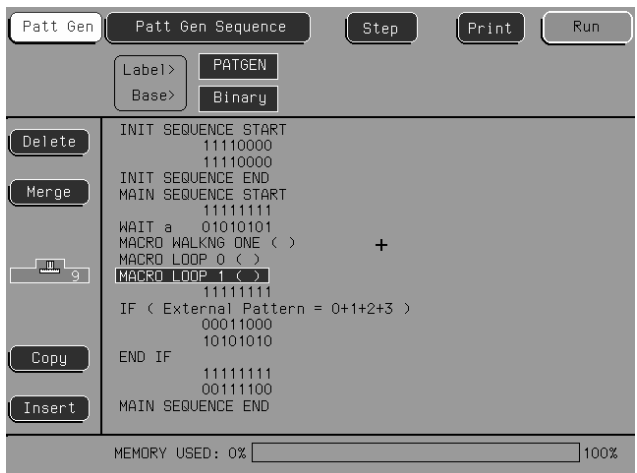

Optional 32-channel pattern generator allows stimulation of subsystems with realistic signals before the entire system is ready for testing.

Label > Base >	ADDR Symbol	MPC821/860 Inverse Assembler	Time Absolu
1032137	indie:fillup+0108	0 mr r9 r10	2.39sec
1032141	indie:fillup+010C	4 slwi r9 r9 2	2.39sec
1032145	indie:fillup+0110	8 add r8 r4 r9	2.39sec
1032149	indie:fillup+0114	C lwz r11 0000(r8)	2.39sec
1032153	indie:fillup+0118	0 add r11 r11 r7	2.39sec
1032157	indie:fillup+011C	4 stw r11 0000(r8)	2.39sec
1032161	indie:fillup+0120	8 mr r10 r6	2.39sec
1032165	indie:fillup+0124	C slwi r10 r10 2	2.39sec
1032169	indie:fillup+0128	0 add r9 r4 r10	2.39sec
1032173	indie:fillup+012C	4 lwz r8 0000(r9)	2.39sec
1032177	indie:fillup+0130	8 andl r8 r8 FFFF	2.39sec
1032181	indie:fillup+0134	C stw r8 0000(r9)	2.39sec
1032185	indie:fillup+0138	0 mr r7 r6	2.39sec
1032189	indie:fillup+013C	4 pgm 54E710**	2.39sec

2 M deep acquisition memory allows analysis of long periods of target system execution.

### Key Specifications and Characteristics for 1670G Series Benchtop Logic Analyzers

<b>Model</b>	1670G	1671G	1672G	1673G
<b>Channels</b>	136	102	68	34
<b>State Speed</b>	150 MHz			
<b>Timing Speed</b>	250 MHz on all channels, 500 MHz on half channels			
<b>Memory Depth</b>	64K memory standard (128K half channel timing)			
<b>Option 001</b>	256K memory (512K half channel timing)			
<b>Option 002</b>	2M memory (4M half channel timing)			
<b>Setup/ Hold Time</b>	3.5/0 ns to 0/3.5 ns adjustable in 500-ps increments			
<b>Input Resistance</b>	100 kΩ, ±2%			
<b>Parasitic Tip Capacitance</b>	1.5 pF			
<b>Triggering</b>	Up to 12 sequence levels with 10 pattern terms, 2 edge & glitch terms, 2 ranges and timers. Also includes 23 predefined trigger macros with graphical representations and plain language descriptions			
<b>I/O Standards</b>	2-GB hard disk drive, 1.44-MB flexible disk drive Ethernet LAN for file transfers and control GPIB, Parallel and RS-232 ports DIN mouse and keyboard ports Trigger in and Trigger out BNCs			
<b>Oscilloscope Option 003</b>	Number of scope channels: 2 Scope bandwidth: 500 MHz Scope sample rate: 2 GSa/s Scope vertical resolution: 8 bits Scope memory depth: 32K samples per channel			
<b>Pattern Generator Option 004</b>	Number of pattern generator channels: 32 Max clock speed: 100 MHz (32 Ch), 200 MHz (16 Ch) Max memory depth: 258,048 vectors			
<b>Training Kit Option 005</b>	Includes a training guide, example setup and data files, and a credit-card-sized target system board			

### Key Literature

Both of the following items are also available from the web site:

[www.agilent.com/find/LAbenchtops](http://www.agilent.com/find/LAbenchtops)

1670G Series Technical Specifications, p/n 5968-6421EN/EUS

### Ordering Information

Model	1670G	1671G	1672G	1673G
<b>Channels</b>	136	102	68	34
<b>Memory Options</b> (choose 1 or none)				
<b>Option 001 (256K)</b>				
<b>Option 002 (2M)</b>				
<b>Companion Tools</b> (choose 1 or none)				
<b>Option 003 (Scope)</b>				
<b>Option 004 (PatGen)</b>				
<b>Training Kit Option 005</b>				

16700  
16701  
16702

- Precisely correlated displays from analog signals to source code
- Simultaneous measurements on up to 8,160 channels
- Integrated emulation that takes advantage of on-chip debugging
- Tight coupling of logic analysis and emulation enables hardware and software designers to coordinate their debugging effort
- Remote web-enabled access
- Direct import of data into Microsoft Excel using BenchLink XL

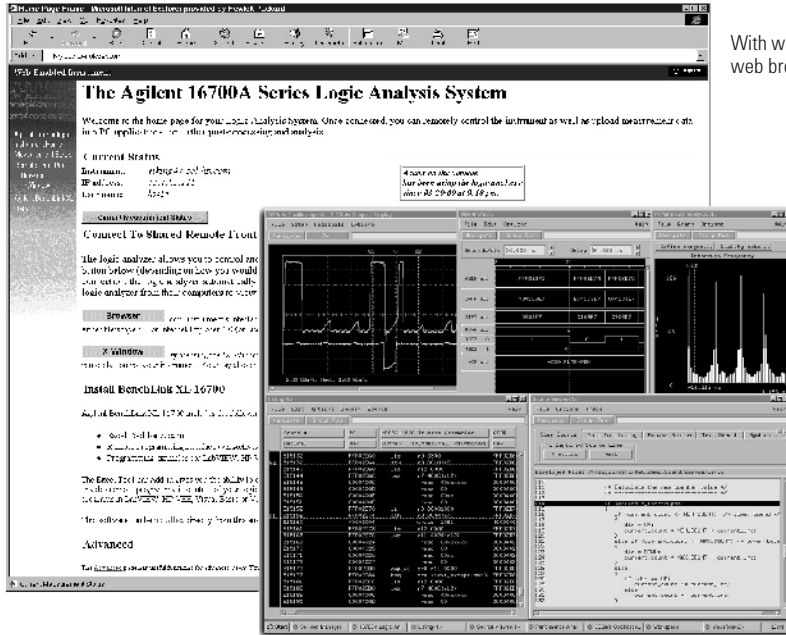

With web-enabled access, all you need is Internet access and web browser to access and control your logic analyzer.

View system resources in multiple domains, all time-correlated.

### Take Advantage of Integrated Insight During Hardware/Software Integration

Debugging today's digital systems is tougher than ever. Increased product requirements, complex software, and innovative hardware technologies all need to come together in a shorter amount of time to meet your market window.

When the prototype does not work as expected or needs tuning to meet performance requirements, you need test equipment that quickly provides reliable insight into your toughest problems. You want the answer to the problem, and you want it right away.

This is why Agilent has introduced a suite of logic analysis, emulation and software tools to give you the insight you need. Whether you are a hardware or software designer, Agilent has tools that address your debugging and verification needs.

### Debugging Tools That Will Help You Redefine Teamwork

The 16700 series logic analysis systems offer a single solution for hardware, software and systems debugging.

Hardware designers get the measurement power that made the 16500 logic analyzer the top seller for more than a decade, plus processor execution control, register access and other tools to explore software-dependent hardware problems such as interrupt handling.

Software designers get debugging and analysis tools that overcome the drawbacks of traditional emulation, while providing an easier way to solve hardware-dependent software problems that only a logic analyzer can uncover.

System designers get time-correlated views showing system activity from analog signals all the way to source code. The Agilent logic analysis system's cross-domain displays minimize the mysteries of hardware-software interaction, helping the team track problems back to root causes quickly and confidently.

### More Windows on the Problem

The 16700 series logic analysis systems allow you to examine system behavior from multiple angles—code execution, bus activity, timing and signal integrity—simultaneously. With integrated emulation capabilities, you gain insight into tough hardware/software integration problems even faster.

### On-Chip Emulation Tools Make Fixing Bugs Easier

Combining processor execution control with logic analysis lets you untangle the toughest hardware/software integration problems.

For specific microprocessor families that feature on-chip emulation, you can add an emulation module to connect the on-board debugging resources of the microprocessor to the logic analyzer and to a high-level debugger.

### Integrated Debugger Support

The 16700 series logic analysis systems offer you unprecedented visibility into software execution. Gain the ability to control your processor (break, step, run, stop) and modify/read registers with the addition of an emulation module. The emulation module provides the ability to connect to the industry's leading debuggers. This gives you complete hardware-assisted software debugging.

### Set-up Assistant Allows for Fast Analyzer Setup

Usability testing revealed that one of the hardest parts of using a logic analyzer is connecting it to the target and setting it up to make measurements. The set-up assistant in the 16700 series logic analysis systems guides you through all the necessary steps to get you to your first measurement quickly.

### Easy Access to System Insights

**Web-enabled logic analysis.** Your logic analyzer can now function as a web server, which means distributed teams can get the data they need, wherever they are. Plus you can launch and monitor tests from home, from the road, from wherever you need to be.

**PC file sharing.** Access PC disk drives from the logic analyzer or access the logic analyzer from networked PCs.

**Doing more with your data.** With BenchLink XL 16700's add-in tool for Microsoft Excel, it's easy to extract specific sets of the data from the analyzer for further analysis on your PC.



### 16702B features:

- Built-in, 12.1-inch 800x600 color touch display
- Dedicated hot keys for faster navigation
- Dedicated knobs for scaling and scrolling

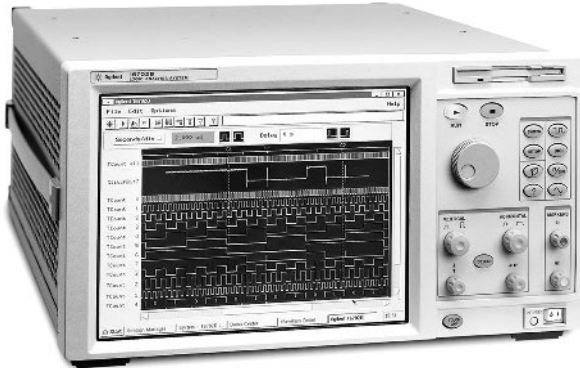

The 16702B's large touch screen display provides quick and easy access to key logic analysis functions and displays, as well as simultaneous views into system activity.



16700B, shown here with a 16701B expansion frame, offers comprehensive debugging capabilities for multiprocessor/bus designs.

### 16700 Series Logic Analysis System Mainframes

Modularity is the key to the 16700 series logic analysis system's long-term value. You purchase only the capability you need now, then expand as your needs evolve. All measurement modules are tightly integrated to provide time-correlated, cross-domain measurements. Combine up to 8 16700B series mainframes with expanders to provide up to 8,160 channels in one system.

#### 16700B and 16702B Mainframe Features

**Mainframe:** 5 measurement module slots; 1 emulation module slot

- Display 16702B has built-in, 12.1-inch touch display; 16700B requires external monitor
- Built-in, 40x CD-ROM drive
- 10/100 BaseT auto-sensing LAN
- 9 GB disk drive
- 128 MB system RAM

#### 16701B Features

(16701B requires 16700 series mainframe)

**Expansion Frame:** 5 measurement module slots;  
2 emulation module slots

Available Measurement Modules Provide:

- State clock speeds up to 400 MHz
- Timing analysis sampling rate up to 2 GHz
- State and timing memory depth up to 32 M samples
- Pattern generator clock speeds up to 300 M vectors/s
- Pattern generator memory depth up to 16 M vectors
- Emulation for industry leading microprocessors

#### Key Literature

16700 Series Logic Analysis Systems, Product Overview, p/n 5968-9661E

#### Ordering Information

System requires measurement modules. Refer to pgs 450–453

**16700B** Logic Analysis System Mainframe

**16702B** Logic Analysis System Mainframe

**16701B** Expansion Frame

#### 16700B and 16702B Options

**Opt 001** 17" Color Monitor

**Opt 003** Performance Upgrade

256 MB system RAM/1600x1200 video resolution

**Opt 008** External 18GB data drive

**Opt 009** External removable hard drive

**Opt 012** Multiframe

Enables connecting up to 8 16700B series frames with expanders into one system

(Refer to the literature listed above for 16700A series features)

**16700A** Logic Analysis System Mainframe

**16702A** Logic Analysis System Mainframe

#### 16700A and 16702A Options

**Opt 001** 17" Color Monitor

**Opt 003** Performance Upgrade 160 MB system RAM/

1600x1200 video resolution

**Opt 004** Add CD-ROM drive

**Opt 008** 18GB External data drive

#### Refurbished Logic Analysis Mainframes and Measurement Modules

For more information on the availability of the refurbished logic analysis systems see Chapter 19 Refurbished Test and Measurement Instruments, or visit our web site: [www.agilent.com/find/refurbished](http://www.agilent.com/find/refurbished)

16557D  
16710A  
16711A  
16712A  
16715A  
16716A  
16717A  
16750A  
16751A  
16752A

- State analysis clock speed up to 400 MHz
- 2 GHz Timing Zoom, simultaneous timing analysis on all channels
- Memory depth from 8K to 32M
- VisiTrigger, graphical triggering interface
- Eye finder automatically adjusts setup and hold on every channel

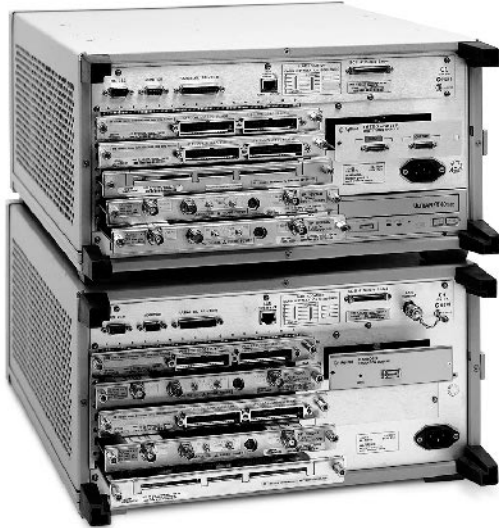

### Cost-Effective State Analysis up to 400 MHz, Memory Depth up to 32M

With state analysis speeds up to 400 MHz, memory depths up to 32M, 2-GHz Timing Zoom simultaneous timing analysis on all channels, and a range of prices to meet your budget, Agilent state and timing analysis modules deliver the measurement power you need for tomorrow, available today. Agilent's eye finder technology automatically adjusts the setup and hold on every individual channel in minutes, giving you the highest confidence in state measurements on today's high-speed buses.

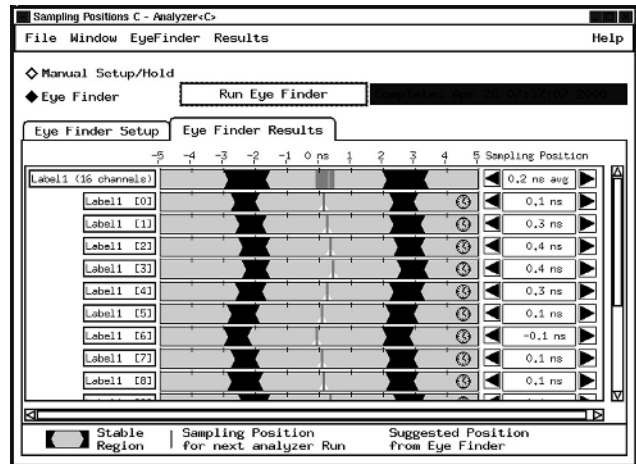

Eye finder technology, available on Agilent 16715A, 16716A, 16717A, 16750A, 16751A, and 16752A, automatically adjusts the setup and hold on every channel for high confidence in accurate state measurements on high-speed buses.

### Key Literature

Agilent 16700 Series Logic Analysis Systems, Product Overview, p/n 5968-9661E

### General-Purpose State and Timing Analysis Modules

Model	16557D	16710A	16711A	16712A	16715A	16716A	16717A	16750A	16751A	16752A
<b>Maximum state clock</b>	140 MHz <sup>2</sup>	100 MHz	100 MHz	100 MHz	167 MHz	167 MHz	333 MHz	400 MHz	400 MHz	400 MHz
<b>Maximum conventional timing sampling rate (half/full channels)</b>	500/250 MHz	500/250 MHz	500/250 MHz	500/250 MHz	667/333 MHz	667/333 MHz	667/333 MHz	800/400 MHz	800/400 MHz	800/400 MHz
<b>Memory depth (half/full channels)</b>	4/2 M samples <sup>1</sup>	16/8 K samples <sup>1</sup>	64/32 K samples <sup>1</sup>	256/128 K samples <sup>1</sup>	4/2 M samples <sup>1</sup>	1M/512K samples <sup>1</sup>	4/2 M samples <sup>1</sup>	8/4 M samples <sup>1</sup>	32/16 M samples <sup>1</sup>	64/32 M samples <sup>1</sup>
<b>2-GHz Timing Zoom</b>	No	No	No	No	No	Yes	Yes	Yes	Yes	Yes
<b>Setup/hold time window</b>	3 ns <sup>2</sup>	4 ns <sup>2</sup>	4 ns <sup>2</sup>	4 ns <sup>2</sup>	2.5 ns <sup>4</sup>	2.5 ns <sup>4</sup>	2.5 ns <sup>4</sup>	2.5 ns <sup>4</sup>	2.5 ns <sup>4</sup>	2.5 ns <sup>4</sup>
<b>Setup/hold time range</b>	3/0 to -5/3.5 ns	4/0 to 0/4 ns	4/0 to 0/4 ns	4/0 to 0/4 ns	4.5/-2.0 to -2.0/4.5 ns in 100 ps increments on individual channels	4.5/-2.0 to -2.0/4.5 ns in 100 ps increments on individual channels	4.5/-2.0 to -2.0/4.5 ns in 100 ps increments on individual channels	4.5/-2.0 to -2.0/4.5 ns in 100 ps increments on individual channels	4.5/-2.0 to -2.0/4.5 ns in 100 ps increments on individual channels	4.5/-2.0 to -2.0/4.5 ns in 100 ps increments on individual channels
<b>Channels per module</b>	68	102	102	102	68	68	68	68	68	68
<b>Maximum channels on a single time base (number of modules)</b>	340 (5)	204 (2)	204 (2)	204 (2)	340 (5)	340 (5)	340 (5)	340 (5)	340 (5)	340 (5)
<b>Number of state clocks/qualifiers<sup>5</sup></b>	4	6	6	6	4	4	4	4	4	4

<sup>1</sup>Increased memory depth in half channel timing mode only.

<sup>2</sup>Minimum setup/hold time specified for single edge, single clock acquisition. For single clock, multi-edge add 0.5 ns. For multi-clock, multi-edge, add 1 ns.

<sup>3</sup>Across 4 modules (272 channels). For >272-channels systems, maximum state speed is 100 MHz.

<sup>4</sup>Minimum setup/hold time is specified for single-edge, single-clock acquisition. For multi-clock, multi-edge, add 0.5 ns.

<sup>5</sup>Available only on the master card in multi-card configurations.

- Trigger directly on setup and hold violations down to 2 ns
- Make timing measurements across as many as 80 channels
- Characterize the performance of a high-speed ASIC or target system
- Capture the most complex problems with an easy-to-use trigger macro library

16517A  
16518A

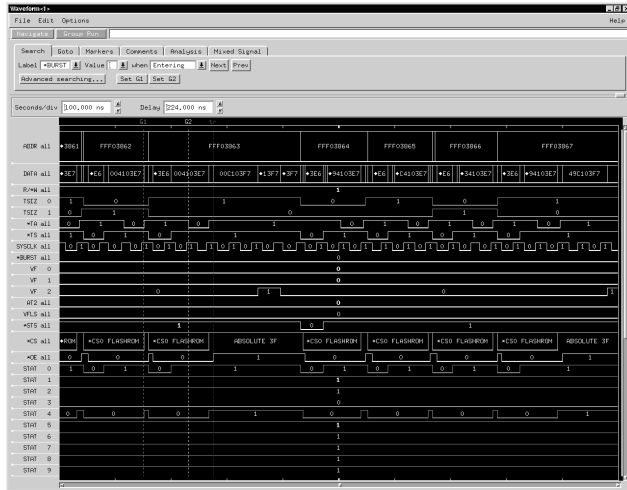

View circuit operation with better precision than ever before in a logic analyzer.

### 16517A/16518A High-Speed Timing Modules

#### Find the Cause of Elusive Problems

The 64K deep memory lets you capture data over many clock cycles while retaining the highest multichannel accuracy ever in a logic analyzer. Verify the timing of critical edges with 250 ps resolution across up to 40 channels, or 500 ps resolution across up to 80 channels. You can use 1 GHz synchronous state analysis to view high-speed data streams across up to 80 channels.

#### Precisely Characterize Setup or Hold Times

The 250 ps precision (channel-to-channel skew) allows your logic analyzer to be used in place of an oscilloscope for characterization. The high-channel count of a logic analyzer improves the efficiency of the characterization process.

The 16517A and 16518A are capable of triggering on violations of timing specifications. This is particularly powerful since it allows the wide channel count of the analyzer to look for setup and hold violations. Advanced setup/hold trigger macros are available to help you easily set up triggering.

#### Specifications

##### 16517A/16518A

**Maximum Timing Speed:** 2 GHz or 4 GHz<sup>1</sup>

**Maximum State Speed:** 1 GHz or 2 GHz<sup>2</sup>

**Memory Depth:** 64K or 128K<sup>1</sup>

**Channels-per-Card:** 16/16<sup>3</sup>

**Probe Input R&C:** 0.2 pF, then through 500 Ω, 3 pF and 100 kΩ

**Trigger Macro Library:** With 4 sequence levels

**Channel-to-Channel Skew:** 250 ps, typical

<sup>1</sup> Half-channel mode doubles memory depth and doubles timing speed.

<sup>2</sup> Maximum state speed with oversampling.

<sup>3</sup> 16518A expansion card requires 16517A master card. Up to four 16518A cards are supported by each 16517A.

#### Key Literature

Agilent 16700 Series Logic Analysis Systems, Product Overview, p/n 5968-9661E

#### Ordering Information

**16517A** 16-Channel, 4 GHz Timing/1 GHz State Master Card

**16518A** 16-Channel, 4 GHz Timing/1 GHz State Expander

16533A  
16534A

- Use automatic measurements to easily analyze a signal's behavior
- Set-up cross-module triggering with parametric and logical trigger conditions
- Combine scope and logic measurements in any configuration
- Quickly access information with windows interface and drag-n-drop features

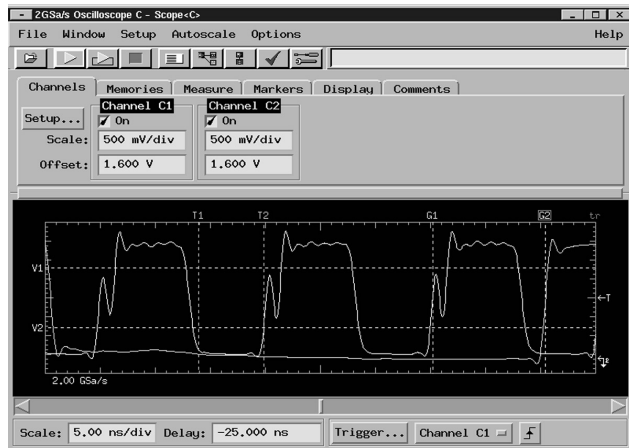

All primary oscilloscope control settings, including scale factors and trigger settings, are visible simultaneously.

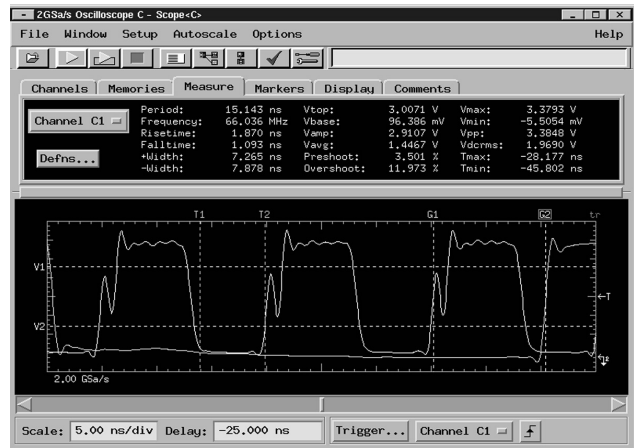

Explore analog signals and signal parameters using the digitizing oscilloscope modules.

### 16534A and 16533A Digitizing Oscilloscopes

#### Built-In, Full-Featured Digitizing Oscilloscopes

The Agilent 16534A and 16533A offer the features of a color digitizing oscilloscope integrated into your logic analysis system. These modules provide digitizing advantages such as autoscale, automatic measurements, powerful triggering, negative-time (pre-trigger) viewing, voltage markers, and time markers.

#### Use as a Standalone Scope with Many Channels

You can capture up to eight analog channels simultaneously (on a single time base). You can measure slow and fast events by adding additional oscilloscope modules to create a multiple time base digitizing oscilloscope. For large channel count measurements, you can configure as many as 20 scope channels in a single mainframe/expander system.

#### Get to the Answer Faster with an Intuitive User Interface

When installed in the 16700 or 16702 logic analysis system mainframes, these oscilloscope modules make powerful measurement and analysis accessible and uncomplicated, so you can find the answer to tough debugging problems in less time. Oscilloscope controls are easy to find, recognize, and use.

### Gain Insight Faster with Automatic Measurements and Time and Voltage Markers

The 16534A and 16533A oscilloscope modules allow you to characterize signals quickly with automatic measurements of rise time, voltage, pulse width and frequency. You can also measure timing and voltage margins using convenient time and voltage markers. Four independent voltage markers are available.

The global time markers of the Agilent logic analysis systems let you make time-correlated measurements across state, timing and oscilloscope measurements. Two local time markers are available in addition to two global time markers.

#### Specifications

	16534A	16533A
Sample Rate	2 GSa/s	1 GSa/s
Bandwidth <sup>1</sup>	500 MHz	250 MHz
Rise Time <sup>2</sup>	700 ps	1.4 ns
Time-Interval Accuracy	± 100 ps	± 100 ps
ADC Resolution	8 bits	8 bits
Waveform Record Length	32K	32K
Channels-per-Card	2	2
Max. Single Time Base Channels	8	8
Max. Channels-per-System	20	20

<sup>1</sup> Specifications

<sup>2</sup> Rise time is calculated from: Rise time = 0.35/bandwidth

#### Key Literature

Agilent 16700 Series Logic Analysis Systems, Product Overview  
p/n 5968-9661E

#### Ordering Information

16533A 2 Channel, 1 GSa/s Oscilloscope Module  
16534A 2 Channel, 2 GSa/s Oscilloscope Module



- Test systems under a variety of operating scenarios
- Simulate hardware still under development to speed up software development or system debugging
- Easily develop complex tests with macros, repeat loops, pattern fills, and state-to-pattern conversion
- Create a functional ASIC verification platform
- Utilize remote programming commands to create a stimulus/response test tool

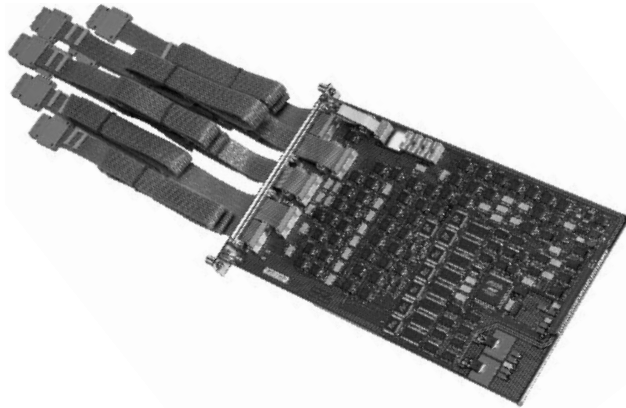

Use the 16720A or 16522A pattern generator module to create virtually any digital stimulus you need.

### 16720A and 16522A Digital Pattern Generator Modules

#### Digital Stimulus for Prototype Turn-on and Evaluation

The Agilent 16720A and 16522A digital pattern generator modules are the perfect tools for testing your digital design. See how your system responds to specific signals or clock speeds. Correlate data captured with other Agilent state and timing modules to verify correct operation. The 16720A and 16522A pattern generators provide a number of features to help you turn on and evaluate prototypes quickly:

##### Both Pattern Generators Provide:

- Synchronized clock output
- Wait for input pattern
- Initialize block is run once in a repetitive run
- Macros and repeat loops simplify creation of stimulus programs
- Pattern fills and state to pattern provide quick development of complex stimulus programs

##### 16720A 300 MVector/sec Pattern Generator

- Vectors up to 240 bits wide
- Speeds up to 300 Mvectors/sec
- Up to 16 MVector memory depth
- Pattern Generator Binary (PGB) file format for vectors sets >1 MVectors
- ASCII input file format for editable vector sets up to 1 MVectors
- Compatible with all Agilent 16700 series logic analysis mainframes only

##### 16522A 200 MVectors/sec Pattern Generator

- Vectors up to 200 bits wide
- Speeds up to 200 Mvectors/sec
- Memory depth of 256K Vectors
- Conditional branch at 50 MHz
- ASCII input file format
- Compatible with Agilent 16500B/C and 16700 Series logic analysis mainframes

The pattern generator is designed for operation with the external clock and data pods and lead sets. Both the data pods and data cables use standard connectors that you can design into your system.

##### Lead Set Characteristics

**10498A 8-Channel 6" Probe Lead Set:** Provides the most cost-effective lead set for the 16720A and 16522A clock and data pods. IC clips are not included.

**10474A 8-Channel 12" Probe Lead Set** is identical to the 10498A but is longer and suitable for speeds up to 200 MVectors/s.

**10347A 8-Channel Probe Lead Set:** Provides a 50-ohm coaxial lead set for unterminated signals, required for 10465A ECL Data Pod (unterminated). IC clips are not included.

##### Data Pod Characteristics

###### 10461A TTL Data Pod

**Maximum Clock:** 200 MHz  
**Skew:** Typical < 2 ns; worst case = 4 ns

###### 10462A 3-State TTL/CMOS Data Pod

**Maximum Clock:** 100 MHz  
**Skew:** Typical < 4 ns; worst case = 12 ns

###### 10464A ECL Data Pod (terminated)

**Maximum Clock:** 300 MHz  
**Skew:** Typical < 1 ns; worst case = 2 ns

###### 10465A ECL Data Pod (unterminated)

**Maximum Clock:** 300 MHz  
**Skew:** Typical < 1 ns; worst case = 2 ns

###### 10469A 5 Volt PECL Data Pod

**Maximum clock:** 300 MHz  
**Skew:** typical < 500 ps; worst case = 1 ns

###### 10471A 3.3 Volt LVPECL Data Pod

**Maximum clock:** 300 MHz  
**Skew:** typical < 500 ps; worst case = 1 ns

###### 10473A 3-State 2.5 Volt Data Pod

**Maximum Clock:** 300 MHz  
**Skew:** Typical < 1 ns; worst case = 2 ns

###### 10476A 3-State 1.8 Volt Data Pod

**Maximum Clock:** 300 MHz  
**Skew:** Typical < 1.5 ns; worst case = 2.5 ns

###### 10483A 3-State 3.3 Volt Data Pod

**Maximum Clock:** 300 MHz  
**Skew:** Typical < 1 ns; worst case = 2 ns

##### Clock Pod Characteristics

###### 10460A TTL Clock Pod Clock

**Clock Output Rate:** 100 MHz maximum

###### 10463A ECL Clock Pod

**Clock Output Rate:** 300 MHz maximum

###### 10468A 5 Volt PECL Clock Pod

**Clock Output Rate:** 300 MHz maximum

###### 10440A 3.3 Volt LVPECL Clock Pod

###### 10472A 2.5 Volt Clock Pod

**Clock Output Rate:** 200 MHz maximum

###### 10475A 1.8 Volt Clock Pod

**Clock Output Rate:** 200 MHz maximum

###### 10477A 3.3 Volt Clock Pod

**Clock Output Rate:** 200 MHz maximum

#### Key Literature

Agilent Technologies 16700 Series Logic Analysis System  
Product Overview p/n 5968-9661E

Probing Solutions for Agilent Logic Analysis Systems Product Overview  
p/n 5968-4632E

#### Ordering Information

**16720A** 48-channel 300-MVector/s Pattern Generator Module

**16522A** 40-Channel 200-MVector/s Pattern Generator Module

##### Lead Sets

**10498A** 8-Channel 6-inch Probe Lead Set

**10474A** 8-Channel 12-inch Probe Lead Set

**10347A** 8-Channel co-axial Probe Lead Set

##### Data and Clock Pods

**10461A** TTL Data Pod

**10462A** 3-State TTL/CMOS Data Pod

**10464A** ECL Data Pad (terminated)

**10465A** ECL Data Pad (unterminated)

**10469A** 5 Volt PECL Data Pod

**10471A** 3.3 Volt LVPECL Data Pod

**10460A** TTL Clock Pod

**10463A** ECL Clock Pod

**10468A** 5 Volt PECL Clock Pod

**10472A** 2.5 Volt Clock Pod

**10473A** 3-State 2.5 Volt Data Pod

**10475A** 1.8 Volt Clock Pod

**10476A** 3-State 1.8 Volt Data Pod

**10477A** 3.3 Volt Clock Pod

**10483A** 3-State 3.3 Volt Clock Pod

16720A  
16522A

B4600B  
B4601B  
B4605B  
B4620B  
B4640B

- Uncover hidden timing and code flow problems
- Link causes and events across domains, from analog signals to digital signals to source code
- Move from high-level performance analysis to detailed troubleshooting in seconds
- View serial data in a parallel format
- Create custom tools to extract information buried by proprietary protocols



A custom tool extracts system information from the ADDR and DATA trace and converts it to easily understood text that speeds insight into system problems.

### Get an Accurate Picture of In-Target Software Performance

The post-processing software tool sets available for the 16700 series logic analysis systems rapidly consolidate large amounts of data into displays that provide insight into your system's behavior. The tool sets provide you with the insight needed to solve tough hardware, software, and system integration problems, allowing you to get quality products to market on time.

#### B4600B System Performance Analysis Tool Set

The B4600B system performance analysis (SPA) tool set for the 16700 series logic analysis systems provides statistical representations of data captured by the measurement modules. The SPA tool set helps to find the routines that are called most often in your system, identify inefficient peripheral use, and pinpoint processes that use too much CPU time. Profile your system's performance to identify system bottlenecks and to identify areas needing optimization.

The SPA tool set helps evaluate the parameters, performance, and responsiveness of your target system and provides answers to the following questions:

- What functions are most often executed by the processor?
- What is the relative workload of each processor in a multiple-processor system?
- What is the minimum, maximum and average execution time of a function (including calls)?
- How many interrupts does the system receive per time slice?
- What is the response time of my system to an external event?
- Is this function or variable accessed by the application?
- How does the system react when it receives too many interrupts?
- Are the stack and cache sizes adequate?

#### B4601B Serial Analysis Tool Set

The B4601B serial analysis tool set for the 16700 series logic analysis systems quickly converts acquired serial bit streams to parallel format for easy viewing and analysis. The serial tool also allows you to process frame information to isolate the data you want to analyze.

#### B4605B Tool Development Kit

Custom tools can be created with a B4605B tool development kit using the C programming language. Custom tools can be used to extract information buried by proprietary protocols. Text can be added to a listing that enhances understanding of what is going on in the system. In addition, states that are unique to your system can be highlighted in color. Perform extensive analysis of your system traces using algorithms developed by you. Write the results of this analysis to a file of virtually any format. Accumulate information about repetitive traces in a file that can then be pulled into an Excel spreadsheet.

#### B4620B Source Correlation Tool Set

The B4620B source correlation tool set combines the versatility of an Agilent logic analysis system with an interface that is tailored for correlating software measurements with other system activity. Observe software execution by a microprocessor without halting the system or adding instructions to the code.

The Agilent source correlation tool set provides a link between your trace listing and high-level source code language. Once a trace is complete, the corresponding high-level source code and microprocessor mnemonics are also displayed.

Symbol names from your source code, such as function and variable names, can be used to specify trigger conditions, or can be viewed in trace listings. Examples of supported symbols include: variable names, function and procedure names, and module names. Many file formats are supported.

#### B4640B Data Communications Tool Set

The B4640B data communications tool set allows you to debug parallel-data communication buses in a switching or routing system. The parallel-data bus width is limited only by the number of available channels. Each protocol layer is displayed with a different color in the logic analyzer lister display to allow easy viewing of the protocol data. Payload information is included after the header in a raw hex format.

The powerful protocol trigger macro allows easy trigger setup on standard or custom protocol fields and eliminates the need to manually configure the trigger sequencer for complex measurements. All packets or cells are time-stamped in the logic analyzer for time-correlation measurements with other system buses, such as a microprocessor, memory interface, PCI bus, or other Utopia bus.

#### Key Literature

Agilent Technologies 16700 Series Logic Analysis System, p/n 5968-9661E

#### Ordering Information

- B4600B** System Performance Analysis Tool Set
- B4601B** Serial Analysis Tool Set
- B4605B** Tool Development Kit
- B4620B** Source Correlation Tool Set
- B4640B** Data Communications Tool Set

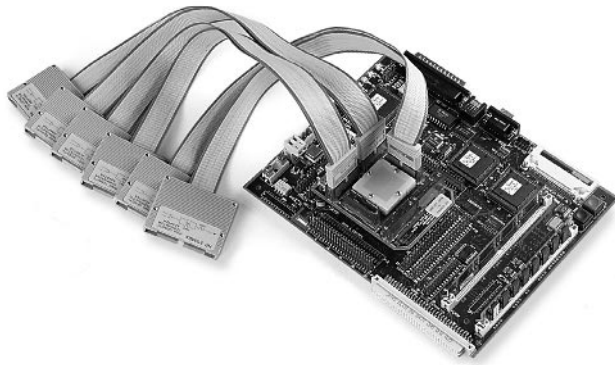

The E9484B Option 002 analysis probe provides an easy way to probe the pinless Motorola PowerPC 821/860 BGA package.



Emulation probes provide an easy, non-intrusive connection to your chip's debug port.

### Configure a Logic Analysis or Emulation System

For a complete processor or bus solution you need tools that probe, acquire, and analyze your system's data. Agilent and its complementary vendors provide an extensive range of quality tools that offer non-intrusive, full-speed, real-time analysis and processor execution control to accelerate your debugging process.

### Real-Time Analysis

Component	Model #	Description	Feature	Capability
<b>Frame</b>	16700 16701 16702	5 slot mainframe 5 slot expansion mainframe 5 slot mainframe w/flat panel display		Support up to 1,020 channels of state/timing, oscilloscope, pattern generation and emulation modules.
<b>Logic Analyzer Measurement Module(s)</b>	See page 450	Provides state and timing acquisition.	Real-Time Trace	Capture and analyze code flow and data flow without halting the target system. Monitor processor activity in relation to system buses, other processors, or I/O devices.
			Time-Tagged Trace Execution	Time-correlate analog, timing and state events across your entire system. Identify real-time performance problems. Check the execution time of specific functions.
			Advanced Triggering	Capture and focus on problems that occur infrequently or only after a specific series of events.
			Non-intrusive	Run target system at full speed.
<b>Analysis Probe</b>	See page 457		Probing	Access all processor signals through reliable, quick, easy target connection.
			Configuration Files	Quick, easy analyzer setup correlated to hardware connection.
			Inverse Assembler	Disassemble trace into processor mnemonics.
<b>Source Correlation Tool Set</b>	B4620B	Provides correlation of acquired trace to high-level source code by using information from your object file to build a database of source files, line numbers, and symbol information.		Time-correlate acquired trace to high-level source code. Step through trace at assembly level or source code level. Easily locate a problem's cause by stepping backward from the symptom occurrence.

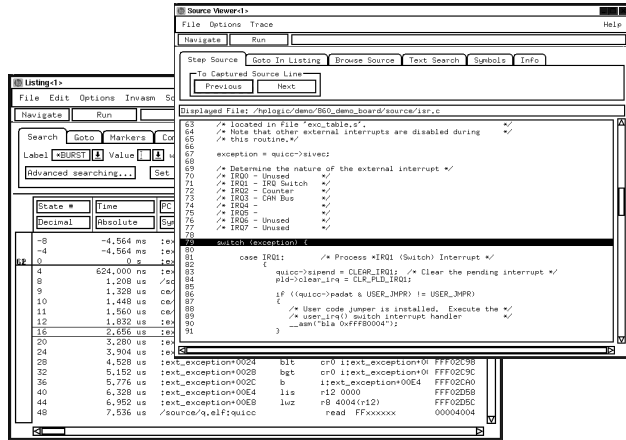

Inverse assembled trace time-correlated to source code using the source correlation tool set.



Emulation modules provide an integrated solution for the 16700 and 16702 logic analysis systems that combines logic analysis with non-intrusive connection to your processor's on-chip debug port.

## Processor Control

Component	Model #	Description	Feature	Capability
Emulation Module	See page 457	Processor control integrated into 16700 and 16702 frames.	Easy, non-intrusive connection	Access the debug pins of the target microprocessor without affecting any other signals.
			Program execution control	Reset, run/break, start/stop, single step.
			High-speed code download	Exceptional download speed. Download code to target RAM or FLASHROM.
Emulation Probe	See page 457	Standalone processor control. Controlled over local area network (LAN).	Easy, non-intrusive connection	Access the debug pins of the target microprocessor without affecting any other signals.
			Program execution control	Reset, run/break, start/stop, single step.
			High-speed code download	Exceptional download speed. Download code to target RAM or FLASHROM.
Emulation Control Interface	Standard on 16700 and 16702 mainframes.	Multiple windowed interface for emulation modules and probes.	Control of emulation module/probe	Setup breakpoints, read and modify memory and I/O in the target system.
High-Level Debugger	Third-Party Vendor	Source-level software debug Control of emulation module/probe.	Hardware-assisted software debug	Debug of C or C++ and the ability to access on-chip debug features via Agilent emulation module/probe.
Emulation Solution	See page 457	A bundle of products for ordering convenience. Includes an analysis probe, source correlation tool set and emulation module/probe.	Provides real-time trace, emulation, and source correlation.	See pages 454 and 455 for specific details.

## Support for New Microprocessor and Bus Interfaces

Agilent Technologies is committed to providing support for the latest microprocessors and bus interfaces. Agilent works with semiconductor vendors and premier channel partners to ensure early development solutions for new processors and bus interfaces. Please see page 457 for a complete listing of supported devices. If you do not see your processor listed, please contact your local sales office for the latest processor support update.

## Custom Inverse Assemblers

Several options are available for custom development. One of these options is Agilent's Premiere Channel Partner program. Several Premiere Channel Partners, with years of inverse assembly and custom hardware development experience, can deliver quality custom solutions.

## Key Literature

Processor and Bus Support for Agilent Logic Analysis Systems, p/n 5966-4365E



### Selection Guide Key<sup>1</sup>

AD = Adapter  
 AP = Analysis Probe  
 EM = Emulation Module  
 EMG = Emulation Migration  
 EP = Emulation Probe  
 ES = Emulation Solution  
 IA = Inverse Assembler  
 MEM = Memory Emulation  
 NT = N-Trace

Device Manufacturer and Name	Package Type	Prod Type	State	Timing	Emulation	Min# / Product Max# or Channel Pods	Partner
<b>Actel FPGA</b>							
ACT1280	176-PGA	AP	.	.	.	-/9	Corelis
<b>Altera EPLD</b>							
EPM5192-P	84-PGA	AP	.	.	.	-/5	Corelis
<b>AMD</b>							
29000/50	PGA	AP	.	.	.	5/9	Corelis
29030	PGA	AP	.	.	.	5/7	Corelis
29040	PGA	AP	.	.	.	5/9	Corelis
29200	PQFP	AP	.	.	.	5/10	Corelis
29202	PQFP	AP	.	.	.	5/8	Corelis
29205	PQFP	AP	.	.	.	5/6	Corelis
29240/43/45	PQFP	AP	.	.	.	5/11	Corelis
186CC	IA Only	IA	.	.	.	4/4	Corelis
186EM/ES	PQFP	AP	.	.	.	4/8	Corelis
	TQFP	AP	.	.	.	4/8	Corelis
188EM/ES	PQFP	AP	.	.	.	4/8	Corelis
	TQFP	AP	.	.	.	4/8	Corelis
<b>Aptix</b>							
AX1024D FPIC	PGA	AP	.	.	.	-/4	Aptix
<b>ARM</b>							
ARM7	IA Only	AP	.	.	.	4/4	E9595A #001
ARM7 Thumb, ARM9 Thumb	IA Only	ES <sup>1</sup>	.	.	.	4/4	E9495B #001
ARM7 Thumb, ARM9 Thumb Families		EP <sup>4</sup>	.	.	.		E5900B #300
		EM <sup>4</sup>	.	.	.		E5901B #300
		EMG <sup>1</sup>	.	.	.		E5902B #300
ARM7.9 -ETM	ALL	AP	.	.	.	2/2	E9595A #002
		NT	.	.	.		E5903A #300
			.	.	.		E5903A #301
<b>Atmel</b>							
AT91 (ARM7TDMI)	100-QFP	AP	.	.	.	6/8	Europe Tech.
		MEM	.	.	.		
<b>AT&amp;T</b>							
92010 (Hobbit)	PGA	AP	.	.	.	6/6	Corelis
<b>Dallas</b>							
80C320	DIP	AP	.	.	.	2/3	ET
	PLCC	AP	.	.	.	2/3	ET
	PQFP	AP	.	.	.	2/3	ET
<b>DEC</b>							
See 'Intel Other' for Strong ARM products							
<b>Fujitsu</b>							
MB869860	IA	.	.	.	.	6/6	ALD
<b>Hitachi</b>							
SH3-7709A/29	208-QFP	AP	.	.	.	6-10	E9605A #002
		EP <sup>4</sup>	.	.	.		E5900A #720
		EM <sup>4</sup>	.	.	.		E5901A #720
		EMG <sup>4</sup>	.	.	.		E5902A #720
SH4-SH7750	208-QFP	AP	.	.	.	8/10	E9598A #002
		ES	.	.	.	8/10	E9498A #002
		EP	.	.	.		E5900A #710
		EM	.	.	.		E5901A #710
		EMG	.	.	.		E5902A #710
<b>IBM PowerPC 4XX Family</b>							
PPC 403	IA Only	AP	.	.	.	5/8	E2449B
GA/B/C/CX							
PPC 401/403	All	EP <sup>4</sup>	.	.	.		E5900B #060
		EM <sup>4</sup>	.	.	.		E5901B #060
<b>IBM PowerPC 6XX Family</b>							
PPC 601	IA Only	IA	.	.	.	8/10	E2449B
PPC 603, 603e, 603ev, 603ei	IA Only	AP	.	.	.	8/10	E9587A #001
		ES <sup>4</sup>	.	.	.	8/10	E9487A #001
	240-PQFP	AP	.	.	.	8/10	E9587A #002
		ES <sup>4</sup>	.	.	.	8/10	E9487A #002
PPC 603/e/ev, 604/e/ev	All	EP <sup>4</sup>	.	.	.		E5900B #060
		EM <sup>4</sup>	.	.	.		E5901B #060
		EMG <sup>4</sup>	.	.	.		E5902B #060
<b>IBM PowerPC 7XX Family</b>							
PPC 740/750	IA Only	AP	.	.	.	8/10	E9586A #001
		ES <sup>4</sup>	.	.	.	8/10	E9486B #001
		EP <sup>4</sup>	.	.	.		E5900B #070
		EM <sup>4</sup>	.	.	.		E5901B #070
		EMG <sup>4</sup>	.	.	.		E5902B #070

Device Manufacturer and Name	Package Type	Prod Type	State	Timing	Emulation	Min# / Product Max# or Channel Pods	Partner
<b>IDT</b>							
R3041	PLCC	AP	.	.	.	5/6	Corelis
R3051/52/81/82	PLCC	AP	.	.	.	5/6	Corelis
R32364	TQFP	AP	.	.	.	5/7	Corelis
R36100	MQUAD	AP	.	.	.	6/12	Corelis
R4000/4400PC	PGA	AP	.	.	.	8/9	Corelis
R4600/4700	PGA	AP	.	.	.	6/7	Corelis
	MQUAD	AP	.	.	.	6/7	Corelis
R4640	PQFP	AP	.	.	.	4/4	Corelis
R4650	MQUAD	AP	.	.	.	6/7	Corelis
R5000	PGA	AP	.	.	.	6/9	Corelis
RC64474	PQFP	AP	.	.	.	4/4	Corelis
RC64475	MQUAD	AP	.	.	.	6/7	Corelis
<b>Intel Pentium</b>							
Pentium 567\66	PGA	AP	.	.	.	-/12	ET
Pentium and Pentium w/MMX	296-SPGA	AP	.	.	.	8/10	E9592A #002
		ES <sup>4</sup>	.	.	.	8/10	E9492A #002
		EP <sup>4</sup>	.	.	.		E5900A #500
		EM <sup>4</sup>	.	.	.		E5901A #500
Pentium Pro	387-SPGA	AP	.	.	.	10/10	E2466B
Pentium II, III	Slot 1	AP <sup>2</sup>	.	.	.	12/12	E2487C
			.	.	.		E2492B
Pentium II, III	Slot 2	AP <sup>2</sup>	.	.	.	12/12	E2487C
Xeon			.	.	.		E2492C
Celeron	SEP	AP <sup>2</sup>	.	.	.	12/12	E2487C
266, 300, 300A			.	.	.		E2492B
333, 400, 433, 500, 533 MHz			.	.	.		
Celeron	PPGA	AP <sup>2</sup>	.	.	.	12/12	E2487C
300A, 333, 366, 400, 433, 466 MHz			.	.	.		E2492E
Pentium II	Mobile	AP	.	.	.	12/12	E2494S
Pentium Pro, II, III, Celeron		EP <sup>4</sup>	.	.	.		E5900A #510
		EM <sup>4</sup>	.	.	.		E5901A #510
<b>Intel 80X86</b>							
8086/8088	DIP	AP	.	.	.	3/3	ET
80186/88/XL	PLCC	AP	.	.	.	3/6	ET
80C186EB	PLCC	AP	.	.	.	3/6	ET <sup>5</sup>
	PQFP	AP	.	.	.	3/6	ET
80386EX	132-PQFP	AP	.	.	.	4/6	E2454A
<b>Intel 80960X</b>							
80960CA	PGA	AP	.	.	.	-/5	Corelis
80960H-Series	PGA	AP	.	.	.	6/7	E2473A
80960J-Series	PGA	AP	.	.	.	5/6	E2464A
	PQFP	AD <sup>12</sup>	.	.	.		E5337A
80960KA/KB/MC	PGA	AP	.	.	.	5/6	Corelis <sup>1,3</sup>
80960RD,RP	BGA	AP	.	.	.	5/6	E2484A
80960SA,SB	PLCC	AP	.	.	.	4/4	ET
<b>Intel Other</b>							
8085	DIP	AP	.	.	.	2/3	ET
8031/51	DIP	AP	.	.	.	2/3	ET <sup>4</sup>
	PLCC	AP	.	.	.	2/3	ET <sup>5</sup>
80860XR	PGA	AP	.	.	.	-/5	Corelis
SA-110	TQFP	AP	.	.	.	5/6	Corelis
<b>LSI Logic</b>							
LR33000/33050	PGA	AP	.	.	.	5/8	Corelis
LR33020	PGA	AP	.	.	.	7/11	Corelis
LR333X0	PQFP	AP	.	.	.	5/8	Corelis
<b>Motorola PowerPC 5XX Family</b>							
MPC505/509	160-PQFP	AP	.	.	.	6/10	E9585A #002
		ES <sup>4</sup>	.	.	.	6/10	E9485A #002
MPC555	IA Only	AP	.	.	.	6/14	E9610A #001
		ES <sup>4</sup>	.	.	.	6/14	E9510A #001
MPC 505/509/555 All		EP <sup>4</sup>	.	.	.		E5900A #050
		EM <sup>4</sup>	.	.	.		E5901A #050
		EMG <sup>4</sup>	.	.	.		E5902A #050
<b>Motorola PowerPC 6XX Family</b>							
PPC 601	IA Only	IA	.	.	.	8/10	E2449B
PPC 603/e/ev	IA Only	AP	.	.	.	8/10	E9587A #001
		ES <sup>4</sup>	.	.	.	8/10	E9487A #001
	240-PQFP	AP	.	.	.	8/10	E9587A #002
		ES <sup>4</sup>	.	.	.	8/10	E9487A #002
PPC 603/e/ev	All	EP <sup>4</sup>	.	.	.		E5900B #060
604/e/ev		EM <sup>4</sup>	.	.	.		E5901B #060
		EMG <sup>4</sup>	.	.	.		E5902B #060

<sup>1</sup> Refer to publication #5966-4365E for additional information.  
<sup>2</sup> Requires purchasing multiple products.  
<sup>3</sup> Multiple products are available with varying prices.  
<sup>4</sup> Debuggers are available from third-party vendor(s). See page 459  
<sup>5</sup> Contact vendor for pricing information.

Device Manufacturer and Name	Package Type	Prod Type	State	Timing	Emulation	Min#/ Max# Pods	Product or Channel Partner
<b>Motorola PowerPC 7XX Family</b>							
PPC 740/750, 745/755	IA Only	AP	•	•		8/10	E9586A #001
		ES <sup>4</sup>	•	•	•	8/10	E9486B #001
PPC 740/750	All	EP <sup>4</sup>					E5900B #070
		EM <sup>4</sup>					E5901B #070
		EMG <sup>4</sup>					E5902B #070
<b>Motorola PowerPC 74XX Family</b>							
MPC7400	IA Only	IA	•	•		8/10	E9613B #001
		ES			•		E9513B #001
		EP			•		E5900B #110
		EM			•		E5901B #110
		EMG			•		E5902B #110
<b>Motorola PowerPC 8XX Family</b>							
MPC801	IA Only	AP	•			6/6	Corelis
MPC823	IA Only	AP	•			6/6	Corelis
		BGA	•	•		6/11	Corelis
MPC850, 855	IA Only	AP	•			6/6	Corelis
		BGA	•	•		6/11	Corelis
MPC860DP/P/T	IA Only	AP	•			6/12	E9584B #001
		ES <sup>4</sup>	•	•	•	6/12	E9484B #001
		357-BGA	•	•		6/12	E9584B #002
		ES <sup>4</sup>	•	•	•	6/12	E9484B #002
MPC860, 850,860	All	EP <sup>4</sup>			•		E5900B #080
		EM <sup>4</sup>			•		E5901B #080
		EMG <sup>4</sup>			•		E5902B #080
<b>Motorola PowerPC 82XX Family</b>							
MPC8240	IA Only	AP	•	•		8/14	E9611A #001
		ES <sup>4</sup>	•	•	•	8/14	E9511B #001
		352-BGA	•	•		8/14	E9611A #002
		ES <sup>4</sup>	•	•	•	8/14	E9511B #002
MPC8260	IA Only	AP	•			8/22	E9603A #001
		ES <sup>4</sup>	•	•	•	8/22	E9503B #001
		480-BGA	•	•		8/22	E9603A #002
		ES <sup>4</sup>	•	•	•	8/22	E9503B #002
MPC8240/60	All	EP <sup>4</sup>			•		E5900B #100
		EM <sup>4</sup>			•		E5901B #100
		EMG <sup>4</sup>			•		E5902B #100
<b>Motorola 68K</b>							
68000/10	DIP	AP	•	•		3/4	ET
	SDIP	AP	•	•		3/4	ET
	PLCC	AP	•	•		3/4	ET
	PGA	AP	•	•		3/4	ET
68000/HC000	PGA	AP	•	•		3/7	E2447AA
68HC000/001	PGA	AP	•	•		3/4	ET <sup>5</sup>
	PLCC	AP	•	•		3/4	ET
68EC000	PLCC	AP	•	•		3/7	E2447AB
68008	DIP	AP	•	•		3/4	ET
68020	PGA	AP	•	•		5/6	E2426A
	PQFP	AD <sup>1,2</sup>					#1CC
68030	PGA	AP	•			5/5	E2406A
	PQFP	AD <sup>1,2</sup>					#1CC
68EC030	PGA	AP	•			5/5	E2406A
68060/68040	PGA	AP	•	•		6/8	E2459A
<b>Motorola CPU32 Family</b>							
68331/32/34/35	132-PQFP	AP	•	•		4/12	E9589A #002
		ES <sup>4</sup>	•	•	•	4/12	E9489A #002
68331/32	144-TQFP	AP	•	•		4/12	E9589A #003
		ES <sup>4</sup>	•	•	•	4/12	E9489A #003
68336/76	160-PQFP	AP	•	•		4/12	E9596A #002
		ES <sup>4</sup>	•	•	•	4/12	E9496A #002
68360, 68EN360, 68MH360	241-PGA	AP	•	•		6/12	E9590A #002
		ES <sup>4</sup>	•	•	•	6/12	E9490A #002
	240-PQFP	AP	•	•		6/12	E9590A #003
		ES <sup>4</sup>	•	•	•	6/12	E9490A #003
68330/1/2/4/5/6, 68340/1/9, 68360/EN/MH, 68376, 68F333, 68CK338		EP <sup>4</sup>					E5900A #030
		EM <sup>4</sup>					E5901A #030
		EMG <sup>4</sup>					E5902A #030
68340	PGA	AP	•	•		3/7	Corelis
68340	PQFP	AP	•	•		4/7	ET
<b>Motorola Coldfire</b>							
CF5202/3	100-TQFP	AP	•	•		6/6	ALD
<b>Motorola 6830X</b>							
68302	PGA	AP	•	•		3/6	Corelis
	PQFP	AP	•	•		3/6	Corelis
68EN302	TQFP	AP	•	•		3/7	Corelis
68LC302	PGA	AP	•	•		3/6	Corelis
	TQFP	AP	•	•		3/6	Corelis

<sup>1</sup> Refer to publication #5966-4365E for additional information.

<sup>2</sup> Requires purchasing multiple products.

<sup>3</sup> Multiple products are available with varying prices.

Device Manufacturer and Name	Package Type	Prod Type	State	Timing	Emulation	Min#/ Max# Pods	Product or Channel Partner
<b>Motorola M-Core Family</b>							
DFP99, EIM Interface, MMC2001, 2003, 2499	IA Only	IA	•	•		4/4	Corelis
Redcap1/2, Wally	IA Only	IA	•	•		4/4	Corelis
Whitecap	PGA	AP	•	•		4/4	Corelis
Aruba, Cayman	IA Only	AP	•	•		4/6	E9612A #001
		ES <sup>4</sup>	•	•	•	4/6	E9512A #001
	All	EP <sup>4</sup>			•		E5900A #090
		EM <sup>4</sup>			•		E5901A #090
		EMG <sup>4</sup>			•		E5902A #090
<b>Motorola DSPs</b>							
56116/156/166	—	IA	•			5/5	Corelis
56303	TQFP	AP	•	•		4/7	Corelis
56309	TQFP	AP	•	•		4/7	Corelis
56651/2/3/4	IA Only	AP	•	•		4/4	Corelis
56690	IA Only	AP	•	•		4/4	Corelis
56L811	TQFP	AP	•	•		4/5	Corelis
<b>Motorola 68HCXX</b>							
68HC11F1	PLCC	AP	•	•		3/4	ET
68HC11KA2	PLCC	AP	•	•		3/4	ET
68HC11K4	PQFP	AP	•	•		2/5	ET
68HC12A4	TQFP	AP	•	•		3/6	ET
68HC12B32	PQFP	AP	•	•		3/4	ET
<b>NEC</b>							
V25	PLCC	AP	•	•		3/5	ET
V830	TQFP	AP	•	•		5/6	Corelis
Vr4100	TQFP	AP	•	•		6/6	Corelis
Vr4111	µBGA	AP	•	•		6/6	Corelis
Vr4200	PQFP	AP	•	•		6/7	Corelis
Vr4300	PQFP	AP	•	•		4/4	Corelis
R5000	PGA	AP	•	•		6/9	Corelis
Vr5432	PQFP	AP	•	•		6/8	Corelis
Vr5464	BGA	AP	•	•		8/12	Corelis
<b>PACE</b>							
1750	PGA	AP	•			3/3	Lital
<b>QED</b>							
RM5230	PQFP	AP	•	•		6/7	Corelis
RM5260/61	PQFP	AP	•	•		6/11	Corelis
RM5270/71	BGA	AP	•	•		6/12	Corelis
RM7000	BGA	AP	•	•		6/12	Corelis
<b>Siemens</b>							
80C165	PQFP	AP	•	•		3/7	ET
80C166	PQFP	AP	•	•		3/8	ET <sup>5</sup>
80C167	PQFP	AP	•	•		4/9	ET
80C515	PLCC	AP	•	•		2/4	ET <sup>5</sup>
80C517/537	PLCC	AP	•	•		2/4	ET
<b>Texas Instruments</b>							
320C20/25	PGA	AP	•	•		3/3	Corelis
320C30	PGA	AP	•	•		4/7	Corelis
320C31	PQFP	AP	•	•		4/7	Corelis
320C32	PQFP	AP	•	•		6/6	Corelis
	TQFP	AP	•	•		6/6	Corelis
320C40	PGA	AP	•	•		5/16	Corelis
320C50/51/53	PQFP	AP	•	•		3/6	Corelis
320C52	PQFP	AP	•	•		4/4	Corelis
320C80	PGA	AP	•	•		-/8	Corelis
320C20X Family	IA	•	•			3/3	Corelis
320C24X Family	IA	•	•			3/3	Corelis
320C542/48/49	TQFP	AP	•	•		4/7	Corelis
370C16	—	IA	•	•		6/6	Corelis
470R1X	TQFP	IA	•	•		4/4	Corelis
<b>Toshiba</b>							
R3900	PQFP	AP	•	•		6/7	Corelis
TMPR1904	160-QFP	AP	•	•		6-8	E9599A #002
		ES <sup>4</sup>	•	•	•	6-8	E9499A #002
TMPR3901	160-QFP	AP	•	•		6	E9600A #002
		ES <sup>4</sup>	•	•	•	6	E9500A #002
TMPR3903	208-QFP	AP	•	•		6	E9601A #002
		ES <sup>4</sup>	•	•	•	6	E9501A #002
TMPR3904	208-QFP	AP	•	•		6-8	E9602A #002
		ES <sup>4</sup>	•	•	•	6-8	E9502A #002
TMPR1904, 3901/3/4	All	EP <sup>4</sup>					E5900A #800
		EM <sup>4</sup>					E5901A #800
		EMG <sup>4</sup>					E5902A #800
<b>Xilinx LCA</b>							
XC4005/4006	156-PGA	AP	•	•		-/8	Corelis
XC4008/4010	191-PGA	AP	•	•		-/8	Corelis

<sup>4</sup> Debuggers are available from third-party vendor(s). See page 459

<sup>5</sup> Contact vendor for pricing information.

Device Manufacturer and Name	Package Type	Prod Type	State	Timing	Emulation	Min#/ Max# Pods	Product or Channel Partner
<b>Standard Buses</b>							
AGP2X	N/A	AP		•		4/4	FuturePlus
AGP4X	N/A	AP	•			12	FuturePlus
APIC	N/A	AP	•	•		2-4	E2467A
Compact PCI/Ext	N/A	AP	•	•		4-7	FuturePlus
Direct Rambus	N/A	AP	•				FuturePlus
Fibre Channel	N/A	AP	•			4-8	FuturePlus
I2C	N/A	AP	•	•		2/2	ALD <sup>1,2</sup>
IBM ISA (AT)	N/A	AP	•	•		6/6	Corelis
IBM ISA (AT)	N/A	AP	•	•		5/5	Lital
IEEE 488 (HPIB)	N/A	AP	•	•		1/2	ALD
IEEE 1284	N/A	AP	•	•		2/2	ALD
IEEE 1394	N/A	AP	•	•		4-6	FuturePlus
JTAG 1149.1	N/A	AP	•	•		1/1	Corelis
JTAG 1149.5	N/A	AP	•	•		1/1	Corelis
PCI-64	N/A	AP	•	•		4-6	FuturePlus <sup>1,3</sup>
PCI/EXT-32	N/A	AP	•	•		4/4	FuturePlus
PCI/EXT-64	N/A	AP	•	•		4-6	FuturePlus <sup>1,3</sup>
PCI-32/Extender	N/A	AP	•	•		4/4	Corelis

Device Manufacturer and Name	Package Type	Prod Type	State	Timing	Emulation	Min#/ Max# Pods	Product or Channel Partner
PCI-32/E	N/A	AP	•	•		6/6	Corelis
PCI-64/Extender	N/A	AP	•	•		6/6	Corelis
PCI Mezzanine (PMC)		AP	•	•		4/4	FuturePlus
PCI EIO	N/A	AP	•	•		4/4	FuturePlus
PCI Cardbus	N/A	AP	•	•		4/4	FuturePlus
PCI-X	N/A	AP				6/6	FuturePlus <sup>3</sup>
PCMCIA	N/A	AP				-/4	Mobile
RS232c,RS449	N/A	AP	•	•		2/2	ALD
SCSI 1,2,3	N/A	AP	•	•		2/4	FuturePlus
LVD SCSI (Ultra)	N/A	AP	•	•		2/4	FuturePlus <sup>3</sup>
Univ Serial Bus	N/A	AP	•	•		2-3	FuturePlus
VME64/VXI	N/A	AP	•	•		5-9	FuturePlus
168-pin DIMM	N/A	AP				-/6	FuturePlus <sup>3</sup>
72-pin SIMM	N/A	AP				-/4	FuturePlus

<sup>1</sup> Refer to publication #5966-4365E for additional information.

<sup>2</sup> Requires purchasing multiple products.

<sup>3</sup> Multiple products are available with varying prices.

<sup>4</sup> Debuggers are available from third party vendor(s). See this page.

<sup>5</sup> Contact vendor for pricing information.

### Complementary Vendor Support

#### Third Party Debugger Support

Debuggers from several companies can be used to control Agilent emulation probes and emulation modules. Connections to tools through familiar debugger interfaces provide access to emulation features so that in-circuit debugging becomes an extension of the software debugging process under way.

The debuggers (table at right) connect to emulation probes and emulation modules, providing support for a variety of processor architectures and real-time operating systems. Contact the Agilent Call Center in your region for detailed connection information.

#### Complementary Vendors

The following companies provide products that complement logic analyzers and emulation probes/modules. Agilent works closely with these companies to ensure quality products, but the vendor is responsible for functionality, pre-sales and post-sales support, and warranty. For companies listed below with a "Resell Code", their products are also available from Agilent Technologies Corporate Price List. For resale products, the Channel Partner is still responsible for functionality, pre-sales, post-sales, and warranty.

Processor Family	Debugger Vendors
ARM 7, 9 Thumb ARM 7,9-ETM	ARM, GHS, WindRiver ARM, GHS
IBM PPC4xx IBM PPC 6xx IBM PPC 7xx	Microtec/Mentor, SDS, WindRiver GHS, Microtec/Mentor, SDS, WindRiver GHS, Microtec/Mentor, SDS, WindRiver
Pentium and Pentium w/MMX Pentium II, Pentium Pro and Pentium II mobile	CAD-UL American Arium
Motorola MPC 5xx Motorola PPC 6xx Motorola PPC 7xx Motorola PPC 7400 Motorola MPC 8xx Motorola MPC 82xx CPU32 M-Core	GHS, Microtec/Mentor, SDS, WindRiver GHS, Microtec/Mentor, SDS, WindRiver GHS, Microtec/Mentor, SDS, WindRiver GHS GHS, Microtec/Mentor, SDS, WindRiver GHS, Microtec/Mentor, SDS, WindRiver GHS, Microtec/Mentor, SDS SDS, GHS
Toshiba Tx19139	GHS

**ADVANCED LOGICAL DESIGN**  
Premier Channel Partner  
(Re-sell Code ALO)  
Ph 408-446-1004  
Fax 408-446-1079  
<http://www.ald.com>

**AMERICAN ARIUM**  
Ph 714-731-1661  
Fax 714-731-6344  
<http://www.arium.com>

**APTIX CORPORATION**  
Ph 408-428-6200  
Fax 408-944-0646  
<http://www.aptix.com>

**ARM INC.**  
Ph 408-579-2200  
Fax 408-579-1205  
<http://www.arm.com>

**CAD-UL, INC.**  
Ph 480-945-8188  
Fax 480-945-8177  
<http://www.cadul.com>

**CORELIS, INC.**  
Premier Channel Partner  
(Re-sell Code CRL)  
Ph 562-926-6727  
Fax 562-404-6196  
<http://www.corelis.com>

**DS DIAGONAL SYSTEMS AG**  
Ph 41 1 905 60 60  
Fax 41 1 905 60 69  
<http://www.diagonal.com>

**EMULATION TECHNOLOGY INC.**  
Ph 408-982-0660  
Fax 408-982-0664  
<http://www.emulation.com>

**EUROPE TECHNOLOGIES**  
Ph 330 493 004 304  
Fax 330 493 004 301  
<http://www.europe-technologies.com>

**FUTURE PLUS SYSTEMS CORP.**  
Premier Channel Partner  
(Re-sell Code FSI)  
Ph 719-380-7321  
Fax 719-380-7362  
<http://www.futureplus.com>

**GREEN HILLS SOFTWARE, INC.**  
Ph 805-965-6044  
Fax 805-965-6343  
<http://www.ghs.com>

**IRONWOOD ELECTRONICS, INC.**  
Ph 651-452-8100  
Fax 651-452-8400  
<http://www.ironwoodelectronics.com>

**J M ENGINEERING**  
Ph 719-591-1119  
Fax 719-637-1777  
<http://www.jmcorp.com>

**LITAL ELECTRONICS, INC.**  
Ph 714-731-8123  
Fax 714-731-8170  
<http://www.lital.com>

**MICROTEC/MENTOR**  
Ph 408-436-1500  
Fax 408-436-1501  
<http://www.mentor.com/embedded>

**MOBILE MEDIA RESEARCH**  
Ph 510-657-4891  
Fax 510-657-4892  
<http://www.mobmedres.com>

**POMONA ELECTRONICS**  
Ph 909-469-2900  
Fax 909-629-3317  
<http://www.pomonaelectronics.com>

**SOFTWARE DEVELOPMENT SYSTEMS, INC.**  
Ph 630-971-5900  
Fax 630-971-5901  
<http://www.sdsi.com>

**SYNAPTI CAD, INC.**  
Ph 540-953-3390  
Fax 540-953-3078  
<http://www.syncad.com>

**WINDRIVER SYSTEMS**  
Ph 510-748-4100  
Fax 510-749-2010  
<http://www.windriver.com>

E5346A  
E5351A

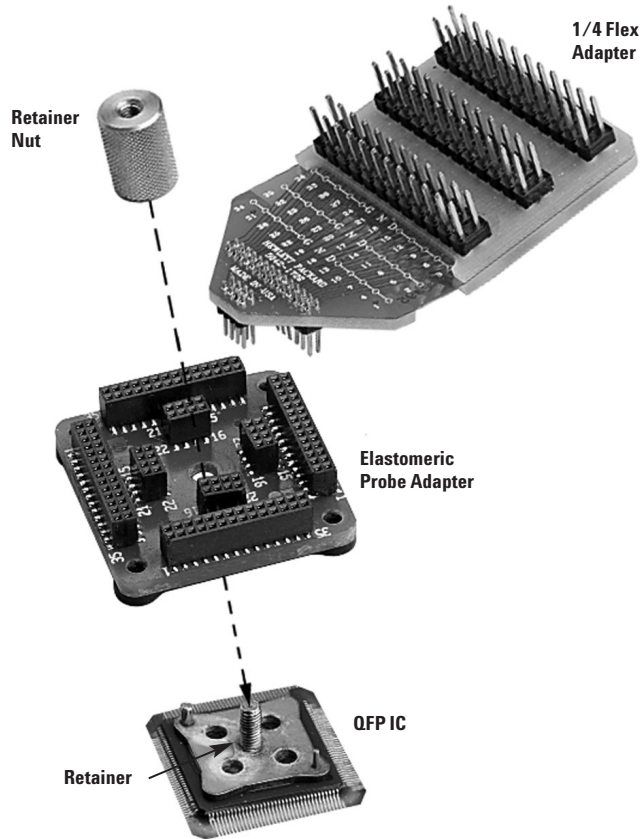

Agilent's elastomeric probe adapters offer a simple means of connecting to PQFP and TQFP packages with minimal "keep out" area.

10

## Reliable Measurements Start with Good Probing

Accurate measurements require reliable probing. Agilent's innovations in probing and accessories assure you of reliable measurements, while making it easy to connect the logic analyzer to your system.

Agilent's advances in probing minimize your concerns in the following areas:

- Keep out area
- Loading, both resistive and capacitive
- Ease of installation
- Reliability—mechanical and electrical

## We Make it Easy to Select and Order the Probes You Need

Agilent makes it easy for you to select the right probe for your needs. Most analysis probes come complete with all the accessories needed to complete the connection to your processor or bus.

For the latest information on all Agilent probes and accessories, visit our web site: <http://www.agilent.com/find/LAaccessories>

## Probing Alternatives

Probing Solution	Purpose
<b>MicroWedge, SMD Clips</b> .5 mm IC clips	Use this option if you are probing a few pins, or need to connect to PC boards/packages in hard-to-reach or already installed systems.
<b>High-Density Adapter Cable</b>	Provides a direct connection to 34 signals on an industry-standard connector. Use this approach if you are beginning to lay out a board and need to access custom parts or buses in your system, or are using BGA packages.
<b>Elastomeric Probing</b>	Agilent's patented elastomeric probing technology is ideal for low intrusion, easy and reliable connection to today's PQFP and TQFP packages.

## Wedge Probe Adapter

The Agilent Wedge provides an accurate, mechanically non-invasive way to make contact with IC pins with spacing of 0.65 or 0.5 mm. You can connect logic analyzer general purpose leads directly to the adapter or connect scope probes through a dual-head adapter.

## High-Density Adapters

The E5346A and E5351A high-density adapters provide a convenient and easy way to connect an Agilent logic analysis system to the signals on your target system. With difficult packages to probe, such as BGA, or with other probing restrictions, the adapters provide a high-density logic analysis connection that gives you access to multiple signals with minimal board space.

## Elastomeric Probing Solutions

An elastomeric probing solution from Agilent offers you an inexpensive, rugged, and easy-to-use probing solution for both TQFP and PQFP packages. These probes require a minimal "keep out" area around the device.

The elastomeric probe makes contact to the pins of a device with an elastomer material. There are redundant connections for each pin, ensuring a reliable and rugged connection. A retainer is glued to the top of the device to ensure a solid connection to each pin of the device.

## Termination Adapter

The 01650-63203 termination adapter allows you to use 3M 2x10 connectors in your system for connection to an Agilent logic analysis system. The termination is located at the probe tip of the adapter for easy application. Each connector is used for 16 data channels and one clock.



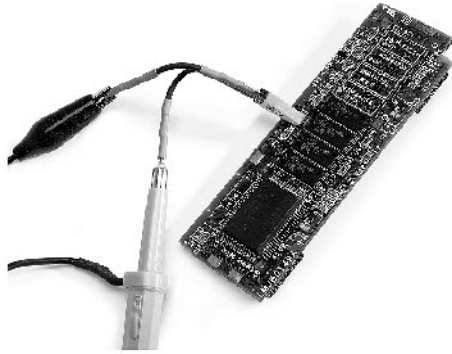

The MicroWedge probe adapter provides mechanically sound, non-invasive connection to three adjacent pins on TQFP and PQFP packages.

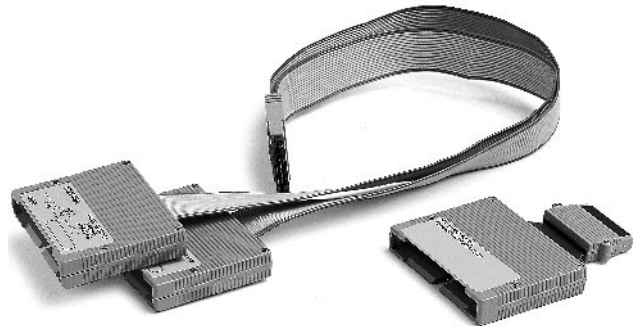

The E5346A high-density termination adapter provides access to 34 signals per connector; the standard termination adapter (01650-63203) provides 17.

### Probing Solutions

Package Type	Pin Pitch	Elastomeric Solutions
<b>240-Pin PQFP/CQFP</b>	0.5 mm	E5363A Probe Adapter E5371A 1/4 Flexible Adapter
<b>208-Pin PQFP/CQFP</b>	0.5 mm	E5374A Probe Adapter E5371A 1/4 Flexible Adapter
<b>176-Pin PQFP</b>	0.5 mm	E5348A Probe Adapter E5349A 1/4 Flexible Adapter
<b>160-Pin QFP</b>	0.5 mm	E5377A Probe Adapter E5349A 1/4 Flexible Adapter
<b>160-Pin PQFP/CQFP</b>	0.65 mm	E5373A Probe Adapter E5349A 1/4 Flexible Adapter
<b>144-Pin PQFP/CQFP</b>	0.65 mm	E5361A Probe Adapter E5340A 1/4 Flexible Adapter
<b>144-Pin TQFP</b>	0.5 mm	E5336A Probe Adapter E5340A 1/4 Flexible Adapter

### Key Literature

Probing Solutions for Agilent Logic Analysis Systems, p/n 5968-4632E  
 Processor and Bus Support for Agilent Logic Analysis Systems,  
 p/n 5966-4365E

### Ordering Information

#### High-Density Adapters

- E5346A** High-Density Termination Adapter
- E5351A** High-Density Adapter
- E5346-44701** Recommended Support Shroud
- E5346-60002** High-Speed Mictor Break-Out Adapter
- E5346-68701** Five Mictor Connectors and Support Shrouds

#### Termination Adapters

- 01650-63203** Standard Termination Adapter

#### Wedge Probe Adapters

- E2613A** (1) Wedge 0.5 mm Probe Adapter – 3 Signal
- E2613B** (2) Wedge 0.5 mm Probe Adapter – 3 Signal
- E2614A** (1) Wedge 0.5 mm Probe Adapter – 8 Signal
- E2615A** (1) Wedge 0.65 mm Probe Adapter – 3 Signal
- E2615B** (2) Wedge 0.65 mm Probe Adapter – 3 Signal
- E2616A** (1) Wedge 0.65 mm Probe Adapter – 8 Signal

1184A  
1540-1066

- Keyboard tray with adjustable tilt and height
- Mouse extension on keyboard tray accommodates either right or left hand operation
- 16700 frame and 16701 expansion frame can be located in the bottom of the cart, leaving the top free to accommodate a monitor
- Locking casters for safety on uneven surfaces
- Strap provided to stabilize the monitor
- Will hold up to 300 lbs. of equipment

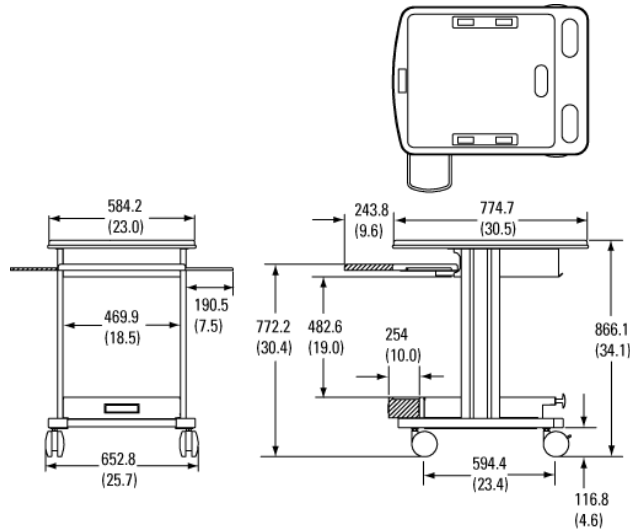

1184A testmobile cart dimensions. Dimensions: mm (inches).



Sturdy testmobile design gives your logic analyzer mobility and frees up bench space.

Make your logic analysis system a portable one with the Agilent testmobile. Each testmobile is designed to withstand rugged use.

### Ordering Information

**1184A** Testmobile

The 1540-1066 soft carrying case allows you to easily carry your Agilent 1670 series benchtop logic analyzer and its accessories to remote sites.

### Ordering Information

**1540-1066** Logic Analyzer Soft Carrying Case

### Verification Tools & Solutions

PCI Timing Check using the E2920 PCI Series Exerciser/Analyzer, Application Note  
[5968-5816E](#)

Agilent Network Server Division stabilizes server designs quickly and completely with E2920 PCI series, Case Study  
[5968-6948E](#)

Agilent HSTC speeds high end server testing and reduces engineering costs with E2920 PCI series, Case Study  
[5968-6949E](#)

Agilent E2920 Verification Tools, PCI Series gives Altera Corporation competitive advantage, Case Study  
[5968-4191E](#)

To download the above, please visit:

[www.agilent.com/find/pci\\_overview](http://www.agilent.com/find/pci_overview)

### Characterization Tools & Solutions

8114A Pulse Testing 980-nm Pump Laser-Diodes in Optical Fibre Amplifiers  
[5963-6988E](#)

81200 Data Generator/Analyzer Platform, Brochure  
[5980-0488E](#)

81200 Data Generator/Analyzer Platform, Technical Specifications  
[5965-3415E](#)

E4839A Test Fixture, Technical Specifications  
[5968-3580E](#)

BestLink/81200 Simulation Data Link for the 81200 Data Generator/Analyzer Platform, Product Information  
[5968-2548E](#)

(PN) How to Transfer Data between Design, Simulation and the 81200 Data Generator/Analyzer Platform  
[5967-6276E](#)

(PN) Flat Panel Display Link Test  
[5968-8028E](#)

(PN) How to Use the 81200 Data Generator/Analyzer Platform Together with Agilent VEE for Signal Integrity Analysis  
[5968-3857E](#)

(PN) Measuring Jitter with the E4874A Characterization Software Components  
[5968-6033E](#)

(PN) Radar Distance Test to Airborne Planes  
[5968-5843E](#)

(PN) The Dual Clock Gbit Chip Test  
[5968-5844E](#)

(PN) Magneto-Optical Disk Drive Research  
[5968-5845E](#)

(PN) Simulation of Jittering Synchronization Signals for Video Interfaces  
[5968-5846E](#)

(PN) E6280A PNNI Signalling Test Software for the Broadband Series Test System  
[5965-9079E](#)

## Agilent's web site: Get news, updated product and support information, and more, 24 hours a day.

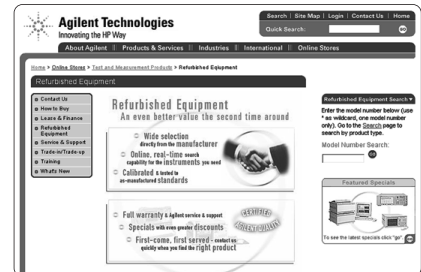
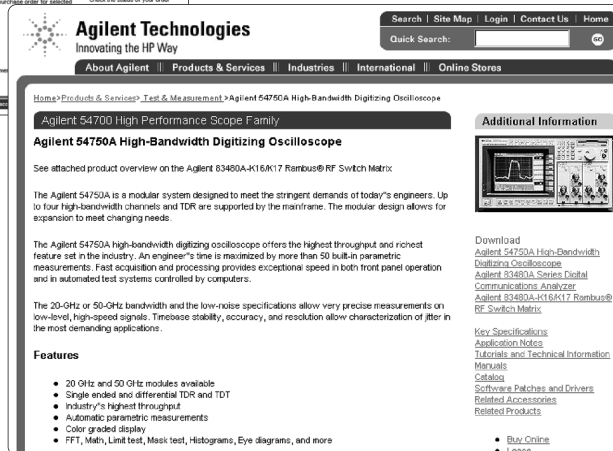

### Resources Available Online

- Product and support information more easily with helpful navigation aids and improved web pages that make it easier to access application notes, product overviews, technical details, frequently asked questions, manuals, software, news releases, education course descriptions and schedules, and much more.

- Updated comparison data and evaluation guides/tools that facilitate product selections
- Helpful application notes, downloadable interactive application notes, tutorials, online models, and other learning and problem-solving material
- Quick access to customer support services
- Information on recommended replacements for discontinued products
- Information in your local language\*
- The latest information on the status of your Agilent test and measurement order

### Take Action

- Selected Agilent products—including scopes, logic analyzers, EDA software, multimeters, data acquisition products, signal sources, counters, power supplies, and more\*
- Refurbished instruments\*
- Accessories\*
- Replacement parts\*

For more information on the test and measurement features, resources, and services available on Agilent's web site, see page 3.

Use our online test and measurement resources and services often!  
[www.agilent.com/find/tmc](http://www.agilent.com/find/tmc)

\*Availability of this feature may be limited; an expansion program is ongoing. Online purchases require a credit card.

For best results, view the Agilent web site with Microsoft's Internet Explorer browser.



<b>Optical Component Test</b>	466
<b>Spectrum Analyzers</b>	472
<b>Optical Wavelength Meters</b>	473
<b>CD Test Solutions &amp; Polarization Analyzers</b>	474
<b>Digital Communication Analyzers</b>	475
<i>See also</i> Oscilloscopes 106	
<b>Lightwave Converters &amp; Signal Analyzers</b>	477
<b>Component Analyzers</b>	478
<b>Additional Literature</b>	479

8164A

- Mode-hop free tuning at continuous power
- Built-in wavelength control loop
- Output power up to +8 dBm
- Ultra low source spontaneous emission output



8164A

### The 8164A—A New Platform for the Test of Fiber Optic Components

The 8164A Lightwave Measurement System supports a whole range of tunable laser modules and all modules of the 8153A and 8163A Lightwave Multimeter series. The 8164A mainframe features connectivity to a wide range of controlling equipment through GPIB and PC Card interface. Configurable hardware input and output trigger ports complete the 8164A's ability to operate in an automated test environment. A 3.5" floppy drive, VGA port (a RS232C serial interface), keyboard connector, and parallel printer port are included.

- Tunable lasers for all gain bands.
- The 81680A and 81682A modules operate in the 1550 nm band whereas the 81640A covers the wavelength range from 1510 nm to 1640 nm.
- Optimum tuning precision for the test of critical dense-WDM devices.

The 81640A, 81680A and 81682A Tunable Laser modules with their built-in wavelength control loop push today's performance limits. As they are all mode-hop free tunable with continuous output power, they qualify for the test of the most critical DWDM components. All three modules fit into the bottom slot of the 8164A mainframe.

### Polarization Maintaining Fiber for the Test of Integrated Optical Devices

The 81640A, 81680A and 81682A modules are ideally constructed to characterize integrated optical devices. Their Panda PMF output ports provide a well-defined state of polarization to ensure constant measurement conditions. A PMF cable easily connects an external optical modulator.

### Low Spontaneous Emission for Maximum Measurement Range

The 81640A and 81680A tunable laser modules are equipped with two optical outputs. One output port delivers a signal with ultra-low source spontaneous emission (SSE). It enables accurate crosstalk measurement of dense-WDM system components with many channels at narrow spacing. A power meter module alone is sufficient to characterize steep notch filters such as Fiber Bragg Gratings.

The second output port provides increased optical power and allows adjustment by more than 60 dB through a built-in optical attenuator.

### Test of Optical Amplifiers and Passive Components

The 81682A Tunable Laser module provides the high stimulus power needed to test today's optical amplifiers. An optional, built-in optical attenuator allows an output power dynamic of more than 60 dB. Its excellent wavelength precision makes it a multi-purpose instrument for all kinds of component test.

### Compact Module for Multichannel Test

A variable amount of the compact, yet fully remote controlled 81689A Tunable Laser modules, in combination with the 81682A high power Tunable Laser, is the ideal solution to characterize optical amplifiers for use in dense-WDM applications. Furthermore the 81689A allows a realistic multi-channel test bed for dense WDM transmission systems to be set up.

Its continuous, mode-hop free tuning makes it quick and easy to set even the most complex configurations to the target wavelengths and power levels, just by dialing or using the vernier keys. The 81689A is available with both standard single-mode fiber and Panda-type PMF.

Each 8164A mainframe can host up to four units of the 81689A in its upper slots. The 8166A Lightwave Multichannel System mainframe, however, allows you to combine up to 17 of the compact tunable laser modules in a single frame and more than one mainframe can easily be controlled if needed.

### Smart Tunable Loss Test Set

Inserted into the 8163A Lightwave Multimeter mainframe, together with a power meter module the 81689A compact tunable laser forms a smart, portable loss test set. Its tunability allows devices and links, at all wavelengths, in the EDFA window to be checked.

### Built-in Application for Quick Evaluation of Filters and Other Devices with up to 8 Output Ports:

Revisions 2.0 and later of the 8164A instrument firmware enable synchronous measurement of the insertion loss at up to 8 device ports in wavelength sweeping mode. The application includes trace display, markers and data storage.

### Specifications

Specifications describe the instrument's warranted performance. They are measured at the end of a 2 m long patchcord and are valid for the output power and wavelength ranges as stated below. Supplementary performance characteristics provide information about non-warranted instrument performance in the form of nominal values, and are printed in italic typeface.

	<b>81680A</b>	<b>81640A</b>	<b>81682A</b>	<b>81689A</b>
<b>Primary Application</b>	To-the-limits-test of critical DWDM components	Test of critical components in both DWDM bands	Test of critical amplifiers and passive components	Multiple channel test of optical amplifiers and transmission systems, compact form factor
<b>Wavelength Range</b>	1460 to 1580 nm	1510 to 1640 nm	1460 to 1580 nm	1525 to 1575 nm
<b>Absolute Wavelength Accuracy</b>	± 0.01 nm	± 0.015 nm	± 0.01 nm	± 0.3 nm, typical
<b>Relative Wavelength Accuracy</b>	± 5 pm (± 2 pm, typical)	± 7 pm (± 3 pm, typical)	± 5 pm (± 2 pm, typical)	± 0.3 nm
<b>Wavelength Resolution</b>	0.1 pm	0.1 pm	0.1 pm	10 pm
<b>Signal to Source Spontaneous Emission Ratio</b>	63 dB/ nm (output 1) 45 dB/ nm (output 2)	60 dB/ nm (output 1) 45 dB/ nm (output 2)	45 dB/ nm	39 dB/ nm, typical
<b>Signal to Total Source Spontaneous Emission Ratio</b>	60 dB (output 1) 30 dB (output 2, typical)	55 dB (output 1) 27 dB (output 2, typical)	30 dB, typical	–
<b>Maximum Output Power</b>	–6 dBm (output 1) +5 dBm (output 2) (1520–1570 nm)	–7 dBm (output 1) +2 dBm (output 2) (1530–1610 nm)	+6 dBm (1520–1570 nm)	+6 dBm (1525–1575 nm)
<b>Maximum Output Power (Peak, Typical)</b>	–4 dBm (output 1) +6 dBm (output 2)	–5 dBm (output 1) +4 dBm (output 2)	+8 dBm	–

For further details, please contact your Agilent representative and ask for literature number 5968-0063E (technical specifications).

### Ordering Information

**8164A** Lightwave Measurement System (mainframe)

**8166A** Lightwave Multichannel System (mainframe)

**81640A** Tunable Laser Module, ±3 pm, Low SSE, 1600 nm<sup>a</sup>

**81645A** Filler Module

**81680A** Tunable Laser Module, ± 2 pm, Low SSE, 1550 nm<sup>b</sup>

**81682A** Tunable Laser Module, +8 dBm, 1550 nm<sup>a</sup>

**Option 003** Built-in Optical Attenuator with 60 dB attenuation range (available with 81682A only, reduces max. output by 1.5 dB)

**81689A** Compact Tunable Laser Module, +6 dBm, 1550 nm<sup>a</sup>

Tunable laser must be ordered with one connector option:

**Option 021** Single mode fiber, straight contact connector (available with 81689A)

**Option 022** Single mode fiber, angled contact connector (available with 81689A)

**Option 071** Polarization Maintaining Fiber, straight contact connector

**Option 072** Polarization Maintaining Fiber, angled contact connector

<sup>a</sup>one Series 81000xl Connector Interface is required; see page 469

<sup>b</sup>two Series 81000xl Connector Interfaces are required; see page 469

### 816x VISA VXIplug&play Driver

#### Best-in-Class Measurement Equipment for Fast and Accurate Test of Critical Dense-WDM Devices.

The Agilent 8164A Lightwave Measurement System, together with the 8166A Lightwave Multichannel System, a whole range of tunable lasers, and the series 8162 and 8163 power heads and sensor modules, enables fast and accurate test of passive optical components. Offering industry leading measurement accuracy and dynamic range, they let you choose from a whole scale of solutions with outstanding performance, small footprint, and an excellent price-performance ratio.

Using the new, powerful 816x VISA VXIplug&play Driver, these instruments are quickly and easily set up for automated measurements in high-volume manufacturing.

Even devices with a high port count, such as DWDM multiplexers and demultiplexers can be fully evaluated within a few moments.

#### Built-in Application for Quick Evaluation of Filters and Other Devices with up to 8 Output Ports:

In addition, revisions 2.0 and later 8164A instrument firmware enable synchronous measurement of the insertion loss over wavelength at up to 8 device ports. The same is possible on the 8163A Lightwave Multimeter at up to 2 device ports. The application includes trace display, markers print out, and data storage.

#### Easy-to-Use VISA VXIplug&play Driver for Faster, Trouble-free Test Implementation

As setting up today's increasingly complex, highly automated test solutions turns out to be a major effort, Agilent's new VISA VXIplug&play Driver takes load off test and software engineers' aggressive shoulders.

The driver integrates multiple GPIB commands into single, easy-to-understand functions, e.g., for the acquisition of a component's loss over wavelength, saving implementation time and reducing the complexity of the test programs. Built-in error handling and parameter checking, as well as the comprehensive online help, lead to success earlier and help to avoid mistakes. It even allows the programming of complex tasks without intimate knowledge of individual GPIB commands.

The 816x VISA VXIplug&play Driver activates the tunable laser's built-in wavelength logging capability and thus enables a wavelength accuracy, linearity, and repeatability that comes close to the performance in static operation. Similarly, the 816x VISA VXIplug&play Driver has built-in expert knowledge on the trigger and sampling behavior of the series 8162 and 8163 power heads and sensor modules, which relieves programmers from studying hardware details.

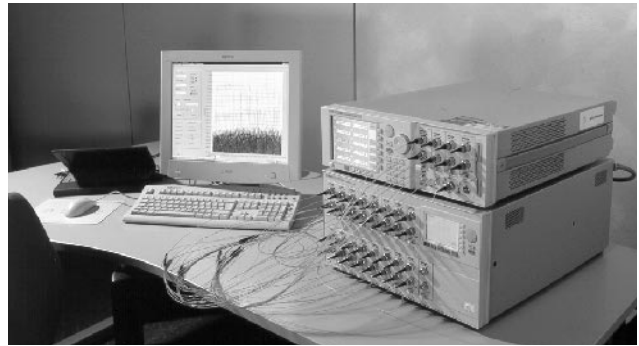

816x VISA VXIplug&play driver

#### Supported Programming Environments

For sophisticated user interfacing, the 816x VISA VXIplug&play Driver seamlessly integrates into Agilent VEE and National Instruments LabVIEW and Lab Windows graphical programming environments, allowing you to enhance productivity and efficiency of the test implementation.

Furthermore, the 816x VISA VXIplug&play Driver can be easily integrated with C, C++ and VisualBasic.

Programming examples, printable programming guide, and online help files are included with the driver setup program on the product CD-ROM.

#### System Integration Services Available

Please refer to pages 67–68 for Agilent Technologies' Support and Services, if you require more custom test solutions.

#### Ordering Instructions

The Agilent 816x VISA VXIplug&play Driver is included on CD-ROM with the following Agilent instruments: 8163A, 8164A and 8166A. To obtain extra copies, please order the **08164-13601 Product CD-ROM**.

Please also check Agilent Technologies web sites for the most recent product updates, and for programming examples.

#### Key Literature

Agilent 816x VISA VXIplug&play Driver, fact sheet, p/n 5980-1453E  
State-of-the-art characterization of optical components for DWDM applications, application brief, p/n 5980-1454E

See pages 466, 469, and 470 for further information on the 8164A Lightwave Measurement System, the 8166A Lightwave Multichannel System, and the 8163A Lightwave Multimeter.





86060C Series Switches

### 86060C Series of Lightwave Switches



The 86060C series of programmable lightwave switches cover a broad range of switching capacity and provide easy signal routing for accurate and repeatable measurement automation for multimode (750–1350 nm) and singlemode (1280–1650 nm) testing. These switches provide an important building block for implementing automated testing and system configuration, and reducing test and setup times.

Agilent's switch family features an easy-to-use front panel interface with signal routing display, low insertion loss, and temperature stabilized performance. These switches can be easily integrated into automated test systems using SCPI-compatible commands via GPIB or RS-232 interfaces. Custom configurations, such as contiguous channels, blocking dual inputs, and multilayering, are available to meet specific customer needs.

For more complete information order the Lightwave Test and Measurement catalog. See detailed description on page 600.

### 83437A Broadband Light Source 83438A Erbium ASE Source

In conjunction with an OSA, the incoherent light sources 83437A and 83438A allow you to measure insertion loss, crosstalk, bandwidth, polarization dependencies, and other parameters of passive optical components versus wavelength.

Built to order, the 83437A can incorporate up to four edge-emitting LEDs (EELEDs) per box, with seven available wavelengths (980 nm, 1200 nm, 1310 nm, 1430 nm, 1550 nm, 1600 nm, and 1650 nm). The peak power density of each EELED in a single-mode fiber is more than 25 dB stronger than that of a white light source.

The 83438A provides more than +6 dBm in the 1530–1570 nm window, allowing you to characterize advanced components such as isolators, circulators, add/drop multiplexers, gratings, or demultiplexers for dense wavelength-division multiplexing (DWDM) systems. Both the 83437A and 83438A provide a low cost, small footprint solution to meet your testing needs.

For more complete information, order the Lightwave Test and Measurement Catalog. See detailed description on page 600.

- Minimizes test cost
- Increases throughput
- Saves rack space

86060C  
Series  
83437A  
83438A  
8166A

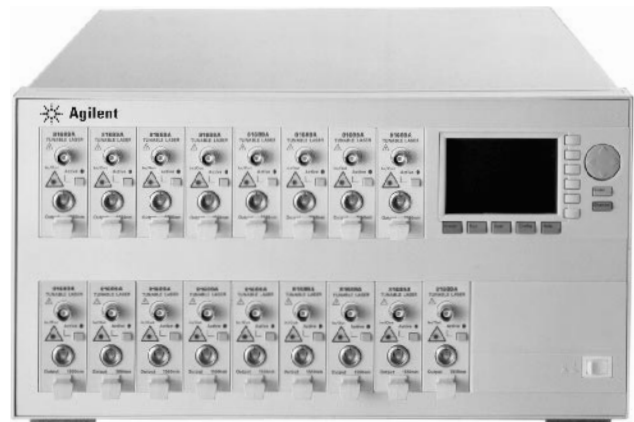

The 8166A—Lightwave Multichannel System—Stimulus-Response Solutions

### 8166A Lightwave Multichannel System

The 8166A Lightwave Multichannel System is a base system with 17 slots for plug-in modules of the 8163A Lightwave Multimeter series. All these modules can be used in any configuration.

The compact form and small footprint of this system saves valuable rack or bench space and gives an excellent price/performance ratio per channel.

### The Ideal System for Manufacturing and Research & Development

In manufacturing, the 8166A Lightwave Multichannel System helps to increase throughput with its fast, simultaneous and synchronized measurement capabilities.

R&D engineers will value the quick multichannel or system characterizations, as well as easy troubleshooting. The 8166A Lightwave Multichannel System is a versatile tool for accelerated multiple stimulus/response measurements at fixed or at variable wavelengths.

### Key Literature

Product Overview, p/n 5968-3406E  
Technical Specifications, p/n 5968-3940E

### Ordering Information

8166A Lightwave Multichannel System

- Variety of plug-in modules for optimized set-ups
- Power meters at lowest PDL and spectral ripple
- Output power of laser sources (FP) up to 13 dBm
- ITU channel sources (DFB) with high precision
- Optimized return loss solutions



### The 8163A—Modular Stimulus-Response Solutions with Excellent Performance

The 8163A Lightwave Multimeter is a basic measurement tool in the fiberoptic industry. It ensures accurate and fast results even for the most demanding measurements on optical components and systems.

Its modular format makes it flexible enough to meet changing measurement needs whether measuring optical power, insertion loss or return loss for single- or multimode components.

#### Precise, Sensitive, Stable and Fast Power Measurements

Four different power sensor modules and three external power sensors (optical heads) cover the important wavelengths and power ranges. Thanks to the excellent accuracy, high linearity and low polarization dependent loss (PDL) best measurement results are ensured. The measurement speed can come down to 200 $\mu$ s, which further optimizes the power measurements. Each power sensor and each optical head is individually calibrated over its wavelength range and is traceable to NIST and German PTB for precise optical power measurements.

A broad variety of advanced interfaces and adapters make it easy to connect the test devices.

#### Stable Fixed Laser Source Modules

The source modules are stabilized for short and long term applications and are also not sensitive to backreflections. There is a choice of single and dual wavelength source modules, available with an output power of up to 13 dBm. The output power can be attenuated by up to 6 dB. All source modules are able to output CW or pulse-modulated light (internal modulation 270Hz to 10kHz).

For DFB source modules please refer to the ordering guide to select the appropriate wavelength.

#### Compact Tunable Laser Source Modules

These modules enable measurements at freely selectable fixed wavelengths or allow characterization of the test device as a function of wavelength. One compact tunable laser module and one single or dual power sensor can be hosted in the 8163A Lightwave Multimeter mainframe. This set-up is a compact and complete solution for wavelength dependent loss measurements.

The compact tunable laser module offers continuous, mode-hop free tuning, and is set quickly and easily to the target wavelengths and power levels, even for the most complex configurations, just by using the vernier keys. The compact tunable laser modules are available with both standard single-mode fiber and Panda-type PMF.

#### Return Loss Solutions

The return loss modules offer high precision and high accuracy for the best possible measurements. In addition the return loss modules give the convenience of self-calibration, when speed is of the essence, due to the excellent stability of the built-in laser source.

#### Compatibility

The 8163A Lightwave Multimeter mainframe is compatible with the modules from its successful predecessor, the 8153A Lightwave Multimeter series. Also both the modules of the 8163A series and the 8153A series can be used together in the 8163A mainframe.

The programming syntax used by the 8153A Multimeter is compatible with the 8164A Lightwave Measurement System (the tunable laser mainframe) the 8166A Lightwave Multichannel System and with the 8163A Lightwave Multimeter.

#### Key Literature

8163A Lightwave Multimeter, Product Overview, p/n 5968-3404E  
 Configuration Guide, p/n 5968-3581E  
 Technical Specifications, p/n 5968-3940E

#### Ordering Information

The 8163A Mainframe has two slots for any combination of the modules listed or modules of the 8153A Lightwave Multimeter series. Connector interfaces should be ordered for each input and output. The 8163A supports a wide range of fiber connectors. For details please refer to the 8163A Configuration Guide. Optical heads require an interface module 81618A (single) or 81619A (dual).

##### Mainframe

**8163A** Lightwave Multimeter Mainframe

##### Power sensor modules

**81632A** InGaAs, +10dBm to -80dBm, 800 to 1650nm

Opt 001  $\pm$  0.015 polarization sensitivity

**81635A** (dual sensor) InGaAs, +10dBm to -80dBm, 800 to 1650nm

**81633A** InGaAs, +10dBm to -90dBm, 800 to 1700nm

**81634A** InGaAs, +10dBm to -110dBm, 800 to 1700nm

##### Optical heads

**81623A** Ge, +10dBm to -80dBm, 750 to 1800nm

**81624A** InGaAs, +10dBm to -90dBm, 800 to 1700nm

**81625B** InGaAs, +27dBm to -80dBm, 850 to 1650nm

##### Source modules 0 dBm (Fabry Perot)

**81650A** 1310nm, single mode

**81651A** 1550nm, single mode

**81652A** 1550/1625nm, single mode

**81653A** 1650nm, single mode

**81654A** 1310/1550nm, single mode

##### Source modules 13 dBm (Fabry Perot)

**81655A** 1310nm, single mode

**81656A** 1550nm, single mode

**81657A** 1310/1550nm, single mode

##### Compact tunable source module

**81689A** 1525 to 1575nm, 6dBm

##### DFB source modules

**81662A**

##### Return loss modules

**81610 A** InGaAs, no internal source, dynamic range 70dB

**81611A** InGaAs, 1300nm, dynamic range 75dB

**81612A** InGaAs, 1550nm, dynamic range 75dB

**81613A** InGaAs, 1310/1550nm, dynamic range 75dB

**81614A** InGaAs, 1550/1625nm, dynamic range 75dB

- 0.05 dB attenuation accuracy, 0.001 dB resolution
- 0.02 dBp-p polarization sensitivity
- Optional monitor output
- Back reflector mode

- $\pm 0.002$  dB insertion loss variation with adjustment (11896A)
- 1250 nm to 1600 nm coverage (11896A)
- Synthesis of states of polarization (8169A)

8156A  
11896A  
8169A

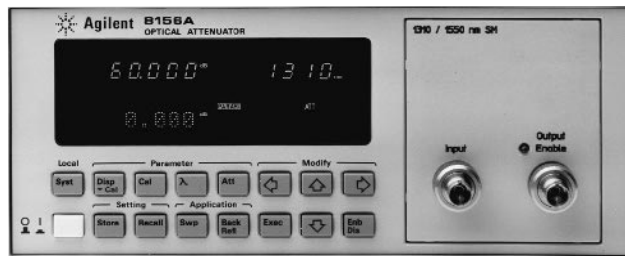

8156A



11896A and 8169A

### 8156A Attenuator



The 8156A is a high performance attenuator for single-mode and multimode applications.

Options are available to select the desired return loss performance (up to 60 dB). An optional 13 dB monitor output allows you to measure the signal power at the output of the attenuator. Using the built-in back reflector mode and an external reference reflector (81000BR), the 8156A can be used as a programmable back reflector to measure component and system sensitivity against reflections.

The attenuation range is 60 dB with 0.001 dB resolution between 1200 nm and 1650 nm. Due to a novel single filter design, no ranging occurs. This completely eliminates dark spots or potential attenuation overshoots or undershoots. Attenuation accuracy is typically better than  $\pm 0.05$  dB with a polarization sensitivity of less than 0.02 dB peak-to-peak.

For more detailed information, see the *Lightwave Test and Measurement Catalog*.

### Specifications

	8156A Opt 100	8156A Opt 101/201	8156A Opt 121/221	8156A Opt 350
<b>Wavelength range</b>	1200 to 1650 nm			
<b>Fiber type</b>	single-mode			50 $\mu$ m multimode
<b>Attenuation range</b>	60 dB			
<b>Resolution</b>	0.001 dB			
<b>Return loss</b>	>35 dB	>45 dB/>60 dB	>45 dB/>60 dB	>22 dB
<b>Insertion loss (typical)<sup>1</sup></b>	4.5 dB	2.5 dB	3.3 dB	3.0 dB
<b>Attenuation accuracy (typical)</b>	$\pm 0.1$ dB	$\pm 0.05$ dB	$\pm 0.05$ dB	$\pm 0.08$ dB
<b>Polarization sensitivity (typical)</b>	<0.075 dBp-p	<0.02 dBp-p	<0.03 dBp-p	—
<b>Repeatability (typical)</b>	$\pm 0.005$ dB			
<b>Switching time</b>	20–400 ms			
<b>Maximum input power</b>	+23 dBm			

<sup>1</sup>Includes insertion loss of two HMS-10 connectors.

**Size:** 89 mm H x 212.3 mm W x 345 mm D (3.5 in x 8.36 in x 13.6 in)  
**Weight:** Net, 5.3 kg (11.7 lb); shipping, 9.6 kg (21.2 lb)

### Ordering Information

Two connector interfaces (three for Option 121/221) are required for each 8156A

- 8156A** Optical Attenuator Mainframe  
**Opt 100** Standard Performance Version  
**Opt 101** High Performance Version  
**Opt 121** Monitor Output, 45 dB Return Loss  
**Opt 201** High Performance, High Return Loss Version  
**Opt 203** Back Reflector Kit for Option 201\*  
**Opt 221** Monitor Output, 60 dB Return Loss  
**Opt 350** 50/125  $\mu$ m Multimode

**81000AI/FI/GI/KI/NI/PI/SI/VI/WI** Connector Interfaces

\* Kit consists of one each: 81000SI, 81000FI, 81113PC, 81000UM, and 81000BR.

### 11896A Polarization Controller



The 11896A adjusts polarization and not power. Its optical fiber loop design provides all states of polarization with extremely small optical insertion-loss variations ( $\pm 0.002$  dB) over a wide spectral range (1250 to 1600 nm) with low characteristic insertion loss (<0.03 dB to 1625 nm). This performance combination maximizes measurement accuracy for power-sensitive applications like polarization-dependent loss and gain, and minimizes measurement uncertainty. This compact, low-cost, high-accuracy instrument is ideal for polarization dependent loss (PDL) measurements. Custom configurations, such as 980 nm operation, are also available.

### 8169A Polarization Controller



The 8169A provides polarization synthesis relative to a built-in linear polarizer. The internal quarter-wave plate and half-wave plate are individually adjusted to create all possible states of polarization. Predetermined algorithms within the 8169A enable the transition path from one state of polarization on the Poincare sphere to another to be specified along orthogonal great circles. These features are important because device response data can be correlated to specific states of polarization input to the test device.

### Specifications

	11896A	8169A
<b>Operating Wavelength Range (nm):</b>	1250 to 1600	1470 to 1570
<b>Insertion Loss:</b>	<2.0 dB	<1.5 dB
<b>Variation with Adjustment:</b>	< $\pm 0.002$ dB	< $\pm 0.03$ dB
<b>Variation with Wavelength:</b>	< $\pm 0.1$ dB	< $\pm 0.1$ dB

Note: Fiber pigtail interface assumed in all cases.

### Key Literature

11896A and 8169A Technical Specifications, p/n 5962-0017E

### Ordering Information

- 11896A** Lightwave Polarization Controller  
 Standard instrument includes FC/PC connector interfaces  
**Opt 025** One Meter Pigtail Fiber w/ FC/PC Connector Interfaces  
**8169A** Lightwave Polarization Controller  
 (Polarization controller must be ordered with connector option)  
**Opt 020** Pigtailed Fiber Ports  
**Opt 021** Straight Contact Connector Output  
**Opt 022** Angled Contact Connector Output  
**81000AI/FI/GI/KI/NI/PI/SI/VI/WI** Connector Interfaces

86140B  
86141B  
86142B  
86143B  
86145B

- 10 pm wavelength accuracy and low polarization dependence
- 90 dBm sensitivity and 70 dB dynamic range
- Real time sweep speed rates and improved high-speed data transfer
- New flexible monochromator output model
- Applications with automatic pass/fail checking
- Benchtop and portable platforms
- Intuitive graphic user interface
- Integral floppy disk and printer
- Optional internal wavelength calibrator and EELED
- VGA and parallel (Centronics) interface
- Two-year calibration cycle

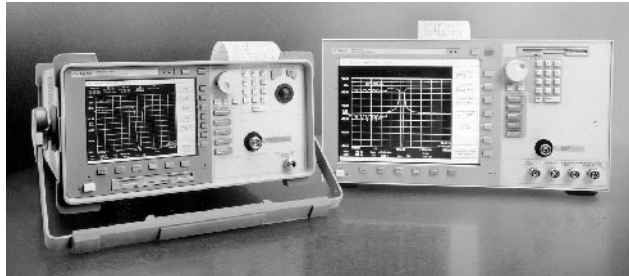

Optical Spectrum Analyzers

### 86140B, 86141B, 86142B, 86143B, 86145B Optical Spectrum Analyzers



The Agilent 86140B, 86141B, 86142B, 86143B, and 86145B are a family of grating-based optical spectrum analyzers that display the amplitude of light versus wavelength over a 600 to 1700 nm wavelength range. The OSA uses a patented double-pass monochromator design to simultaneously achieve high sensitivity and dynamic range with a fast sweep time. This is key for characterizing DWDM components and multiple channel systems, especially in a manufacturing environment where speed, accuracy, and throughput are critical.

The family consists of both benchtop (86140B, 86141B, and 86142B) and portable (86143B and 86145B) units that have integral printers and floppy disk drives to allow instant documentation of results and transfer of electronic copies to a PC. A VGA port allows a PC monitor to be connected directly to the OSA screen, and a parallel (Centronics) interface enables clear color copies of measurement results to be generated. The GPIB interface provides high transfer speeds across the bus which are critical in a high throughput environment. The uncluttered front panel has been designed to complement the intuitive graphical user interface (GUI) that has been significantly enhanced over the previous generation Agilent 71450 series optical spectrum analyzers. The interface can be driven either from the front panel or using an external pointing device.

	Benchtop OSA	Portable OSA
High Performance	86142B	86145B
Standard Performance	86140B	86143B
Flexible Performance	86141B	

### High Performance

The benchtop 86142B and portable 86145B analyzers are top of the range high performance units ideally suited to WDM applications where dynamic range and low polarization dependence are critical. In these units, many of the OSA high performance parameters have

been optimized to cover the EDFA extended wavelength bands (1525 nm to 1610 nm). This extended wavelength range also makes these OSAs ideal for testing WDM passive components (filters, multiplexers and Bragg Gratings), characterizing DWDM transmitter lasers and analyzing DWDM multi-channel system performance.

### Value Performance

The 86140B benchtop and 86143B portable optical spectrum analyzers maintain most of the high performance of the 86142B and 86145B, but are priced at a lower cost.

### Flexible Performance

The 86141B optical spectrum analyzer, with a monochromator output, is a versatile, benchtop OSA suitable for a wide variety of applications. It can be used as an optical spectrum analyzer, a tunable bandpass filter, or a power meter. In OSA mode, the 86141B can be used to characterize passive components or analyze WDM signals. In filter mode, the instrument can be used to isolate a particular WDM signal so that it may be further analyzed. In power meter mode, the 86141B can be used for tasks such as fiber alignment.

### Benchtop Platform

The benchtop OSA has a large, bright 10.4" active matrix color LCD display and can support a variety of EELED, white light source, and wavelength calibration options. This OSA is ideal for R&D and manufacturing environments where display clarity and ease of use are important.

### Portable Platform

The high performance portable platform has a small 32.5 cm × 43 cm (12.8 in × 16.8 in) footprint and weighs in at 14.5 kg (32 lb). This is designed for applications where space is at a premium and yet full optical spectrum analyzer capability (not offered by today's mini OSAs) is required. It also supports a wavelength calibration option. This makes the OSA ideal for both field and factory use, particularly in high level system installations or situations where bench space is limited. The portable unit has a high clarity 16.25 cm (6.4 in) active matrix LCD display.

### Built-in Applications

Agilent Technologies has developed a unique concept for built-in applications. These new applications enable the user to develop tests that can be customized to their particular passive device or WDM system. The user inputs the minimum and maximum specifications that their device or system must fall between. The OSA then performs tests based on these specifications, displaying a PASS or FAIL message for each specification tested, and highlighting any failed specifications. The results can be saved to a file or printed out on either the internal OSA printer or an external printer.

### Additional Features

The 86140B-series optical spectrum analyzers feature up to six traces and four independent markers. The built-in trace math function of the OSA allows for multiple traces to be used for normalization measurements. The markers allow for easy measurement of wavelength separation (GHz or nm), power density, and optical signal to noise ratio.

For more complete information, order the Lightwave Test and Measurement Catalog. See detailed description on page 600.



- Accurate characterization of WDM signals
- Simultaneously measure up to 200 wavelengths and powers
- Characterize Fabry-Perot lasers using the built-in automated measurement routine
- $\pm 2$  ppm wavelength accuracy
- 10 GHz wavelength resolution
- Signal-to-noise ratio measurements for tightly spaced WDM systems
- Channel drift measurements

- Up to 200 WDM channels characterized with single keystroke operation
- Unparalleled ruggedness
- $\pm 2$  ppm absolute wavelength accuracy
- Lightweight and portable
- Built-in printer and disk drive
- On-board serial and parallel interfaces

86120C  
86121A



86120C

### 86120C Multi-Wavelength Meter



#### R & D and Manufacturing Applications

The 86120C multi-wavelength meter allows you to accurately measure the average wavelength of the input signal. In addition, the Agilent multi-wavelength meter—with advanced digital signal processing—accurately and easily differentiates and measures up to 200 discrete wavelengths. This Michelson interferometer-based instrument can simultaneously measure the individual powers of the discrete wavelengths, offering the following measurement capabilities:

- 1 to 200 wavelengths and powers
- Average wavelength and total power
- 2 ppm wavelength accuracy (0.003 nm at 1550 nm)
- 10 GHz wavelength resolution
- Calibrated for elevation in air or vacuum
- Wavelength units in nm, THz, or wave number (cm<sup>-1</sup>)
- Amplitude units in dBm, mW, or  $\mu$ W
- SNR and averaged SNR for WDM SONET/SDH systems
- Rugged design to withstand even strong shocks and vibration

#### Laser Manufacture and Test

The superior wavelength and amplitude measurement capabilities of the 86120C multi-wavelength meter enable you to maximize the performance of your components in the factory. You can measure DFB, FP, and multiple DFB-laser wavelengths and amplitudes during burn-in, environmental evaluation, final test, and incoming inspection.

#### WDM Systems

With the 86120C, you can simultaneously resolve the individual optical carriers and accurately confirm wavelengths, powers, channel spacing, drift, and signal-to-noise ratios in WDM systems.

Combining measurement performance with a rugged and portable package, the multi-wavelength meter lets you easily and accurately verify the optical carrier performance of transmission systems during design and development in the lab as well as on the manufacturing floor.



86121A

### 86121A WDM Channel Analyzer



#### WDM System Installation, Verification & Maintenance Applications

The 86121A is a high performance Michelson interferometer-based channel analyzer for installation, commissioning, maintenance and monitoring of dense wavelength-division multiplexed (DWDM) systems. It is designed for easy, accurate and complete characterization of up to 200 simultaneous optical carriers. Extremely accurate measurements of channel wavelength, powers and optical signal-to-noise ratio are obtained easily with single button operation. The simplified user interface makes advanced measurements like channel spacing and drift easily.

The WDM channel analyzer allows you to verify the wavelengths of your system to within  $\pm 2$  ppm. The analyzer's outstanding performance, simplified user interface, unparalleled rugged design, light weight (9 kg), and portability, make it the ideal field instrument for DWDM system turn-up and commissioning, as well as for preventative and reactive maintenance applications. The analyzer is offered standard with an on-board disk drive and printer. This allows archiving and/or future analysis of measurement results, as well as documentation capability in remote settings.

Input/output interfaces such as RS-232 (serial) and GPIB, facilitate communications with the instrument and the WDM system under test. The availability of universal plug and play drivers enables remote connectivity with the instrument, allowing you to customize and centralize your measurements.

For more complete information, order the Lightwave Test and Measurement Catalog. See detailed description on page 600.

86037C  
8509B

- Flexible solution platforms
- High accuracy
- Fast throughput
- Custom capabilities

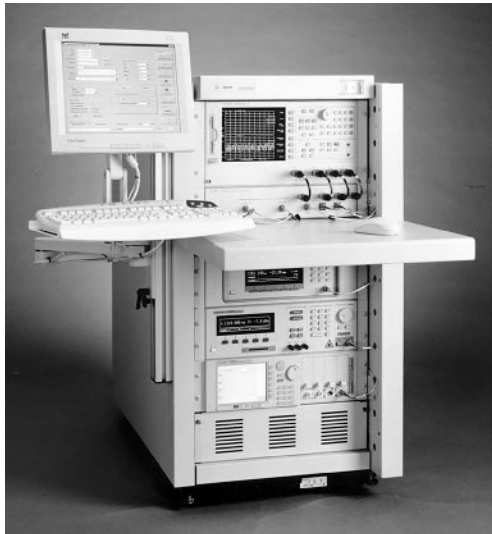

86037C Chromatic Dispersion Measurement System

### 86037C Chromatic Dispersion (CD) Test Solution

The 86037C CD test solution provides highly accurate and flexible dispersion measurements for high speed WDM components, fiber, gratings, and dispersion compensating devices. The racked configuration is ideal for manufacturing and R&D environments. The “C” version features a patented algorithm for improved accuracy in narrow-band devices and extended wavelength capability for measurement in the L-Band (up to 1640 nm) region, and a fast preview mode measurement.

The dispersion measurements are based on the modulation phase-shift/delay technique that has been adopted as the preferred method in system, sub-system and component level applications. An innovative “CD Side-Band” algorithm, patented by Agilent Technologies, is used to achieve greater group delay accuracy on narrow-band devices. The 86037C can be used to measure chromatic dispersion, group delay, length, and gain versus wavelength measurements. The “C” version now offers measurements at the 1600 nm wavelength range along with the 1300 and 1550 nm bands. Dual-band configurations are also available as standard options to measure dispersion at 1300 and 1550 nm or 1600 nm regions in a single rack.

In addition to the many standard options offered, custom solutions are available to meet your specific measurement requirements. For more complete information, contact your local Agilent field representative or regional Call Center to discuss how we might best address your needs.

For more complete information order the Lightwave Test and Measurement catalog. See detailed description on page 600.

- Automated polarization-mode dispersion (PMD) measurements using Jones Matrix Eigenanalysis and swept wavelength scanning technique
- Fast, automatic measurements of polarization-dependent loss (PDL) in optical components
- Calibrated, real-time measurements of state and degree of polarization (SOP and DOP)
- Built-in routine to align polarization maintaining fiber

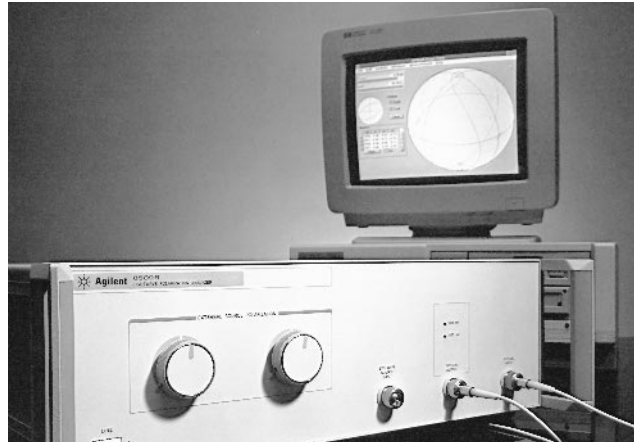

8509B

### 8509B Lightwave Polarization Analyzer

GPIB

The 8509B lightwave polarization analyzer system offers calibrated polarization measurements of optical signals and components. These capabilities are provided by innovations in hardware, software, and mathematics.

The 8509B contains built-in applications to make automated PMD and PDL measurements. PMD measurements can be made using Jones Matrix Eigenanalysis (JME) or the Wavelength Scanning (WS) technique with an Agilent tunable laser source. The JME method provides accurate PMD characterization of fiber and other components by providing differential group delay (DGD) measurements as a function of wavelength. The 8509B makes fast PDL measurements using the Power Max-Min (or polarization scanning) technique or Jones Matrix Eigenanalysis.

The 8509B system software provides easy-to-understand data display of the state of polarization (SOP) using the Poincaré sphere or polarization ellipse, relative Stokes parameter values, degree of polarization (DOP), average power, and polarization reference frames. A built-in polarization maintaining (PM) fiber launch routine offers a fast and intuitive way of aligning PM fiber to other optical components.

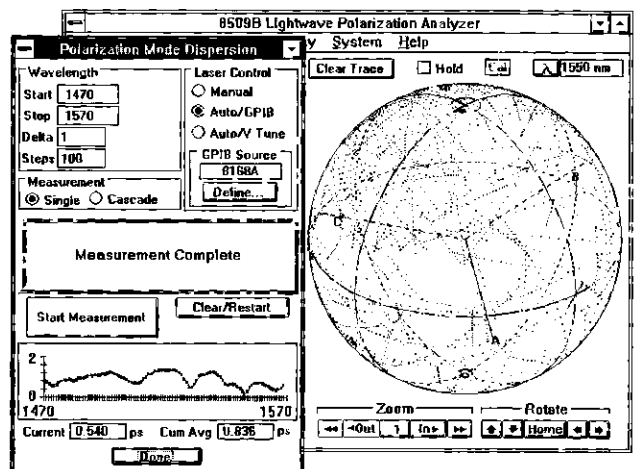

A polarization-mode dispersion graph is generated automatically as the system computer conducts the measurement.

- Bandwidth to 50 GHz
- 100 Mb/s to 12.5 Gb/s and beyond
- Built-in compliance tests
- Integrated optical and electrical channels
- Familiar Windows-98 user interface
- Compatible with 83480A series modules

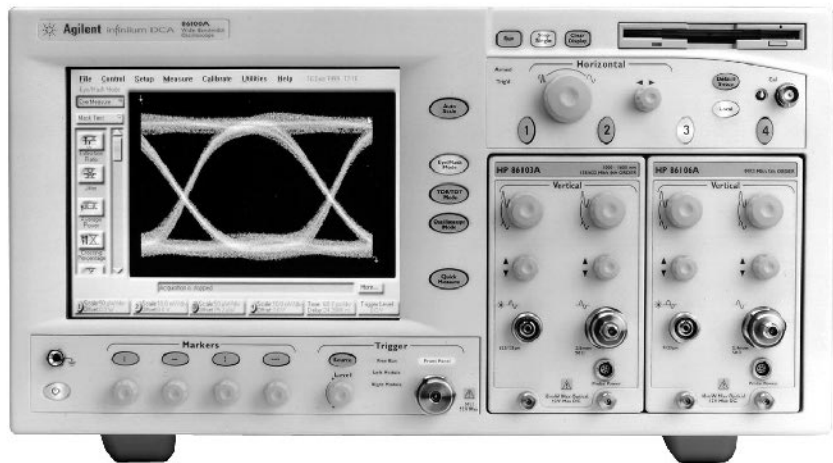

86100A

### 86100A Infiniium DCA – Wide-Bandwidth Oscilloscope



86100A Infiniium DCA was designed to make accurate waveform measurements fast and simple. The Infiniium DCA can be viewed as three instruments in one. It's a general purpose equivalent time sampling oscilloscope, a digital communication analyzer, and a time-domain reflectometer. Just select the instrument mode and start making measurements.

#### Familiar Windows-98 User Interface

The Infiniium DCA has an intuitive graphical user interface, so you won't have to spend a lot of time learning or relearning the instrument. Pull-down menus give you easy access to advanced features and icons provide quick access to an extensive set of common tests and measurements. Use the high-performance touchscreen or a mouse to navigate the instrument interface.

The simple, uncluttered front panel has the feel of an analog scope with dedicated scale and position knobs for each vertical channel. Trigger LEDs show you trigger status at a glance. To speed up measurements, you can configure the Quick Measure key for instant access to any four measurements in each instrument mode.

#### Measurement Speed

Measurement speed has been increased with both fast hardware and a friendlier user interface. In the lab, you can't afford to waste time figuring out how to make a measurement, the Infiniium DCA eliminates the relearning curve. In manufacturing, it is a battle to continually reduce cost per test. Infiniium DCA has fast PC-based processors, resulting in high measurement throughput and reduced test time.

#### Smaller Modular Platform

The Infiniium DCA has a large and growing family of plug-in modules designed for a broad range of data rates for optical and electrical waveforms. The Infiniium DCA can hold up to 2 modules for a total of 4 measurement channels. To protect your investment in Agilent's previous platform, all modules from the 83480A and 54750A family are forward compatible with the Infiniium DCA.

The Infiniium DCA is smaller and much lighter than the previous generation wide-bandwidth oscilloscopes. It also uses less than half the power the 83480A and 54750A used.

#### GPIB Code Compatible

The remote programming command set for the Infiniium DCA has been designed to be directly compatible with software written to control the 83480A and 54750A. (Due to improvements and updates in performance, a small set of remote commands may need minor modifications to control the Infiniium DCA).

#### Compliance Tests

Accurate eye-diagram analysis is essential for characterizing the quality of transmitters used from 100 Mb/s to beyond 12.5 Gb/s. The Agilent Infiniium DCA was designed specifically for the complex task of analyzing digital communications waveforms. Compliance mask and parametric testing no longer require a complicated sequence of setups and configurations. The important measurements you need are right at your fingertips, including:

- Industry standard mask testing with built-in margin analysis
- Extinction ratio measurements with improved accuracy and repeatability
- Automatic eye measurements: crossing %, eye height and width, '1' and '0' levels, jitter, rise or fall times and more.

#### Time Domain Reflectometer (TDR)

TDR measurements are focused on high-speed applications where it is necessary to optimize electrical system components, such as microstrip lines, PC board traces, SMA edge launchers, and coaxial cables where imperfections cause signal distortion and reflections. Signal integrity is a critical requirement in high-speed digital signal transmission.

#### Built-in Information System

Infiniium DCA's built-in information system puts measurement assistance at your fingertips. You'll no longer have to look for the manual when you need help setting up the DCA or making complex measurements. A set-up guide gives you step-by-step instructions for many measurements and procedures. Links on the measurement screen take you directly to the information you need in the on-line manual.

#### Internal Hard and Floppy Disk Drives

Use the internal 3 GB hard drive or the 3.5 inch, 120 MB SuperDisk floppy disk drive to store instrument setups, waveforms, or screen images. Screen images can be stored in many standard industry file formats. LAN access is supported for network access and file sharing.

#### Gated Triggering

Rear panel trigger gating port allows easy external control of data acquisition for circulating loop or burst-data experiments. Use TTL-compatible signals to control when the instrument does and does not acquire data.

#### Stimulus Response Testing Using the 86130A BitAlyzer

Error performance analysis represents an essential part of digital transmission testing. The Infiniium DCA and 86130A BitAlyzer error performance analyzer come together to create a powerful test solution where two instruments together can perform measurements that would not be possible. For more information on the 86130A BitAlyzer see page 406.



83430A  
83433A  
83434A  
83446A

- SDH/SONET compliant
- User adjustable extinction ratio
- 52, 155, 622 and 2488 Mb/s rates
- Clock and data recovery at 2.488 Mb/s
- High Sensitivity

- Excellent 10 Gb/s and 2.5 Gb/s optical waveforms
- Generates STM-64/OC-192 and STM-16/OC-48 compliant eye patterns
- Clock Recovery at 9953.28 MHz
- Linear, unretimed data output
- -16 dBm sensitivity (BER 1E-10 for 2<sup>31</sup>-1 PRBS)



83446A

### 83430A Lightwave Digital Source 83446A Lightwave Clock/Data Receiver

Agilent offers complete optical parametric test systems for test needs up to 2.5 Gb/s with the 83430A and 83446A. A complete system includes an error performance analyzer, which allows for measurements such as receiver sensitivity, dispersion power penalty of single-mode fiber, and laser transmitter optimization.

### 83430A Lightwave Digital Source

The 83430A is a modulatable DFB laser source that converts digital input signals to a preset optical output level that is SDH/SONET compliant. It is designed to evaluate the performance of high-speed TDM (time division multiplexed) and WDM (wavelength division multiplexed) optical receivers and systems to SDH/SONET OC-1 (51.84 Mb/s) through STM-16/OC-48 (2.488 Gb/s) standards.

The 83430A has three separate modulation inputs ports. The AC and DC coupled digital inputs convert ECL compatible input signals and the AC coupled analog input provides a general purpose input for direct modulation of the DFB laser. A wide range of optical signals can be simulated with the user adjustable extinction ratio (~8.2 to 13 dB) and the front-panel digital input threshold adjustment, which allows the user to obtain the desired symmetry of optical one and zero levels. The standard product has a 1550 nm center wavelength. An internal laser with center frequency of 1310 nm or any of the ITU grid wavelengths can be ordered as an option. A wavelength tunability feature gives you the ability to tune the wavelength to a specific value within ±1.25 nm of the center wavelength.

The 83430A can be combined with an error performance analyzer to test optical receiver sensitivity and dispersion power penalty. Multiple 83430As may be used to test WDM optical channel performance. And the 83430A can be combined with a sampling oscilloscope to provide transceiver waveform testing such as filtered conformance mask testing, extinction ratio and eye-diagram measurements.

### 83446A Lightwave Clock/Data Receiver

The 83446A is designed to extract clock and data information from digitally modulated lightwave signals at OC-48/STM-16 (2.488 Gb/s) data rate. The 83446A incorporates a high-gain avalanche photodiode (APD), gain controlled amplifier, and clock/data recovery hybrid to deliver clean, error-free outputs from optical signals with power as low as -27 dBm at either 1310 or 1550 nm wavelengths.

By connecting the 83446A clock and data outputs to the corresponding inputs on an error detector, bit-error-ratio analysis can be performed directly on optical signals, making it easy to do system acceptance and BER floor analysis. The 83446A can also be useful for optical eye diagram analysis with sampling oscilloscopes. In situations where no separate clock signal is available, the 83446A's clock output can be used to trigger the oscilloscope.

For analog monitoring of unconditioned data, the 83446A provides an auxiliary electrical output. This high-gain AGC controlled output is useful for general diagnostic analysis of the incoming waveform. (Because its frequency response does not meet the stringent requirements for eye mask compliance testing defined in SONET/SDH standards, mask test should be done with an appropriate reference receiver such as Agilent's 8344x series.) Another feature of the 83446A is a rear-panel input for recovering clock and data from an electrical waveform. The 83446A uses a 50 micron fiber core diameter which is compatible with either single-mode or multi-mode fibers.

For more complete information, order the Lightwave Test and Measurement Catalog. See detailed description on page 600.



83433A and 83434A

### 83433A 10 Gb/s Lightwave Transmitter 83434A 10 Gb/s Lightwave Receiver

NEW

The 83433A 10 Gb/s lightwave transmitter and the 83434A 10 Gb/s lightwave receiver provide the optical interfaces necessary to allow bit error rate testing of 10 Gb/s optical transmitters and receivers used in 10 Gb/s SDH/SONET and IP optical networks. The 83433A and 83434A may be combined to create a complete optical link for system or fiber testing.

### 83433A 10 Gb/s Lightwave Transmitter

The 83433A transmitter is based upon a lithium niobate modulator driven by an internal CW DFB 1552.52 nm laser. The laser and modulator are interconnected externally with a semi-rigid polarization-maintaining fiber (PMF). Alternatively, the modulator may be used with PMF and an external laser of wavelength between 1530 and 1565 nm, such as the 8164A with 81680A Option 071. The Mach-Zehnder modulator is adjusted for zero chirp.

The 83433A is designed to produce high-fidelity, low jitter waveforms from STM-16/OC-48 (2.488 Mb/s) to STM-64/OC-192 (9.953 Gb/s) and other transmission rates through 10.7 Gb/s. Its optical output meets the eye mask requirements of GR-253-CORE for OC-48 and GR-1377-CORE for OC-192. Its output waveform produces a minimum extinction ratio of 12 dB.

The internal DFB laser may be modulated at frequencies from 15 kHz to 10 MHz to increase linewidth for DWDM applications. The laser's wavelength can be manually adjusted +/-1 nm around the 1552.52 nm center wavelength or an internal laser with a different ITU grid center wavelength may be ordered as a special option.

### 83434A 10 Gb/s Lightwave Receiver

The 83434A receiver is designed to recover clock and provide linear, non-retimed data from digitally modulated SDH/SONET STM-64/OC-192 optical signals. The receiver is based on an amplified PIN diode to produce a linear output with AGC stabilization. The receiver is designed to provide -16 dBm sensitivity with PRBS lengths to 2<sup>31</sup>-1 with BER performance of at least 1E-10.

The recovered clock may be used as a trigger input for a sampling oscilloscope such as the Agilent Infiniium DCA to allow optical eye diagram measurements when no external clock signal is available for triggering. The recovered clock also provides the required clock input for the 71612B error performance analyzer's error detector. The non-retimed data output is designed to be used with the error detector's ability to optimize decision threshold and timing to optimize BER. The receiver's output is also appropriate for eye contour and Q-factor measurements.



- DC-coupled optical-to-electrical converter
- Bandwidths from dc to 30 GHz
- Fast-pulse response
- Optical receiver for BERT or oscilloscope



83440 Series

### 83440 Series Unamplified Lightwave Converters

The Agilent 83440 series offers a variety of bandwidth options for converting incoming modulated optical power or optical pulses into electrical current. Ideal for optical pulse parameter measurements, these fully-integrated hermetic InGaAs photodetectors feature very low noise and pulse aberrations, and fast, accurate O/E conversion. The converters mount directly on test-instrument front panels. Simple internal structure ensures low-signal distortion for improved output-signal fidelity, a novel optical launch ensures low optical reflection, and integral dc-bias regulation ensures stable frequency response performance.

The 83440 series can be used with high-speed digitizing oscilloscopes to accurately measure rise and fall time, overshoot, undershoot, ringing, peak power (pulse amplitude), pulse width, amplitude noise, and extinction ratio. The 83440 series also makes excellent mask measurements when sufficient optical power is available.

The 83440B Option 050 provides 50  $\Omega$  output required for use with external SDH Bessel-Thomson filters such as the 87441 family.

When using the 83440 with an ac-coupled instrument (except Option 050), a bias tee such as the 11612A or, alternatively, a 3 dB fixed attenuator on the output is required to provide a dc-bias return path.

### 11982A Amplified Wide Bandwidth Lightwave Converter

A wide-bandwidth, sensitive O/E converter for characterizing lightwave systems and components, the 11982A combines a PIN photodetector with a low-noise dc-coupled preamplifier to create a general-purpose front end. It covers wavelengths from 1200 to 1600 nm and bandwidths from dc to 15 GHz. With 300 V/W conversion gain and 0.05 percent input optical reflections, it significantly improves the sensitivity of the measurement system. The converter comes with a calibration chart of instrument-specific data for making corrected frequency-response measurements.

The 11982A can be combined with a digital communications analyzer to make optical eye-pattern and impulse-response measurements to verify optical and optoelectronic components and optical system level performance.

The 11982A can be used with an electrical spectrum analyzer to display optical modulation power as a function of frequency. Intensity modulation, distortion, and laser intensity noise are also measured. The Option 001 memory card programs an 8590 E series spectrum analyzer with frequency-response corrections, and menus for easy, accurate lightwave measurements to 22 GHz. Using this converter with the 11980A interferometer, you can measure linewidth (with a gateable modulation source), chirp, and frequency modulation of single-line lasers.

- Calibrated RIN measurements

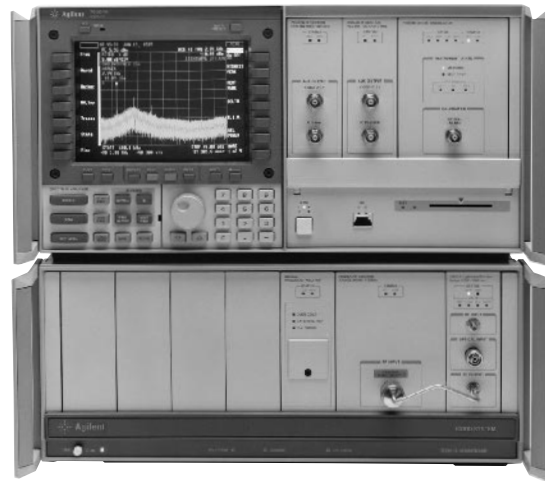

71400C

### 71400C and 71401C Lightwave Signal Analyzers



#### Calibrated Measurements of Intensity Modulation from 100 kHz to 22 GHz

The Agilent 71400C combines a high-performance microwave spectrum analyzer with a wideband, sensitive optical receiver. This system measures modulated light from 1200 to 1600 nm on single-mode optical fibers from 100 kHz to 22 GHz. Optical modulation, noise, and average power are presented on a fully-calibrated display.

With the 11980A fiber-optic interferometer, the analyzer can also measure linewidth. With an interferometer and a gated source, the analyzer can measure chirp and FM characteristics of distributed-feedback (DFB) and other single-line lasers. Or, for higher performance, replace the interferometer with a tunable laser.

This system is also a microwave spectrum analyzer with all the capability of the 71210C. Because the analyzer is modular, its measurement capabilities can be expanded easily.

The 71400C measures intensity modulation up to 22 GHz and operates over wavelengths from 1200 to 1600 nm. It can achieve an optical sensitivity of better than -60 dBm. The analyzer also offers average-power measurement, displayed both as a real-time vertical power bar and as a digital readout. Full calibration of both average power and modulation power makes this system a reference receiver for measuring and characterizing optical detectors and receivers.

A program for enhanced relative intensity noise (RIN) measurement is included. This program subtracts thermal noise and shot noise components of the measurement and calculates RIN to -165 dB/Hz.

The 71401C has an upper frequency limit of 2.9 GHz but the same functions and features as the 71400C. Both models provide lightwave optical or electrical units in either log (dB) or linear (watts) units, as well as microwave units for electrical spectrum analysis.

### 70810B Lightwave Receiver Module

The 70810B lightwave section is a receiver module with a built-in average power meter and attenuator, a wavelength range of 1200 to 1600 nm, a detected modulation bandwidth of 100 kHz to 22 GHz, and a built-in, 32 dB RF amplifier that gives an optical sensitivity of -60 dBm in a 10 Hz bandwidth. It can be used in standalone applications as a lightwave receiver or housed in an 70000 series electrical spectrum analyzer.

For more complete information, order the Lightwave Test and Measurement Catalog. See detailed description on page 600.

11982A  
83440B  
83440  
Series  
70810B  
71400C  
71401C

8702D  
8703A  
86030A

- 300 kHz to 20 GHz modulation frequency
- 850, 1300 or 1550 nm operation
- Calibrated frequency response measurements of high-speed optical, electro-optical, and electrical components
- Modulation response, distortion and depth measurements

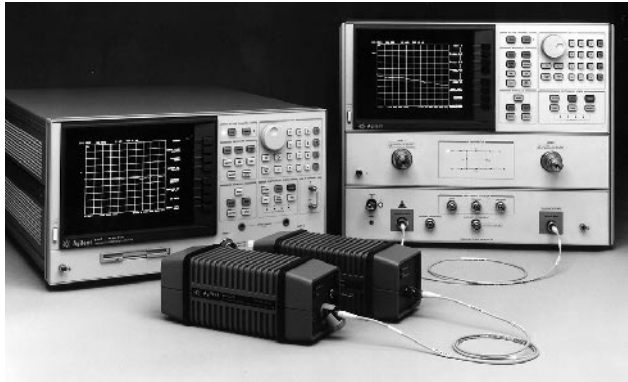

8702D and 8703A

### Lightwave Component Analyzers

The Agilent 8702D and 8703A precisely characterize the swept modulation frequency response of wide bandwidth fiber optic system elements such as WDM components, lasers, LEDs, photodiodes, and electro-optical modulators. Both the 8702D and 8703A operate at a fixed wavelength and sweep the frequency of the intensity modulation signal over the bandwidth you select.

The 8702D has 1300 and 1550 nm lightwave sources and receivers as well as an 850 nm receiver. The 8703A can operate at 1300 or 1550 nm. These sources and receivers are characterized to allow calibrated measurements of electro-optical test devices.

When used to measure linear electrical components, such as filters, amplifiers, and transmission lines, the lightwave component analyzers provide the full measurement capability of a microwave network analyzer. Typical measurements are bandwidth, insertion loss/gain, phase, impedance, match, and group delay.

### 8702D Lightwave Component Analyzer



300 kHz–3 GHz (850 nm) 300 kHz–6 GHz (1300, 1550 nm)

The 8702D offers several significant improvements in versatility, performance and productivity.

- high optical calibration accuracy
- built-in 3.5-inch floppy disk drive with LIF/DOS formats
- integrated S-parameter test set
- serial and parallel printer interfaces
- test sequencing for automated measurements
- multiple source and receiver choices

### 8703A Lightwave Component Analyzer



130 MHz–20 GHz (1300 or 1550 nm)

The standard configuration includes one 1300/1550 nm receiver and one lightwave directional coupler. A 1300 or 1550 nm DFB internal laser source must be specified. The external lightwave source input (Option 100) can be used for additional wavelength flexibility. Lasers with a center wavelength between 1530 and 1570 nm require 8703A Options 100 and 210 (1550 nm). Lasers with center wavelength between 1290 and 1330 require 8703A Options 100 and 220 (1300 nm).

- Frequency response measurements of very high-speed fiber optic components
- Calibrated amplitude and phase measurements
- Guided measurement software
- Performance verification procedure with verification device
- 45 MHz to 50 GHz modulation range
- LAN connectivity
- 1550 nm optical carrier



86030A

### 86030A Lightwave Component Analyzer



#### 50 GHz Lightwave Component Analyzer

The Agilent 86030A lightwave component analyzer measures optical and microwave components of high-speed fiber optic transmission systems. The analyzer characterizes the bandwidth or reflection of O/E (optical-electrical), E/O, E/E, and O/O devices in magnitude and/or phase.

The integrated system accurately characterizes:

- Photodiodes
- Lasers
- Optical assemblies
- Transmitter/receiver pairs
- Electrical microwave circuits

#### Guided measurement software

Guided measurement software is part of the system, and provides an easy-to-use operator interface. It provides pictorial diagrams of interconnections for configuration, calibration, and measurements, and on-screen prompts to guide you through the entire measurement process, from the calibration to the measurement.

#### Calibrated measurements

The 86030A is factory calibrated using a YAG laser heterodyne technique for amplitude calibration, and a specially developed optical impulse technique for characterizing and calibrating phase measurements. This gives you the ability to make calibrated measurements of your devices quickly and easily, and provides confidence in your device's performance.

#### System verification

A system verification device is included with the lightwave component analyzer. You can use the verification device and its associated amplitude and phase characteristics to verify the measurement integrity of the 86030A system. The guided verification procedure leads you through the verification device measurement and compares the measured data to the factory standard data to insure system accuracy.

#### Ordering Information

**86030A** 50 GHz Lightwave Component Analyzer

Standard system is provided with FC/PC optical connectors.

- Opt 011 Diamond HMS-10 optical connector interface
- Opt 013 DIN 47256 optical connector interface
- Opt 014 ST optical connector interface
- Opt 017 SC optical connector interface
- Opt 230 220-240 VAC operation

**Overview**

Lightwave Test & Measurement Catalog  
[5980-8000E/EUS](#)

**Optical Component Test**

Lightwave Test & Measurement Catalog  
[5980-8000E/EUS](#)

EDFA Testing—Problems and Solutions  
[5963-2273E](#)

E5574A Optical Loss Analyzer Sources  
Configuration Guide  
[5963-6886E](#)

Brochure

[5963-6889E](#)

Technical Specifications

[5964-1524E](#)

PDL Measurements Using the 8169A  
Polarization Controller.

[5964-9937E](#)

8153A Modular System for Optical Power Loss  
and Return-Loss Measurements Brochure  
[5963-7132E](#)

8156A Optical Attenuator Brochure  
[5091-7758E](#)

8156A Optical Attenuator Configuration Guide  
[5963-3367E](#)

8156A Optical Attenuator Technical Data Sheet  
[5962-8631E](#)

(PN 8167B) Tunable Laser Source 8167B,  
8168D, 8168E, 8168F

[5964-9542E](#)

(PN 8168E/F) 8168E and 8168F Tunable  
Laser Sources

[5965-5877E](#)

(PN 11896-2) Polarization-dependent  
Loss Measurements Using Modular  
Test System Configurations

[5965-5720E](#)

(PN 81534A) Measuring the Return Loss  
of Fiber Optic Components—81534A Return  
Loss Module

[5091-2639E](#)

**Lightwave Test System Solutions**

Lightwave Test & Measurement Catalog  
[5980-8000E/EUS](#)

86060C Series of Lightwave Switches Product  
Overview

[5967-5902E](#)

86037C Chromatic Dispersion Test System,  
Product Overview

[5980-0815E](#)

**Precision Reflectometers &  
Polarization Analyzers**

Lightwave Test & Measurement Catalog  
[5980-8000E/EUS](#)

8509B Lightwave Polarization Analyzer Product  
Overview

[5966-1557E](#)

(PN 8509-1) Polarization Measurements of  
Signals and Components

[5091-2879E](#)

(PN 8509-2) Narrow-band PMD Measurements  
with the 8509B

[5968-5587E](#)

(cont'd.)

## Spectrum, Component & Signal Analyzers

Lightwave Test & Measurement Catalog  
[5980-8000E/EUS](#)

11982A Amplified Lightwave Converter  
 Product Overview  
[5966-1583E](#)

70880A Line Width Measurement Personality  
 Product Overview  
[5091-5541E](#)

71400C, 71401C Signal Analyzers  
 Product Overview  
[5980-1929E](#)

83737A Broadband Light Source, 83738A  
 Erbium ASE Source Product Overview  
[5965-3252E](#)

86030A 50 GHz Lightwave Component Analyzer  
 Product Overview  
[5968-9734E](#)

8702D LW Component Analyzer Brochure  
[5965-5624E](#)

8702D LW Component Analyzer  
 Configuration Guide  
[5965-6403E](#)

8702D LW Component Analyzer System  
 Technical Specifications  
[5965-6404E](#)

8703A LW Component Analyzer  
 Technical Specifications  
[5952-1754E](#)

8614XB Optical Spectrum Analyzer Family  
 Technical Specifications  
[5968-0177E](#)

8614XB OSA Family for Factory & Field  
 Applications Brochure  
[5968-9663E](#)

(PN 86140-2) External Multi-Point Wavelength  
 Calibration for the 8614XB Series of Optical  
 Spectrum Analyzers  
[5980-0043E](#)

(PN 71400-1) Lightwave Signal Analyzers  
 Measure Relative Intensity Noise  
[5091-2196E](#)

(PN 71400C-2) Lightwave Signal Analyzers  
 with the 70810B LW Section  
[5091-2324E](#)

(PN 86120-1) WDM System Test with the 86120  
[5964-6896E](#)

(PN 71452-1) 71452 Optical Spectrum  
 Analyzer—EDFA Testing with the  
 Interpolation Technique  
[5963-7146E](#)

(PN 71452-2) 71452B Optical Spectrum  
 Analyzer—EDFA Testing with the Time  
 Domain Technique  
[5963-7147E](#)

(PN 71452-4) 71452B Optical Spectrum  
 Analyzer—Synchronizes Its Internal  
 Activities With External Signals  
[5964-6416E](#)

(PN 71452-3) 71452B OSA-EDFA Noise  
 Gain Profile  
[5963-7148E](#)

(AN 1550-5) Accurate Characterization of  
 Source Spectra  
[5980-0746E](#)

## Digital Communications Analyzers

Lightwave Test & Measurement Catalog  
[5980-8000E/EUS](#)

11982A Amplified LW Converter Product  
 Overview  
[5966-1583E](#)

83433A 10 Gb/s Lightwave Transmitter,  
 83434A 10 Gb/s Lightwave Receiver  
 Product Overview  
[5968-9251E](#)

83446A Clock/Data Receiver Product Overview  
[5964-1682E](#)

83440B/C/D High-Speed Lightwave Converters  
 Product Overview  
[5091-5536E](#)

83491A/92/93A Clock Recovery Modules  
[5968-4154](#)

Infiniium DCA 86100A Wide-Bandwidth  
 Oscilloscope Technical Specifications  
[5968-8546E](#)

Infiniium DCA/In the Complex World of  
 High-Speed Data Transmission Accurate  
 Waveform Measurements Are Fast and  
 Simple (Brochure)  
[5968-8548E](#)

10 Methods for Faster High-Speed Digital  
 Communications Design Brochure  
[5966-4258E](#)

(AN 1550-8) Measuring Extinction Ratio  
 of Optical Transmitters  
[5968-4316E](#)

## Optical Wavelength Meter

86120C Multi-Wavelength Meter Brochure  
[5968-1044E](#)

86120C Multi-Wavelength Meter  
 Technical Specifications  
[5968-1045E](#)

86121A WDM Channel Analyzer Brochure  
[5968-6422](#)

86121A WDM Channel Analyzer  
[5968-5393E](#)

(PN 86120-1) WDM System Test  
[5964-6896](#)



**Overview** 482

**Impedance Measuring Instruments** 485

*See also*  
Network Analyzers 271  
Network/Spectrum Analyzers 266

**Materials Test Equipment** 491

*See also*  
Network Analyzers 271

**LCR & Resistance Meters** 494

**Additional Literature** 501

## E

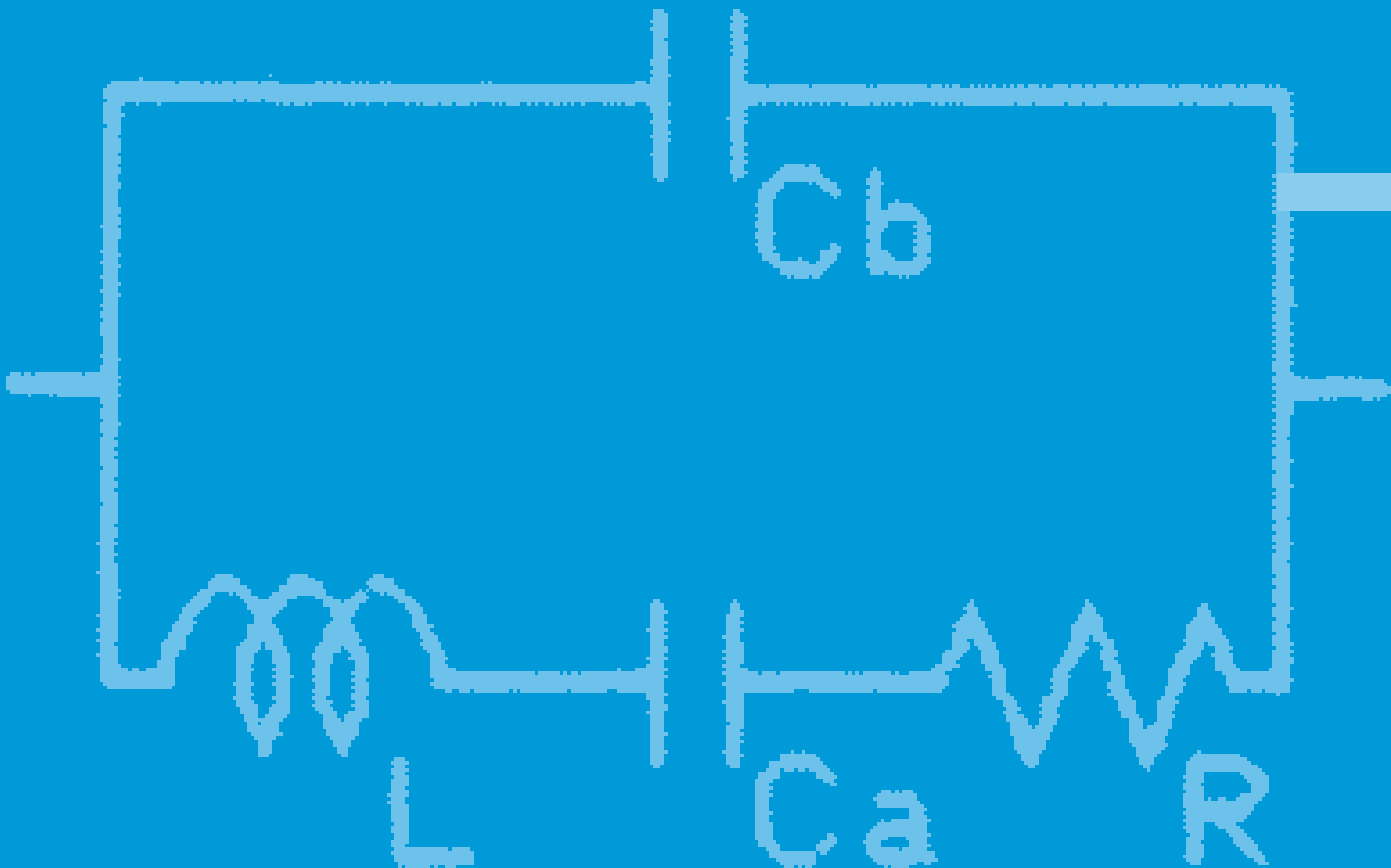

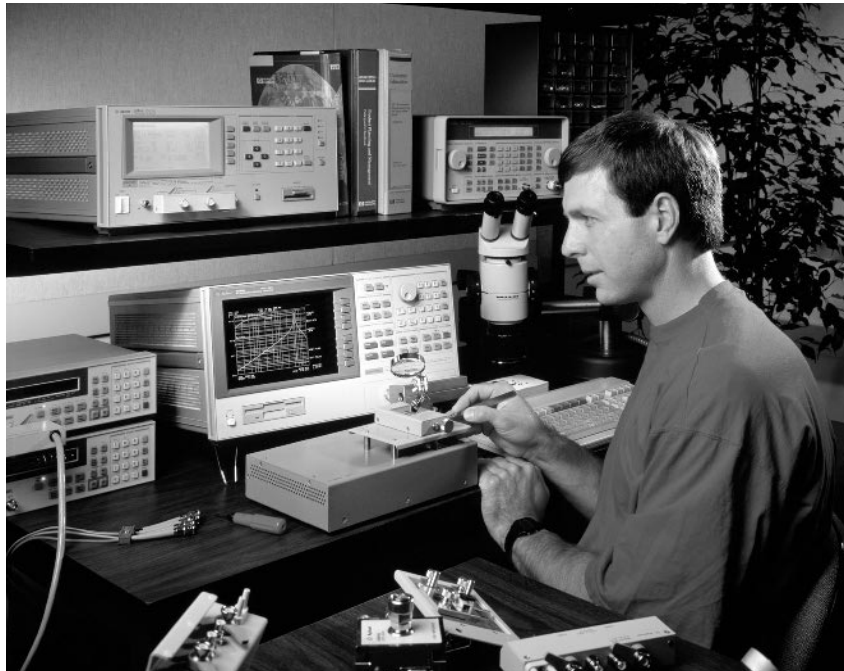

## Component Measurement

Today's electronic components are designed for higher performance, while being reduced in size, power consumption, and cost. Efficient and accurate component characterization, design evaluation, and manufacturing test are critical to the success of component users and suppliers. Agilent Technologies offers the industry's broadest line of component test instruments for passive as well as active components. The products in this section are designed to measure fundamental impedance-related parameters of electronic components and materials.

## 12 Impedance Measuring Instruments

Impedance measuring instruments can be divided into two general categories: LCR meters and impedance analyzers. LCR meters pri-

marily measure inductance, capacitance, and resistance of the test device at spot frequencies. Impedance analyzers, in addition to all the functions of the LCR meter, measure impedance, phase, and sometimes transmission parameters. These analyzers have extended frequency range, a synthesized source, swept frequency capability, and excellent frequency resolution. Combination network/spectrum/impedance analyzers offer the benefits of impedance analysis as well as vector-network and spectrum analysis. See the Selection Guides that follow for general instrument capabilities. For higher frequencies (above 3 GHz) in a 50Ω environment, a dedicated vector-network analyzer is the best solution for impedance measurements. See Network Analyzers.

Selecting a test fixture is as important as selecting the right instrument. Agilent as offers a wide range of accessories for axial, radial, and SMD chip devices. See page 484.

## Materials Measurements

Materials have two properties that determine how they interact with electromagnetic fields:

- Permittivity ( $\epsilon$ ) or dielectric constant for electric fields
- Permeability ( $\mu$ ) for magnetic fields

Permittivity ( $\epsilon^* = \epsilon' - j\epsilon''$ ) and permeability ( $\mu^* = \mu' - j\mu''$ ) are complex values. The real part ( $\epsilon'$  or  $\mu'$ ) is a measure of how much energy is stored in a material. The imaginary part ( $\epsilon''$  or  $\mu''$ ) is a measure of how much energy is lost in a material. These properties are not constant and may change with frequency or temperature, for example. Accurate measurements of these material properties during characterization or inspection help to achieve the best performance for a given application while shortening design cycles and minimizing scrap.

A materials measurement system consists of an instrument, a fixture to hold the material, and software or firmware to calculate complex permittivity or permeability values and display the results. For material testing applications, Agilent currently offers three types of solutions: LCR meter-based (up to 1 GHz), impedance analyzer-based (up to 1 GHz), and network analyzer-based systems (up to 110 GHz).

Agilent offers fixture accessories based on the open-ended coaxial probe, the transmission line measurement, the parallel plate capacitance, and the inductor impedance technique. These choices allow you to best match the fixture, frequency range, and measurement technique with your material's physical and electrical test requirements. The chart of material test applications and solutions is shown in the next page.

## Other Component Test

Agilent provides other high performance test solutions for specific applications such as hard disk read/write testing, VCO/PLL signal measurements and resonator and filter measurements. See pages 526 and 527 for hard disk read/write testing, pages 342, 343 and 344 for VCO/PLL signal measurements, pages 281 and 282 for resonator and filter measurements.

## Impedance Analyzer Selection Guide

Model	Frequency Range	Impedance Range/Other	Additional Information	Page
4192A	5 Hz to 13 MHz	1 Ω to 1 MΩ*, gain-phase	Floating or grounded devices	496
4291B	1 MHz to 1.8 GHz	0.1 Ω to 50 kΩ*	Color display, IBASIC, SMD fixtures, equivalent circuit analysis, material	485, 486
4294A	40 Hz to 110 MHz	25 m Ω to 40 MΩ*	Color display, equivalent circuit analysis, IBASIC, LAN I/F, SMD fixtures	489, 490
4395A**	100 kHz to 500 MHz	2 Ω to 5 kΩ* S-parameters, gain-phase	Color display, vector-network and spectrum analysis, IBASIC	266, 267
4396B**	100 kHz to 1.8 GHz	2 Ω to 5 kΩ* S-parameters, gain-phase	Color display, vector-network and spectrum analysis, IBASIC	268, 269
E4991A	1 MHz to 3 GHz	0.1 Ω to 50 kΩ*	Color display, VBA, SMD fixtures, equivalent circuit analysis, material, LAN I/F	487, 488

\* 10% accuracy range  
\*\* with Opt 010 and 43961A

## LCR and Resistance Meter Selection Guide

Model	Frequency Range	Impedance Range/ Other	Additional Information	Page
4263B	100 Hz to 100 kHz (5 test frequencies)	1 mΩ to 100 MΩ	Optional transformer test	494
4268A	120 Hz/1 kHz	0.0001 nF to 2000 μF	High-value ceramic capacitor test	498
4284A	20 Hz to 1 MHz (8610 freq. points)	0.01 mΩ to 100 MΩ	42841A for high-current dc bias	495, 496
4285A	75 kHz to 30 MHz (100 Hz steps)	0.01 mΩ to 100 MΩ		495, 496
4287A	1 MHz to 3 GHz (100 kHz steps)	200 mΩ to 3 kΩ	Higher-accuracy, higher-speed RF LCR meter	497
4278A	1 kHz/1 MHz	0.00001 pF to 200 μF	High-speed capacitor test	498
4279A	1 MHz	0.00001 pF to 1280 pF	C-V meter, 0 to ± 38 V	498
4288A	1 kHz/1 MHz	0.00001 pF to 20 μF	High-speed capacitor test	498
4339B	dc	1 kΩ to 1.6 × 10 <sup>16</sup> Ω	High-resistance meter, volume and surface resistivity, current	500
4338B	1 kHz test signal	10 μΩ to 100 kΩ	Milliohm meter	499

## Material Test Applications and Solutions

	DC resistivity cell (16008B) Page 500	Dielectric test fixture (16451B) Page 493	Liquid dielectric test fixture (16452A) Page 493	Dielectric and magnetic test fixtures (16453A) (16454A) Page 492	Dielectric probe system (85070M) Page 491	Agilent material measurement software (85071B) Page 491
Absorber					•	•
Ceramic	•	•		•	•	
Fermentation					•	
Film (thin)		•		•		
Food					•	
Gel, semi-solid					•	
Liquid			•		•	
Loss		•	•	•	•	
Permeability				•		•
Permittivity (dielectrics)		•	•	•	•	•
Plastic	•	•		•	•	
Powder					•	
Printed circuit board		•		•		
Resistivity	•					
Rubber	•	•		•	•	
Solid	•	•		•	•	
Substrate	•	•		•	•	

## Other Component Test Solutions

Model	Frequency Range	Brief Description	Page
<b>Resonator/ Filter Test</b> E5100A	10 kHz to 180/300 MHz	Network analyzer best fitted for production line especially for resonator and filter manufacturer with fast measurement speed, low noise floor and powerful dedicated commands.	281–282
E5100B	10 kHz to 300 MHz	Economy model with limited functions	281–282

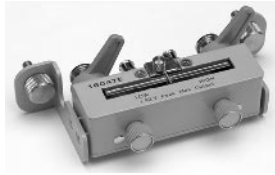

16047E



16034G



16044A



16089E



16196A/B/C

	4192A	4263B	4268A	4278A	4279A	4284A	4285A	4287A	4288A	4291B	4294A	4294A with 42942A	4395A with Opt.010 and 43961A	4396B with Opt.010 and 43961A	E4991A
16034E															
16034G															
16034H															
16043A/B															
16044A															
16047A															
16047C															
16047D															
16047E															
16048A															
16048B															
16048D															
16048E															
16048G															
16048H															
16060A															
16065A															
16065C															
16085B															
16089A/B/C/D/E															
16092A															
16093A															
16093B															
16094A															
16095A															
16191A															
16192A															
16193A															
16194A															
16196A/B/C															
16197A															
16200B															
16314A															
16315A															
16316A															
16317A															
16334A															
16451B															
16452A															
16453A															
16454A															
42842A/B															
42842C															
42941A															
42942A															

## Test Accessories/Fixtures

16034E	SMD/Chip Test Fixtures	DC-40MHz
16034G	SMD/Chip Test Fixture, Small	DC-110MHz
16034H	SMD/Chip Test Fixture, General	DC-110MHz
16043A/B	3-Terminal SMD Test Fixture	DC-110MHz
16044A	SMD/Chip Test Fixture, Four-Terminal, 10MHz	DC-10MHz
16047A	Axial and Radial Test Fixture	DC-13MHz
16047C	Axial and Radial Test Fixture	DC-40MHz
16047D	Axial and Radial Test Fixture	DC-40MHz
16047E	Axial and Radial Test Fixture, 110MHz	DC-110MHz
16048A	One Meter Test Leads, BNC	DC-30MHz
16048B	One Meter Test Leads, SMC	DC-30MHz
16048D	Two Meter Test Leads, BNC	DC-30MHz
16048E	Four Meter Test Leads, BNC	DC-1MHz
16048G	One Meter Test Leads, BNC, 110MHz	DC-110MHz
16048H	Two Meter Test Leads, BNC, 110MHz	DC-110MHz
16060A	Transformer Test Fixture	DC-100KHz
16065A	Ext. Voltage Bias with Safety Cover (<=200 vdc)	50Hz-2MHz
16065C	External Bias Adapter (<=40 vdc)	50Hz-1Mz
16085B	4-Terminal Pair to 7 mm Adapter	DC-40MHz
16089A/B/C/D/E	Kelvin Clip Leads	5Hz-100KHz
16092A	RF Spring Clip: Axial, Radial and SMD	DC-500MHz
16093A	RF Two Terminal Binding Post	DC-250MHz
16093B	RF Three Terminal Binding Post	DC-250MHz
16094A	RF Probe Tip/Adapter	DC-125MHz
16095A	LF Impedance Probe	DC-13MHz
16191A	Side (Bottom) Electrode SMD Test Fixture	DC-2GHz
16192A	Parallel Electrode SMD Test Fixture	DC-2GHz
16193A	Small Side (Bottom) Electrode SMD Test Fixture	DC-2GHz
16194A	High Temperature Component Text Fixture	DC-2GHz
16196A/B/C	Parallel Electrode SMD Test Fixture	DC-3GHz
16197A	Bottom Electrode SMD Test Fixture	DC-3GHz
16200B	External DC Bias Adapter	1MHz-1GHz
16314A	4-Terminal Balun (50 Ω Bal. to 50 Ω Unbal.)	100Hz-10MHz
16315A	1-Terminal Balun (50 Ω Bal. to 50 Ω Unbal.)	100Hz-10MHz
16316A	1-Terminal Balun (50 Ω Bal. to 100 Ω Unbal.)	100Hz-10MHz
16317A	1-Terminal Balun (50 Ω Bal. to 600 Ω Unbal.)	100Hz-3MHz
16334A	SMD/Chip Tweezers	DC-15MHz
16451B	Dielectric Material Test Fixture	5Hz-30MHz
16452A	Liquid Test Fixture	20Hz-30MHz
16453A	Dielectric Material Test Fixture	1MHz-1GHz
16454A	Magnetic Material Test Fixture	1kHz-1GHz
42842A/B	High Bias Current 20A/40A Test Fixture	20Hz-1MHz
42842C	High Bias Current 10A Test Fixture	75kHz-30MHz
42941A	Impedance Probe Kit	DC-110MHz
42942A	4-Terminal Pair to 7mm Adapter	DC-110MHz

Note : Refer to the accessory descriptions for frequency and operational limits.

<sup>1</sup> Compatible when used in conjunction with 16085B.

<sup>3</sup> Do not connect the ground lead to the instrument

<sup>2</sup> 7mm cable is required

<sup>4</sup> 3.5mm(m) to 7mm Adapter is required



- Basic accuracy  $\pm 0.8\%$
- Advanced calibration and error compensation
- Four component test fixtures (DUT size: 0.5 mm to 20 mm)
- Independent parameter selection in 2 channels

- Direct read-out permittivity, permeability (option)
- Two material fixtures (operating temperature:  $-55^{\circ}\text{C}$  to  $+200^{\circ}\text{C}$ )
- Versatile analysis (temperature, cole-cole plot, relaxation time)
- Sweep parameters (frequency, ac level, dc bias, temperature)



4291B

### 4291B RF Impedance/Material Analyzer



#### Excellent Performance

The 4291B RF impedance/material analyzer provides a total solution for high-accuracy and easy measurement of surface-mount components and dielectric/magnetic materials. The 4291B uses a direct current-voltage measurement technique, opposing the reflection measurement technique, for more accurate impedance measurement over wide impedance range. Basic impedance accuracy is  $\pm 0.8\%$ . High Q accuracy enables low-loss component analysis. An internal synthesizer sweeps frequency from 1 MHz to 1.8 GHz with 1 mHz resolution. A 1.8-m error-less cable connects the analyzer to a test station so you can extend your test point away from the analyzer without losing accuracy. Advanced calibration and error compensation function eliminate measurement error factors in fixtures and assure high accuracy and repeatability at DUT/MUT.

The 4291B also provides automatic level control and monitor of test signals by using IBASIC programming function; devices can be measured under a constant voltage or current. Measure bias-dependent impedance characteristics with optional dc bias (up to 40 V and 100 mA). At the push of a button, the built-in Equivalent Circuit Analysis Function automatically calculates the circuit constant values of five circuit models.

The 4291B has two measurement channels; each channel can be set to measure a single (e.g. Z) or dual (e.g. Z- $\theta$ ) impedance parameter. The color TFT with split-display can show both active traces and memory traces (stored in RAM). A built-in floppy disk drive stores programs and test data in either LIF or MS-DOS format.

With built-in IBASIC, you can control external test equipment such as a temperature chamber or wafer prober directly from the 4291B. You do not need a separate instrument controller.

#### Material Evaluation

The 4291B enables easy and sophisticated material evaluation and improves material evaluation quality and efficiency. The 4291B provides the total dielectric/magnetic material measurement solutions in wide frequency range (1 MHz to 1 GHz). See page 492 for more information.

#### Key Features

- Direct material parameter read-out (permittivity, permeability)
- Material analysis functions (Cole-Cole plots, relaxation time analysis)
- Versatile evaluation using a variety of swept parameters (frequency, signal level, temperature, etc.)

#### Test Fixtures

Select from various types of component test fixtures (see page 488 for more information). These test fixtures directly connect to the test station's 7mm connector. Each fixture is designed for a different component size range, from 0.5 mm to 20 mm, and can handle different types of termination. These adjustable fixtures simplify device connection. For temperature coefficient testing, the 16194A high-temperature component test fixture can be used in a temperature oven from  $-55^{\circ}\text{C}$  to  $+200^{\circ}\text{C}$ . Together with the 4291B's built-in compensation software, the fixtures ensure impedance accuracy and measurement repeatability. The 16453A dielectric material test fixture and 16454A magnetic material test fixture improve the accuracy and ease of use for permittivity or permeability measurements. These material fixtures have wide operating temperature of  $-55^{\circ}\text{C}$  to  $+200^{\circ}\text{C}$ .

For measuring thin-film devices and semiconductors, the 4291B easily interfaces to a wafer prober. An extension cable connects the 4291B's test head to a probe station. For temperature and humidity testing, the 4291B can control an external temperature humidity chamber via GPIB and display the measurement result vs. temperature or humidity.

#### Ease of Use

With the 4291B, impedance testing is easy. The analyzer comes with on-line calibration and compensation routine to simplify the task. Markers and limit-line function offer quick data analysis.

## Specifications

### Measurement Parameters

**Impedance Parameters:**  $|Z|$ ,  $|Y|$ ,  $\Theta$ , R, X, G, B, Cp, Cs, Lp, Ls, Rp, Rs, D, Q  
**Converted Parameters:**  $|\Gamma|$ , U, Ix, Iy  
**Material Parameters:**  $|\epsilon|$ ,  $\epsilon'$ ,  $\epsilon''$ ,  $|\mu|$ ,  $\mu'$ ,  $\mu''$   
**Operating Frequency:** 1 MHz to 1.8 GHz  
**Frequency Resolution:** 1 mHz  
**Frequency Reference Accuracy:**  $< \pm 10$  ppm/@ 23° C  $\pm 5^\circ$  C  
**Precision Frequency Reference (Option 1D5)**  
**Accuracy:**  $< \pm 1$  ppm/year @ 0° C to 55° C, referenced to 23° C

### Basic Measurement Accuracy

Frequency (Hz)	Impedance %	Phase (radian)
1 M to 100 M	0.8	8 m
200 M	1.0	10 m
500 M	1.5	15 m
1 G	2.5	25 m
1.8 G	4.0	40 m

### Source Characteristics

**OSC Level:**  
 0.2 mV to 1 V rms (1 MHz to 1 GHz)  
 (Output terminal open)  
 0.2 mV to 0.5 V rms (1 GHz to 1.8 GHz)  
**Basic OSC Level Accuracy:** 2 dB + 6 dB X f[MHz]/1800 @ 23° C  $\pm 5^\circ$  C;  
 (terminated with 50  $\Omega$ ) @  $V \geq 250$  mV  
**Display Level Unit:** V, I, dBm  
**Level Monitor Function:** Voltage, Current  
**Connector:** 7mm  
**Output Impedance (nominal value):** 50  $\Omega$

### DC Bias

**DC Level:** 0V to  $\pm 40$  V, 0A to  $\pm 100$  mA  
**DC Level Accuracy:**  
**Voltage Level:** 0.1% + 4 mV + (I<sub>dc</sub>[mA] X 5 [ $\Omega$ ] mV @ 23° C  $\pm 5^\circ$  C  
**Current Level:** 0.5% + 30  $\mu$  A + (V<sub>dc</sub>[V]/10 [k $\Omega$ ]) mA @ 23° C  $\pm 5^\circ$  C  
**DC Level Monitor Function:** Voltage, Current

### Sweep Characteristics

**Sweep Parameter:** Frequency, AC signal level,  
 DC bias voltage/current (temperature by using IBASIC)

### Capacitor Calibration/Composition

Open/Short/50  $\Omega$  Calibration, Low-loss capacitor  
 Open/Short/Load Compensation, Port extension, Fixture electrical length

### Display

**CRT**  
**Type:** Color TFT  
**Size:** 8 inch  
**Number of Display Channels:** 2  
**Format:** Single, dual, active + memory, graphic, and tabular

### Key Specifications of Test Fixtures

Type of fixture	16191A	16192A	16193A	16194A	16196A	16196B	16196C	16197A
<b>Operating freq. (typ.)</b>	DC to 2 GHz	DC to 2 GHz	DC to 2 GHz	DC to 2 GHz	DC to 3 GHz	DC to 3 GHz	DC to 3 GHz	DC to 3 GHz
<b>Operating temperature</b>	-55° C to +85° C	-55° C to +85° C	-55° C to +85° C	-55° C to +200° C	-55° C to +85° C	-55° C to +85° C	-55° C to +85° C	-55° C to +85° C
<b>DUT size (length: mm)</b>	2.0 to 12.0	1.0 to 20.0	0.5 to 3.2	2.0 to 15.0	1.6 x 0.8 only (L x W:mm)	1.0 x 0.5 only (L x W:mm)	0.6 x 0.3 only (L x W:mm)	1.0 to 3.2

## Storage

**Type:** Built-in 3 $\frac{1}{2}$ -inch floppy disk drive; volatile RAM disk memory  
**Disk Format:** LIF, DOS  
**Programming:** Instrument BASIC (built-in)  
**Input and Output Characteristics**  
**External Reference Input:** 10 MHz  $\pm$  100 Hz typical  
**Internal Reference Output:** 10 MHz nominal  
**Reference Oven Output (Option 1D5):** 10 MHz nominal  
**External Trigger Input:** BNC female, TTL Level

## General Specifications

**Operating Temperature/Humidity:** 10° C to 50° C/15% to 80% RH  
**Warm-Up Time:** 30 min.  
**Power Requirements:** 90 V to 132 V, or 198 V to 264 V, 47 Hz to 66 Hz, 500 VA max.  
**Size/Weight**  
**Mainframe:** 234 mm H x 426 mm W x 537 mm D (9.36 in x 17.04 in x 21.48 in)/24.2 kg (53.24 lb)  
**Test Station:** 95 mm H x 275 mm W x 205 mm D (3.8 in x 11 in x 8.2 in)/3.7 kg (8.14 lb)

## Key Literature

4291B 1.8GHz Impedance/Material Analyzer Product Overview, p/n 5966-1501E  
 4291B 1.8GHz Impedance/Material Analyzer Technical Specifications, p/n 5966-1543E

## Ordering Information

**4291B RF Impedance/Material Analyzer**  
**Furnished Accessories:** High-Impedance Test Head, Calibration Kit, Operation Manual, Floppy Disk, and Power Cable. (No test fixture is supplied with the 4291B.)  
**Options**

- Opt 1D5** Add High-Stability Frequency Reference
- Opt 001** Add DC Bias
- Opt 002** Add Material Measurement Software
- Opt 011** Delete High-Impedance Test Head
- Opt 012** Add Low-Impedance Test Head
- Opt 013** Add High-Temperature High-Impedance Test Head
- Opt 014** Add High-Temperature Low-Impedance Test Head

### Support Options

- Opt W30** Extended Repair Service
- Opt W32** Calibration Service

### Accessories

- 16190A** Performance Test Kit
- 16191A** Side Electrode Test Fixture
- 16192A** Parallel Electrode Test Fixture
- 16193A** Small Side Electrode Test Fixture
- 16194A** High-Temperature Component Test Fixture
- 16196A/B/C** Parallel Electrode SMA Test Fixture
- 16197A** Bottom Electrode SMA Test Fixture
- 16453A** Dielectric Material Test Fixture
- 16454A** Magnetic Material Test Fixture

- Basic accuracy  $\pm 0.8\%$
- 3GHz impedance direct read-out
- Windows-styled user interface
- Sweep parameters (frequency, ac level, dc bias)
- Built-in VBA programming function
- Various test fixture for components
- Data transfer through the LAN interface
- Direct read-out permittivity, permeability [Option]



E4991A

### E4991A RF Impedance/Material Analyzer NEW

The new Agilent E4991A RF impedance/material analyzer offers ultimate impedance measurement performance and powerful built-in analysis function. It will provide innovations in R&D of components and circuit designers who evaluate components in the range of 3 GHz. The E4991A uses an RF-IV technique, as opposed to the reflection measurement technique, for more accurate impedance measurement over wide impedance range. Basic impedance accuracy is  $\pm 0.8\%$ . High Q accuracy enables low-loss component analysis. The internal synthesizer sweeps frequency from 1 MHz to 3 GHz with 1 mHz resolution.

#### Versatile Analysis

The E4991A enables display up to 3 scalar and 2 complex parameters. Engineer can easily observe the various impedance parameters. The list-sweep function improves test throughput by segmenting the sweep includes only necessary measurement frequencies. Test signal level ranges enable device evaluation under actual operating conditions. The DC bias, AC signal level swept measurement, and the monitor of test signal functions are available to the E4991A.

Internal VBA programming function is also useful for R&D in order to analyze component or material by using own analysis method. Furthermore, the built-in Equivalent Circuit Analysis Function automatically calculates the circuit constant values of five circuit models. These functions will drastically improve engineering productivity.

#### Material Evaluation

The E4991A provides the total dielectric/magnetic material measurement solutions in wide frequency range (1 MHz to 1 GHz). See page 492 for more information.

#### Ease of Use

The 8.4-inch color display and Windows-styled user interface is employed in the E4991A. Color display brings a clear view of measurement settings and results. Windows-styled menu gives you easy access to advanced features. The standard TCP/IP-compliant LAN interface realizes seamless connectivity with PC. With LAN capability, PC can directly read out measurement data from E4991A. It helps you to make documentation and share your test results with others.

#### Test Fixtures

Various test fixtures are available for the E4991A. Especially the 16196x family, Parallel electrode SMD test fixture, and 16197A, Bottom electrode SMD test fixture, are the new test fixtures for surface mount devices (SMDs) component. These fixtures are covering 3 GHz frequency range. (See page 488 for more information.) The E4991A replaces existing RF impedance material analyzer, 4291B. The E4991A is succeeding most of fundamental features of 4291B and additional new features are significantly improved usability.

#### Specifications

##### Measurement Parameters:

$|Z|, \theta_z, |Y|, \theta_y, R, X, G, B, C_s, C_p, L_s, L_p, R_p, R_s, D, Q, |\Gamma|, \Theta_r, \Gamma_x, \Gamma_y$

**Material Parameters:**  $|\epsilon_r|, \epsilon_r', \epsilon_r'', |\mu_r|, \mu_r', \mu_r'', \tan \delta$

**Basic Impedance Accuracy:** 0.8%

**Operating Frequency:** 1 MHz to 3 GHz

**Frequency Resolution:** 1mHz

**Frequency Reference Accuracy:**  $< \pm 10 \text{ ppm} @ 23^\circ \text{C} \pm 5^\circ \text{C}$

**Precision Frequency Reference:** (Opt. 1D5)

**Accuracy:**  $< \pm 1 \text{ ppm/year} @ 0^\circ \text{C} \text{ to } 55^\circ \text{C}$ , referenced to  $23^\circ \text{C}$

##### Source Characteristics

###### OSC Level:

4.47 mV to 477 mVrms

89.4  $\mu\text{A}$  to 8.94 mArms

**Display Level Unit:** V, I, dBm

**Level Monitor Function:** Voltage, Current

**Connector:** 7 mm

**Output Impedance (nominal value):** 50  $\Omega$

##### DC Bias

**DC Level:** 0 V to  $\pm 40 \text{ V}$ , 0 mA to  $\pm 50 \text{ mA}$

**DC Level Monitor Function:** Voltage, Current

##### Sweep Characteristics

**Sweep Parameter:** Frequency, AC signal level, DC bias level

##### Calibration/Compensation

**Calibration:** Open/Short/Load/Low-loss capacitor

**Compensation:** Open/Short, Port extension, Fixture electrical length

##### Key Specifications of Test Fixtures

Type of fixture	Operating freq. (typ.)	Operating temperature	DUT Size (L x W: mm)
16191A	DC to 2 GHz	$-55^\circ \text{C}$ to $+85^\circ \text{C}$	2.0 to 12.0
16192A	DC to 2 GHz	$-55^\circ \text{C}$ to $+85^\circ \text{C}$	1.0 to 20.0
16196A	DC to 3 GHz	$-55^\circ \text{C}$ to $+85^\circ \text{C}$	1.6 x 1.8 only
16196B	DC to 3 GHz	$-55^\circ \text{C}$ to $+85^\circ \text{C}$	1.0 x 0.5 only
16196C	DC to 3 GHz	$-55^\circ \text{C}$ to $+85^\circ \text{C}$	0.6 x 0.3 only
16197A	DC to 3 GHz	$-55^\circ \text{C}$ to $+85^\circ \text{C}$	1.0 to 3.2

##### Display

**CRT:** 8.4-inch color LCD display

**Number of Display Channel:** 1

**Format:** Single, dual, active + memory, graphic, and tabular

##### Storage/Programming functions

**Type:** Built-in 3 1/2-inch floppy disk drive, Internal HDD

**Disk Format:** DOS

**Programming:** VBA (Built-in)

##### Input and Output Characteristics

**External Reference Input:** 10 MHz  $\pm$  100 Hz (typical)

**Internal Reference Output:** 10 MHz nominal

**Reference Oven Output (Option 1D5):** 10 MHz nominal

**External Trigger Input:** BNC female, TTL Level

##### General Specifications

**Operating Temperature/Humidity:**  $5^\circ \text{C}$  to  $40^\circ \text{C}$  / 20% to 80% RH

**Warm-up Time:** 30 min

**Power Requirements:** 90 V to 132 V, or 198V to 264V, 47 Hz to 66Hz, 350 VA max.

**Size/Weight:**

**Mainframe:** 234 mm H x 426 mm W x 445 mm D (9.36 in x 17 in x 18.2 in) / 17.0 kg (37.44 lb)

**Test Station:** 64 mm H x 160 mm W x 160 mm D (2.56 in x 6.4 in x 6.4 in) / 0.9 kg (1.98 lb)

E4991A  
16196A/B/C  
16197A

## Key Literature

E4991A RF Impedance/Material Analyzer Product Overview, p/n 5980-1234E  
E4991A RF Impedance/Material Analyzer Technical Specification, p/n 5980-1233E

## Ordering Information

**E4991A** RF Impedance/Material Analyzer

### Furnished Accessories:

**16195B** 7mm Coaxial Calibration Kit, Operation Manual, Keyboard, Mouse, Floppy Disk, and Power Cable (No test fixture is furnished with E4991A).

### Options:

- Opt 001** Add DC Bias
- Opt 002** Add Material Measurement Firmware
- Opt 0B0** Delete Manual Set
- Opt 0B1** Add Manual Set
- Opt 1A2** Delete Keyboard
- Opt 1CS** Delete Mouse
- Opt 1D5** High Stability Frequency Reference
- Opt ABA** US-English Localization
- Opt ABJ** Japan-Japanese Localization
- Opt 1CM** Rack Mount Kit
- Opt 1CN** Front Handle Kit
- Opt 1CP** Handle/Rack Mount Kit

### New Accessories

**16196A/B/C** Parallel Electrode SMD Test Fixture (up to 3 GHz)  
**16197A** Bottom Electrode SMD Test Fixture (up to 3 GHz)

### Existing Accessories

**16190B** Performance Test Kit  
**16195B** 7mm Coaxial Calibration Kit  
**16191A** Side Electrode SMD Test Fixture (up to 2 GHz)  
**16192A** Parallel Electrode SMD Test Fixture (up to 2 GHz)  
**16194A** High Temperature Test Fixture (up to 2 GHz)  
**16092A** Test Fixture (up to 500 MHz)  
**16094A** Probe Test Fixture (up to 125 MHz)  
**16200B** External DC Bias Adapter (up to 1 GHz)  
**16453A** Dielectric Material Test Fixture (up to 1 GHz)  
**16454A** Magnetic Material Test Fixture (up to 1 GHz)

## RF SMD Test Fixtures

The following test fixtures can help you achieve the superior accuracy and measurement repeatability you need to evaluate surface mount devices (SMDs) up to 3 GHz.

### 16196A/B/C Parallel Electrode SMD Test Fixtures

The 16196A, 16196B, and 16196C are coaxial-structured high performance test fixtures for impedance measurements at frequencies up to 3 GHz. These fixtures are your best choice for the characterization of parallel electrode chip inductors and other passive RF components. The 16196A accommodates SMDs with the size code 1.6 mm x 0.8 mm. The 16196B handles SMDs that have the size code 1.0 mm x 0.5 mm. The 16196C is for size code 0.6 mm x 0.3 mm SMDs.



16196A/B/C

### 16197A Bottom Electrode SMD Test Fixture

The 16197A is designed for impedance evaluations of bottom electrode SMDs components up to 3 GHz. This test fixture accommodates various sizes of SMDs; as small as 1.0 mm x 0.5 mm and as large as 3.2 mm x 2.5 mm.

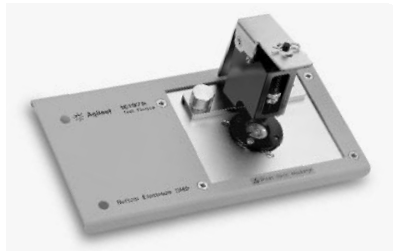

16197A

### Key Specifications of Test Fixtures

Type of fixture	Operating freq. (typ.)	Operating temperature	Applicable DUT electrode configuration	DUT Size (l x w = mm)
<b>16196A</b>	DC to 3 GHz	-55° C to +85° C	Parallel electrodes	1.6 x 0.8 only
<b>16196B</b>	DC to 3 GHz	-55° C to +85° C	Parallel electrodes	1.0 x 0.5 only
<b>16196C</b>	DC to 3 GHz	-55° C to +85° C	Parallel electrodes	0.6 x 0.3 only
<b>16197A</b>	DC to 3 GHz	-55° C to +85° C	Bottom electrodes	1.0 to 3.2

## Key Literature

Accessories Selection Guide for Impedance Measurement, p/n 5965-4792E

## Ordering Information

**16196A** Parallel Electrode SMD Test Fixtures  
**Opt 001** Delete a magnifying lens and tweezers  
**16196B** Parallel Electrode SMD Test Fixtures  
**Opt 001** Delete a magnifying lens and tweezers  
**16196C** Parallel Electrode SMD Test Fixtures  
**Opt 001** Delete a magnifying lens and tweezers  
**16197A** Bottom Electrode SMD Test Fixtures  
**Opt TBD**



- Accurate measurement over wide impedance range and wide frequency range
- Basic impedance accuracy:  $\pm 0.08\%$
- 40 Hz to 110 MHz, 3 m $\Omega$  to 500M $\Omega$
- Powerful impedance analysis function
- Ease of use and versatile PC connectivity

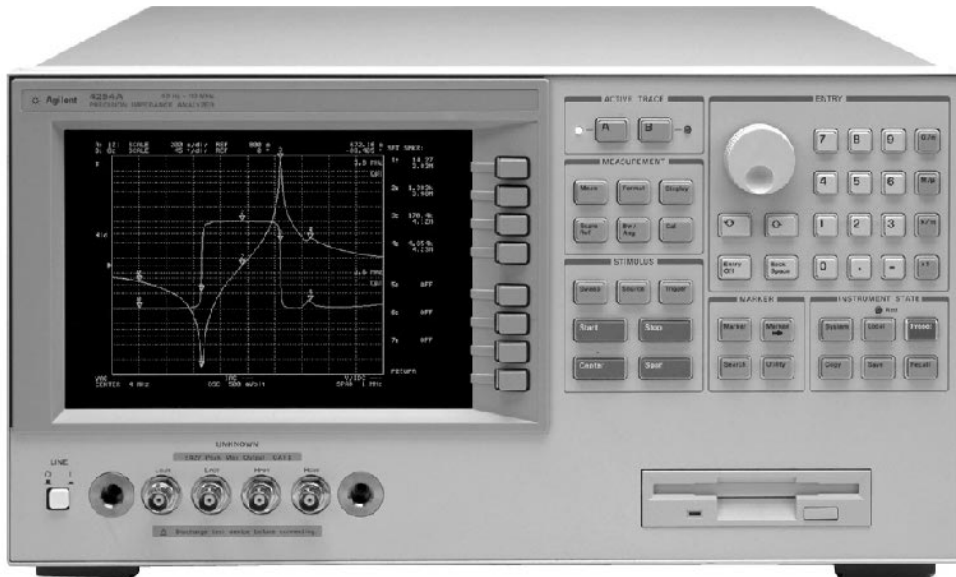

4294A

### 4294A Precision Impedance Analyzer



The Agilent 4294A Precision Impedance Analyzer is an integrated solution for efficient impedance measurement and analysis of components and circuits. The 4294A covers a broader test-frequency range (40Hz to 110MHz) with Basic impedance accuracy:  $\pm 0.08\%$ . Excellent High Q/Low D accuracy enables analysis of low-loss components. The wide signal-level ranges enable device evaluation under actual operating conditions. The test signal level range is 5mV to 1Vrms or 200 $\mu$ A to 20mA, and the DC bias range is 0V to  $\pm 40$ V or 0mA to  $\pm 100$ mA. Advanced calibration and error compensation functions eliminate measurement error factors when performing measurements on in-fixture devices. The 4294A is a powerful tool for design, qualification and quality control, and production testing of electronic components. Circuit designers and developers can also benefit from the performance/functionality offered.

#### Wide-Range Accurate Measurement

The 4294A enables impedance measurement using the auto-balancing bridge technique over the frequency range 40 Hz to 110 MHz. The basic impedance accuracy is  $\pm 0.08\%$ , and the typical Q accuracy is  $\pm 3\%$  @ Q=100,  $\leq 10$ MHz. This advantage permits accurate evaluations of impedance characteristics for a wide variety of electronic devices as well as electronic and non-electronic material within a wide frequency range.

#### Versatile Analysis

The 4294A graphically displays impedance measurement results. This permits easy analysis of the resonant frequency and impedance values of electronic components using the marker functions. The marker functions offer a simple method to pinpoint the resonant frequency of components, as well, these functions assist users in many other observations. The combination of the accumulate mode (to superimpose traces) and the list sweep functions permits observation of the change in a DUT's characteristics due to a change in the measurement condition. Versatile and high-speed automatic testing is possible using the list sweep function in conjunction with the limit line function. The list-sweep function provides the ability to enhance test throughput by segmenting the sweep to include only necessary measurement frequencies, while the limit-line function (for Go/No-Go Testing) provides the ability to apply test limits within each segment. These functions greatly support the quality and performance required evaluating modern and improved electronic components, equipment and materials.

#### Equivalent Circuit Analysis

The equivalent-circuit analysis function provides advanced modeling (three and four element models) based on circuit constant values of five available circuit models. This function simulates the frequency characteristics of components by using derived circuit values or user-specified values. Comparison of design values to measurement values can assist with efficient component design.

#### Programming

Full programmability is provided using built-in Instrument (IBASIC). Desired measurements and computations, including graphics analysis, can be programmed simply by storing front-panel keystroke operations. The one-key execution function allows easy selection and execution of customized IBASIC programs. Several forms of storage are built-in (10Mbyte no-volatile memory, RAM disk or Floppy Disk).

#### Good PC Connectivity

Features fit to the latest PC environment include LAN (Local Area Network) capability, VGA monitor output, and the TIFF file format. LAN capability permits simplified networking ability when collecting, sharing and analyzing data. VGA monitor output improves productivity and reduces eyestrain. TIFF file format allows easy transfer of graphics to a PC.

#### Abundance of Accessories

Various 4-terminal-pair test fixtures can be used with the 4294A. The 42941A Impedance Probe Kit (1.5m), which covers 40 Hz to 110 MHz, enables in-circuit impedance measurement of electronic circuits or components. Grounded devices can also be measured. The 42942A Terminal Adapter, which covers 40 Hz to 110 MHz, converts the 4-terminal-pair port configuration to a 7mm Test Port. This adapter permits the use of familiar 7mm test fixtures. Again, grounded measurement is available.

### Specifications

#### Measurement Parameters

$|Z|$ ,  $|Y|$ ,  $\theta$ , R, X, G, B, Cp, Cs, Lp, Ls, Rp, Rs, D, Q

#### Basic Measurement Accuracy

**Basic Impedance Accuracy (4 Terminal Pair):**  $\pm 0.08\%$   
(See figure in detail)

**Basic Impedance Accuracy with 42941A:**  $\pm 0.8\%$  (typical)

**Basic Impedance Accuracy with 42942A:**  $\pm 0.6\%$

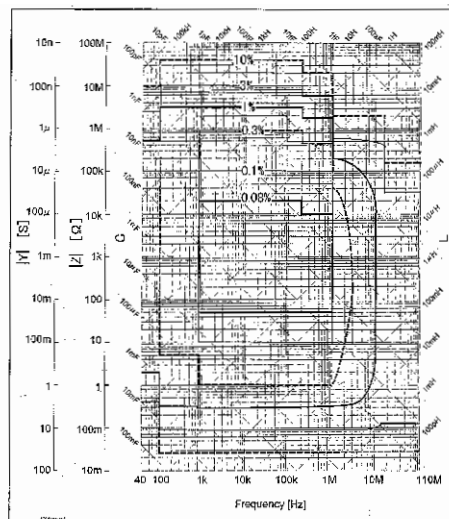

4294A Impedance Accuracy @4-Terminal-Pair, OSC=0.5V)

#### Source Characteristics

**Test Frequency:** 40 Hz to 110 MHz

**Frequency Resolution:** 1 mHz

**Frequency Accuracy:**

$\pm 20$  ppm ( $\pm 0.13$ ppm with Opt.1D5)

**OSC Level:** 5mV to 1V/200 $\mu$ A to 20mA

**OSC Level Resolution:** 1mV/20 $\mu$ A

**OSC Level Accuracy**

**Voltage:**  $\pm ((10+0.05 * f(\text{MHz}))\% + 1\text{mV})$  @ UNKNOWN Terminal OPEN

**Current:**  $\pm (10+0.3 * f(\text{MHz}))\% + 50\mu\text{A}$  @ UNKNOWN Terminal SHORT

**Level Monitor Function:** Voltage, Current

#### DC Bias

**DC Bias Level:** 0V to  $\pm 40$ V, 0A to  $\pm 100$ mA (Auto level control function available)

**DC Bias Level Resolution:** 1mV/40 $\mu$ A

**DC Bias Voltage Accuracy:**  $\pm (0.1\% + (5+30 * I_{\text{mon}}(\text{mA})))\text{mV}$

**DC Bias Current Accuracy:**  $\pm (2\% + (0.2 * V_{\text{mon}}(\text{V})/20)\text{mA}$

**DC Level Monitor Function:** Voltage, Current

#### Sweep Characteristic

**Sweep Parameter:** Frequency, AC voltage, AC current, DC bias voltage, DC bias current

**Sweep Type:** Linear, Log, List, Zero Span, Manual, Up/Down

**Number of Points:** 2 to 801

#### Calibration/Compensation/Adapter Type

**Calibration:** Open/Short/Load

**Compensation:** Open/Short/Load, port extension (electrical length)

**Adapter Type:** None, 1m, 2m, 7mm Adapter (42942A), Probe (42941A)

#### Display

**Size:** 8.4 inch

**Type:** Color LCD (TFT)

#### Analysis

**Marker:** 8 markers, delta marker function, search function, analysis function

**Equivalent Circuit Function:** Approximation, simulation

**Others:** IBASIC, Limit Line, Accumulate mode

#### Interface

**LAN Interface:** 10 Base-T Ethernet, RJ45 Connector, TCP/IP

**Other Interface:** GPIB Interface, Printer (Centronics), 8 bit I/O, 24 bit I/O, VGA monitor output

#### Storage

**Type:** Built-in 3.5inch floppy disk drive, 10 Mbyte non-volatile memory, 512kbyte volatile RAM disk memory

**Disk Format:** DOS

**Programming:** IBASIC

### General Specifications

**Operating Temperature and Humidity:** 0° C to 40° C, 15% to 80% RH  
**Power Requirements:** 90 V to 132 V, or 198V to 264 V, 47 Hz to 63 Hz, 300 VA Max.

**Size:** 222 mm H x 426 mm W x 502 mm D (8.88 in x 17.04 in x 20.08 in)

**Weight:** 25 kg (55 lb)

### 4294A Material Solution

The dielectric constant of a solid material can be measured with the 16451B dielectric test fixture. The magnetic constant of toroidal core can be also measured using the 16454A magnetic material test fixture with the 4294A/42942A configuration.

In both applications, the dielectric or magnetic constant is calculated from measured impedance value. The measurement sequence of impedance measurement, material constant calculation and data analysis can be automatically executed using built-in IBasic programming function.

The measurement program is provided as a sample programs in the 4294A operating manual. Users need to learn the IBASIC programming first, then the program can be modified as they like. The electronics knowledge is required to use these fixtures, because it is basically an impedance measurement.

**16451B Frequency Range when used with 4294A:**

40 Hz to 30 MHz

**16454A Frequency Range when used with 4294A:**

1 kHz to 110 MHz

**Applicable Material Size:** See page 492.

### Key Literature

4294A Precision Impedance Analyzer Profile, p/n 5968-3808E

4294A Technical Specification, p/n 5968-3809E

### Ordering Information

**4294A** Precision Impedance Analyzer

**Furnished Accessories:** Operation manual, floppy disk, and power cable. (No test fixture is supplied with the 4294A.)

**Opt 1D5** Add High-Stability Frequency Reference

**42941A** Impedance Probe Kit

**42942A** 7mm Terminal Adapter

**Opt 001** Delete 7mm Open/Short/Load set

**16047E** Test Fixture for axial lead components

**16034G** SMD Test Fixture

**16043A** 3-Terminal SMD Test Fixture (with slide)

**16043B** 3-Terminal SMD Test Fixture (without slide)

**16044A** Kelvin Contact SMD Test Fixture

**16048G** 1m Cable

**16048H** 1m Cable

**16451B** Dielectric Material Test Fixture

**16454A** Magnetic Material Fixture (used with 42942A)

- Accessories for characterizing the dielectric properties of materials
- Fast and convenient
- Wide frequency ranges from 30 kHz to 110 GHz
- Addition of markers
- Split screen view showing simultaneous plot and listing of data
- Ability to copy/paste menu items to other applications in plot or list format
- IEEE-488 instrument support – 82335, 82340, 82341, 82350, National Instruments cards
- On-line manual
- Compatible with the 8712E, 8752, 8753, 8719, 8720, 8722 and 8510 network analyzers
- Software runs on Windows 95, 98, or NT 4.0

### 85070C Dielectric Probe Kit

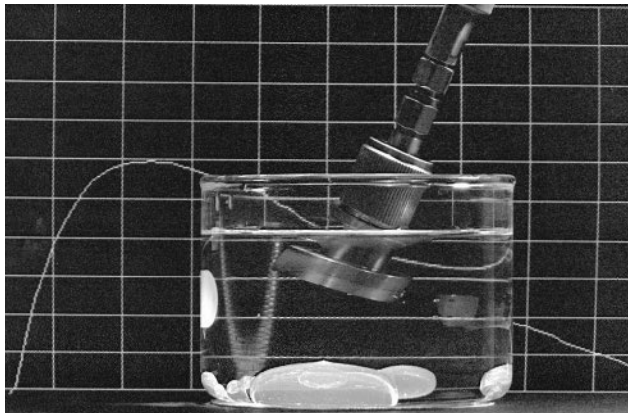

Measure the dielectric properties of materials quickly and conveniently with the 85070C dielectric probe. Measurements made with a probe-based system are nondestructive and require no sample preparation—saving you time, trouble, and material. The dielectric probe is well suited for measurements of liquid or semisolid materials. Simply immerse the probe into the material; there is no need for special fixtures. The dielectric probe is not recommended for thin (substrates) or low-loss (resonators) materials.

Knowledge of the dielectric loss of food, rubber, plastic, and ceramic products can assist researchers in the design and optimization of materials in microwave heating processes. Dielectric properties also correlate directly with other material properties—such as moisture content, phase transitions, molecular structure, polarizability, and relaxation constants. For example, this information has been useful in the development of microwaveable prepared foods.

A measurement system based on the 85070C dielectric probe yields permittivity (dielectric constant), loss factor, loss tangent, or Cole-Cole diagrams—versus frequency—from 200 MHz to 20 GHz (depending on the network analyzer and material). Measurement accuracy for the dielectric probe is typically five percent.

The 85070C high-temperature dielectric probe kit features a hermetic glass-to-metal seal, which makes it resistant to corrosive or abrasive chemicals. It withstands a wide  $-40^{\circ}\text{C}$  to  $+200^{\circ}\text{C}$  temperature range, which allows measurements versus frequency and temperature. This is an important variable, since the dielectric constant of a material can vary significantly as a function of temperature. A special refresh calibration simplifies measurements over temperature. The probe kit contains software and accessories including cables, port/cable adapters, switch, short circuit, mounting bracket, software, adapters, 50 ohm termination, stand, vials, and stoppers.

### 85071C Materials Measurement Software

Calculate the permittivity and permeability of material samples loaded into sections of coaxial airline or rectangular waveguide using the 85071C software. This measurement technique works well for solid materials that can be machined to fit precisely inside a transmission line.

A dielectric measurement can provide critical design parameter information for materials used in state-of-the-art RF and microwave electronic component applications. The loss of a cable or the impedance of a substrate can be related to its dielectric properties. This information is also useful for improving ferrite, radome, absorber, and packaging designs.

There are a variety of different measurement models to choose from in the 85071C software. A complete system requires the addition of a fixture (coaxial or waveguide transmission line), network analyzer, and controller. Measurement accuracies of one percent to two percent are typical from 100 MHz to 110 GHz (depending on the material, fixture, and network analyzer).

The standard version of the software runs on Windows 98 or NT.

### Other Solutions

Other measurement techniques based on RF or microwave network analyzers exist and offer their own unique advantages. For example, free-space methods are noncontacting and suitable to temperature extremes. (The 85071C materials measurement software is compatible with free-space measurements.) Resonator or cavity methods provide the highest accuracy and sensitivity to low-loss materials.

Below 30 MHz, the 16451B dielectric test fixture (coupled with an LCR meter or impedance analyzer) provides accurate low-frequency measurement of materials.

### Key Literature

85070C Dielectric Probe Kit Product Overview, p/n 5968-5330E

85071C Materials Measurement Software Product Overview, p/n 5968-5331E

### Ordering Information

**85070C** High-temperature dielectric probe kit  
Kit includes probe, software, cable, adapters, termination, shorting block, probe bracket, remote trigger and vials. Not included, but required is a computer and network analyzer.

**Opt 001** Adds probe stand (highly recommended)

**Opt 002** Adds high temperature cable

**Opt 070** Windows 95, 98 or NT 4.0 upgrade software (upgrade from any version of 85070 software)

**Opt 300** Substitutes 85070B HP Basic software

This option does not function with the 8712E network analyzer.

**Opt 370** HP Basic software upgrade to 85070B (revision 1.05)

**85071C** Materials measurement software

Windows 95, 98 or NT 4.0 compatible software. Not included, but required is a computer, network analyzer and fixtures or antennas to complete the system.

**Opt 071** Upgrade any 85071 to Windows 95, 98

or NT 4.0 85071C. Upgrade from any version of 85071 software.

**Opt 300** Substitutes 85071B HP Basic software.

This option does not function with the 8712E network analyzer.

**Opt 371** HP Basic software upgrade to 85071B (revision 1.05)

### Free Trial Demo

Evaluate a demo version of 85070C or 85071C software for up to four weeks. Visit Agilent Technologies website at [www.agilent.com/find/materials](http://www.agilent.com/find/materials) to download this demo program to your PC.

E9981A  
Option 002  
4291B  
Option 002  
E4991A  
16453A  
16454A

- Integrated system for permittivity and permeability measurement from 1 MHz to 1 GHz
- Versatile fixtures for substrate materials and toroids
- Built-in firmware for direct parameter measurement and easy data analysis



E4991A System (E4991A, 16453A, and 16454A)

## E4991A RF Impedance/Material Analyzer (Option 002 required) 4291B RF Impedance/Material Analyzer (Option 002 required)

The E4991A and 4291B RF impedance/material analyzers provide an easy and versatile material test solution from 1 MHz to 1 GHz. The analyzers measure impedance accurately and automatically calculate permittivity and permeability data from impedance. Various interchangeable test fixtures, designed specifically to work with the E4991A/4291B, let you measure dielectric materials and magnetic materials easily.

### 16453A Dielectric Test Fixture

The 16453A dielectric test fixture is best used for measuring substrate materials (solid, sheet material samples) less than 3 mm in thickness such as PC boards, substrates, and polymer materials. When used with the 16453A, the firmware (E4991A/4291B Option 002) built into the analyzer automatically calculates permittivity parameters. The flexible firmware also lets you display data as a Cole-Cole plot or find relaxation time.

### 16454A Magnetic Test Fixture

For permeability analysis, the 16454A magnetic test fixture is designed for testing toroidal-shaped samples up to 20 mm in diameter. An example of suitable materials-under-test is soft ferrite magnetic core. The 16454A comes with different sizes of sample holders for different toroid sizes for maximum flexibility. Built-in firmware (E4991A/4291B Option 002) automatically computes permeability parameters, eliminating cumbersome coil-winding or lengthy calculation.

### Temperature Coefficient Testing

Both 16453A and 16454A have an operating temperature range from -55° C to +200° C. Two hardware options are available for interfacing the fixtures to a temperature chamber. Choose the 4291B Option 013 high-temperature, high-impedance test head for the 16453A, or the 4291B Option 014 high-temperature, low-impedance test head for the 16454A.

## Specifications

**E4991A Option 002**  
**4291B Option 002**

Material Parameters:  $|\epsilon_r|, \epsilon_r', \epsilon_r''$ ;  $|\mu_r|, \mu_r', \mu_r''$ ;  $\tan \delta$   
Operating Frequency: 1 MHz to 1 GHz

### 16453A Dielectric Test Fixture

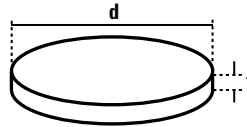

**Sample Material Specifications**  
t: 0.3mm ≤ t ≤ 3mm  
d: ≥ 15mm

NOTE: Material surface should be flat and parallel.

**Operating Frequency Range:** 1 MHz to 1 GHz  
**Operating Temperature Range:** -55° C to +200° C

### 16454A Magnetic Test Fixture

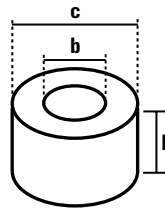

#### Sample Material Specifications

Fixture Holder	Small A	B	Large C	D
c	≤ 8 mm	≤ 6 mm	≤ 20 mm	≤ 20 mm
b	≤ 3.1 mm	≤ 3.1 mm	≤ 6 mm	≤ 5 mm
h	≤ 3 mm	≤ 3 mm	≤ 8.5 mm	≤ 8.5 mm

**Operating Frequency Range:** 1 MHz to 1 GHz  
**Operating Temperature Range:** -55° C to +200° C

## Key Literature

E4991A RF Impedance/Material Analyzer Product Overview, p/n 5980-1234E

4291B RF Impedance/Material Analyzer Product Overview, p/n 5966-1501E

Permittivity Measurements of PC Board and Substrate Materials using the 4291B and 16453A, AN Application Note 1300-3, p/n 5966-1844E

Permeability Measurements using the 4291B and 16454A, AN application Note 1300-4, p/n 5966-1844E

## Ordering Information

**E4991A** RF Impedance/Material Analyzer

**Opt 002** Material Measurement Firmware

**4291B** RF Impedance/Material Analyzer

**Opt 002** Material Measurement Firmware

**Opt 013** High-Temperature, High-Impedance Test Head

**Opt 014** High-Temperature, Low-Impedance Test Head

**16453A** Dielectric Test Fixture

**16454A** Magnetic Test Fixture



- For measuring capacitance or dielectric constant of solid materials
- Designed for four-terminal-pair LCR meters or impedance analyzers

- For measuring capacitance or dielectric constant of liquids
- Designed for four-terminal-pair LCR meters or impedance analyzers

16451B  
16452A

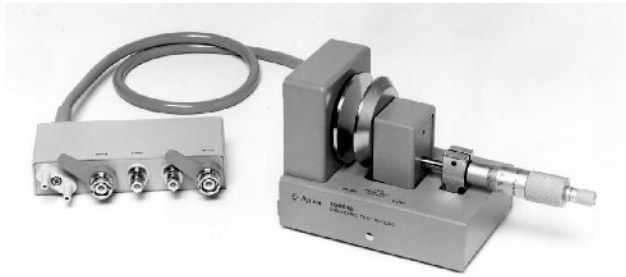

16451B Dielectric Test Fixture

### 16451B Dielectric Test Fixture

For dielectric constant evaluation of solid materials such as polymer, electric insulator, PC board, ceramic substrate, etc., use the 16451B dielectric test fixture with any Agilent four-terminal-pair LCR meter or impedance analyzer up to 30 MHz. The 16451B has four types of electrodes which can be replaced according to sample size or measurement technique. Stray admittance and residual impedance of the test fixture can be eliminated by the OPEN/SHORT error correction function of the measurement instrument by using the furnished OPEN/SHORT attachments.

#### Specifications

**Frequency Range:**  $\leq 30$  MHz (depends on instruments)

**Operating Temperature:**  $0^{\circ}\text{C}$  to  $+55^{\circ}\text{C}$

**Sample Size:** Diameter 10 to 56 mm, Thickness  $\leq 10$  mm

**Parameters:** Capacitance, Loss Tangent,  $\epsilon_r'$ ,  $\epsilon_r''$  (must be calculated using external computer or IBASIC)

**Electrical Interface:** Four-terminal pair

#### Key Literature

16451B Dielectric Test Fixture Data Sheet, p/n 5950-2368  
Dielectric Constant Measurements Using the 16451B Test Fixture, p/n 5962-9522E

#### Ordering Information

**16451B** Dielectric Test Fixture



16452A Liquid Test Fixture

### 16452A Liquid Test Fixture

For convenient testing of liquids, use the 16452A liquid test fixture with any four-terminal-pair LCR meter or impedance analyzer. With the 16452A, you will be able to measure permittivity and impedance characteristics of liquid materials like plastic resins, or petrochemical products. The fixture has inlet/outlet ports which allow continuous measurements of liquids flowing in a process monitoring environment. The internal cell allows accurate measurements to be performed on a small amount of liquid samples.

#### Specifications

**Operating Frequency:** 20 Hz – 30 MHz

**Operating Temperature:**  $-20^{\circ}\text{C}$  to  $+125^{\circ}\text{C}$

**Sample Size:** 3.4 ml to 6.8 ml

**Parameters:** Capacitance, Loss Tangent,  $\epsilon_r'$ ,  $\epsilon_r''$  (must be calculated using external computer or IBASIC)

**Electrical Interface:** Four-terminal pair

Note: The 16452A is not capable of measuring salt or ionic solutions, or other liquids with bulk conductivity due to the electrode polarization phenomenon.

#### Key Literature

16452A Liquid Test Fixture Data Sheet, p/n 5091-9228E

#### Ordering Information

**16452A** Liquid Test Fixture

Recommended measurement cables for connecting the 16452A to an Agilent four-terminal-pair LCR meter or impedance analyzer: 16048A Test Lead ( $0^{\circ}\text{C}$  to  $+55^{\circ}\text{C}$ ), 16452-61601 ( $-20^{\circ}\text{C}$  to  $+125^{\circ}\text{C}$ ), or 16048G Test Lead ( $-20^{\circ}\text{C}$  to  $150^{\circ}\text{C}$ , only for 4294A)

- 0.1% basic accuracy
- 100 Hz, 120 Hz, 1 kHz, 10 kHz, 100 kHz test frequencies
- 20 mV to 1 Vrms in 5m Vrms steps
- Test signal level monitor function
- High-speed measurement: 25 ms
- High-speed contact check
- Wide capacitance test range
- Transformer parameter measurements (optional)



4263B

## 4263B LCR Meter



The 4263B LCR meter is Agilent Technologies' most cost-effective low-end LCR meter, designed for both component evaluation on the production line and fundamental impedance testing for bench-top applications. The 4263B has five test frequencies that allow you to simulate testing under the correct conditions: 100 Hz, 120 Hz, 1 kHz, 10 kHz, and 100 kHz. An optional 20 kHz test frequency can be added to those five frequencies (Option 002).

### High-Speed Measurements

The 4263B can boost throughput with a measurement speed of 25 ms at any test frequency. This ability improves the throughput of electrolytic capacitor and transformer testing. The 4263B can check the contact condition between the test terminals and the device-under-test (DUT). This function ensures the reliability of PASS/FAIL testing with automatic handlers in production. The quick recovery system of the 4263B improves throughput. Normal operation is resumed the instant a faulty DUT is removed from the handler, so the handler can always be operated at its full speed.

### Electrolytic Capacitor Measurements

The 4263B's accuracy and wide measurement range are the right tools to make precise measurements of electrolytic capacitors. Charged capacitors can discharge through the front end and destroy an instrument. The 4263B's front end is designed for protection and maintains test integrity.

### Transformer Parameter Measurements

With the 4263B's ability to make turns ratio (N), mutual inductance (M), and dc resistance (DCR) measurements, data calculations and changing test setups are no longer time-consuming tasks (Option 001). The flexible signal level setting and the voltage-and-current monitor function facilitate the use of the 4263B for level dependent DUTs, such as core inductors.

### Specifications

(Refer to Product Overview for complete specifications.)

#### Measurement Functions

**Measurement Parameters:**  $Z$ ,  $Y$ ,  $\theta$ , R, X, G, B, L, C, Q, D, ESR

**Option 001:** Add DCR (dc resistance), N (turns ratio), and M (mutual inductance) measurement

**Measurement Circuit Mode:** Series and parallel

**Mathematical Functions:** Deviation and percent deviation

**Test Cable Lengths:** 0 m, 1 m, 2 m, 4 m (freq. = 100/120/1k Hz);

0 m, 1 m, 2 m (freq. = 10k/20k Hz); 0 m, 1 m (freq. = 100 kHz)

#### Test Signal Information

**Test Frequency:** 100 Hz, 120 Hz, 1 kHz, 10 kHz, and 100 kHz

**Option 002:** Add 20 kHz test frequency

**Frequency Accuracy:**  $\pm 0.01\%$  (freq. = 100 Hz, 1 kHz, 10 kHz, 20 kHz, 100 kHz),  $\pm 1\%$  (freq. = 120 Hz)

**Output Impedance:**  $100 \Omega \pm 10\%$ ,  $25 \Omega \pm 10\%$  ( $\leq 1 \Omega$  range)

**AC Test Signal Level:** 20 mV to 1 Vrms in 5m Vrms steps

**Accuracy:**  $\pm (10\% + 10 \text{ mV})$

#### Internal dc Bias

**Level:** 1.5 and 2 V; **Accuracy:**  $\pm (5\% + 2 \text{ mV})$

**External dc Bias:** 0V to +2.5 V

### Measurement Range

Parameter	Measurement range
$Z$ , R, X	1 m $\Omega$ to 100 M $\Omega$
$Y$ , G, B	10 nS to 1000 S
C	1 pF to 1 F
L	10 nH to 100 kH
D	0.0001 to 9.9999
Q	0.1 to 9999.9
$\theta$	-180° to +180°
DCR	1 m $\Omega$ to 100 M $\Omega$
N	0.9 to 200 (unspecified)
L, M	1 $\mu$ H to 100 H (unspecified)
$\Delta\%$	-999.99% to +999.99%

**Measurement Accuracy:**  $\pm 0.1\%$  (basic) (for  $Z$ , R, X,  $Y$ , G, B, C, L)

### Measurement Time

Mode	Time (typical)
SHORT	25 ms
MEDIUM	65 ms
LONG	500 ms

**Test Signal Level Monitor:** Voltage and current

**Front-End Protection:** Internal circuit protection when a charged capacitor is connected to the input terminals. The maximum capacitor voltage is:  $V_{max} = \sqrt{8/C}$  (typical) @  $V_{max} \leq 250 \text{ V}$ ;  $V_{max} = \sqrt{2/C}$  (typical) @  $V_{max} \leq 1000 \text{ V}$ , C is in Farads.

**Display Digits:** 3, 4, or 5 (selectable)

#### Correction Function

**Zero OPEN/SHORT:** Eliminates measurement errors due to stray parasitic impedances in the test fixtures.

**Load:** Improves measurement accuracy by using a calibrated device as a reference.

**Comparator Function:** HIGH/IN/LOW for each primary measurement parameter and secondary measurement parameter.

**Contact Check Function:** Contact failure between the test fixture and device can be detected. Additional time for contact check: 5 ms.

#### Other Functions

**Save/Recall:** Ten instrument setups can be saved/recalled from the internal nonvolatile memory.

**Continuous Memory Capability:** If the instrument is turned off, or if a power failure occurs, instrument settings (except dc bias on/off) are automatically memorized ( $\leq 72$  hours at  $23^\circ \text{ C} \pm 5^\circ \text{ C}$ ).

**GPIB Interface:** All control settings, measured values, and comparator information.

**Handler Interface:** All output signals are negative-logic, optically isolated open collectors. Output signals include HIGH/IN/LOW, no contact, index, end of measurement, and alarm. Input signals include keylock and external trigger.

### General Specifications

**Power Requirements:** 90 to 132 V or 198 to 264 V, 47 to 66 Hz, 45 VA max.

**Operating Temperature:** 0° C to 45° C

**Size:** 100 mm H x 320 mm W x 300 mm D (3.94 in x 12.6 in x 11.81 in)

**Weight:** 4.5 kg (9.9 lb)

### Key Literature

4263B LCR Meter Product Overview, p/n 5964-6181E

Effective Electrolytic Capacitors Testing, p/n 5967-5378E

Effective Transformer/LF Coil Testing, p/n 5967-5377E

### Ordering Information:

#### 4263B LCR Meter

**Opt 001** Add Transformer Parameter Measurement Function

**Opt 002** Add 20kHz Test Frequency

**Opt ABA** US-English Localization

**Opt ABJ** Japan-Japanese Localization

**Opt 0B0** Delete Manual Set

**Opt W30** Extended Repair Service

**16060A** Transformer Test Fixture (Option 001 Required)

**16065C** External Bias Adapter (up to 40Vdc)

**16034G** Small SMD Test Fixture (0603[mm]/0201[in] SMD)

**16044A** Kelvin Contact SMD Test Fixture

**16047A** 4-Terminal Contact Lead Component Test Fixture

**16047E** 2-Terminal Contact Lead Component Test Fixture

**16334A** Tweezers Contact SMD Test Fixture

**16064B** Comparator LED Display/Trigger Box

- 20 Hz to 1 MHz, with over 8,600 test frequencies
- 0.05% basic accuracy, 6-digit resolution
- Constant V or I test signal level
- 20 Vrms level option (Option 001)
- 40 Adc with 42841A
- List sweep measurement capability

- 75 kHz to 30 MHz in 100 Hz steps
- 0.1% basic accuracy
- High-speed measurements: 30 ms/meas.
- Constant V or I test signal level
- 10 Adc with 42841A
- List sweep measurement capability

4284A  
4285A



4284A

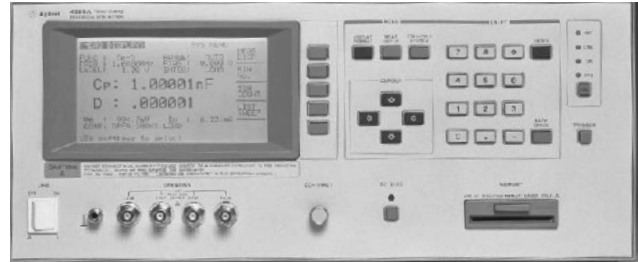

4285A

### 4284A, 4285A Precision LCR Meters



The Agilent 4284A and 4285A precision LCR meters are cost-effective solutions for component and material measurement. They can be used to improve component quality by providing an accurate, high-throughput test solution. The wide 20 Hz to 1 MHz test frequency range and superior test-signal performance allow the 4284A to test components to the most commonly-used test standards, such as IEC/MIL standards, and under conditions that simulate the intended application. For demanding RF component tests, the 4285A offers a higher test-frequency range, from 75 kHz to 30 MHz. Whether in research and development, production, quality assurance, or incoming inspection, the 4284A and 4285A will meet all of your LCR meter test and measurement requirements.

#### Specifications

(Refer to Data Sheet for complete specifications.)

**Measurement Parameters:**  $Z$ ,  $Y$ ,  $\theta$ , R, X, G, B, L, C, D, Q, ESR; Deviation and % deviation

**Measurement Circuit Modes:** Series and parallel

**Ranging:** Auto and manual

**Trigger:** Internal, external, manual, and bus (GPIB)

**Delay Time:** 0s to 60.000s in 1 ms steps

**Measurement Terminals:** 4-terminal pair

**Test Cable Length:**

4284A: Standard: 0 and 1 m; with Option 006: 0, 1, 2 and 4 m

4285A: 0, 1 and 2 m

**Integration Time:** Short, medium, and long

**Averaging:** 1 to 256, programmable

**Test Signal:**

4284A: 20 Hz to 1 MHz  $\pm$  0.01%, 8610 selectable frequencies

4285A: 75 kHz to 30 MHz  $\pm$  0.01%, 100 Hz steps

**Test Signal Modes:**

**Normal:** Programs selected voltage or current at the measurement terminals open or shorted, respectively, and not at the device-under-test.

**Constant:** Maintains selected voltage or current at the device-under-test independent of changes in the device's impedance.

Test Signal Levels (rms)	Normal	Constant
4284A	5 mV to 2 V, 50 $\mu$ A to 20 mA	10 mV to 1 V, 100 $\mu$ A to 10 mA
Option 001	5 mV to 20 V, 50 $\mu$ A to 200 mA	10 mV to 10 V, 100 $\mu$ A to 100 mA
4285A	5 mV to 2 V, 200 $\mu$ A to 20 mA	10 mV to 1 V, 100 $\mu$ A to 20 mA

**DC Bias:**

4284A Standard: 0 V, 1.5 V and 2 V

4284A/4285A Option 001: 0 V to  $\pm$  40 V

#### Measurement Display Range

Parameter	Range
$Z$ , R, X	0.01 m $\Omega$ to 99.9999 M $\Omega$
$Y$ , G, B	0.01 nS to 99.9999 S
C	4284A: 0.01 fF to 9.9999 F 4285A: 0.01 fF to 999.999 $\mu$ F
L	4284A: 0.01 nH to 99.9999 kH 4285A: 0.001 nH to 99.9999 H
D	0.000001 to 9.99999
Q	0.01 to 99999.9
$\theta$	-180.000° to 180.000°
$\Delta\%$	-999.999% to 999.999%

#### Basic Measurement Accuracy

	$Z$ , C, L	D
4284A	0.05%	0.0005
4285A	0.1%	0.001

@ 23° C  $\pm$  5° C, after OPEN and SHORT correction

#### Supplemental Characteristics

**Measurement Time:** Typical measurement time from the trigger command to the end of measurement (EOM) output at the handler interface connector

	4284A at 1 KHz	4285A 75 kHz to 30 MHz
SHORT	40 ms	30 ms
MEDIUM	190 ms	65 ms
LONG	830 ms	200 ms

**Option 001 DC Bias Current Output:** 100 mA max.

#### Display

**LCD dot-matrix display:** Displays measured values, control settings, comparator limits and decisions, list sweep tables, self-test messages, and annunciations.

#### Correction Function

**Zero OPEN/SHORT:** Eliminates measurement errors due to the test fixture's stray parasitic impedance.

**Load:** Improves measurement accuracy by using a calibrated device as reference.

#### List Sweep Function

A maximum of ten frequencies or test signal levels can be programmed. Single or sequential testing can be performed. When Option 001 is installed, dc voltage bias testing can also be performed.

4192A  
4284A  
4285A

## Comparator

Ten-bin sorting for the primary measurement parameter. IN/OUT for the secondary measurement parameter.

**Bin Count:** 0 to 999999

**List Sweep Comparator:** HIGH/IN/LOW decision output for each measurement point in the list sweep table

## Other Functions

**STORE/LOAD:** Ten instrument setups can be stored/loaded from the internal non-volatile memory. Ten additional setups can also be stored/loaded from a memory card.

**GPIB:** All instrument control settings, measured values, comparator limits, list sweep table, and self-test results.

**Memory:** The memory buffer can store a maximum of 128 measurement results and output the data over GPIB, ASCII, and 64-bit binary data formats.

## General Specifications

**Power Requirements:** 100/120/220 V  $\pm$  10%, 240 V 5%/-10%, 47 to 66Hz

**Power Consumption:** 200 VA max.

**Operating Temperature and Humidity:** 0° C to 55° C,  $\leq$  95% RH at 40° C

**Size:** 177 mm H x 426 mm W x 498 mm D (6.97 in x 16.77 in x 19.61 in)

**Weight:** Approximately 16 kg (35.2 lb)

## Accessories

### 42841A Bias Current Source

**Bias Current Output:** (23° C  $\pm$  5° C): 0.01 A–20.0 A

**Basic Impedance Accuracy:** 1% when used with the 4284A/4285A (1 kHz to 1 MHz)

**Interface:** Custom, directly controllable by the 4284A/4285A with Option 002

### 42842A/B Bias Current Test Fixture

Used with the 4284A and 42841A for high dc bias current measurements:

**42842A:** 20 A max.

**42842B:** 40 A max.

### 42842C Bias Current Test Fixture

Used with the 4285A and 42841A for high dc bias current measurement. 10 A max.

### 42843A Bias Current Cable

Used with the 4284A, 42841A (2 units), and 42842B for 40 A maximum applications (necessary for I<sub>dc</sub> > 20A)

## Ordering Information

**4284A** Precision LCR Meter

**4285A** Precision LCR Meter

**Opt 001** Power Amplifier/DC Bias (4284A)

DC Bias (4285A)

**Opt 002<sup>1</sup>** Bias Current Interface (4284A)

Accessory Control Interface (4285A)

**Opt 004<sup>2</sup>** Memory Card (4284A)

**Opt 004<sup>2</sup>** Memory Card (4285A)

**Opt 006** 2m/4m Cable Length Operation (4284A only)

**Opt 109** Delete GPIB Interface(both)

**Opt 201** General Purpose Handler Interface(both)

**Opt 202** Handler Interface(both)

**Opt 301** Scanner Interface(both)

**42841A** Bias Current Source

**42842A** Bias Current Test Fixture (20A max.)

**42842B** Bias Current Test Fixture (40A max.)

**42842C** Bias Current Test Fixture (10A max.)

**Opt 001** SMD Test Fixture (42842C only)

**42843A** Bias Current Cable

<sup>1</sup>Options 001 and 002 do not operate simultaneously.

<sup>2</sup>Common options

- 5 Hz to 13 MHz variable frequency
- Gain-phase measurement: amplitude, phase, group display
- Floating or grounded devices
- Impedance measurement: |Z|, |Y|,  $\theta$ , R, X, G, B, L, C, D, Q,  $\Delta$ ,  $\Delta\%$
- Standard GPIB



4192A (shown with Option 907 handles)

## 4192A LF Impedance Analyzer

GPIB

### Specifications

(Refer to data sheet for complete specifications.)

**Frequency Range:** 5 Hz to 13 MHz

**OSC Level:** 5 mV to 1.1 mV

**DC Bias:** 0V/35V

**Measurement Range:** 1.0000  $\Omega$  to 1.000M $\Omega$

**Basic Accuracy:** 0.15%

### Ordering Information

**4192A** LF Impedance Analyzer



4284A with 42841A and 42842A

## Key Literature

4284A/4285A Precision LCR Meter Family Data Sheet, p/n 5963-5391E

4284A Technical Data, p/n 5963-5390E

4285A Technical Data, p/n 5963-5395E

LCR Meters, Impedance Analyzers and Test Fixtures Selection Guide, p/n 5952-1430E



- 1 MHz to 3 GHz, with 100 kHz steps
- Wide impedance measurement range from 200 mΩ to 3 kΩ
- Superior measurement repeatability at low test signal level
- 1% basic accuracy
- High-speed measurements: 9 ms



4287A with the 16196A

4287A

### 4287A RF LCR Meter



The Agilent 4287A RF LCR meter offers accurate, reliable and fast measurements from 1 MHz to 3 GHz to improve quality and throughput of electronic component testing in production lines. The 4287A employs the direct-current voltage-measurement technique, as opposed to the reflection-measurement technique, which yields accurate measurements over a wide impedance range.

### High Throughput and Reliable Measurement

The 4287A is suitable for testing electronic components in the RF range. The 4287A's measurement speed is remarkably fast. In addition, the superior measurement repeatability at low test currents such as 100μA provides a fast throughput since less averaging is required.

### Simplified System Integration

The test head cable (1m or 2m by using extension cable) can be easily connected closely to the tip of the device-under-test (of the component handler) without any increase in error. The built-in comparator function, a high-speed GPIB interface, and an handler interface, are available for simple integration with the component handler and PC. The enhanced comparator function makes sophisticated binning possible for multi-frequency or array chip testing.

### Ease of Use

The 8.4-inch color display provides a clear view of measurement settings and results. The newly developed user interface makes operability easy and error-free. The built-in statistical analysis functions provide a process for monitoring test quality and efficiency. The LAN interface helps centralize production control and monitor. Also, a number of 7mm SMD test fixtures can be used with the 4287A's furnished fixture stand and 3.5mm-to-7mm adapter, eliminating the need to build custom fixtures.

### Specifications

(Refer to Data Sheet for complete specifications)

**Measurement Parameters:** |Z|, |Y|, θ-z (deg/rad), θ-y (deg/rad), G, B, Ls, Lp, Cs, Cp, Rs, Rp, Q, D (Four Meas.Parameters can be displayed at the same time.)

**Test Frequency:** 1 MHz to 3 GHz

**Frequency Resolution:** 100 kHz

**Test Signal:**

V: 4.47 mV to 502 mV @f ≤1GHz, 4.47 mV to 447 mV @f >1 GHz

I: 0.0894 mA to 10 mA @f ≤1GHz, 0.0894 mA to 8.94 mA @f >1 GHz

**Level Monition Function:** Voltage, Current

**Basic Z Accuracy:** ±1.0%

**Measurement Range:** 200 mΩ to 3 kΩ (@1 MHz, accuracy ≤ 10%)

**Measurement Time:** 9msec per point (max.speed)

**Rdc Measurement:** Available for contact check

**Calibration:** Open/Short/Load/Low Loss Capacitor

**Compensation:** Open/Short, Electrical Length

**Mass Storage Function:** 30MB solid-state mass-storage or 2GB HDD (Option Selection)

**Interface:** GPIB, LAN (10Base-T/100Base-Tx Automatic Selection), Handler Interface

**Display:** 8.4 inch color LCD display

### General Specifications

**Power Requirements:** 90 V to 132 V, or 198 V to 264 V, 47 Hz to 63 Hz, 350 VA max.

**Operating Temperature/Humidity:** 5° C to 40° C/20%RH to 80%RH

**Size:** 234 mm H x 425 mm W x 445 mm D (9.36 in x 17 in x 17.8 in) (Main Frame)

**Weight:** 16 kg/0.3 kg (35.2 lb/.66 lb) (typical) (Main Frame/Test Head)

### Key Literature

4287A RF LCR Meter Product Overview, p/n 5968-5443E

4287A Technical Specifications, p/n 5968-5758E

LCR Meters, Impedance Analyzers, and Test Fixtures Selection Guide, p/n 5952-1430E

### Ordering Information

**4287A RF LCR Meter**

Furnished Accessories: Test Head (1m), 3.5mm-7mm Adapter, 16195B Calibration Kit, Mouse, Keyboard, Operation Manual, and Power Cable. (No test fixture is supplied with the 4287A.)

### Options

**Opt 001** Delete 16195B Calibration Kit

**Opt 002** Delete Test Fixture Stand

**Opt 003** Delete 3.5mm-7mm Adapter

**Opt 004** Add Working Standard Set

**Opt 010** Hard Disk Drive Mass Storage

**Opt 011** Solid-State Mass Storage

**Opt 020** Add Cable Extension Set

### Accessories Available

**16190B** Performance Test Kit

**16195B** 7mm Calibration Kit

**16191A** Side Electrode SMD Fixture

**16192A** Parallel Electrode SMD Fixture

**16193A** Small Side Electrode SMD Fixture

**16194A** High Temperature Test Fixture

**16196A** Parallel Electrode SMD Fixture for 1608 (mm)

**16196B** Parallel Electrode SMD Fixture for 1005 (mm)

**16196C** Parallel Electrode SMD Fixture for 0603 (mm)

**16197A** Bottom Electrode SMD Fixture

4268A  
4278A  
4288A

- High speed measurement: 7ms
- Accurate C-D testing: 0.075%, 0.0006
- Small cabinet size

- Constant test level for high value ceramic capacitor tests
- High speed measurement: 25 ms
- Quick contact check
- 9-bin comparator



4288A



4268A

### 4288A 1kHz/1MHz Capacitance Meter NEW

The Agilent 4288A 1kHz/1MHz capacitance meter offers a high-speed with reliable measurements for capacitor testing in the production lines. The measurement capabilities of capacitance from low to middle values (up to 20μF) can be realized with accurate measurements. The 4288A contributes improvements of the test throughput, while attaining excellent component quality for ceramic capacitor testing.

#### Specifications

**Measurement Parameters:** Cs, Cp, D, Q, Rs, Rp, G  
**Test Frequency:** 1 kHz and 1 MHz (–1%, +1%, +2% frequency shift available)  
**Test Signal Level:** 0.1 to 1Vrms, ±10% in 0.1Vrms steps  
**Measurement Range**

Measurement Parameter	1kHz	1MHz
C	0.001pF to 20.000μF	0.00001pF to 1500.00pF
D	0.00001 to 9.99999	0.00001 to 9.99999

**Measurement Time:** 7ms, 19ms (typical)  
**Cable Length Compensation:** 0m, 1m, 2m  
**Comparator:** 9 bin output to Handler Interface  
**Interface:** Handler, GPIB, and Scanner interface

#### General Specifications

**Operating Temperature/Humidity:** 0° C to 45° C, ≤95%RH@40° C  
**Power:** 90VAC to 132VAC, 198VAC to 264VAC, 47Hz to 66Hz, 100VA max.  
**Size:** 100mm H x 320mm W x 300mm D (4 in x 12.8 in x 12 in)  
**Weight:** Approximately 3kg (6.6 lb)

### Ordering Information

4288A 1kHz/1MHz Capacitance Meter

#### Accessories Available

- 16034E Chip Component Test Fixture
- 16034G Chip Component Test Fixture
- 16334A Tweezer-Type Test Fixture
- 16048A Test Leads, BNC (1m)
- 16048B Test Leads, SMC (1m)
- 16048D Test Leads, BNC (2m)

POA = Price on application

### 4278A 1kHz/1MHz Capacitance Meter GPIB

The 4278A 1kHz/1MHz capacitance meter offers high-speed and reliable measurements. The 4278A will improve test efficiency by performing comparative measurements of low to medium value capacitors (up to 200 μF).

### 4268A 120 Hz/1 kHz Capacitance Meter

The 4268A capacitance meter offers the ability to test high value multi-layer ceramic capacitors at a constant large test signal level and at high speed. The constant test level feature allows the MLCCs to be tested, in compliance with IEC 384-10 standard, for up to 70 μF at 1 V rms at 1 kHz. 120 Hz measurement ensures the constant 1 V test signal for up to 600 μF. The 4268A can provide measured values along with comparator results within 25 ms, maximizing test throughput in MLCC production lines.

#### Major Specifications

**Measurement parameters:** Cs, Cp, D, Q, Rs, Rp, G  
**Test Frequency:** 120 Hz and 1 kHz  
**Test Signal Level:** 0.1 V to 1 V rms, ±10%, in 0.01 V rms steps  
**Measurement Range**

Measurement Parameter	120Hz	1kHz
C	0.001nF to 9.9999mF	0.0001nF to 999.99μF
D	0.0001 to 9.9999	0.0001 to 9.9999

#### Constant Test Level Range (Typical)

Test Voltage	120 Hz	1 kHz
0.5 V rms	C ≤ 1200 μF	C ≤ 140 μF
1 V rms	C ≤ 600 μF	C ≤ 70 μF

**Measurement Time:** 25 ms/43 ms/59 ms (typical)  
**Contact Check:** Detects contact failure in 4T connection within 5 ms  
**Comparator:** 9 bin output to Handler Interface  
**Interface:** Handler, GPIB and optional scanner interface

#### General Specifications

**Power Requirements:** 90 V to 132 V or 198 V to 264 Vac, 47 to 66 Hz, 100 VA max.  
**Operating Temperature/Humidity:** 0° C to 45° C, ≤95%RH @ 40° C  
**Size:** 100 mm H x 320 mm W x 450 mm D (3.94 in x 12.6 in x 17.72 in)  
**Weight:** Approximately 5 kg (11 lb)

#### Key Literature

4268A Capacitance Meter Product Overview, p/n 5967-5873E

### Ordering Information

4268A 120 Hz/1 kHz Capacitance Meter  
 Opt 001 Scanner Interface

#### Accessories Available

- 16044A 4-Terminal Test Fixture for Chip Components
- 16034E Chip Component Test Fixture
- 16334A Tweezer-Type Test Fixture
- 16048A Test Leads, BNC(1m)
- 16048B Test Leads, SMC(1m)
- 16048D Test Leads, BNC(2m)

- Low and selectable test signal current: 1  $\mu$ A to 10 mA
- Wide measurement range: 10  $\mu\Omega$  to 100 k $\Omega$
- 10  $\mu\Omega$  resolution
- Contact check function
- 1 kHz ac measurement
- High-speed measurement: 34 ms
- Built-in comparator
- Auto-measurement mode



4338B

### 4338B Milliohmmeter



The 4338B milliohmmeter is a precise, reliable, high-speed test tool for measurements of low resistance.

#### Precise, Low-Resistance Measurement

Contact failure of electromechanical components in a low-current circuit is a key issue for component reliability. The 4338B offers selectable low ac test signals (1  $\mu$ A to 10 mA). Users can now characterize low resistances of electromechanical components under low-current conditions. A high resolution of 10  $\mu\Omega$  allows you to determine the slightest differences in contact resistance testing of relays, switches, connectors, PC board traces and cables. The 1 kHz test signal eliminates potential errors introduced by thermoelectric effects on the device-under-test (DUT) contacts. The 1 kHz ac test signal is the best solution to evaluate the internal resistance of batteries, because it avoids dc energy consumption.

#### High-Speed Measurements

The high-speed (34 ms), built-in comparator and GPIB/handler interfaces make it possible to construct a measurement system using an automatic handler and external computer to minimize production test time.

#### Auto-Measurement Mode

When performing gross continuity testing where the test signal level is not a significant factor in the test, the auto-measurement function allows the instrument to select an appropriate test signal and measurement range setting.

#### Specifications

(Refer to Product Overview for complete specifications.)

##### Measurement Function

**Measurement Parameters:** R (ac resistance), X (reactance), L (inductance), Z (impedance),  $\theta$  (phase [°])

**Combinations:** R, R-X, R-L, Z,  $-\theta$  (series mode only)

**Mathematical Functions:** Deviation and percent deviation

**Display Digits:** 3, 4, or 5 (selectable)

##### Test Signal Characteristics

**Test Frequency:** 1 kHz

**Frequency Accuracy:**  $\pm 0.1\%$

**Test Signal Level:** 1  $\mu$ A, 10  $\mu$ A, 100  $\mu$ A, 1 mA, 10 mA rms

**Level Accuracy:**  $\pm (10\% + 0.2 \mu\text{A})$

**Maximum Voltage Across Sample:** 20 mV peak in any case

##### Measurement Range

Parameter	Measurement range
R	10 $\mu\Omega$ to 100 k $\Omega$
X,  Z	10 $\mu\Omega$ to 100 k $\Omega$ (typical)
L	10 nH to 10 H (typical)
$\theta$	-180° to +180° (typical)

**Measurement Accuracy:**  $\pm 0.4\%$  Basic for R

**Measurement Time:** Time interval from a trigger command to the end of measurement (EOM) signal output at the handler interface port

Mode	Time (typical)
SHORT	34 ms
MEDIUM	70 ms
LONG	900 ms

##### Correction Function

**Zero SHORT:** Eliminates measurement errors due to parasitic impedances in the test fixture

##### Comparator Function

HIGH/IN/LOW for each primary measurement parameter and the secondary measurement parameter

##### Contact Check Function

Contact failure between the test fixture and device can be detected

##### Other Functions

**Superimposed dc:**  $\pm 42$  Vdc maximum may be present on measurement terminals.

**Save/Recall:** Ten instrument setups can be saved/recalled from the internal nonvolatile memory.

**Continuous Memory Capability:** If the instrument is turned off, or if a power failure occurs, instrument settings are automatically memorized ( $\leq 72$  hours at 23° C  $\pm 5^\circ$  C).

**GPIB Interface:** All control settings, measured values, and comparator information

**Handler Interface:** All output signals are negative-logic, optically isolated open collectors.

**Output Signals Include:** HIGH/IN/LOW, index, end of measurement, and alarm. Input signals are keylock and external trigger.

#### General Specifications

**Power Requirements:** 90 V to 132 V or 198 V to 264 V, 47 Hz to 66 Hz, 45 VA max.

**Operating Temperature:** 0° C to 45° C

**Size:** 100 mm H x 320 mm W x 300 mm D (3.94 in x 12.6 in x 11.81 in)

**Weight:** 4.5 kg (9.9 lb)

#### Furnished Accessories

Operation manual, power cable (mating cable and test leads, or 16338A test lead set, must be ordered separately)

#### Key Literature

4338B Milliohmmeter Product Overview, p/n 5964-6183E

#### Ordering Information

**16338A** Test Lead Set

**16143B**<sup>1</sup> Mating Cable (0.6 m)

**16005B**<sup>2</sup> Kelvin Clip Lead (0.4 m, with large clip)

**16005C**<sup>3</sup> Kelvin IC Clip Lead (0.4 m, with red IC clip)

**16044A** SMD Kelvin Contact Test Fixture

**16006A**<sup>4</sup> Pin-Type Probe Lead (0.4 m)

**16007A**<sup>5</sup> Alligator Clip Leads (0.4 m, with 2 red clips)

**16007B**<sup>5</sup> Alligator Clip Leads (0.4 m, with 2 black clips)

**16005D**<sup>3</sup> Kelvin IC Clip Lead (0.4 m, with black IC clip)

**16064B** LED Display/Trigger Box

**4338B** Milliohmmeter

**Opt ABA** US-English Localization

**Opt ABJ** Japan-Japanese Localization

**Opt OBO** Delete Operation Manual

**Opt W30** Extended Repair Service

<sup>1</sup> Needed when using 16005B/C/D, 16006A and 16007A/B

<sup>2</sup> Need one pair of 16005B for measurement

<sup>3</sup> Use with 16005C(\*1ea) and 16005D(\*1ea)

<sup>4</sup> Need one pair of 16006A for measurement

<sup>5</sup> Use with 16007A(\*1ea) and 16007B(\*1ea)

4339B

- Wide measurement range:  $1 \times 10^3 \Omega$  to  $1.6 \times 10^{16} \Omega$
- Stable test fixtures: resistivity cell, component test fixture
- High-speed measurement: 10 ms
- Test sequence programming
- Resistivity calculations
- Grounded DUT measurement



4339B

### 4339B High-Resistance Meter



The 4339B high-resistance meter is Agilent Technologies' most advanced tool for making precision high-resistance measurements.

#### Precise and Stable Measurement

The measurement range is from  $1 \times 10^3 \Omega$  to  $1.6 \times 10^{16} \Omega$ , with a basic accuracy of 0.6%. This wide range allows accurate, high-resistance measurement of capacitors, relays, switches, connectors, materials, cables, and PC boards. The grounded device-under-test (DUT) measurement capability of the 4339B gives you the ability to evaluate cables and transformers under grounded conditions. The 16008B resistivity cell and the 16339A component test fixture are designed for stable and safe measurements of materials or components.

#### Simple Operation

The test-sequence program function allows you to control a series of resistance measurements in a sequence (charge-measure-discharge). You can set the charge time, measurement interval time, and number of measurements in a sequence through the front panel. The remaining time can be displayed when executing the sequence measurements. Surface resistivity ( $\rho_s$ ) and volume resistivity ( $\rho_v$ ) functions can be called to act upon measurement data. Calculated results are then automatically displayed, saving you time and effort.

#### High-Test Throughput

The 10 ms measurement time, 2 ms high-speed contact check function, built-in comparator, and GPIB/handler interfaces deliver high-speed test throughput for production environments.

#### 4339B Specifications

(Refer to Product Overview for complete specifications.)

**Measurement Parameters:** R (dc resistance), I (dc current),  $\rho_s$  (surface resistivity),  $\rho_v$  (volume resistivity)

**Mathematical Functions:** Deviation and percent deviation

**Display Digits:** 3, 4, or 5 (selectable)

**Test Voltage:** 0.1 Vdc to 1000 Vdc, 0.1 V steps @ 0.1 V to 200 V, 1 V steps @ 200 V to 1000 V

**Voltage Accuracy:** (0.16% + 100 mV) @  $\leq 200$  V, (0.16% + 500 mV) @  $> 200$  V

**Maximum Current:** 10 mA @  $\leq 100$  V, 5 mA @  $\leq 250$  V, 2 mA @  $\leq 500$  V, 1 mA @  $\leq 1$  kV

**Current Compliance Setting:** 0.5 mA, 1 mA, 2 mA, 5 mA, 10 mA

**Output Resistance:** 1 k $\Omega$   $\pm$  10%

**Input Resistance:** 1 k $\Omega$   $\pm$  10%

**Test Cable Lengths:** 2 m maximum

#### Measurement Range/Accuracy

Parameter	Measurement range	Basic accuracy
I	60 fA to 100 $\mu$ A	$\pm$ 0.4%
R ( $\Omega$ )	$1 \times 10^3 \Omega$ to $1.6 \times 10^{16}$	$\pm$ 0.6%

**Measurement Time:** Time interval from a trigger command to the end of measurement (EOM) signal output at the handler interface port (range: hold, display, off)

Mode	Time (typical)
SHORT	10 ms
MEDIUM	30 ms
LONG	390 ms

#### Correction Function

**Zero OPEN:** Eliminates measurement errors due to stray parasitic resistance in the test fixtures

**Test Sequence Program:** Controls a series of resistance measurements. Charge time, measurement interval time, and measurement number can be programmed.

**Comparator Function:** HIGH/IN/LOW for the measurement parameter  
**Contact Check Function**

Contact failure between the test fixture and device can be detected

**Available DUT Type:** Capacitive DUTs only

**DUT Capacitance:**  $\geq 1$  pF + 5% of residual stray capacitance

**Residual Stray Capacitance of the Fixture:**  $\leq 50$  pF

**Additional Measurement Time for Contact Check:** 2 ms

#### Other Functions

**Save/Recall:** Ten instrument setups can be saved/recalled from the internal nonvolatile memory

**Continuous Memory Capability:** If the instrument is turned off, or if a power failure occurs, instrument settings are automatically memorized ( $\leq 72$  hours at  $23^\circ\text{C} \pm 5^\circ\text{C}$ )

**GPIB Interface:** All control settings, measured values, and comparator information

**Handler Interface:** All output signals are negative-logic, optically isolated open collectors. Output signals include: HIGH/IN/LOW, no contact, index, end of measurement, and alarm. Input signals include: high voltage off, keylock, and external trigger.

#### General Specifications

**Power Requirements:** 90 V to 132 V or 198 V to 264 V, 47 Hz to 66 Hz, 45 VA max.

**Operating Temperature:**  $0^\circ\text{C}$  to  $45^\circ\text{C}$

**Size:** 100 mm H x 320 mm W x 450 mm D (3.94 in x 12.6 in x 17.72 in)

**Weight:** 6.5 kg (14.3 lb)

Complies with 73/23/EEC and 92/68/EEC safety standard EN61010-1

#### Furnished Accessories

Operation manual, shunt connector, power cable (Test fixtures and/or test leads must be ordered separately.)

#### Key Literature

4339B/4349B High Resistance Meters Product Overview, p/n 5964-6182E

Insulation Resistance Measurement of Plate Type Materials,

p/n 5968-3400E

Insulation Resistance Measurements of Electro-mechanical Components,

p/n 5968-0325E

#### Ordering Information

**4339B** High-Resistance Meter

**Opt ABA** US-English Localization

**Opt ABJ** Japan-Japanese Localization

**Opt OBO** Delete Operation Manual

**Opt W30** Extended Repair Service

**16339A** Component Test Fixture

**16008B** Resistivity Cell (50 mm Diameter Electrode)

**Opt 001** Add 26/76 mm Diameter Electrodes

**Opt 002** Add 26 mm Diameter Electrode

**Opt 003** Add 76 mm Diameter Electrode

**16117B** Low-Noise Test Leads (1 m, 2 clips)

**Opt 001** Add Pin Probes

**Opt 002** Add Soldering Sockets

**Opt 009** Delete Alligator Clips

**16117C** Low-Noise Test Leads (1 m, connectors)

**16118A** Tweezer Test Fixture

**16064B** LED Display/Trigger Box



**Impedance Measuring Instruments**

- 4291B 1.8 GHz Impedance/Material Analyzer Product Overview  
[5966-1501E](#)
- 4291B 1.8 GHz Impedance/Material Analyzer Technical Specifications  
[5966-1543E](#)
- 4192A LF Impedance Analyzer Data Sheet  
[5952-8896](#)
- 4294A Precision Impedance Analyzer 40 Hz to 110 MHz, Overview  
[5968-3808E](#)
- Accessories Selection Guide for Impedance Measurements Configuration Guide  
[5965-4792E](#)
- (PN 16451B-1) Dielectric Constant Measurements Using the 16451B Test Fixture  
[5962-9522E](#)
- (PN 4291-1) New Technologies for Wide Impedance Range Measurements to 1.8 Ghz  
[5966-2046E](#)
- (PN 4291-2) Evaluating Temperature Characteristics Using a Temperature Chamber and the 4291B  
[5966-1927E](#)
- On-Chip Semiconductor Device Impedance Measurement Using the 4291B (AN1300-7)  
[5966-1845E](#)

**Materials Test Equipment**

- 4291B 1.8 GHz Impedance/Material Analyzer Product Overview  
[5966-1501E](#)
- 4291B 1.8 GHz Impedance/Material Analyzer Technical Specifications  
[5966-1543E](#)
- 85070C High-Temperature Dielectric Probe Kit  
[5968-5330E](#)
- 85071C Materials Measurement Software Technical Data  
[5968-5331E](#)
- 16200A DC Bias Adapter Product Overview  
[5964-6700E](#)
- 16451B Dielectric Test Fixture Data Sheet  
[5962-9522E](#)
- 16452A Liquid Test Fixture Product Overview  
[5091-9228E](#)
- (PN 4291B) Impedance Measurements Using the 4291B and the Cascade Microtech Prober  
[5966-1928E](#)
- (PN 4291A-5) Dielectric constant Evaluation of Rough Surface Materials  
[5966-1926E](#)
- Solutions for Measuring Permittivity and Permeability  
[5965-9430E](#)

**LCR & Resistance Meters**

- LCR Meter Family Brochure  
[5963-5391E](#)
- LCR Meters, Impedance Analyzers and Test Fixtures Selection Guide  
[5952-1430E](#)
- 4268A Specification Sheet  
[5968-3970E](#)
- 4278A Capacitance Meter Data Sheet  
[5952-7882](#)
- 4287A Product Overview  
[5968-5443E](#)
- 4338B Milliohm Meter Data Sheet  
[5964-6183E](#)
- 4339B/4349B High Resistance Meters  
[5964-6182E](#)
- 4284A Technical Data  
[5963-5390E](#)
- 4285A Technical Data  
[5963-5395E](#)
- 4263B LCR Meter Product Overview  
[5964-6181E](#)

## Agilent's web site: Get news, updated product and support information, and more, 24 hours a day.

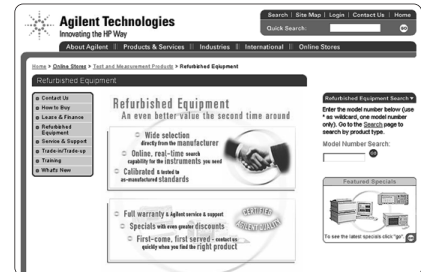
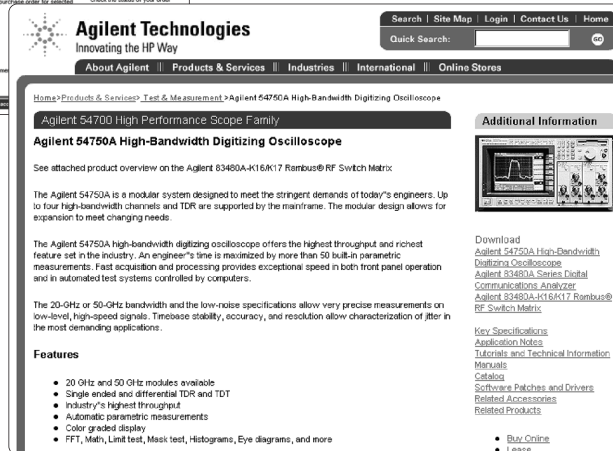

### Resources Available Online

- Product and support information more easily with helpful navigation aids and improved web pages that make it easier to access application notes, product overviews, technical details, frequently asked questions, manuals, software, news releases, education course descriptions and schedules, and much more.

- Updated comparison data and evaluation guides/tools that facilitate product selections
- Helpful application notes, downloadable interactive application notes, tutorials, online models, and other learning and problem-solving material
- Quick access to customer support services
- Information on recommended replacements for discontinued products
- Information in your local language\*
- The latest information on the status of your Agilent test and measurement order

### Take Action

- Selected Agilent products—including scopes, logic analyzers, EDA software, multimeters, data acquisition products, signal sources, counters, power supplies, and more\*
- Refurbished instruments\*
- Accessories\*
- Replacement parts\*

For more information on the test and measurement features, resources, and services available on Agilent's web site, see page 3.

Use our online test and measurement resources and services often!  
[www.agilent.com/find/tmc](http://www.agilent.com/find/tmc)

\*Availability of this feature may be limited; an expansion program is ongoing. Online purchases require a credit card.

For best results, view the Agilent web site with Microsoft's Internet Explorer browser.

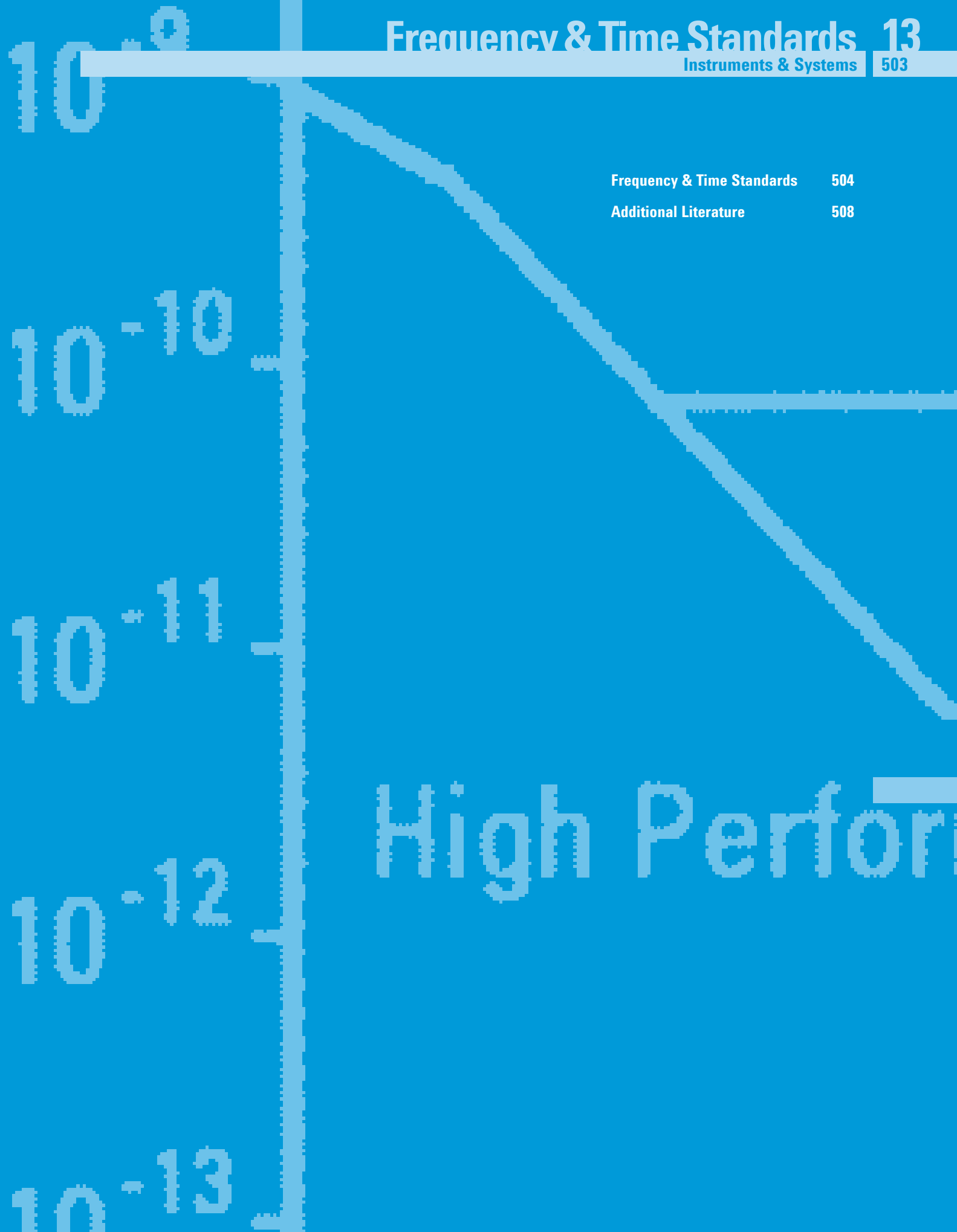

Frequency & Time Standards	504
Additional Literature	508

High Performance

## Agilent Keeps the World's Time

Agilent's industry-leading cesium primary frequency standards set and keep the world's time and frequency at national timekeeping bureaus and standards labs around the globe. Agilent cesium clocks, which provide more than 80 percent of the weighting of Universal Coordinated Time (UTC), virtually define the world's standard of the second, and the stability of the atomic second.

For decades, Agilent has led the industry, not only with the world's most stable cesium standards, but also with quartz and counter/modulation domain analyzer (MDA) technology.

Agilent's counters provide 20 picoseconds of resolutions per single shot time-interval measurement and MDAs provide 50 picoseconds of time-interval resolution. MDA technology—developed by Agilent—allows users to view signal dynamics without fear of missing events by making continuous, back-to-back measurements.

### Timing/Frequency Sources

Different levels of precise time and frequency are provided by sources ranging from GPS and cesium clocks to Rubidium and quartz clocks.

**Cesium:** Generally, the more expensive the frequency source, the better its accuracy and stability. Cesium-based oscillators for example, maintain accurate frequency indefinitely without the need for calibration. Because of this, cesium oscillators are applied to the most critical applications as primary reference clocks at the top of a network's hierarchy. By using cesium-based oscillators, networks and labs gain independence from other potentially less-reliable timing references. Agilent's extremely stable and accurate cesium based clock is the model 5071A Primary Frequency Standard.

**Rubidium:** Rubidium-based oscillators are lower cost than cesium and have excellent short-term stability (ability to consistently produce accurate time and frequency), but require frequent access to a primary reference signal to maintain calibration.

**Quartz:** High-quality quartz oscillators are extremely reliable, inexpensive and have excellent short-term stability. However the effects of aging and temperature on signal stability have made quartz oscillators less accurate over time than either cesium or rubidium. Agilent's highly reliable quartz oscillator module is the model 10811D/E.

### Oscillator Continuum

	Cesium	Rubidium	Quartz	Quartz w/GPS
<b>Long-Term Accuracy</b>	$\pm 7 \times 10^{-12}$ for life of cs. beam tube	$\pm 3 \times 10^{-11}$ /mo.	$\pm 5 \times 10^{-10}$ /day	$< 1 \times 10^{-12}$ /day avg. when locked to GPS
<b>Long-Term Aging</b>	N/A	$1 \times 10^{-12}$ /day	$1 \times 10^{-10}$ /day	N/A
<b>Oscillator Reliability (MTBF)*</b>	120,000–150,000 hrs.	50,000–150,000 hrs.	>500,000 hrs.	>500,000 hrs.

\*Mean time between failures

### Standards Labs

Agilent frequency standards and clocks provide accurate frequency, time interval and timekeeping capabilities to compare against national standards in timekeeping, R&D, and standards labs.

Agilent's Cesium-beam frequency standards are used in labs where the goal is a very high-accuracy primary frequency standard. Agilent quartz oscillators are used in virtually every frequency-control application, including atomic standards. The excellent short-term stability and spectral purity of the quartz oscillators contributes to the high quality of the output signal. For less demanding applications where some long-term drift can be tolerated, quartz oscillators are used as independent frequency sources.

Agilent's own standards lab in Santa Clara, California maintains an ensemble of three high-performance Agilent cesium-beam standards. The ensemble enhances its intrinsic accuracy through GPS links to both the US Naval Observatory (USNO) and the US National Institute of Standards and Technology (NIST).

On the following pages you will find the 5071A Primary Frequency Standard—Agilent's world clock, and the high-output 5087A Distribution Amplifier.



- Accuracy:  $\pm 5 \times 10^{-13}$
- Settability:  $\pm 1.0 \times 10^{-9}$
- "Flicker floor":  $\leq 5.0 \times 10^{-15}$  typical
- Fast warmup
- No adjustments before or during operation
- Remote operation



5071A

### 5071A Primary Frequency Standard

The Agilent 5071A primary frequency standard delivers unsurpassed accuracy and stability for both laboratory and field applications. Its improved cesium-beam tube reduces the effects of Ramsey pulling. New beam optics use cesium more efficiently. The combined results—increased accuracy and stability, and increased tube life—ensure a lower cost of ownership.

Because of its sophisticated programming and microprocessor control, the 5071A is extremely easy to use. Startup is simple and requires no adjustments. A logical menu structure simplifies front-panel operations, selections, and status reporting.

The 5071A can be operated and maintained anywhere. All controls are remotely programmable, status can be checked remotely, and no adjustments or alignments are necessary during operation. An internal battery provides 45 minutes of backup in case of ac power failure.

### Unmatched Accuracy and Stability

The 5071A uses Cesium II technology to double the accuracy of its predecessor, the 5061B. Cesium II technology includes a new cesium tube and redesigned microprocessor controlled electronics. The improved accuracy ensures that any 5071A Option 001 can power up to within  $5 \times 10^{-13}$  of the accepted standard for frequency. This is achieved under full environmental conditions typically in 30 minutes or less.

Cesium II technology brings a new level of stability to the cesium clock. The 5071A is the first cesium standard to specify its stability for averaging times longer than a day. It is the first standard to specify a "flicker floor" — the point at which the standard's stability does not change with longer averaging. The standard 5071A has a flicker floor better than 5 parts in  $10^{14}$ .

The Hewlett-Packard Co. started producing cesium-based frequency sources in 1964. These products are now produced by Agilent Technologies, which was formed from the Hewlett-Packard Test and Measurement Group. The exceptional accuracy and stability of the 5071A are a result of this long experience and are characterized by improved reliability, significantly greater stability, and exceptional accuracy. Backing up the reliability is a ten-year warranty on the standard cesium tube and a three-year warranty for the optional high-performance tube.

### Ease of Use

Startup and operation of the 5071A are extremely simple. Once connected to an ac or dc power source, the instrument automatically powers up to its full accuracy specifications. No adjustments or alignments are necessary during power-up or at any time during the lifetime of the cesium tube.

Intuitive menus logically report status and facilitate control of the instrument. These menus—Instrument State, Clock Control, Instrument Configuration, Event Log, Frequency Offset, and Utilities—are accessible via the front-panel LCD display and keypad.

### High-Performance Tube: Option 001

For the most demanding operations, the 5071A Option 001 high-performance cesium-beam tube offers increased performance. Accuracy is two times better than the standard tube, and stability is superior as well. The high-performance tube allows a flicker floor of better than  $1 \times 10^{-14}$ , and recent measurements at NIST show the flicker floor is typically as low as  $5 \times 10^{-15}$ .

### Telecommunications Options

The 5071A primary frequency standard may be optionally equipped to provide output frequencies, impedances, and signal formats required of a Primary Reference Clock in modern telecommunication networks. Configurations are available for both DS1 and CEPT standards. The 5071A can also be equipped to operate from a 48 Vdc central office battery.

Clock rates of 1.544 and 2.048 Mb/s are available. Impedance choices and signaling formats for all current ITU-T specifications are available. The 5071A with 2.048 Mb/s options are ITU-T G.811 compliant. All features found in a standard 5071A are retained when a 1.544 or 2.048 Mb/s option is installed. This includes both programmable 5/10 MHz outputs and the 1 MHz and 100 kHz outputs. The 1 PPS output and sync are only available on the front panel of the instrument.

The 5071A Option 048 equips the frequency standard to operate from 48 Vdc power. Two independent 48-volt power sources may be supplied. The power sources must be of the same polarity but either polarity may be used. The frequency standard draws power from the source with the higher voltage. Upon a source failure, the frequency standard will automatically switch to the other source—ensuring uninterrupted operation. The 5071A Option 048 automatically uses power from a 48 Vdc source if one is present. The instrument will use ac power if the dc source fails or no dc source is available. The internal battery normally supplied with the 5071A is not available when Option 048 is installed.

### Specifications

#### Accuracy and Stability

##### Full Environmental Range

Conditions (any combination of):

Temperature: 0° to 50° C

Humidity: 0 to 80% (40° C maximum)

DC Magnetic Field: 0 to 2 gauss

Warmup Time (typical):

15 minutes to normal operating status

30 minutes to full specs

##### Stability

Resolution:  $6.3 \times 10^{-15}$

Range:  $\pm 1.0 \times 10^{-9}$

Frequency Change Due to Environment:  $\pm 1 \times 10^{-13}$  ( $\pm 8 \times 10^{-14}$  Option 001)

Accuracy:  $\pm 1 \times 10^{-12} \pm 5 \times 10^{-13}$  (Option 001)

##### Flicker Floor:

$\leq 5.0 \times 10^{-14}$  ( $\leq 1.5 \times 10^{-14}$  typical)

$\leq 1.0 \times 10^{-14}$  (Option 001  $\leq 5.0 \times 10^{-15}$  typical)

Reproducibility:  $\leq 5.0 \times 10^{-13}$

#### Frequency Stability (5/10-MHz Outputs)

##### Time Domain Stability (Allan Deviation)

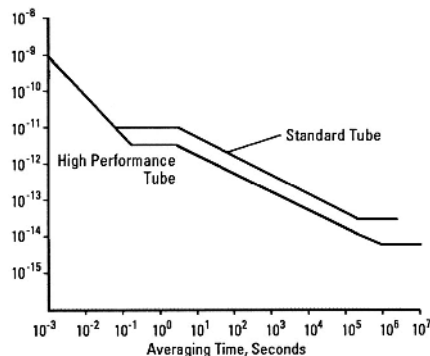

Averaging time (seconds)	$\sigma\gamma(2, \tau)$	
	Standard cesium-beam tube	High-performance cesium-beam tube (Option 001)
$10^{-2}$	$\leq 7.5 \times 10^{-11}$	$\leq 7.5 \times 10^{-11}$
$10^{-1}$	$\leq 1.2 \times 10^{-11}$	$\leq 1.2 \times 10^{-11}$
$10^0$	$\leq 1.2 \times 10^{-11}$	$\leq 5.0 \times 10^{-12}$
$10^1$	$\leq 8.5 \times 10^{-12}$	$\leq 3.5 \times 10^{-12}$
$10^2$	$\leq 2.7 \times 10^{-12}$	$\leq 8.5 \times 10^{-13}$
$10^3$	$\leq 8.5 \times 10^{-13}$	$\leq 2.7 \times 10^{-13}$
$10^4$	$\leq 2.7 \times 10^{-13}$	$\leq 8.5 \times 10^{-14}$
$10^5$	$\leq 8.5 \times 10^{-14}$	$\leq 2.7 \times 10^{-14}$
5 days	$\leq 5.0 \times 10^{-14}$	$\leq 1.0 \times 10^{-14}$

**Frequency Domain Stability**

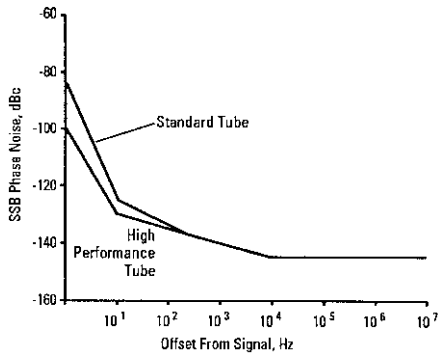

Offset from signal	SSB Phase Noise dBc	
	Standard cesium-beam tube	High-performance cesium-beam tube (Option 001)
$10^0$	$\leq -85$	$\leq -100$
$10^1$	$\leq -125$	$\leq -130$
$10^2$	$\leq -135$	$\leq -135$
$10^3$	$\leq -140$	$\leq -140$
$10^4$	$\leq -145$	$\leq -145$
$10^5$	$\leq -145$	$\leq -145$

**Sinusoidal Output Characteristics (all located on rear panel)**

Parameter	Ports 1 and 2 <sup>2</sup>	1 MHz, 100 kHz
Amplitude into 50 Ω load	>1 V rms	>1 V rms
Isolation between ports	>110 dB (typ.)	not specified
Harmonic and sub-harmonic signals (typical)	< -40 dBc	< -40 dBc
Non-harmonic distortion	< -80 dBc	not specified
Connector type	N	BNC
Source impedance (nominal)	50 Ω	50 Ω

<sup>2</sup>Each output can be set to either 5 or 10 MHz from the front panel or by remote command.

**Internal Standby Battery (nominal values)**

**Capacity:** 45 minutes at 25° C from full charge  
**Charge Time:** 16 hour maximum from fully discharged state  
**Charge Source:** AC input power only

**Remote System Interface and Control**

**RS-232-C** (DTE configuration): Complete remote control and interrogation of all instrument functions and parameters

**Interface Circuits:** Optically isolated

**Software Command Set:** SCPI, version 1990.0

**Connector:** 9-pin male rectangular D subminiature type

**Status Output:** Logic output for externally monitoring normal and abnormal operation (user-defined)

**Output:** TTL open collector with internal pull-up resistor

**Circuit Sink Capability:** Up to 10 mA

**Connector:** BNC on rear panel

**Environmental and Physical**

**Temperature**

**Operating:** 0° C to 55° C

**Non-operating:** -40° C to +70° C

**Size:** 133.4 mm H x 425.5 mm W x 523.9 mm D (5.25 in x 16.75 in x 20.63 in)

**Weight:** 30 kg (65 lb)

**Ordering Information**

**5071A** Primary Frequency Standard

**Opt 001** High-Performance Cesium-Beam Tube

**Opt 0B2** Extra Operating and Programming Manuals

**Opt 0BW** Assembly-Level Service Manual

**Opt 908** Rack Flange Kit (for use without handles)

**Opt 913** Rack Flange Kit (for use with handles included with 5071A)

**Opt W30** Extended Repair Service (see page 581)

**Opt W50** Extended Repair Service (not available with Option 001)

**Telecommunications Options**

**Opt 048** 48 Vdc Power

**Opt 104 or 105** 1.544 Mb/s, 100 Ω Balanced

**Opt 220, 221 or 222** 2.048 Mb/s, 120 Ω Balanced

**Opt 270, 271 or 272** 2.048 Mb/s, 75 Ω

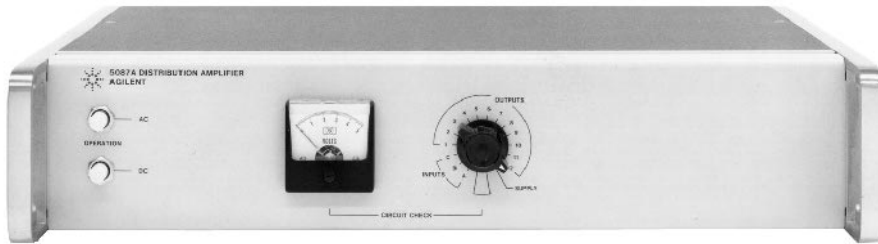

5087A

### 5087A Distribution Amplifier

The 5087A Distribution Amplifier provides the flexibility needed for distribution of standard frequency outputs, where either 5 or 10 MHz output frequencies are required. Its modular construction allows you to configure or upgrade the product for a variety of distribution needs.

Several standard configurations are available as well as special combinations of input and output modules. Amplifiers can be added or the configuration easily changed using 10812A options.

#### 5087A Specifications

**Inputs:** Up to three, rear-panel BNC

**Frequencies:** 5 MHz or 10 MHz

**Input Level:** 0.3 to 3.0 V rms into 50  $\Omega$

**Outputs:** Up to 12, rear-panel BNC

**Frequencies:** 10 MHz or 5 MHz

**Levels:** 0 to 3 V into 5  $\Omega$  (screwdriver adjustment)

**Harmonic distortion:** >40 dB below rated output

**Non-Harmonic Distortion:**

5 MHz: >80 dB below rated output

10 MHz: >70 dB below rated output

**Isolation**

**Load:** (open or short on any other channel)

**Amplitude Change:** 0.1%

**Phase Change:** < 0.1 ns at 5 or 10 MHz

**Injected Signal:** 1 V rms signal up to 50 MHz applied to 5 MHz output, will be down >60 dB in all other outputs; 10 MHz output channel will be down >50 dB.

**SSB Phase Noise\*** (5 MHz): >145 dB below signal in 1 Hz BW for frequencies >1 kHz from carrier

**Short-Term Stability Degradation\*** (5 MHz): <  $1 \times 10^{-12}$  (1-s average)

**Environmental**

**Temperature:** MIL-E-16400, class 4

**Operating:** 0° C to 50° C

**Storage:** -62° C to +75° C

**Stability**

**Amplitude:**  $\pm 0.5$  dB, 0° C to 50° C

**Phase:** < 0.1 ns/° C

**EMC:** MIL-STD-461A

**Humidity:** 95% at 40° C

**Altitude:** Up to 9 km or 30,000 feet

**General**

**Power:**  $\pm 115$  or 230 V  $\pm 10\%$ , 48 to 440 Hz, 20 VA maximum, or 22 to 30 Vdc, 600 mA maximum

**Size:** 88 mm H x 425 mm W x 286 mm D (3.5 in x 16.7 in. x 11.3 in)

**Weight:** Typical (Option 031), 7 kg; Shipping, 10 kg (22 lb)

\* Input signal must be at least as good as 5087A specifications for this performance.

#### Ordering Information

**5087A Distribution Amplifier Mainframe**

**Standard Configurations** (input and output amplifiers)

**Opt 032** Single 5 MHz Input and 12 Output

**Opt 033** Single 10 MHz Input and 12 Output

**Special Configurations** (Specify individual options and quantity)

**Input Preamplifiers** (up to 3 total)

**Opt 004** Input Preamplifier (5/10 MHz)

**Opt 011** 5-to-10 MHz Input Doubler

**Opt 013** 10-to-5 MHz Input Divider

**Output Amplifiers** (up to 12 total)

**Opt 001** 5 MHz Output Amplifier

**Opt 012** 10 MHz Output Amplifier

#### How to Order

When ordering, specify the 5087A mainframe and either one of the standard configurations (options 032 to 033) of preamplifiers and output amplifiers, or a special configuration. For a special configuration, specify the desired quantity (up to three) of input amplifier/divider/doubler and (up to 12) matching output amplifiers. Ordered units will be shipped completely configured and tested. Order should indicate number and frequency(s) of inputs and outputs.

**Accessories Available**

**Opt 908** Rack flange kit

**Opt 910** Extra manual

**Opt W30** 3 year return for repair service

**Opt W32** 3 year return for calibration service

**Opt W34** 3 year return for compliant cal service

**Opt W50** 5 year return for repair service

**Opt W52** 5 year return for calibration service

**Opt W54** 5 year return for compliant cal service

**General Purpose**

The Science of Timekeeping, Application

Note 1289

[5965-7984E](#)

5071A Brochure/Technical Specifications

[5968-1862E/EUS](#)

5071A Collection of Technical Papers: Architecture,  
Design Aspects, and Performance of a  
New Cesium Beam Frequency Standard

[5091-5873E](#)

5087A Distribution Amplifier

[5952-7575E](#)



**Digital Video Test Equipment** 510

**Regulatory Test Equipment** 513

*See also*

Electronic Counters 137

Signal Analyzers 227

**Maintenance Test Equipment** 515

**Broadcast TV Analyzers** 516

*See also*

Signal Analyzers 227

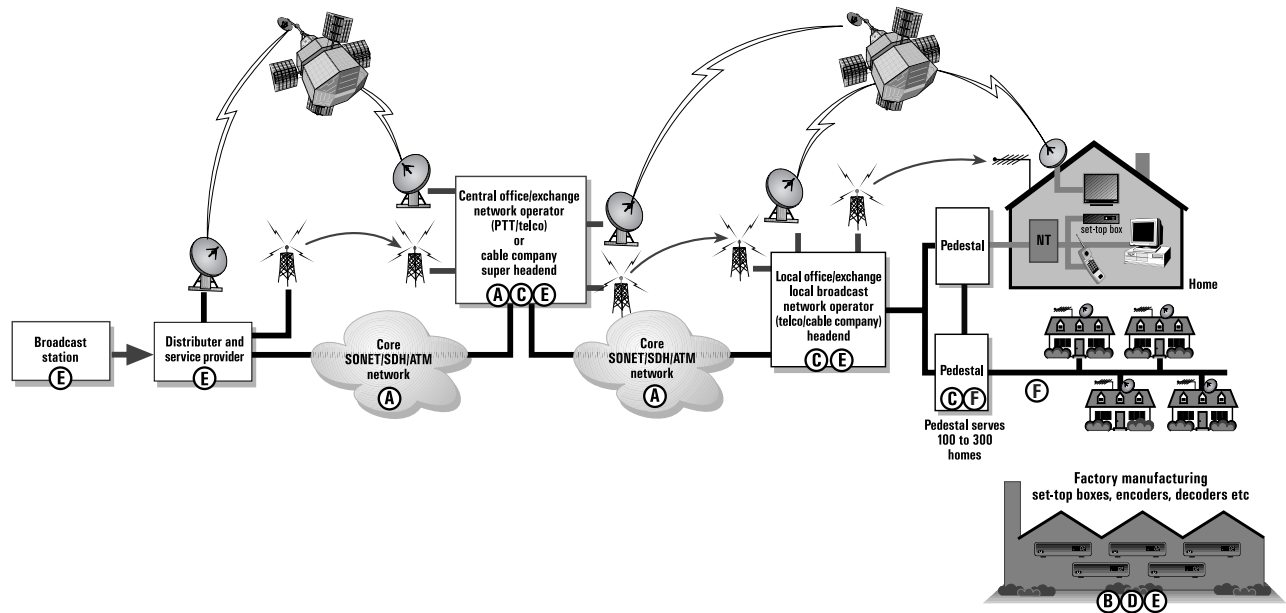

## Test Equipment for Digital Video Broadcast/Cable TV

Digital transmission is the key enabling technology that will allow cable systems to deliver a multitude of emerging services. Ensuring a high quality of service requires testing various aspects of the signal—data integrity, modulation, and RF signal quality. Agilent Technologies offers a wide range of instruments for testing all these aspects of digital video service development, deployment, and device manufacturing.

**A**  
**E6271A MPEGscope ATM**  
 Real-time MPEG-2 tests over AAL-5, MPEG-2 transport quality of service measurements, real-time PSI table decodes. Runs on E4200 Broadband Series Test System.

**B**  
**89400 Digital Video Signal Analyzer**  
 State-of-the-art modulation quality measurements for R&D and commissioning. See page 512.

**C**  
**85940 DVB-C QAM Analyzer**  
 Comprehensive RF, modulation, and data quality measurements for cable system operators. See page 511.

**D**  
**ESG-D4000B Digital Signal Generator**  
 Used to produce highly accurate IF or RF signals. See page 205.

**E2507B Multi-Format Communications Signal Simulator**  
 Simulate varying return link traffic levels with multiple-modulated signals. See page 199.

**E**  
**E6277A MPEGscope Plus**  
 Capture, analyze, and transmit transport streams, real-time transport stream analysis, bit error rate test, TS and PES protocol, DVB, and ATSC table decodes; optional ES compression analysis software.

**F**  
**CaLan 3010 R/H Sweep/Ingress Analyzer**  
 Digital channel power, sweep and ingress measurements for network technicians. See page 515.

### Key Literature

Digital Basics for Cable Television Systems, by Jeffrey L. Thomas and Francis M. Edgington. Prentice Hall 1998; ISBN 0-13-7439 15-6  
 1996 Digital Video Test Symposium, Attendee Handbook, p/n 5965-0964E

- Field testing solution for DVB-C<sup>1</sup> cable TV systems
- Test from the headend to the subscriber drop
- Comprehensive suite of RF, modulation, and data quality measurements
- Verify your quality of service



8594Q QAM Analyzer

### 8594Q QAM Analyzer

The 8594Q QAM Analyzer is a comprehensive solution for RF installation and maintenance testing of DVB-C (Digital Video Broadcast via Cable) signals on cable TV systems. It gives engineers the measurement capability required to accurately verify the quality of service delivered to the subscriber. All measurements are easy to access and the results are presented in clear graphical displays.

### Applications

- The 8594Q QAM Analyzer can help you during:
- Headend equipment installation and maintenance
  - System verification
  - Field installation and maintenance
  - Modulator manufacturing or incoming inspection test
  - Opt J91—Modulation measurements in 6 MHz channel bandwidths

### Measurement Capability

The 8594Q QAM Analyzer demodulates and accurately measures the 16, 64 or 256 QAM signals carried through the DVB-C system. It provides new measurement metrics necessary to characterize these signals and troubleshoot problems. The graphical displays, clear user interface, and one-button measurement capability will help make the transition easy for analog cable TV engineers.

To accurately verify your quality of service, the 8594Q QAM Analyzer provides the following measurement capability:

- Average channel power—To verify the signals levels from the headend through the system to the subscriber drop
- Adjacent channel power—To make sure that transmissions are not leaking into and causing interference in adjacent channels
- Constellation display—Display the constellation points and quickly identify any modulation problems
- Error vector magnitude and modulation error ratio—To quantify the modulation quality of the signal transmitted through the system
- Equalizer response—Frequency, impulse, group delay, and phase response plots can be displayed on screen to show distortions caused by the transmission channel
- Data measurements—Add Option 195 to the 8594Q QAM Analyzer to verify that the MPEG data has been correctly decoded from the DVB-C RF signal and check transport stream content. The option also proves a real-time output (both ASI and parallel), to allow access to the data stream for further analysis. The 8594Q option 195 includes a real-time FEC decoder. By monitoring the activity of the FEC decoder, analysis of byte and packet errors is provided.

The 8594Q QAM Analyzer makes all of these measurements quickly and accurately. In addition the 8594Q QAM Analyzer provides a fully featured 2.9 GHz spectrum analyzer.

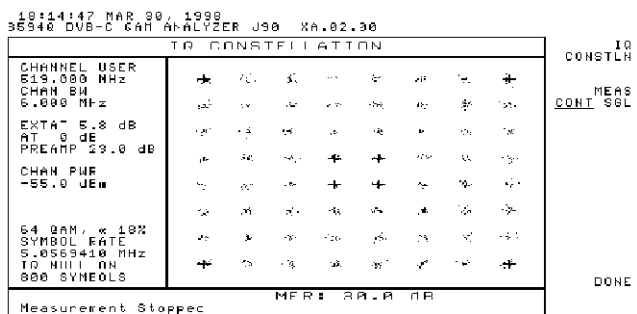
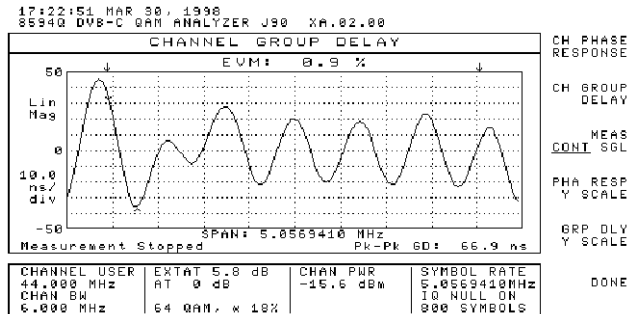

### Key Literature

- DVB-C Solutions, Product Overview, p/n 5965-5826E
- DVB-C Solutions, Product Note, p/n 5965-4991E

### Ordering Information

#### 8594Q QAM Analyzer

- Opt 190<sup>2</sup> DVB-C Measurement Capability
- Opt J91<sup>2</sup> Modified to operate at
- Opt J93<sup>2</sup> specific symbol rates in
- Opt J94<sup>2</sup> 6 MHz channel bandwidths<sup>4</sup>
- Opt 195<sup>3</sup> Data Measurements
- Opt 016 Soft Yellow Operating/Carrying Case
- Opt 040 Front Panel Protective Cover with Storage
- Opt 043 RS232/Parallel Interface
- Opt 908 Rackmount Kit without Handles
- Opt 909 Rackmount with Handles
- Opt 910 Additional Manual Set

<sup>1</sup> DVB-C is a standard defined by the European Telecommunications Standards Institute.  
<sup>2</sup> Opt 190, J91, J93, or J94 required.  
<sup>3</sup> Opt 195 measurements are specific to the DVB standard.  
<sup>4</sup> Contact sales office for details.

89441A  
89441V  
89400  
Option AYH

- Measure HDTV (ATSC) or DVB-T or ISDB-T systems
- Adaptive equalization now included in Option AYA
- Peak-to-average power measurements, including CCDF
- Constellation, eye, and error magnitude analysis for QAM, VSB, and other modulation formats (Option AYH)
- Dynamic power measurements, including: peak, average, band-integrated, and adjacent channel
- Waveform capture and analysis
- Carrier phase noise measurements to  $-124$  dBc/Hz (typical at 10 kHz offset)
- High input sensitivity for DTV field testing

### 89400 Option AYH Digital Video Signal Analyzer

Meeting the needs of both broadcasters and system designers, the 89441V and the 89400 series with option AYH or COFDM analysis software precisely characterize RF signals in the emerging modulation formats of the digital video industry, including COFDM, QAM and VSB. Off-the-shelf, lab-quality spectrum and waveform measurements allow designers of ATV/HDTV components, equipment and systems to deliver higher-quality video signals faster and for less cost than with custom-built test tools.

### Signal Quality Measurements

89400 Vector Signal Analyzers measure signal power and waveforms in the time, frequency, and modulation domains, making them extremely versatile design and troubleshooting tools. Their advanced DSP architecture provides measurements that are not only fast, but exceptionally accurate and informative—even for complex, broadband ATV signals.

For more information about 89400 signal analysis capabilities, see page 262.

### Digital-Modulation Analysis

The 89441V bundles option AYH with other necessary options for Digital Video Test in one product. Digital video analysis Option AYH equips 89400 analyzers to demodulate and characterize a wide variety of video-related signal formats. Results are shown via traditional eye and constellation displays, or as error vector magnitude and MER (Modulation Error Ratio) measurements. EVM quantifies the instantaneous difference between the actual input signal and an ideal, internally-generated reference signal containing the same data stream. It is a measurement technique now widely accepted among digital RF communications designers and international standards organizations. Expressed as a time waveform, an rms average, or an error spectrum, EVM is sensitive enough to reveal the slightest degradations in signal quality, such as those which occur between the input and output of even a single amplifier stage. Use it to troubleshoot BER or other signal problems back to their root causes.

In digital demodulation mode, carrier lock, and symbol clock synchronization are automatic. This means external carrier reference or clock inputs are never required, making the 89400 analyzers useful even in remote or field test applications.

### COFDM Modulation Analysis

For modulation measurements to the European DVB-T (Digital Video Broadcast—Terrestrial) standard, or ISDB-T in Japan, Agilent has developed software for use with the 89441A and a PC for external data analysis.

DVB-T uses a COFDM (Coded Orthogonal Frequency Division Multiplex) modulation scheme, with either a nominal 2000 (“2k”) or 8000 (“8k”) carriers contained within a standard 8MHz RF channel. Each carrier is modulated with low-rate 64QAM.

The analysis software is a pre-configured Agilent VEE application, and is supplied on CD-ROM. As well as making all the normal RF tests on the signal, the system makes the following DVB-T modulation measurements:

1. Symbol magnitude spectrum
2. Symbol phase spectrum
3. Symbol IQ constellation
4. EVM magnitude spectrum
5. EVM complex
6. Equalizer magnitude spectrum
7. Equalizer phase spectrum
8. Error statistics summary table

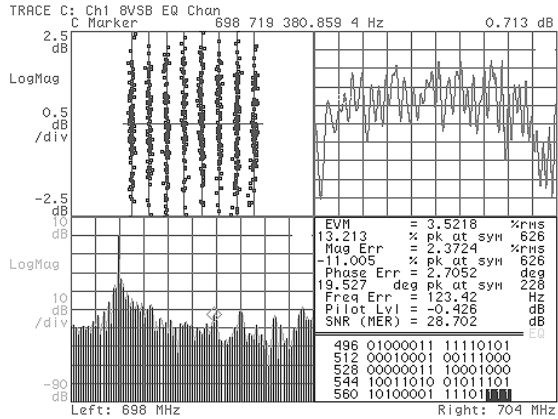

Measurement displays include channel frequency response and impulse response of the equalization filter.

9. Data power from nominal relative to pilots
10. TPS power from nominal relative to pilots
11. Modulation Error Ratio (MER)

### Adaptive Equalization

A new adaptive equalization capability is included and works with digital demodulation to remove linear errors, such as frequency response and reflections, from transmitted signals. Measurements more closely approximate the performance of real-world receivers and can be used to isolate linear vs. non-linear error mechanisms. Measurements include displays of channel frequency response and impulse response of the equalization filter. This equalization does not require prior knowledge of the signal such as a training sequence.

For more information, including downloading a free DTV field test IBASIC program, visit our web site: <http://www.agilent.com/find/89400>

### Specifications

#### Frequency Range and Bandwidth

Model number	Frequency range	Sensitivity	Maximum bandwidth
89410A	dc to 10 MHz	-144 dBm/Hz	10 MHz
89441A	dc to 2650 MHz	-160 dBm/Hz	8 MHz
89441V	dc to 2650 MHz	-160 dBm/Hz	8 MHz

#### Symbol Rates (Symbols/Sec)

VSB Formats: 10.77 M nominal (adjustable)

QAM Formats: Rate < (Analyzer BW)/(1 +  $\alpha$ )

#### Examples:

Model number	QAM $\alpha = 0.2$	DVB $\alpha = 0.15$
89410A	< 8.33 M	< 8.70 M
89441A	< 6.09 M	< 6.96 M
89441V	< 6.09 M	< 6.96 M

#### Maximum Measurement Size

1 sample/symbol: 4096 symbols

5 samples/symbol: 819 symbols

#### Modulation Formats

8, 16VSB

COFDM (using external PC analysis software E9285A Opt K01)

16, 32, 64, 256QAM

16, 32, 64QAM (DVB)

(QPSK, Offset QPSK, FSK, MSK, BPSK and other formats are supported by Option AYA—not available on 89441V)

#### Residual Error (instrument contributed)

QAM Formats: Symbol rate 5 to 7 MHz,  $0.15 < \alpha < 0.2$ , full-scale signal  $\geq -25$  dBm:  $\leq 1.0\%$  EVM typ. ( $\leq 40$  dB SNR)

VSB Formats: Symbol rate 10.762 MHz,  $\alpha = 0.1152$ , full-scale signal  $\geq -25$  dBm:  $\leq 1.5\%$  EVM typ. ( $\leq 36$  dB SNR)

#### Required Options for 89410A and 89441A

AYA (vector modulation analysis)

For complete product, literature, and ordering information, see page 262.



- Dedicated cable TV analyzer
- Portable and easy to use
- Non-interfering RF and video measurements
- Digital carrier power measurements
- Cable TV data management software



8591C

## 8591C Cable TV Analyzer

### Industry's Only Cable TV Analyzer That Keeps Pace with Changing Regulations

The 8591C cable TV analyzer (1 MHz to 1.8 GHz) is the first economical, portable, one-box solution for making automatic, non-interfering cable TV RF and video measurements. The analyzer features a flexible hardware and software architecture that can be upgraded easily to protect your investment as new test requirements are introduced.

Included in the cable TV analyzer are the features you need for cable TV testing compatible with worldwide formats and standards, including all FCC proof-of-performance tests:

- 85721A cable TV RF/video measurements personality to simplify channel and system cable TV measurements
- 75  $\Omega$  input matches analyzer to cable TV impedance
- Built-in, internally switched preamplifier for improved carrier-to-noise measurements
- Precision frequency reference to accurately measure carrier frequency
- Fast time-domain sweeps for displaying individual TV lines
- TV trigger for selecting TV lines by number
- RS-232 and parallel interfaces for PC and printer operation, respectively
- 85702A 128K RAM card for storing test data
- Rugged, yellow, soft carrying case

Options add even greater measurement capability to the analyzer. These include a 75  $\Omega$  tracking generator, narrow resolution bandwidths, and non-interfering RF and video measurements.

### Non-Interfering Measurements

Option 107 for the 8591C and the 8590 E-series spectrum analyzers adds the hardware needed to make non-interfering RF and video measurements. Non-interfering measurements let you perform required tests on multiple channels at multiple locations with no impact on customer programming. The video measurement capability allows you to perform required FCC color tests. Option 107 also enables simultaneous viewing of TV pictures and listening to program sound. The hardware demodulates NTSC-format television signals as well as versions of PAL and SECAM.

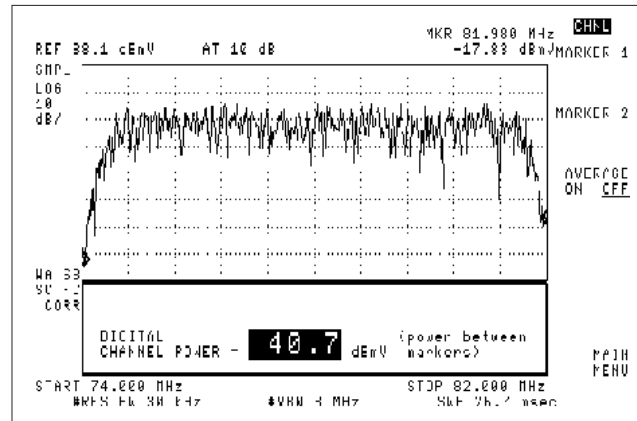

Digital Carrier Power Measurement on 8591C

### Measurements for RF and Video Testing

The 85721A measurement personality card (included with the 8591C) customizes the analyzer for easy, non-interfering proof-of-performance measurements on NTSC-, PAL-, or SECAM-format signals. This software adds dedicated cable TV test functions and measurements that you can perform with the push of single keys. Measurements include the following functions and tests:

- Automatic tuning of cable TV and TV broadcast carriers
- Visual and aural carrier levels and frequencies
- Digital carrier power
- System channel survey
- Depth of modulation
- TV aural and FM broadcast carrier deviation
- Carrier-to-noise ratio (C/N)
- In-channel frequency response
- Hum/low frequency disturbances
- System frequency response
- Baseband TV line and field viewing
- TV aural and FM broadcast carrier demodulation
- Distortion (CSO/CTB)
- Crossmodulation
- Ingress and co-channel viewing

System monitor capability automates measurements, allowing the analyzer to test without assistance from the operator. It also allows you to design test plans and to turn test data into reports instantly. With Option 107 added to the cable TV analyzer, non-interfering measurements of carrier-to-noise, in-channel frequency response and distortions can be made, as well as video measurements:

- Differential gain
- Differential phase
- Chrominance-luminance delay inequality

### Painless Reports and Data Archiving

Take the pain out of cable TV reports with the 85921B cable TV data management software. Running on IBM compatible PCs, it downloads test data from your 8591C<sup>1</sup>, and CaLan 2010B, 3010, 3010B, and 3010R into a PC database for making reports and archiving data. The software compares measurement results to your specifications and displays pass/fail messages for each test. Test data can also be exported to a word processor or spreadsheet for other analysis.

You can print the results of every test run at each specified location in the cable system. The printout will list all the channels tested, as well as additional required information such as the date of the testing, the name and qualifications of the person who ran the test, and the serial number of the equipment used. Add Option 032 to automatically generate reports in a format compliant with the FCC regulations. All RF and video tests (except leakage) currently required by the FCC are included.

<sup>1</sup> The 85921B accepts system mode-acquired data from the 85721A measurement personality for the NTSC format only. The 85721A is bundled in the 8591C and can be added to an 8590E series analyzer.

8591C  
85721A  
85905A  
85921B

8591C  
85721A  
85905A  
85921B

### Specification Summary

Specifications apply to the 8591C cable TV analyzer with preloaded 85721A measurements personality, and to the 8591E spectrum analyzer with Options 001, 004, and 301, and the 85721A personality.

### General

**Channel Selection:** Analyzer tunes to specified channels

**Input:** 75  $\Omega$ , BNC

**Frequency Range:** 5 to 1002 MHz for channel mode;

54 to 896 MHz for system mode;

1 MHz to 1.8 GHz for spectrum analyzer mode

**Amplitude Range:** -15 to +70 dBm V for S/N > 30 dB

**Displayed Average Noise Level** (1 kHz RBW, 0 dB atten.)

**Without Preamplifier:**  $\leq -63$  dBmV (1 to 1500 MHz)

**With Internal Preamplifier:**  $\leq -83$  dBmV (1 to 1000 MHz)

**With External Preamplifier:**  $\leq -83$  dBmV (1 to 1000 MHz)

### Cable TV Measurements

**Visual Carrier Frequency** (visual carrier frequency is counted)

**Precision Frequency Reference**

**Resolution:** 100 Hz

**Accuracy:**  $\pm(1.2 \times 10^{-7} \times \text{carrier freq.} + 110 \text{ Hz})$

**At 55.25 MHz** (ch. 2):  $\pm 117$  Hz

**At 325.25 MHz** (ch. 41):  $\pm 149$  Hz

**At 643.25 MHz** (ch. 94):  $\pm 187$  Hz

**Visual-to-Aural Carrier Frequency Difference** [counted frequency difference between visual (vision) and aural (sound) carriers]

**Difference Range:** 4.1 to 4.9 MHz

**Resolution:** 100 Hz

**Accuracy:**  $\pm 221$  Hz for precision frequency reference (std)

**Visual Carrier Peak Level** (measured to an absolute standard)

**Amplitude:** -15 to +70 dBm V

**Resolution:** 0.1 dB

**Absolute Accuracy:**  $\pm 2.0$  dB for S/N > 30 dB

**Relative Accuracy:**  $\pm 1.0$  dB relative to adjacent channels in frequency;  $\pm 1.5$  dB relative to all other channels

**Visual-to-Aural Carrier Level Difference** [measured difference between peak amplitudes of visual (vision) and aural (sound) carriers]

**Difference Range:** 0 to 25 dB

**Resolution:** 0.1 dB

**Accuracy:**  $\pm 0.75$  dB for S/N > 30 dB

**Digital Carrier Power**

**Accuracy (characteristic):**  $\pm 0.75$  dB

**Readout Resolution:** 0.1 dB

**Depth of Modulation, Characteristic** (percent difference from horizontal sync tip to max. video level)

**AM Range:** 50 to 93%

**Resolution:** 0.1%

**Accuracy:**  $\pm 2.0\%$  for C/N > 40 dB

**FM Deviation, Characteristic** (peak reading of FM deviation)

**Range:**  $\pm 100$  kHz

**Resolution:** 100 Hz

**Accuracy:**  $\pm 1.5$  kHz

**Hum/Low Frequency Disturbance** (measured for power-line frequency and low-frequency disturbance)

**AM range:** 0.5 to 10%

**Resolution:** 0.1%

**Accuracy:**  $\pm 0.7\%$  for hum  $\leq 5\%$

**Visual Carrier-to-Noise Ratio, C/N** (calculated from visual-carrier peak level; min. noise level normalized to 4 MHz for NTSC format)

**Range** (input level dependent): 63 dB max. for +25 dBmV input

**C/N Resolution:** 0.1 dB

**C/N Accuracy** (input level and measured C/N dependent):  $< \pm 1$  dB for 50 dB C/N and +25 dBmV input with external preselector filter

**Composite Second Order and Composite Triple Beat Distortion**

(CSO and CTB measured relative to visual-carrier peak)

**Range** (input level dependent): 77 dB max. for 25 dBm V input

**Resolution:** 0.1 dB

**Accuracy** (input-level, measured-CSO/CTB dependent):

$< \pm 1.5$  dB for 60 dB CSO/CTB and +25 dBm V input

**Crossmodulation Characteristic** (15.7 kHz horizontal-line related AM measured on unmodulated visual carrier)

**Range:** 60 dB, usable to 65 dB

**Resolution:** 0.1 dB

**Accuracy:**  $\pm 2.6$  dB for xmod < 50 dB, C/N > 40 dB

**System Frequency Response** (system amplitude variations measured relative to a reference trace stored during the setup)

**Frequency Response Setup:** Reference-trace storage for

50 traces including analyzer states

**Frequency Response Test:** Trace-flatness accuracy is  $\pm 0.1$  dB per dB deviation from a flat line and  $\pm 0.75$  dB maximum cumulative error

**Option 107 Operation** (for video and non-interfering measurements)

**TV Receiver Input**

**Frequency Range:** 50 to 850 MHz

**Amplitude Range:** 0 to 40 dBm V

**Non-interfering Color Test** (requires FCC composite or NTC-7 test signal for NTSC format)

**Differential Gain Accuracy:**  $\leq \pm 4\%$ <sup>1</sup>

**Differential Phase Accuracy:**  $\leq \pm 3^\circ$ <sup>1</sup>

**Chrominance-luminance Delay Inequality Accuracy:**  $\leq \pm 45$  ns,  $\pm 32$  ns typical

**Non-interfering Tests with Gate ON<sup>2</sup>**

**C/N and CSO:** Quiet line must be selected

**In-channel Frequency Response Accuracy:**  $< \pm 0.5$  dB within channel (requires sin x/x, Philips ghost canceling reference, or FCC/NTC-7 multiburst test signal for NTSC format)

### Preamplifiers

**85905A 75  $\Omega$  Preamplifier** (external)

**Frequency Range:** 45 to 1000 MHz

**Gain:** 20 dB  $\pm 1.0$  dB

**Noise Figure:** 7 dB maximum at midband

**8591C 75  $\Omega$  Preamplifier** (internal) (std)

**Frequency Range:** 1 to 1000 MHz

**Gain:**  $\geq 24$  dB

**Noise Figure:**  $\leq 10$  dB

### Ordering Information

**8591C** Cable TV Analyzer (includes 85721A)<sup>3</sup>

**Opt 107<sup>4</sup>** TV Receiver/Video Tester (includes 75  $\Omega$  coupler and cables)

**Opt 011** 75  $\Omega$  Tracking Generator

**Opt 015** Change Yellow to Tan Soft Carrying Case

**Opt 030** Cable TV Data Management Software with FCC Reports

**Opt 040** Front-Panel Cover (used without soft carrying case)

**Opt 041<sup>5</sup>** GPIB and Parallel<sup>6</sup> Interfaces

**Opt 119** Noise Figure Card

**Opt 130** Narrow Resolution Bandwidths

**Opt 180<sup>7</sup>** TV Picture Display

**Opt 701** Delete TV Trigger, AM/FM Demodulator, Fast Time-Domain Sweeps

**Opt 704** Delete Precision Frequency Reference

**Opt 908** Rackmount without Handles

**Opt 909** Rackmount with Handles

**Opt 915** Component Level Info. and Service Guide

**Opt W30** Two Additional Years Return-to-Agilent Service

**Opt W32** Two Additional Years Return-to-Agilent Calib.

**Opt R07** Retrofit Kit for Option 107

**Recommended Accessories**

**85702A** 128K RAM Card (Additional)

**85721A<sup>3</sup>** Cable TV Measurements and System Monitor Personality (for 8590 E-series)

**85901A** Portable AC Power Source

**85905A** 75  $\Omega$  Preamplifier

**85921B** Cable TV Data Management Software

**Opt 030** with FCC Reports

**24542U** RS-232 Nine-Pin Cable (analyzer to PC)

**24542G** RS-232 Nine-Pin to 25-Pin Cable (analyzer to PC)

**C2950A** Parallel Cable (analyzer to printer)

**10833A** GPIB Cable

<sup>1</sup> 20° C to 30° C,  $\geq 20$  dBm V input

<sup>2</sup> Gate ON synchronizes the measurement to the TV line selected

<sup>3</sup> NTSC format only; worldwide options available

<sup>4</sup> Not compatible with Option 180

<sup>5</sup> Replaces standard RS-232 and parallel interfaces

<sup>6</sup> Print and plot control only

<sup>7</sup> Not compatible with Option 107

- Ingress detection
- Exclusive DigiSweep technology
- Built-in digital carrier power measurement
- TDMA and Bursted Power
- Built-in reverse sweep transmitter covers 5 to 1000 MHz
- Headend unit supports up to ten field units
- Rugged and easy to use
- Compatible with Cheetah Technologies



The CaLan 3010R and 3010H Sweep/Ingress Analyzer



CaLan 2010  
CaLan 3010

### CaLan 2010B and 3010B

#### Fast, Accurate Carrier Level Analysis

The CaLan 2010B is a field-rugged, easy-to-use signal measurement device that maintains accuracy in all environmental conditions. The 2010B comes with a standard frequency range of 5 MHz to 1 GHz and four modes of operation: single channel, four channel, spectrum scan, and a time-saving channel scan (60 channels in less than two seconds).

Programmed unattended measurements store results to 90 internal memories. Each memory will store picture and sound information for up to 158 channels. This data can also be analyzed by the built-in FCC Pass/Fail compliance reporter. The Pass/Fail report criteria is also user definable. Comparisons of levels over time can be done with the "normalize" and "motion on screen" functions.

The CaLan 3010 family combines the power of the 2010B with sweep features. This solution offers a system maintenance tool coupled with powerful measurement and signal analysis in one easy-to-use lightweight package.

### CaLan Sweep/Ingress Analyzer

The CaLan sweep/ingress analyzer gives you confidence that your cable system is operating reliably by helping you to eliminate ingress. Designed with ingress in mind, this new solution consists of a portable field unit (CaLan 3010R) and a rackmount headend unit (CaLan 3010H).

When ingress corrupts return-path communication, the 3010H instantly detects the problem and transmits a "picture" of the ingress through the forward data pilot. This image will be displayed on the 3010R so your technician can begin troubleshooting immediately. The 3010H can support up to ten 3010Rs simultaneously. The display will advise you which 3010Rs are currently active in the field.

With the addition of Option 052 forward dual path option, you'll be armed with a complete forward, reverse sweep and ingress analysis tool. The forward sweep is still compatible with the 1777 transmitter.

#### Specifications Summary

##### Digital Signal Power Levels

Formats: QAM, QPR (DMX), QPSK, and VSB  
Amplitude Accuracy:  $\pm 1.5$  dB (typical)

##### Frequency

Range: 5 MHz to 1 GHz  
Accuracy:  $\pm 25$  kHz  
Resolution: 10 kHz  
Tuning Configuration: Standard, Off Air VHF/UHF, HRC, IRC, SECAM, PAL, and user-defined  
IF Bandwidth: 230 kHz  
Video Bandwidth: 300 kHz, automatic 10 Hz in C/N

##### Level

Range:  $-45$  to  $+70$  dBmV  
Accuracy  
Calibrator:  $\pm 0.25$  dB @ 113.36 MHz,  $\pm 0.2$  MHz  
Frequency Flatness:  $\pm 0.5$  dB  
Attenuator:  $\pm 0.5$  dB  
Log Linearity:  $\pm 0.5$  dB  
Typical Overall Accuracy:  $\pm 1.0$  dB

Resolution: 0.1 dB  
Difference Range: 0–25 dB  
Relative Accuracy:  $\pm 0.75$  dB  
Input Impedance: 75 ohms  
Input Match:  $> 14$  dB, 0 dB attenuation;  $> 20$  dB, attenuation  $> 0$  dB

##### Hum

Range: 0.5 to 5%  
Resolution: 0.1%  
Accuracy:  $\pm (0.2\% + 30\%$  of reading)

##### Carrier-to-Noise (with external preselector)

Range: 50 dB typical; 55 dB typical, measured in-band with carrier off  
Accuracy:  $\pm 2$  dB  
Repeatability:  $\pm 1$  dB

##### General

Size: 3010H: 133 mm H x 483 mm W x 292 mm D (5.25 in H x 19 in W x 11.5 in D)  
3010R: 317 mm H x 95 mm W x 267 mm D (12.5 in H x 10.5 in W x 3.75 in D)  
Weight: 3010H: 4.31 kg (9.5 lb);  
3010R: 4.8 kg (10.7 lb) with battery  
Power: 3010H: 90 to 264 Vac, 47 to 63 Hz, 20 VA max.;  
3010R:  $+10$  to  $+15$  Vdc @ 550 mA max.  
Battery: 12 V (1.9 AH) rechargeable lead acid  
Usage Time: 4 hrs. continuous; 12 hrs. typical; battery-saving sleep mode for 3010B  
Display Area: 127 mm x 33.8 mm (5.00 in x 1.33 in)  
Resolution: 240 x 64 pixels  
Type: LCD with EL backlight  
Temperature  
Operating: 3010H:  $0^\circ\text{C}$  to  $+55^\circ\text{C}$ ; 3010R:  $-20^\circ\text{C}$  to  $+55^\circ\text{C}$   
Storage: 3010H and 3010R:  $-20^\circ\text{C}$  to  $+70^\circ\text{C}$

##### Fiber Power Meter Option

Wavelength: 1310 and 1550 nm  
Measurement Range:  $-38$  to  $+20$  dBm @ 1310 nm;  
 $-38$  to  $+18$  dBm @ 1550 nm  
Resolution: 0.1 dB  
Accuracy:  $\pm 5\%$   
Display: dB, dBm, mW, microW, nanoW  
Connector Styles: ST, FC, biconic, D4, SMA, or bare fiber, rotary splice, RM

#### Ordering Information

- 85960B CaLan 2010B SLM Plus  
Opt 020 Fiber Power Meter
- 85961B CaLan 3010B Sweep/SLM Plus  
Opt 020 Fiber Power Meter
- 85962A CaLan 3010R Sweep/Ingress Analyzer  
Opt 052 Dual Path Sweep
- 85963A CaLan 3010H Sweep/Ingress Analyzer  
Opt 030 Cable TV Data Management Software with FCC Reports  
Opt 031 Cable TV Data Management Software  
Opt 050 Forward Sweep Transmitter  
Opt 052 Dual Path Sweep



85724A  
8590  
E-Series

- RF and video tests for broadcast transmitters
- One-button, non-interfering measurements
- Wide selection of frequency coverage, options
- Easily upgraded with circuit cards and DLPs



85724A and 8591E

## Broadcast Transmitter Testing with the 8590 E-Series Spectrum Analyzers

The 85724A broadcast television measurement personality provides an 8590 E-series spectrum analyzer with one-button measurements that simplify the installation, maintenance, and troubleshooting of TV broadcast transmitters. You can perform nearly all RF and three-key video measurements without interrupting your system, offering you convenience while keeping your customers happy.

A simple process configures the spectrum analyzer to work with your particular TV system. User-definable parameters include TV standard, default ITS lines, and noise-power bandwidths. You can tune to channels by entering the channel number and band; non-standard TV channels or FM radio channels can be measured using the frequency tuning mode. The broadcast TV measurement personality supports PAL-I/B/G, NTSC-M, and SECAM-D/K formats.

### RF and Video Measurements at the Push of a Button

The 85724A broadcast TV measurement personality provides the following tests:

#### RF Measurements

- Automatic tuning of vision, sound, and FM broadcast carriers
- Vision and sound carrier levels and frequencies (including NICAM for PAL-B/G/I)
- Vision to chrominance level
- Vision in sound (AM on FM)
- NICAM intermodulation (PAL-B/G/I)
- Intermodulation products
- Three-tone intermodulation test
- Spurious signals
- Depth of modulation (frame by frame)
- Depth of modulation (ITS line)
- Low-frequency error (hum)
- Field sync distortion
- FM deviation
- Carrier-to-noise ratio
- Simultaneous TV picture and sound<sup>1</sup>

#### Video Measurements<sup>1,2</sup>

- Differential gain
- Differential phase
- Chrominance-to-luminance delay inequality

### Advanced Analyzer Features

The spectrum analyzer's built-in features include trace math, limit-line testing, Fast Fourier transforms, and storage for up to 50 traces and states. Adjustable markers display the amplitude and frequency of any signal; zero span markers display amplitude and time or inverse-time information. A built-in memory card reader allows you to store and load application-specific programs. Other features include local oscillator output option for compatibility with sideband adapters, optional GPIB or RS-232 programming with a parallel printer port for direct printer or plotter output.

### Flexible Operation

A built-in card cage allows you to add circuit-card options at any time for increased measurement capability. There are two important circuit-card options for broadcast TV measurements. Option 301 Fast Time Domain Sweeps adds Analog+, TV line triggering, and AM/FM demodulation to the analyzer. Option 107 TV Receiver/Video Tester adds capability to display TV pictures and to perform video measurements, and it provides time gating for non-interfering carrier-to-noise testing.

### Bundled Options

You can order the spectrum analyzer and options individually (see Ordering Information), or you can order one of four system bundle options for a cost savings.

System Bundle Options	8591E 9 kHz to 1.8 GHz		8593/4/5/6E See Note	
	E80	E81	E85	E86
Preloaded 85724A Broadcast Measurement Personality	•	•	•	•
AM/FM demod. plus TV line trigger	•	•	•	•
Fast time domain sweeps	•	•	•	•
Analog+ display mode	•	•	•	•
Precision frequency reference	•	•	•	•
RS-232 and parallel interfaces	•	•	•	•
Rugged carrying case	•	•	•	•
Built-in 20 dB preamplifier	•	•	—	—
TV receiver/video tester	—	•	—	•

Note:  
8594E, 9 kHz to 2.9 GHz  
8595E, 9 kHz to 6.5 GHz  
8596E, 9 kHz to 12.9 GHz  
8593E, 9 kHz to 22/26.5 GHz

### Ordering Information

**85724A** Broadcast TV Measurement Personality (for use with 8590 E-series spectrum analyzers)  
**Spectrum Analyzer** (choose one)  
**8591E, 8593E, 8594E, or 8596E** Portable Spectrum Analyzer (See page 245 for prices and additional options.)

#### Options

- Opt 041** GPIB and Parallel Printer Interfaces
- Opt 043** RS-232 and Parallel Printer Interfaces
- Opt 301** Fast Time Domain Sweeps, TV Trigger and AM/FM Demod, ANALOG+ Display
- Opt 107** TV Receiver/Video Tester
- Opt 180<sup>3</sup>** PAL/SECAM/NTSC Picture Display
- Opt H02** LO Output (8591E without Option 010)<sup>4</sup>
- Opt H28** Amplified LO Output (8591E with Option 010)<sup>4</sup>

#### Recommended Accessories

- 85702A** Additional 128K RAM Card
- 85901A** Portable AC Power Source

<sup>1</sup>Requires Options E81, E86, or 107

<sup>2</sup>Requires Options E81, E86, or 107 and 301

<sup>3</sup>Incompatible with Option 107

<sup>4</sup>LO output compatible with sideband adapter

For more information on compatible printers, visit:

<http://www.agilent.com/find/pcg>



**Board Test & Inspection Systems** 518

**Functional Test** 519

**Semiconductor Test Systems** 520

*See also*  
Consulting Services 76

**Semiconductor Measurement Instruments** 523

**Data Storage Test Systems** 526

**Additional Literature** 528

## Intelligent Test: Agilent's Enterprise-Wide Solution

Test and inspection, when correctly implemented, adds value to the manufacturing process. Agilent has a healthy tradition of providing manufacturers with the best-in-class test and inspection systems that are the foundation of that value. This was true when Agilent made only one in-circuit solution and it is true today for the diversity of systems we build, from simple automated optical inspection to highly complex functional test platforms. That diversity gives you more opportunity to find a solution that fits your particular set of challenges, including a distributed test strategy that uses more than one type of test system. Now Agilent is building on its tradition of great measurements to help you do more with the data you get from Agilent systems, make them work together more efficiently. Agilent AwareTest xi is the first manifestation of that.

### AwareTest xi Software

This software solution links in-circuit and x-ray test, enabling the ICT system to "know" what the x-ray system has already inspected. The ICT system then adjusts its test suite accordingly, eliminating redundant tests. This not only speeds overall test and inspection time, it also permits the testing of very high node count boards on the ICT system without expensive, complex fixtures because it reduces the total number of test points required for in-circuit test. A 6,000 node board can be tested on a 3,000 node tester. This software makes the most of each system's unique strengths. The x-ray system verifies the structural integrity of solder joints; the ICT system verifies electrical integrity.



### Agilent TestWise SPC Software

As part of the Agilent Intelligent Test Strategy, TestWise SPC software provides access to the data flowing from your test systems so you can control it and apply it in real time.

TestWise SPC software integrates two primary features that allow you to control, share, and apply the valuable data you collect with Agilent test systems.

- Open platform technology assures that any quality application—whether commercial, custom, or proprietary—can accept data from Agilent testers and repair stations.
- A built-in charting tool provides basic SPC (statistical process control) and SQC (statistical quality control) charting capabilities.

TestWise SPC software puts relevant test data to work. Whether you use the built-in charting tool or send data to your existing quality applications, you can now perform trend analysis, fault diagnosis, process tuning, and other critical functions using real-time data from Agilent test and inspection systems.

## 3070 In-Circuit Test

This is the most popular in-circuit test system on the market today. It is available in models that range from outstanding measurements at a minimal cost to thorough fault detection at a competitive price. Agilent has extended the range of in-circuit test by lowering the cost and complexity of in-circuit fixturing and increasing the system's ability to perform thorough tests even with as little as 50% electrical access. The 3070 can be used on its own, or combined with the 5DX in a distributed test strategy with a link provided by AwareTest xi.

## 5DX X-Ray System

Designed for inline test the 5DX brings automated x-ray inspection (AXI) up-to-speed for the vast majority of manufacturing environments.

The 5DX accelerates test throughput by quickly capturing cross-sectional 3D images, and uses high-speed processors to analyze the images to locate faults.

Without any electrical access or fixturing, the 5DX rapidly detects a wide range of defects, including shorts, opens, insufficient solder, and inadequate solder bonds, even on the most complex boards. Its x-ray laminography technology is able to see through obstructions, enabling it to inspect obscured parts and double-sided boards in a single pass. The 5DX can be used on its own, or combined with the 3070 in a distributed test strategy with a link provided by AwareTest xi.



## BV3000 Automated Optical Inspection Systems

The BV3000 system speeds up the manufacture of printed circuit boards by automating the visual inspection process and improving fault detection. Rapidly capturing optical images of the device under test, this system automatically analyzes the images with 95% repeatability. The BV3000 improves early fault detection of common manufacturing process faults such as misaligned or misplaced components and gross solder defects. This system is particularly appropriate to test the manufacture of high volume, low-to-medium complexity loaded printed circuit boards such as those found in personal computers, printers, disc drives and modems.

## Ordering Information

Prices depend on system configuration. Please contact the Agilent Call Center in your region for assistance.

**BV3000** systems start at  
**5DX** Series II systems start at  
**3070** Series 3 systems start at  
**AwareTest xi** Software

BV3000  
5DX  
3070  
Series 3  
Aware  
Test xi

- The power of Intelligent Test technology—Agilent Intelligent Test is—based on test systems that are aware of each other and that interact in complementary ways to eliminate redundancies, increase test speeds, and reduce test costs.
- Unique Agilent AwareTest solutions employ knowledge of previous steps in the test process to provide measurable improvements in test cost, test coverage, and time to market.
- Agilent TestWise solutions deliver the right information to the right people, quickly enough to make a difference. Open access to information and standardized programming not only reduce the time and cost of developing new systems but provide better insight into production line performance as well.
- World-class test instruments and systems with an unmatched ability to provide reliable, repeatable measurements for better decision making.

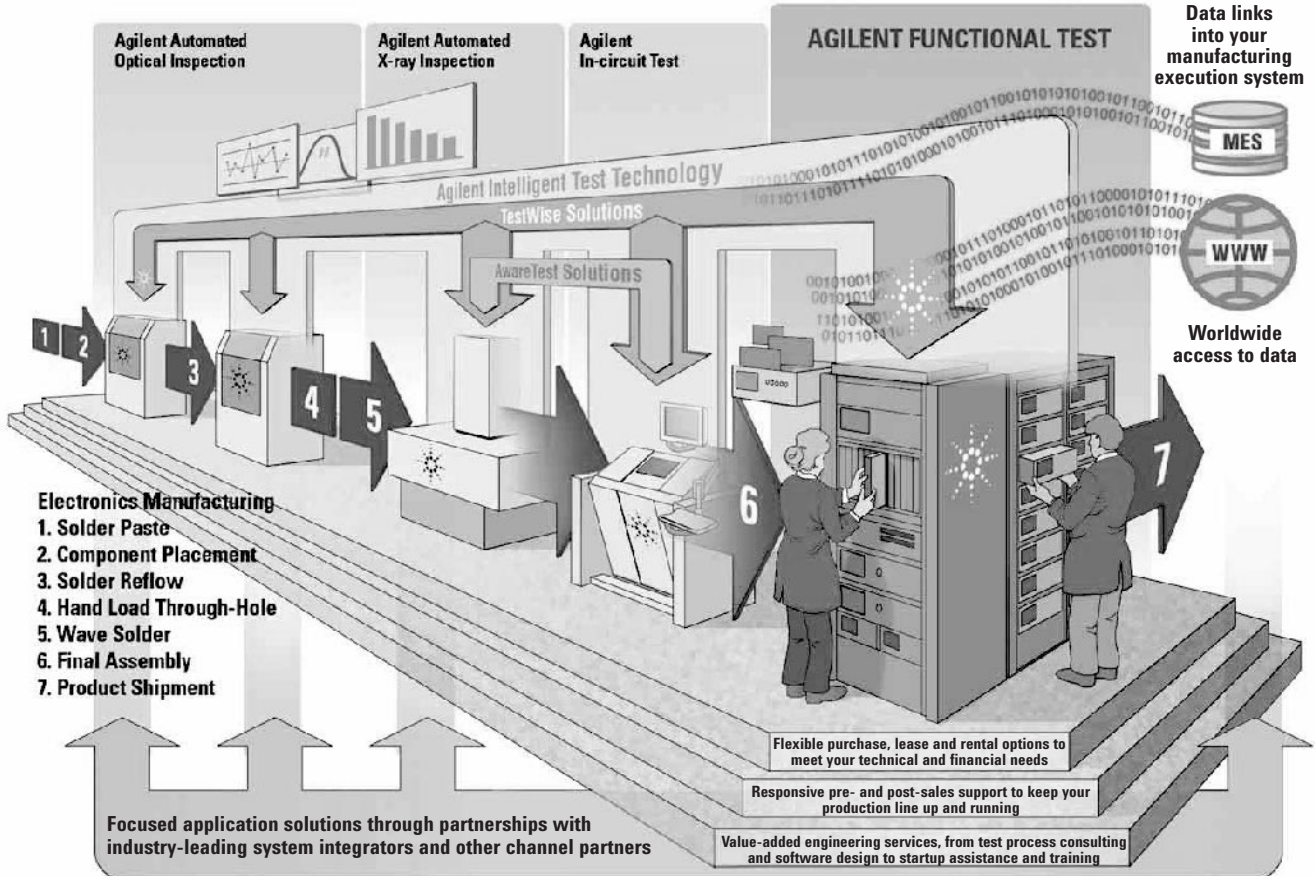

### Helping You Take Control with Optimized Test Solutions

As the demands on electronic test increase with every generation of new products, our goal is to provide the equipment and information you need to create efficient, flexible manufacturing test solutions. You can turn to Agilent for a portfolio that spans optical and x-ray inspection through in-circuit and functional test—and a practical strategy for tying it all together.

As we complete the transition from Hewlett-Packard to Agilent Technologies, we're excited by the opportunity to return to our roots in test and measurement, concentrating all our energies on the needs of engineers. With more than sixty years of experience in electronic test, we're building on the HP heritage of quality and innovation with a new organization focused on serving test engineers.

The new 2000 Electronic Manufacturing Functional Test Products and Services catalog focuses on the functional test stage, featuring the broadest range of products in the test and measurement industry.

- Simplify the process of bringing new systems on line
- Increase throughput with measurement speed, simplified procedures, and greater test capacity
- Reduce the risk of downtime with increased reliability, reduced operator delays, and dependable support
- Reduce the risk of mistakes with industry-leading accuracy, resolution, and repeatability
- Lower your total cost of ownership through competitive product pricing, higher throughput, dependable product designs, and support policies that include no-cost operational advice

Learn more about Agilent's world-class solutions for optical inspection, x-ray inspection, in-circuit test, and functional test by ordering the Electronic Manufacturing Catalog (see page 599), visit the web at: [www.agilent.com/find/manufacturing](http://www.agilent.com/find/manufacturing) or call your local Agilent office and discuss your application needs with our experienced test engineering team.

# Semiconductor Test Systems

520

## SOC, VLSI, Digital, Memory, Logic, Mixed Signal, RF, Semiconductor Parametric

83000  
93000  
94000

Agilent Technologies is the global leader in providing test systems to high-volume manufacturers of leading-edge electronic devices. Agilent is revolutionizing the role of semiconductor test by providing intelligent test solutions that give you the right test at the right cost with the power of information.

- SOC and VLSI Test Systems cover data rates up to 1.3 Gigabits per second and pin counts up to 1024 pins. The combination of the test processor-per-pin architecture, an algorithmic pattern generator per-pin, and a suite of real time analog measurement capabilities let you test SOC devices, embedded processors with a manifold of high speed busses, high speed serial interfaces, and embedded memory, as well as any kind of Multimedia, VLSI, PLL, and other state-of-the-art building blocks.
- Mixed-signal test systems offer a very low noise floor with DC-to-real-time DSP to RF capability along with up to 256-pin digital capability.
- Memory and Logic test systems lead the market in Rambus, wafer level testing of flash memory, non-volatile memory and field programmable devices.
- RFIC test systems, precision contactors, and wafer-probing solutions provide the ability to test RFICs and MMICs at RF frequencies at the test site up to 3, 18, or 45 GHz
- Semiconductor parametric test systems offer high throughput, with links to SPECS modeling software, and maximize the instrumentation close to the wafer for maximum precision



93000

### 93000 SOC Series IC System-on-a-Chip Production Test Systems for state of the art ICs

Production test of Systems-on-a-Chip (SOC), embedded processors and microprocessors

- High-speed bus testing for Rambus, Cache, PC133, and PC 266
- High-speed serial data testing for LVDS, Gigabit Ethernet, FireWire, Fiber Channel, and SONET
- Single scalable platform
- High Fidelity—lowest noise test environment
- Pay-per-use temporary and permanent upgrades
- Advanced mixed-signal testing
- PLL and frequency jitter testing
- Embedded memory testing
- Wide algorithmic pattern generator per-pin for memory testing
- Highest throughput test processor-per-pin architecture
- Up to 1 Gbit/sec data rate for “at-speed” testing
- Up to 960 digital pins plus 4 analog instruments
- Timing flexibility with “Change Waveform on the Fly”
- High-speed DRAM and SRAM testing
- Easy and efficient docking to handlers and probers for TCI
- Multisite testing capability up to 32 sites

For more information, contact your Agilent sales representative or visit our web site: [www.agilent.com/find/semiconductor](http://www.agilent.com/find/semiconductor)



83000

### 83000 Series VLSI IC Production Test Systems for “At-Speed” Test of State-of-the-Art ICs

Production test of microprocessors (CISC and RISC)/micro-controllers/VLSI/ASIC/Rambus ICs/Telecom ICs/Multimedia ICs/FSRAM/RDRAM

- Up to 1.3 Gigabits per second data rate for “At-Speed” test
- Up to 1024 digital and analog pins
- Up to  $\pm 50$  ps measurement accuracy
- High speed memory interface testing
- Algorithmic pattern generator per pin for memory testing
- High Speed DRAM and SRAM testing
- Multisite testing capability up to 32 sites

For more information, contact your Agilent sales representative or visit our web site: [www.agilent.com/find/semiconductor](http://www.agilent.com/find/semiconductor)

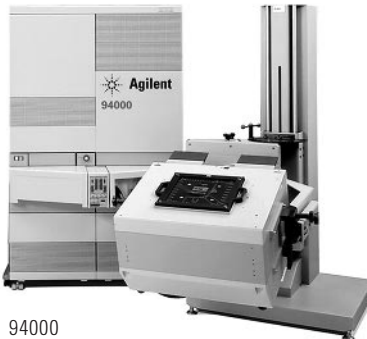

94000

### 94000 Mixed Signal IC Test System for Testing Telecom, Data Management, RF and Photo Imaging ICs

Production test IC test solutions for wireless and wired communications, graphics controllers, high speed PMRL HDD, integrated PC audio, digital subscriber line (xDSL), ATM, A/D, DAC, and a specialized test option for photo imaging ICs, the 94000IP.

- Sourcing up to 3GHz and measuring up to 6Ghz
- Up to 256 pins at 532Mbps digital capability
- Excellent analog performance with low noise floor
- Full analog/digital synchronization
- Multisite testing capability
- Graphical software environment for rapid test development

For more information, contact your Agilent sales representative or visit our web site: [www.agilent.com/find/semiconductor](http://www.agilent.com/find/semiconductor)

### Semiconductor Integrated Workcell Solutions

- Integration services of handlers and wafer probers
- RFIC fixturing
- Memory test fixturing
- Utilization measurement and analysis products

For more information, contact your Agilent sales representative or visit our web site: [www.agilent.com/find/semiconductor](http://www.agilent.com/find/semiconductor)





95000

### 95000 HSM Series 32-Site, Production-Ready, Integrated Test Cell for High Speed DRAM NEW

- High throughput production testing of up to 32 devices in parallel on a single test head
- Unique test processor-per-pin architecture provides maximum flexibility for developing complex protocol-based test patterns.
- Per-pin algorithmic pattern generator (APG) generates at-speed patterns up to a data rate of 1 GHz.
- 1 GHz algorithmic patterns, 1 GHz logic vectors, and 1 GHz error capture, on every pin across all test sites without pin multiplexing or pattern generator interleaving, provides true at-speed production testing.
- 1 M vector memory per pin for complex memory interface testing.

For more information, contact your Agilent sales representative or visit our web site: [www.agilent.com/find/semiconductor](http://www.agilent.com/find/semiconductor)

### Custom Support Products and Services for Semiconductor Test

- Global application development centers
- Remote support
- Test program development and conversion
- System integration
- Scheduled and on-site maintenance and user training
- Flexible support service levels
- Custom services and support for 365-day/24-hour operations
- Escalation management
- Performance improvement/process consulting
- IC device characterization services
- Application measurement consulting
- Calibration services
- Site preparation and verification
- Installation and system relocation and moves
- Spare parts
- Preventative maintenance

For more information, contact your Agilent sales representative or visit our web site: [www.agilent.com/find/semiconductor](http://www.agilent.com/find/semiconductor)

### Semiconductor Integrated Workcell Solutions

- Integration services for handlers and wafer probers
- RFIC fixturing
- Memory test fixturing
- Utilization measurement and analysis products

For more information, contact your Agilent sales representative or visit our web site: [www.agilent.com/find/semiconductor](http://www.agilent.com/find/semiconductor)



V1300

### Versatest Series Mixed Memory/Logic IC Production Test Systems for Flash and Other Nonvolatile Memory Devices.

#### Versatest Series V1300 Unique Features

- True 16-site test system ensures the highest-throughput, lowest-cost production wafer sort for nonvolatile memory.

#### Versatest Series V1300 and V3300 Standard Features

- Tester-per-site architecture for high-throughput testing.
- Combined resource mode ensures test floor flexibility for testing devices with pin counts of up to 128.
- Ability to test both memory and logic addresses the complex test requirement of nonvolatile memory products.
- Channel assignment module (CAM) provides software flexibility for assigning any APG address or data channel to any I/O channel; and any I/O channel to any error catch RAM (ECR) channel.
- Standard interfaces for Electroglas, TSK, and TEL wafer probers.



V3300

### Versatest Series V3300/V3300AD Unique Features

- True 8-site test system with 20 MHz data rates and 100 ps typical edge placement ensures the highest-throughput, lowest-cost production wafer sort for nonvolatile memory where critical AC specifications for memory data patterns must be verified during wafer sort.
- Address doubling (AD) option allows 16 devices to be tested on 8 sites for higher throughput with a minimal incremental increase in system cost.
- Handler interface available for final test applications.

For more information, contact your Agilent sales representative or visit our web site: [www.agilent.com/find/semiconductor](http://www.agilent.com/find/semiconductor)

95000  
V1300  
V3300

4070 Series  
84000



4073A

## Agilent 4073A Ultra Advanced Parametric Test System

The flagship of the Agilent 4070 series for developing and monitoring advanced IC fabrication processes:

- High system reliability and uptime (MTBF greater than 10,000 hours)
- High test throughput for all measurements
- Precise accuracy, resolution, and repeatability
- Simplified flash memory cell test (optional)
- Ring oscillator evaluation (optional)
- Complete, easy-to-use wafer level reliability (WLR) solution (optional)
- Agilent SPECS common test shell for the Agilent 4070 series
- Built-in diagnostics for quick solutions to problems
- Direct docking to probe card for optimum performance
- Laminar air flow for clean room operation

For more information, contact your Agilent sales representative or visit our web site: [www.agilent.com/find/semiconductor](http://www.agilent.com/find/semiconductor)

## Custom Support Products and Services for Semiconductor Test

- Global Application Development Centers
- Remote Support
- Integration Services of Handlers and Wafer Probers
- Test Program Development and Conversion
- System Integration
- Scheduled and On-Site Maintenance and User Training
- Flexible Support Service Levels
- Custom Services and Support for 365 Day/24 Hour Operations
- Escalation Management
- Performance Improvement/Process Consulting
- IC Device Characterization Services
- Application Measurement Consulting
- Calibration Services
- Site Preparation and Verification
- Installation and System Relocation and Moves
- Spare Parts
- Preventative Maintenance

For more information, contact your Agilent sales representative or visit our web site: [www.agilent.com/find/semiconductor](http://www.agilent.com/find/semiconductor)

## Semiconductor Integrated Workcell Solutions

- Integration Services of Handlers and Wafer Probers
- RFIC Fixturing
- Memory Test Fixturing
- Utilization Measurement and Analysis Products

For more information, contact your Agilent sales representative or visit our web site: [www.agilent.com/find/semiconductor](http://www.agilent.com/find/semiconductor)



84000

## 84000 RFIC Test Systems for Testing RFICs and MMICs Used in Wireless Systems

- Production- and R&D characterization testing of RFICs and MMICs
- Up to 3 GHz, 18 GHz, or 45 GHz solutions available
- Configurations with up to 12 RF ports to test LNAs, up/down converters, power amplifiers, integrated transmitters, receivers, and complete transceivers
- Error-corrected S-parameters, noise figure, ACPR, and EVM measurements
- Simplified graphical user interface for rapid test plan development
- Simplified RF calibration
- Complete packaged-DUT fixturing available to 18 GHz, including the YieldPro Contactor, and on-wafer solutions to 45 GHz
- Customer-proven measurement results that correlate to R&D bench instrumentation

For more information, contact your Agilent sales representative or visit our web site: [www.agilent.com/find/semiconductor](http://www.agilent.com/find/semiconductor)

- High-resolution/accuracy and wide range.  
I: 1fA to 1A (20fA offset accuracy), V: 0.2 $\mu$ V to 200V
- Fully automated I-V sweep measurements with dc or pulse mode, expandable up to six SMUs
- Synchronized stress/measure function, two high-voltage pulse generator units ( $\pm 40$ V)
- Capacitance measurement utilizing a ramp voltage (quasi-static C-V measurement)
- Time-domain measurement: 60 $\mu$ s to variable intervals, up to 10,001 points
- Easy to use: knob-sweep similar to curve tracer, automatic analysis functions
- System integration: interactive control of E5250A low leakage switching mainframe
- Automation: built-in Instrument BASIC, trigger I/O capability

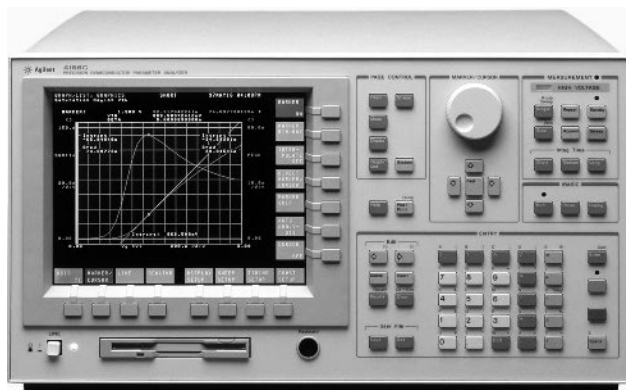

4155C Semiconductor Parameter Analyzer

Whether you are looking for a low-cost bench-top instrument or an automated test system, Agilent can meet your semiconductor test needs with its Just-Enough-Test line of semiconductor measurement instruments. This instrument family provides versatile coverage of application needs in process development, device characterization, process monitoring, reliability testing, failure analysis, and incoming inspection. The low leakage switching matrix, various useful accessories, and Windows-based interactive characterization software allow the instruments to be flexibly configured from a one-box solution to an integrated, automated system.

### 4155C Semiconductor Parameter Analyzer 4156C Precision Semiconductor Parameter Analyzer

The 4155C and 4156C are the next generation in precision semiconductor parameter analyzers. You get the best digital sweep parameter analyzer plus a reliability tester, a powerful failure-analysis tool, and an automated incoming inspection station, all rolled into a single instrument.

This new family was explicitly designed to provide unprecedented accuracy and functionality for evaluating your sub-micron geometry devices. With one flexible instrument, you can improve your semiconductor quality starting with material evaluation and device characterization and going all the way through to the final packaged part inspection and field failure analysis.

### Choose the Right Solution

The 4155C/56C offers four built-in source/monitor units (SMUs), two voltage source units (VSUs), and two voltage monitor units (VMUs). The 4155C is best suited for basic semiconductor applications with its non-Kelvin connections, 10 fA/0.2  $\mu$ V resolution, and 100 mA/100 V measurement range. For critical low-level characterization, the 4156C extends current resolution to 1 fA and accuracy to 20 fA. The 4156C utilizes full-Kelvin remote sensing on each SMU.

You can add the 41501B SMU and Pulse Generator Expander, which is supplied with a 0 V/ 1.6 A Ground Unit, at any time. The expander accepts two 100 mA/ 100V SMUs or one 1 A/ 200 V SMU, and two specially synchronized 40 V/ 200 mA/ 1  $\mu$ s pulse generators.

Now you can also make quasi-static C-V measurement, using a ramp voltage, to measure and evaluate semiconductor devices and processes.

### Setup and Measurement

The 4155C/56C can perform staircase and pulse sweep measurements, and sampling (time-domain) measurements using any of several measurement units, including units in the 41501B, without changing connections. You can easily perform a stress-measure cycling test in reliability evaluations such as hot carrier injection and flash EEPROM tests.

Setup is made easy through the use of setup pages. All you have to do is fill in the blanks using the front-panel keys, keyboard, or GPIB (SCPI commands and Agilent FLEX, Fast Language for Execution). You can also measure and find setup conditions instantly by using the knob sweep capability, which is similar to curve tracer operation.

Using the front panel of the 4155C/56C you can control the E5250A low leakage switching main frame. The conditions of the cross point are displayed, you select the cross point whose condition you want to change, and connect or disconnect it interactively. This functionality allows the 4155C/56C to provide a complete measurement solution, including E5250A low leakage switching, without any external computer.

### Display and Analysis

The measurement and analysis results are displayed on the color LCD, and, for comparison purposes, you can superimpose stored graphics from four graphic memories. A number of powerful graphical analysis tools make it easy to analyze and extract many parameters such as hFE and Vth.

Once you find the parameter extraction conditions, you can automatically get the parameter using the automatic analysis function.

### Output and Storage

Setup, measurement, and analysis data can be output via GPIB, parallel or network interface (10 Base-T LAN) to a color plotter and printer. You can save the data on a disk via the network or on a 3.5-inch disk in MS-DOS or LIF format. The graphic (HP-GL, PCL or TIF) output file formats allows you to transfer graphics to desktop publishing software.

### Repeating and Automating Tests

The Instrument BASIC controller built into the 4155C/56C can construct an automatic measurement system using external instruments without a controller. The 4155C/56C can be synchronized with external instruments using the versatile trigger I/O functions.

Users of the 4155C/56C who prefer programmatic languages such as C/C++ or BASIC, will appreciate the capabilities provided by Agilent Fast Language for Execution (FLEX). Agilent FLEX allows direct control of the instrument hardware, eliminating the need to use SCPI commands. Agilent FLEX gives you the speed, flexibility, and ease of program creation that you need for the most demanding automated test situation.

Product	Applications							
	Basic I-V	Low Current	Ultra Low Current	High Voltage & Current	Pulsed Meas.	Time Domain Meas.	Multi-freq. Meas.	Quasi-Static C-V
4155C	v	v			v	v		v
4156C	v	v	v		v	v		v
4142B	v	v		v	v			
4284A							v	

Agilent Semiconductor Measurement Instruments for Applications

E5250A  
4155C  
4156C

### E5250A Features:

- Unique analog bus architecture to allow configuration as a 10 x 48 cross-point matrix or as a 384-channel multiplexer
- 100 fA offset current with 10 tera- $\Omega$  channel isolation for accurate current measurement
- 100  $\mu$ V offset voltage and low contact resistance for accurate voltage measurements
- Plug-in module architecture



E5250A with 4156C

### E5250A Low Leakage Switch Mainframe



The E5250A switch mainframe has four slots for one to four 10 x 12 cross-point matrix modules or one to four 24-channel multiplexer modules. The cross-point matrix provides an automated solution for general parametric measurements while the multiplexer is ideal for long-term reliability measurements. The unique analog bus architecture ensures low noise internal interconnection of the plug-in modules without external cables. The four backside slots provide a maximum of 48 matrix outputs (one mainframe with four matrix modules installed) or 384 multiplexer outputs (four mainframes with four multiplexers installed in each mainframe).

When configured as a 10-input cross point matrix, this configuration is ideal for general parametric measurements. It provides six I-V triaxial inputs, which are two low leakage performance ports (100fA) and four general ports, two high frequency inputs (up to 10MHz) and two capacitance ports. The cross point matrix enables users to avoid manually changing the probe tips each time. Fast, accurate and repeatable characterization and evaluation of semiconductor devices is now possible without sacrificing performance.

When configured as a multiplexer, each module has 24 channels with an isolated external multilevel dc bias voltage input for each set of eight channels. If a device breaks down, other devices are protected by the user-selected protection resistor in each channel to dampen the surge. The E5250A provides a 384-channel system with long-term reliability.

### Reliability Test

Agilent 4155C/4156C parametric analyzers are configured so they can expand from a one-box solution to an integrated, automated measurement system complete with a low leakage switch.

Traditional reliability testing requires the testing and monitoring of hundreds of device structures as they undergo electrical and thermal stress. Engineers typically define a device lifetime as the time it takes a transistor parameter, such as  $V_{th}$ , to shift by 10% from its initial value. Hundreds of hours of stress can be required for this to occur, so it is critical a test system has enough channels to test a large number of devices in parallel. The 4155C/4156C analyzer can directly control the bias voltage and the E5250A switch/multiplexer unit. The 4155C/4156C also has the speed and sensitivity to determine when a device has degraded. The user can group multiple E5250A units together to create a system with up to 384-channels. Special wide-temperature cables allow testing at elevated conditions. The 4155C/4156C and E5250A switch can handle your most demanding reliability measurements.

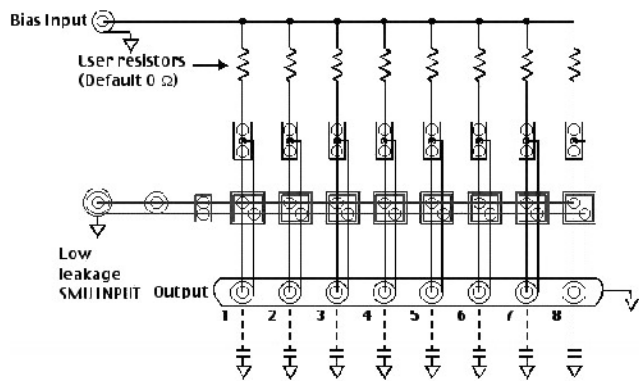

The multiplexer block diagram for reliability testing in parallel.

### Hot carrier injection (HCI) test

Hot carrier injection tests require a voltage stress to be repeated until a device parameter degrades by a predetermined amount. The 4155C/4156C and E5250A reduces this tedious procedure to only two keys; stress and measure. The user can also create files to automate the stress/measure procedure.

### Oxide Integrity Testing

The charge-to-breakdown (Qbd) measurement provides data on the quality of the oxide insulation of a process. The 4155C/4156C and E5250A have several powerful built-in routines that allow users to determine Qbd.

### Key Literature

- Evaluation of Hot Carrier Induced Degradation of Multiple MOSFET Devices, p/n: 5964-9113E
- Evaluation of Surface State Using Charge Pumping Methods, p/n 5964-2195E
- Evaluation of Oxide Reliability Using V-Ramp/J-Ramp Tests, p/n 5963-1248E
- Evaluation of Electromigration Using the SWEAT Procedure, p/n 5963-1110E



- Flexible, modular architecture
- Wide measurement range with high resolution  
V:  $\pm 4 \mu\text{V}$  to  $\pm 1000 \text{ V}$ , 0.05%  
I:  $\pm 20 \text{ fA}$  to  $\pm 10 \text{ A}$ , 0.2%
- Pulse measurement capabilities  
Pulse width 1 ms to 50 ms, 100  $\mu\text{s}$  resolution
- High-speed measurement (typical)  
Sourcing or monitoring: 4 ms  
V<sub>th</sub>, hFE extracting: 12 ms
- Internal memory  
Program memory: >2000 commands (typical)  
Data memory: 4004 measurement points



4142B Modular DC Source/Monitor

4142B  
E5230C

### 4142B Modular DC Source/Monitor

Offering a wide measurement range and excellent sensitivity, the 4142B modular dc source/monitor is a system-use dc measurement instrument especially designed for high-throughput dc semiconductor testers. A completely user-definable system component, the 4142B features modular architecture that allows you to build a custom configuration to suit your measurement needs.

Eight plug-in module slots can accommodate any combination of the five presently-available modules; as new modules become available, you can upgrade your measurement capabilities with ease. Choose from two types of source/monitor units (SMUs) to force or measure up to  $\pm 200 \text{ V}$  and  $\pm 1 \text{ A}$ : a high-current source/monitor unit (HCU) up to  $\pm 10 \text{ A}$ , a high voltage source/monitor unit (HVU) up to  $\pm 1000 \text{ V}$ , a voltage source/voltage monitor unit (VS/VMU), and an analog feedback unit (AFU). The 4142B's instrument command and measurement data-storage capabilities, coupled with the high-speed GPIB interface, minimize computer loading, enhance throughput, and simplify systemization.

### Versatile SMUs and Reliable Measurement

For general-purpose dc or pulsed measurement, use the 41421B source monitor unit. The equivalent of four instruments, this precision module forces voltage up to  $\pm 100 \text{ V}$  and simultaneously measures currents down to 20 fA. It can also force currents up to  $\pm 100 \text{ mA}$  while measuring voltage down to 40  $\mu\text{V}$ .

If you test high-power components or desire a wider measurement range, use the 41420A source monitor unit. This versatile SMU can source  $\pm 200 \text{ V}$  or  $\pm 1 \text{ A}$  (14 W, dc or pulsed) and still maintain a measurement resolution of 40  $\mu\text{V}$  and 20 fA. Both SMUs include a compliance feature that limits output voltage, current, or power to prevent damage to your device. Each SMU (41420A or 41421B) acts as either a voltage source/current monitor or current source/voltage monitor. These complementary operating modes let you change the stimulus on a device without modifying the physical connections. This versatility reduces test time and eliminates instabilities caused by changing connections at the DUT.

### Test Power Devices to 10 A or 1000 V

The 41422A HCU and the 41423A HVU expand the measurement range of the 4142B to 10 A or 1000 V. They dramatically expand the 4142B's ability to test power devices, such as power transistors, power MOSFETs, GaAs FETs, and smart ICs. Using a combination of the two units respectively, measurements of up to 20 A or 2000 V are possible.

Using the HCU, fast pulse testing (100  $\mu\text{s}$  minimum pulse width) at high current increases test reliability by minimizing the effects of thermal drift. Quasi-pulsed measurements by the HVU are effective for measuring breakdown voltage by minimizing the duration of the break-down condition.

The 16087A module selector is a scanner that lets you remotely control the connection of the 41420A/41421B SMUs, the 41422A HCU, or the 41423A HVU to a test pin. It contributes to automatic testing for high-power devices with high-breakdown voltage. The built-in module selector can be specified as an option of the 16088B test fixture.

### High-Speed Parameter Extraction by Analog Feedback Technique

To find important parameters that are specified at a given voltage or current, such as V<sub>th</sub> or hFE, connect the 41425A AFU to two SMUs. The AFU modulates the output voltage of one SMU while monitoring the current or voltage of the other. Target currents and voltage are found with great speed (12 ms). This unique analog feedback network rapidly measures V<sub>th</sub>, hFE,  $\Delta L$ , or  $\Delta W$ —parameters that would require excessive test time on other parametric testers.

You can also use the AFU to bias and test microwave devices. It can be integrated into the network analyzer system.

By using the AFU, you can eliminate the effect of device thermal drift and can hold the initial setting bias for ac measurement time.

### Interactive Characterization Software (ICS)

The Windows-based E5230C Interactive Characterization Software (ICS) together with I-V, C-V and Switch Driver Libraries provide a uniquely powerful instrumentation control and data analysis software package. It provides true point-and-click measurements, an intuitive matrix control window, a built-in database, and graphical analysis. ICS delivers more than programming-free instrumentation control. The spreadsheet windows and scientific plotting capability allow you to view and analyze data easily. ICS also includes valuable scientific and engineering data reduction tools necessary for interpreting test results, such as cursor assignments and curve fitting routines. The resources of ICS include a robust file management system that allows you to create multiple databases without relying on external database software.

The I-V Parametric Library controls the 4155/4156, 4142B, 4145A/B and 4140B. The C-V Driver Library controls the 4284A, 4280A and 4275A. The Switch Driver Library controls the E5250A.

E5022A

- 1GHz System Read Channel Bandwidth
- 1Gbps(Mega bits per second) Arbitrary Data Pattern
- $\pm 30$  psec (typical) Write Current Edge Accuracy
- High Spinstand Accuracy
- Fast Test Throughput
- Available 800Mbps Bit Error Testing (option)
- Built-in System Calibration
- Hardware and Software Open Architecture



E5022A Hard Disk Read/Write Test System

### E5022A Hard Disk Read/Write Test System

The E5022A Hard Disk Read/Write Test System is a VXI based system and is the most advanced test system for the development and production of today's sophisticated MR and GMR heads (HGA: Head Gimbal Assembly). The combination of the measurement electronics and a high-performance spinstand enables easy use of the system without requiring any integration effort for the test system. The read channel bandwidth of the measurement electronics is greater than 1GHz. The 1Gbps data pattern generator, accurate write edge timing, and the high positioning performance of the Agilent spinstand cover the measurement requirements of the most advanced GMR heads. In addition to the high quality measurements, the E5022A makes measurements faster than you ever imagined. This speed dramatically improves the throughput in production lines.

#### Wide Bandwidth Measurements

The E5022A system, with Agilent's Universal Head Amplifier (UHA), provides wide bandwidth (1GHz) for evaluating advanced MR and GMR heads. The raw performance of the head or the head/media interface can be determined using the UHA. In addition, the flatness of  $\pm 0.3$  dB across the pass band ensures that measurements will be accurate and will not be corrupted by the test system.

#### Fast Measurement in the Production Line

The measurement speed of the E5022A is optimized by the hardware and software. The E5022A uses the index pulse from the spinstand to trigger all measurements. Because each measurement module has its own processor, processing overhead from the system controller is eliminated.

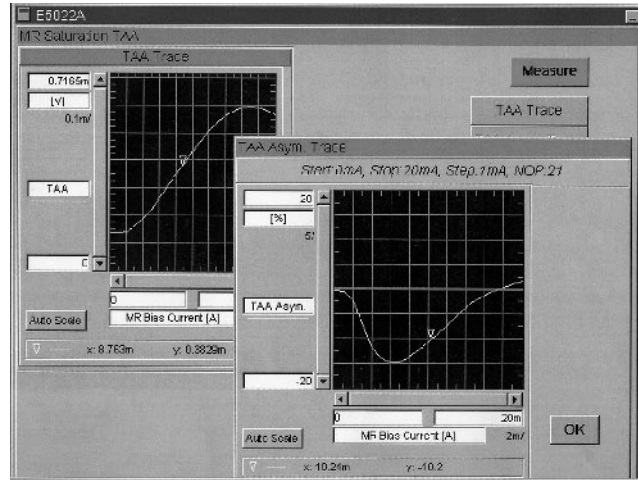

Measurement Display (TAA/TAA Asymmetry vs. MR Sense Current)

### High Performance Spinstand

Integrated into the E5022A is a high-performance spinstand. Split dual axis stage with the vacuum lock down feature and a piezo actuator on one axis ensures accurate, stable, and fast positioning capability. The dual axis air slider stages have a vacuum lock feature to maintain positioning repeatability. (0.28  $\mu$ inch (7nm), sigma).

### Open System Architecture

The E5022A's Open Architecture for both the hardware and software increases your measurement flexibility. The VXI based system hardware architecture provides the flexibility for adding a new VXI module to the existing system to meet with the new measurement requirements. In the software side, E5022A's proprietary tests and test sequences, data archive systems, and many other tools can be created using Agilent's DLLs (Dynamic Linked Libraries). The DLLs are compatible with Agilent VEE, Lab View, Visual Basic, C++, and many other software tools.

### Bit Error Measurements (E5039A)

800Mbps Bit Error testing can be performed by adding the E5039A module into the system. Customized PRML channel chip boards are supplied as options. Variables of a PRML chip can be accessible and programmed for the chip optimization or test requirements. With the outstanding positioning performance of the Agilent spinstand, the system can provide accurate and reliable bit error testing, such as 747 and Bathtub tests. (Note: Please contact your local Agilent Technologies sales office about available PRML channel chip boards.)

### Customization

Head and head/media testing often require customized fixtures, electronics, and/or measurement functions. Agilent can prepare custom electronics (for example, head amplifier boards and PRML chip board using commercially available chips, etc.) and custom HGA cassettes. Please contact your Agilent representative for details about your customization and support needs.

**E5022A Specification Summary****Write Characteristics****Data Clock:**

50Mbps – 1Gbps, 1kbps resolution

**Data Pattern:** HF, LF, Isolated, repetitive pattern, Pseudo Random pattern, NLTS 5<sup>th</sup> harmonic pattern, User defined pattern (128kbits [max], repetitive)**Read Channel Characteristics**Input Range: 200  $\mu$ Vp-p – 5mVp-p

Bandwidth: &gt;1GHz, @-3dB

Filters: Four selectable filters (E5029F)

**Measurement Accuracy:****MR DCR:**  $\pm 2\%$ **TAA:**  $\pm 3\%$  (typical) (for sinusoidal wave @ E5038A input)**Narrow Band TAA (by 4395A):**  $\pm 2\%$ **Pulse Width:**  $\pm 5\% + 150$ psec (typical)**Base Line:**  $\pm 5\%$  of TAAp-p (typical)**Overwrite:**  $\pm 0.2$ dB**NLTS:**  $\pm 2\%$ **Spindstand:****Spindle RPM:** 2400 – 20000 rpm**Clamp Size:** For 3.0/3.5", 2.5" disks**Spindle RPM Jitters:** 0.01% @  $\geq 3000$ rpm**Non Repeatable Runout:**  $< 0.4$  $\mu$ inch ( $< 10$ nm), 1sigma**Coarse Stage Repeatability:** 200 $\mu$ inch (5 $\mu$ m), 1sigma**Skew Range:**  $\pm 30$  deg.**Skew Accuracy:**  $\pm 1$  deg.**Fine Positioning Travel:** 600 $\mu$ inch (15 $\mu$ m)**Travel Resolution:** 0.1 $\mu$ inch (2.5nm)**Fine Positioning Accuracy:**  $\pm 2$  $\mu$ inch (50nm)**Fine Positioning Repeatability:**  $\pm 0.28$  $\mu$ inch (7nm), 1sigma @  $\pm 3$   $\mu$ m travel**General Characteristics****Operating Temperature and Humidity:** 23  $\pm 5$ ° C, 15%-80% RH, Non-condensation**Voltage:** 100/120/220/230/240 V  $\pm 10\%$ **Power Frequency:** 50/60 Hz**Air Supply Requirements :****Pressure and Flow:** 724 – 827 kPa, 0.00048 m<sup>3</sup>/s**Vacuum Requirements:****Pressure and Flow:** –70 kPa (min), 0.00022 m<sup>3</sup>/s**Physical Specifications:****Spindstand Size and Weight:** 1020mm H x 600mm W x 760mm D (40.8 in x 24 in x 30.4 in), about 300Kg (660 lb)**Rack Size:** 1600 or 2000mm H x 600mm W x 905mm D (64 or 80 in x 24 in x 36.2 in)**Necessary Working Space:** about 2m x 1.5m (6.6 ft x 4.95 ft)**Key Literature**Hard Disk Read/Write Test System Product Overview, p/n 5968-1580E  
E5022A Technical Specification, p/n 5968-1691ENOTE: The Agilent E5022A is a very high technology test system; for the latest information see our web site: [www.agilent.com/tm/pstm/English](http://www.agilent.com/tm/pstm/English)

E5022A

**Board Test & Inspection**

3070 Quick Verify Platform for ICT Plus  
Functional Product Verification

[5965-8060E](#)

It's About Time and Cost

[5966-3829E](#)

3279CT Communications Board  
Test System Photo Card

[5965-4879E](#)

It's About Time and Money—Agilent Automated  
Process Test Solutions

[5968-1859E](#)

5DX Series II automated x-ray inspection  
system improves product and process-  
in-line, off-line, real-time

[5966-3392E](#)

(PN 3070) Performance Port Fixturing Product

[5965-8567E](#)

(PN 3070) RPM Invitation, Color Piece

[5965-6622E](#)

**Semiconductor Test Systems**

Accurate and Effective Flash Memory Cell  
Evaluation Using the 4072A

[5968-6719E](#)

Testing Digital Series to Their Limits Data Sheet

[5962-7010E](#)

Versatest V3300/V3300AD Mixed Memory/  
Logic IC Test System

[5965-5635E](#)

Versatest V1300 Mixed Memory/Logic  
IC Test System

[5968-0524EN](#)

83000 Pay-Per-Use

[5964-0094E](#)

83000 Model F660 Can You Test Your Most  
Advanced Devices to Their Limits?

[5962-7011E](#)

84000 Series High Throughput RFIC Test Systems

[5965-5272E](#)

9490 Series Real Mixed-Signal Test Solutions  
for Production

[5963-7048E](#)

4072A Advanced Parametric Tester  
with Agilent SPECS

[5968-4196E](#)

(PN) Characterizing Communications ICs with  
the 83000 Model F660

[5962-9273EUS](#)

(PN) Memory Test Software Provides Cost-  
Effective Solutions to Testing Advanced  
SRAMs (83000 F660)

[5963-5078E](#)

**Semiconductor Measurement  
Instruments**

E5250A Low Leakage Switch Mainframe  
Setup Guide

[5964-4091E](#)

(PN 4156-1) Differences from 4155A/4156A

[5965-9846E](#)

(PN 4156-2) Configuring an NFS and Print  
Server for Network Capability

[5966-4184E](#)

(PN 4156-3) Prober Connection Guide

[5966-4185E](#)

(PN 4156-4) Advantages Over the  
4145A/4145B

[5968-6681E](#)

(PN) 4155A/4156A Semiconductor Parameter  
Analyzer—Edition 1 Programming Guide  
for 4145A/B

[5963-3201E](#)

(PN 4142B-1) DC Characterization of  
Semiconductor Power Devices

[5091-2744E](#)

(PN 4140A/B) 4140A 4140B Measurement Hints

[5950-2921](#)

**Data Storage Test Systems**

E5022A Hard Disk Read/Write Test System  
Profile

[5968-1580E](#)

E5022A Hard Disk Read/Write Test System  
Technical Specifications

[5968-1691E](#)

E5022A Hard Disk Read/Write Test System  
Configuration Guide

[5968-3402E](#)



*See also*  
Frequency & Time Standards 504  
Impedance Measuring  
Instruments 485  
Materials Test Equipment 491

**Data Acquisition Systems 530**

*See also*  
VXIbus Products 93

**Additional Literature 536**



## History and Applications

Agilent Technologies has provided data acquisition solutions for over 25 years. The earliest systems were combinations of multiplexing scanners and digital multimeters. These early rack mounted solutions evolved into today's powerful modular data acquisition and control systems capable of providing not only analog and digital measurement capabilities but also analog and digital output for a wide variety of applications. Data acquisition and control solutions are used extensively to evaluate electromechanical product and process designs for industries supplying aerospace, automotive, consumer, industrial, medical, and transportation products.

## Measurements

Data can be gathered from a wide variety of sensors or may be measured directly. Voltage, resistance, temperature, strain, frequency, velocity, acceleration, noise, vibration, harshness, and many other physical phenomena are measured. Sensor based data can be converted to engineering units during the measurement process. Many applications include digital parameters such as counters, timers, stepper motors, digital I/O, states, and pulses.

Agilent solutions can also provide a variety of control capabilities including setting alarms, stepper motor control, closed loop control with guaranteed latency, PID control, vibration control, and more. Systems may also provide a stimulus to the test device. These may be analog or digital outputs for control of switches, valves, stepper motors, shakers, hydraulic rams, or other devices.

## Data Acquisition and Control Products

### Portable, Small Channel Counts

- 34970A Data Acquisition Switch/Unit. For low cost data logging and system switching with precision 6-1/2 digit multimeter, temperature measurements with units conversion, up to 120 channels. Data logging software included. See page 154.
- 75000 Series B (E1300B/01B mainframe based) Portable/Remote Data Acquisition and Control System. VXIbus, high-speed 5-1/2 digit multimeter, temperature, strain measurements, DAC, counter/timer, digital I/O; up to 112 channels. See page 534.
- 35670A 2-4 channel FFT Analyzer. Versatile, rugged, portable spectrum analyzer. See page 535.

### High Performance, Medium Channel Counts

- 75000 Series B Portable/Remote Data Acquisition and Control System. VXIbus, high speed 5-1/2 digit multimeter with separate 16-channel multiplexers or precision 16-bit 32-channel scanning ADCs, temperature, strain measurements, DAC, counter/totalizer, digital I/O; up to 320 channels. See page 534.

### High Performance, Large Channel Counts

- 75000 Series C Data Acquisition and Control System. VXIbus, high speed scanning ADC, specialized high-speed measurement module with up to 32 PID control loops, analog signal conditioning, temperature/strain measurements with units conversion, counter/totalizer, DAC, digital I/O, pulse width, PWM, stepper motor control, up to 768 channels. See page 534.
- 3852A Data Acquisition and Control System. 8 slot Mainframe or extender based system. 40 different measurement and control modules including high-speed ADC, scanning switches, digital I/O, DAC, counter/totalizer, stepper motor control. Up to 216 channels. See page 534.
- E1432A 16 Channel 51.2 kSa/sec Digitizer + DSP.
- E1433B 8 Channel 196 kSa/sec Digitizer + DSP. Both E1432A and E1433B include transducer signal conditioning, antialias filters, 16-bit digitizer/channel and high-speed measurement computation. Control by DAC Express, Agilent VEE, Matlab, C++ or other standard programming languages. Supports 100's of channels. See page 532.
- E1563/64A 800 kSa/sec 2 or 4 Channel digitizers. High speed digitizers with up to 256 V input, up to 64 MB PC-SIMM style RAM. Ideal for fast acquisition of transient events. Common mode rejection of 113 dB, selectable 1.5, 6, 25 or 100 kHz input filters. See pages 93-96.

## More Information

Additional information on the full line of Agilent VXIbus products is available in this catalog on pages 93-96. For the full line of VXIbus products request the Agilent System Builders Source Book from your regional Agilent Call Center or visit our web site: [www.agilent.com/find/VXI](http://www.agilent.com/find/VXI)

Agilent Data Acquisition and Control Product information is available on-line. Please visit our web site: [www.agilent.com/find/data\\_acq](http://www.agilent.com/find/data_acq)

Agilent hardware is used by a large number of solution providers. These Channel Partners offer a broad variety of turn-key data acquisition solutions. See these solutions on-line:

[www.agilent.com/find/tmpartners](http://www.agilent.com/find/tmpartners)

- Broad Software Support
- Agilent VEE
- Agilent DAC Express
- Mathworks Matlab
- Visual C/C++
- Visual Basic
- Variety of Turn Key Solutions available from Channel Partners

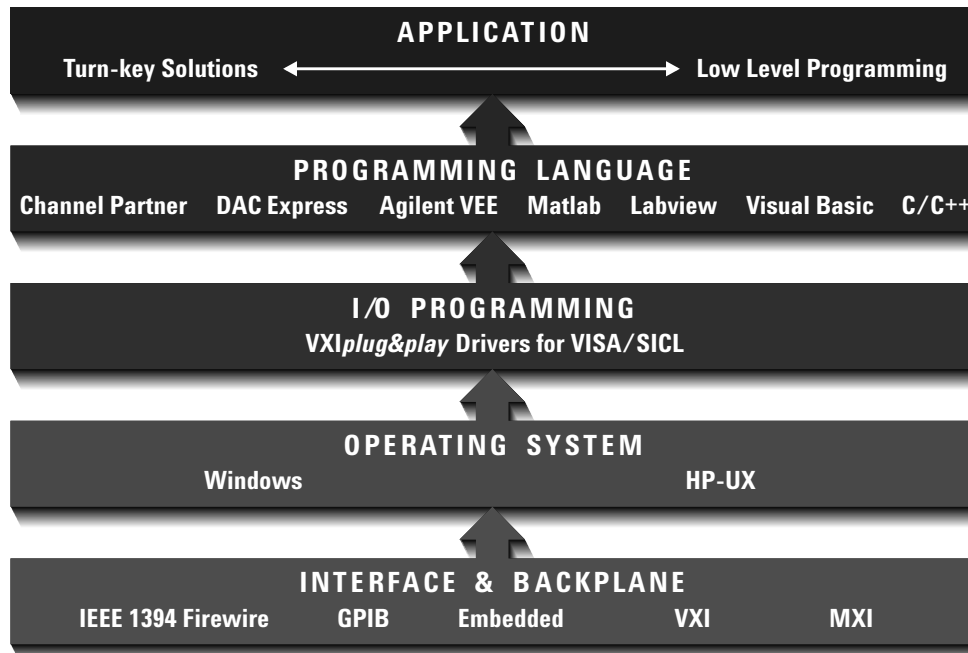

### Software Is a Compelling Part of VXI Hardware Story

Software is a key component to employing any hardware platform. Gone are the days that required months of programming effort to get a measurement system up and running. Agilent's VXI platform is a defacto standard that is used by major turn key solution providers to offer a broad range of measurement solutions. Agilent's Test & Measurement web site provides a growing list of Agilent Channel Partners that offer a wide variety of turn key measurement and data analysis solutions based upon VXI hardware.

### Agilent VEE (Visual Engineering Environment)

VEE Pro 6.0 is a powerful, leading-edge graphical programming environment for measurement and control, analysis, test systems and data acquisition applications. This new version of VEE Pro establishes a breakthrough in ease of use and power in graphical programming. Agilent Technologies collaborated with The Mathworks to embed MATLAB Script functionality and their Signal Processing Toolbox inside VEE Pro 6.0 to provide unprecedented measurement analysis capabilities.

### Control E1432A/E1433A/E1434A VXI Hardware Directly from Mathworks's Matlab

If you are one of the more than 400,000 users of Matlab and need to directly control Agilent's high performance multi-channel digitizers and source modules, Agilent is now supplying this control capability as part of its standard *plug&play* library for the E1432A, E1433B and E1434A VXI modules. The combination of Matlab 5.2's n-dimensional arrays, matrix math, color surface shaded 3-D graphics, user interface building tools and Agilent's high performance measurement hardware provide most impressive results with a minimum of programming effort. This environment is really the "measurement engineer's programming language" that quickly turns measurements into insight.

### Use C/C++ or Visual Basic Software Development Environments for Unique or Demanding Applications

Work in either Microsoft Win95/WinNT software development environments using C/C++, Visual Basic or use HP-UX C/C++, to give you a great head start in developing your custom application solutions on top of standards based Agilent VXI hardware. The VXI *plug&play* software layer allows your code to be portable across platforms. The *plug&play* layer also allows you to support multiple hardware vendors from the various software environments.

### For More Information

See Agilent's Test & Measurement Channel Partner Program web site: <http://www.agilent.com/find/tmpartners>

See Agilent's Test & Measurement Data Acquisition web site: [http://www.agilent.com/find/data\\_acq](http://www.agilent.com/find/data_acq)

E1432A  
E1433B  
E1434A  
N2216A



## VXI Measurement Platform for Mechanical and Acoustic Test

The E1433B 8-channel digitizer, E1432A 16-channel digitizer, and E1434A 4-channel arbitrary source provide both system excitation and digitization for the mechanical and acoustical tests common in the automotive and aerospace industries. The E1433B's 196-kSa/sec sample rate and onboard digital signal processing (DSP) boost total system performance while cutting system development time. The E1432A 16-channel 51.2 kSa/sec digitizer provides many of the same measurements and features as the E1433B, but at a lower sample rate and decreased cost. For system excitation, the E1434A arbitrary source provides multi-channel stimulus.

When combined with the new N2216A SCSI data disk they form a comprehensive measurement platform for mechanical, acoustical, and electrical test. Now all functions necessary for these demanding applications: digitization, excitation, and highspeed data recording are available on an industry standard VXI hardware platform.

### Minimize Complexity, Maximize Performance

The E1432A and E1433B simplify system integration by providing signal conditioning, filtering, digitization, and measurement computation, all in a single module. Built-in measurement computations such as FFTs and averaged power spectra off load work from the host computer, keeping it from becoming a computational bottleneck. The E1434A arbitrary source can playback continuous arbitrary wave forms, but also provides common test signals such as sine, random, and burst random noise.

### Software Support

Customers can develop their own custom software solutions using *VXIplug&play* drivers and common programming languages, or they can use Mathwork's Matlab or Agilent's VEE graphical programming environment. For turnkey software solutions, expect wide application support from the industry's leading third-party solution providers. Applications include rotating machinery analysis, modal analysis, acoustics, vibration control, and road simulation, as well as general-purpose multi-channel data acquisition and analysis.

### Key Literature

E1432A, E1433B and E1434A Product Overview, p/n 5966-3062E

See VXI catalog for more details and additional modules.

For the latest information on Agilent's Data Acquisition products, see our web site: [http://www.agilent.com/find/data\\_acq](http://www.agilent.com/find/data_acq)

See Agilent's Test & Measurement Channel Partner Program web site: <http://www.agilent.com/find/tmpartners>

### Ordering Information

- E1432A** 16-Channel, 51.2 kSa/sec Digitizer + DSP
- E1433B** 8-Channel, 196 kSa/sec Digitizer + DSP
- E1434A** 4-Channel, 65 kSa/sec Arbitrary Source
- N2216A** VXI/SCSI Interface Module



- Lower cost strain conditioning for large numbers of channels
- Easier connection for individual strain gages
- Versatile choice of bridge configuration and shunt calibration



E1529A

### E1529A 32 Channel Remote Strain Conditioning Unit

The E1529A is specifically designed to simplify stress and fatigue testing of large mechanical structures such as airframes and rockets. Each unit provides remote conditioning for 32 channels of strain bridge measurements in a configuration that is very easy to connect and calibrate. Additional units can be added to expand the system capability at any time.

#### Full Measurement Capability

The E1529A offers the following features:

- Low cost telecom connectors and cabling for strain gages
- Connection for external excitation to banks of eight gages
- Individual buffered output for each bridge signal
- Provision for custom shunt calibration resistors
- Up to 330 meters (1000 feet) cable lengths

#### A Modular, Reconfigurable Architecture

The E1529A provides external signal conditioning and multiplexing for a VXI-based data acquisition system. Up to two E1529A's are supported by a new Signal Conditioning Plug-on (SCP), the E1539A, that is installed on an E1422A Remote Channel DAC Unit.

The E1422A includes a 16 bit, scanning A/D, high speed DSP, and a 64,000 reading buffer in a single C-size VXI slot. Each E1422A can house up to eight SCP's which can be a mix and match of signal conditioning for strain, temperature, resistance, voltage, digital I/O, or counter functions.

For a dedicated strain measuring configuration, each E1422A can support up to 512 channels. As many as twelve E1422A's can be installed in a 13-slot C-size mainframe, thus providing a single system with 6144 channels of strain measurement.

#### Automated Calibration Saves Time

Each E1529A has an internal calibration source that is used to provide automatic input calibration. This automatic process takes only a few minutes for 512 channels. In addition, shunt calibration using an internal 50 kilohm or user supplied value is provided.

#### Key Literature

Product Overview p/n 5968-0432E  
 Technical Specifications p/n 5963-9650E  
 VXI Catalog p/n 5980-0307E

### Flexible Wiring via Terminal Blocks

Agilent provides terminal blocks standard with all low-frequency multiplexer, matrix, general-purpose switch modules, and scanning voltmeters. Several of the C-size modules have terminal blocks which incorporate Agilent's new QUIC (Quality Insertion and Connection). The QUIC terminal block provides you a convenient method of wiring to your application as shown in the accompanying illustration. A terminal block with screw or push-in spring-clamp terminals is provided as standard with QUIC-equipped VXI modules. QUIC also provides easy-in/easy-out levers and guides on the front panel to assure terminal block alignment when attaching the terminal block to the front panel of an instrument/switch module.

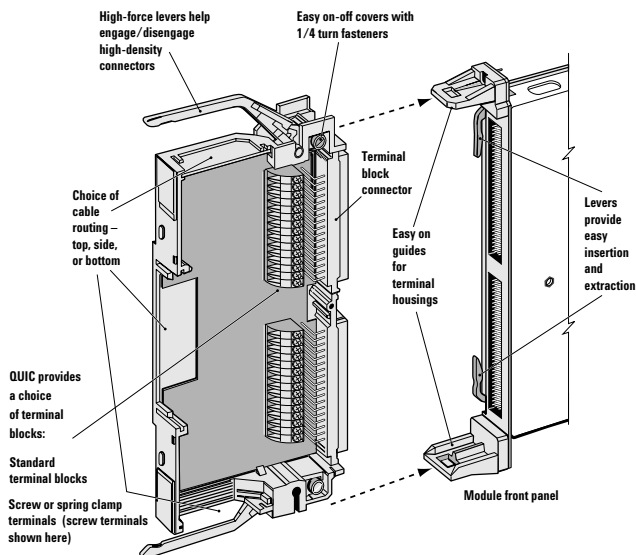

#### Rackmount Terminal Panel

- 96 terminals (32 3-wire channels)
- Built-in strain relief
- Includes pinouts and access to probe points
- System connections through 50-pin SCSI connectors
- Internal reference junction for 32 thermocouple channels

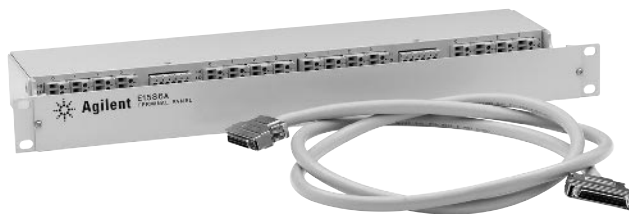

The E1586A Terminal Panel gives you maximum flexibility in configuring system wiring and interface solutions. In addition to the convenience of easy access for troubleshooting, the rackmount terminal panel gives you the flexibility you need to take advantage of money-saving wiring alternatives when system components are located at a distance from your mainframe. Within the Terminal Panel, the isothermal reference junction provides an internal reference junction for up to 32-wire thermocouple channels. The rackmount design provides easy access to the thermocouples for control and monitoring of distributed environmental temperatures, temperature control applications, and temperature control in material processing.

Optional RF filters on the terminal panel input channels filter out AC common-mode signals present in the cable connecting the terminal panel and the device under test. These filters are useful for filtering out small common mode signals below 5 Vp-p.

Connection to VXI modules with Option A3F requires either the E1588A six meter length cables or Z2220 Option 050 custom length cables.

3852A  
75000

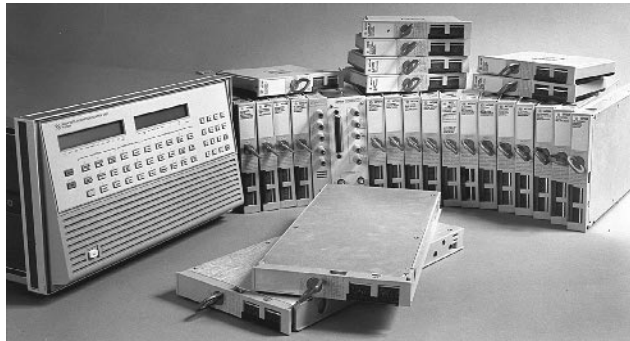

## 3852A Data Acquisition and Control System

You can easily configure a 3852A data acquisition and control system to measure physical parameters. The 3852A is set up to handle many different transducer inputs, including thermocouples, thermistors, RTDs, and strain gages, as well as measuring dc volts, currents, resistances, pulse counts, frequencies, and more. The 3852A mainframe has eight (8) slots for plug-in function modules, and has provisions for extending the mainframe (the 3853A) for large systems requiring more plug-in cards.

### High Speed and Accurate Analog in One System

Choose from two digital voltmeters to meet your measurement needs. The voltmeters can be used in the mainframe or extenders, with multiple voltmeters allowed in each mainframe.

### Versatility and Expandability

With the 3852A you can choose from a complete set of input and output plug-in modules providing a variety of measurement and output-controlling capabilities. Plug-in modules for the 3852A include a relay multiplexers, FET multiplexers, solid state relay multiplexers, analog outputs, digital inputs & outputs, a counter, and a stepper motor controller.

### Front End, Computer, and Software-System

The 3852A has built-in, 68000-based processing to increase the speed and effectiveness of the system and to collect, analyze, and respond to data. Control decisions are handled quickly using subroutines running within the mainframe (not having to communicate via GPIB to an external computer in every case). This intelligence can be used to return only the most significant data to the computer, increasing its efficiency with other tasks. The power of this front-end intelligence, in combination with an HP 9000 computer and data acquisition software, adapts easily to testing your product or characterizing your processes. Or, if you prefer, you may configure your system to run with a PC as the host computer, incorporating the Agilent VEE graphical programming language.

### Ordering Information

To order, specify an 3852A system with the appropriate software, controller, mainframe, extenders, function modules, racks, and extra terminal modules. Each component of the system is priced individually. ROM revision is in brackets. Please contact The Agilent Call Center in your region for ROM upgrades, pricing, and information.



75000 Series C VXI

## 75000 Series C VXI Data Acquisition System: High-Performance

The 75000 Series C VXI data acquisition system products provide high-performance measurement, control, and computing capabilities that are well suited for solving major equipment, vehicle, and power system and many others—design problems. This data acquisition system is based on the E1413C high-performance scanning A/D, E1415A algorithmic closed-loop controller, E1419A multifunction module, and the E6237A real-time VXI computer or HP-UX controller.

All of Agilent's VXI scanning A/D and multifunction and control modules incorporate signal conditioning plug-ons (SCPs) for configuring the module for various measurement inputs and control outputs.

## 75000 Series B VXI Data Acquisition System: Portable/Remote

The 75000 Series B DACQ is a family of portable data acquisition systems. These VXI-based solutions are suited for low to medium point-count applications where temperature, strain, pressure, flow, digital I/O, voltage, resistance, and frequency measurements are required. These systems may be used in a number of electro-mechanical applications where physical data must be collected. These include material evaluation, energy research, process characterization, facility monitoring, environmental control, or remote station monitoring and control.

The E1300B/E1301B mainframes with built-in controller, optional interfaces, and battery backup, can perform remote, unattended measurements and download data via long distance phone lines to your host computer.

### Measurement and Control VXI Modules

- E1413C 64-Channel Scanning A/D
- E1419A Multifunction Measurement and Control Module
- E1415A Algorithmic Closed Loop Controller

### High-Speed Transient Measurement Products

- E1430A 10 MSa/s 23 bit, A/D with Filter/Memory
- E1437A 20 MSa/s Digitizer with DSP
- E1563A, E1564A 800 KSa/s Digitizers

### Dynamic Measurement and Control Modules

- E1432B 51.2 kSa/s Digitizer with DSP
- E1433B 196 kSa/s Digitizer with DSP
- E1434A 65 kSa/s Arbitrary Source

### VXI Embedded Controllers (C-size)

- E6235A 200 MHz Intel Pentium
- E6237A Pentium Real-Time (Lynx OS)
- E9850A 450 MHz Intel Pentium II

- Two or four channels (optional)
- Portable-fits under an airplane seat
- 1600 line frequency resolution
- 16-bit ADC/90 dB dynamic range (typical)
- 10 MB deep transient capture (optional)

### 35670A Dynamic Signal Analyzer

The 35670A lets you make laboratory-quality measurements in the field, on an automobile test track, flying above a city, or in the narrow confines of a submarine. Small enough to fit under an airplane seat, the 35670A is a two-, or four-channel (Option AY6), FFT-based spectrum/network analyzer. The standard instrument provides spectrum, network, time-domain, and amplitude-domain measurements from virtually dc to slightly over 100 kHz. Your ability to solve problems in the field is enhanced with the optional four-channel 35670A—measure noise at multiple locations inside vehicles, make triaxial vibration measurements, or gather data from several locations along a noise transmission path.

With the 35670A, you carry all your measurement and analysis tools in one package. Octave analysis (Option 1D1) adds real-time measurements of 1/1, 1/3, or 1/12 octave spectra at frequencies up to 40 kHz. Computed order tracking (Option 1D0) allows you to view spectra as a function of orders, or to view the amplitude of multiple orders as a function of RPM. Up to 8 MB of additional memory (Option UFC) provides deep transient time capture or extra space for up to four-hundred spectra. An arbitrary source (Option 1D4) lets you test devices with real-life test signals. With Instrument BASIC (Option 1C2), you can automate measurements or customize your instrument interface. Everything you need to troubleshoot vibration and noise problems in the field is in one instrument. (You can retrofit all options—buy only the functionality you need today and add more as your needs change.)

A deep transient time capture memory can record up to four channels of data plus a tachometer signal for playback in the narrow-band FFT, octave, order, correlation, or histogram instrument modes. Pre- and post-trigger delay functions let you capture the leading edge of one-time events or eliminate transmission delay in signals.

#### Real-Time Octave Analysis to 40 kHz (ANSI S1.11-1986)

Octave analysis (Option 1D1) adds a real-time octave analyzer to your 35670A for analysis in 1/1-, 1/3-, or 1/12-octave bands. Four LEMO connectors with power for microphones are provided by the microphone adapter and power supply (Option UK4). The 1/1- and 1/3-octave band filters in the 35670A comply fully with ANSI S1.11-1986 (Order 3 Type 1-D), DIN 45651, and IEC 225-1966. An overall total power band and an A-weighted overall power band can be activated as needed. All three octave band modes and the overall power band can be A-weighted with an analog filter in full compliance with IEC 651-1979 Type 0. The overall power band can be redefined as a broadband impulse detector that complies with IEC 651-1979 Type 0. A fan-off mode eliminates instrument noise from measurements. A pink noise source allows you to evaluate electroacoustic devices.

#### View Spectra in the Order Domain (Option 1D0)

View spectra as a function of orders or track up to five orders on four channels simultaneously with computed order tracking (Option 1D0). Orders as high as 200 can be tracked. An order map can be displayed as a function of RPM or time, using the waterfall function. Waterfall markers let you view the track of any order.

Computed order tracking is ideal for troubleshooting rotating machinery. Run-up or run-down measurements can be displayed in bode or polar formats. Oscilloscope-quality orbit diagrams are another benefit. Because the data is resampled with changes in RPM, a single-loop orbit display is maintained as the shaft RPM is varied. With four channels (Option AY6), two orbits can be measured simultaneously—at both ends of a shaft, for instance. An RPM measurement readout, available in any instrument mode, aids in the interpretation of measurement data from rotating machinery.

Computed order tracking provides alias-protected measurements without expensive and cumbersome external ratio synthesizers and tracking filters. This new technique uses a digital tracking algorithm that follows rapid changes in shaft RPM without time delay and eliminates the phase noise normally associated with ratio synthesizer techniques. Accuracy is enhanced over traditional methods.



35670A

#### Swept-Sine or Broad Measurement Range (Option 1D2)

The swept-sine instrument mode expands the network analysis range of the 35670A to 130 dB. Higher noise rejection and accuracy are obtained by auto-ranging the instrument during the sweep. Automatic sweep resolution reduces measurement time without sacrificing accuracy. Alternatively, sweep resolution can be set by the user.

#### Advanced Modeling and Analysis Cut Design Time

Prototype revisions are reduced by modeling design modifications using curve fit and synthesis functions (Option 1D3). In a typical application, a model of the test device is created by curve fitting a frequency response measurement. Up to 20 poles and 20 zeros are used to describe the device; results can be output in pole/zero, pole/residue, or polynomial formats. The designer then transfers the circuit model to the synthesis function. Using synthesis, the model is modified by adding or deleting poles and zeros. The frequency response function of the modified model is then synthesized to test the design modification.

#### Automation Improves Productivity

Instrument BASIC (Option 1C2) replaces the external computer in small test systems. Like the computer, it can be used to automate measurements, create a custom user interface, synthesize new information from raw data, or control other instruments and peripherals. An optional external keyboard plugs into the rear panel. The 35670A provides direct control of external disks, plotters, and printers via GPIB RS-232, or parallel interfaces, and is fully programmable via the GPIB.

#### Option 100 software bundle

Bundles options 1D0 through 1D4 and UFC. 35% discount over the same options sold separately.

#### Key Literature

35670A RotoDynamics Measurement, p/n 5966-0518E  
 35670A Technical Data Sheet, p/n 5966-3064E  
 35670A Product Overview, p/n 5966-3063E  
 DSA Accessory Catalog, p/n 5966-2340E  
 Standard Data Format p/n 5091-2945E

For more information, visit our website:

<http://www.agilent.com/tmo/datasheets/English/35670A.html>

#### Ordering Information

##### 35670A Dynamic Signal Analyzer

- Opt AY6 Add 2 Input Channels
- Opt 1D0 Computed Order Tracking Measurements
- Opt 1D1 Real-Time Octave Measurements
- Opt UK4 Microphone Adaptor and Power Supply
- Opt 1D2 Swept-Sine Measurements
- Opt 1D3 Curve Fit/Synthesis
- Opt 1D4 Arbitrary Waveform Source
- Opt 1C2 Instrument BASIC
- Opt AN2 Add 4 MB Memory
- Opt UFC Add 8 MB RAM
- Opt 100 Software Bundle
- Opt UFF Add 1 MB Nonvolatile RAM

##### Accessories

- 35250A DC Power Cable (3 m)
- 35251A DC Power Cable w/Cigarette Lighter Adapter

**FFT Dynamic Signal Analyzers**

DSA Accessory Catalog  
[5966-2340E](#)  
35639A Demo Disk Set-Up Instructions  
[5963-1833E](#)  
35639A Data Viewer Demo Disk  
[5963-1834E](#)  
35639A Data Viewer Product Overview  
[5962-9499E](#)  
Internet Advisor for Troubleshooting High-Speed  
LAN, WAN and ATM Internetworks J2300C  
[5968-0863E](#)  
E1562D/E/F Technical Specifications  
[5965-6938E](#)  
E35670A Dynamic Signal Advisor  
[5966-3063E](#)

**Data Acquisition Systems**

34790A Data Acquisition/Switch Unit,  
Product Overview  
[5965-5290EN/EUS/EE](#)  
E1529A Remote Strain Conditioning Unit,  
Product Overview  
[5968-0432E](#)  
E1529A Remote Strain Conditioning Unit,  
Technical Specifications  
[5963-9650E](#)  
VXI Catalog  
[5980-0307E](#)  
  
(PN E1415A) E1415A Algorithmic Closed  
Loop Controller  
[5965-3311E](#)  
(PN) E1413A/B/C, E1313A, and E1415A  
Recommended Wiring and Reduction  
Techniques  
[5965-1635E](#)



Laser Interferometers/ Encoders & Laser-based Calibration Systems	538
Additional Literature	544

10897B

- PC-compatible and VMEbus electronics
- Resolutions to 0.3 nm, data rates to 10 MHz
- PC servo-axis board for closed-loop positioning
- Multiaxis measurements for greater control
- Wavelength-of-light compensation
- Remote sensing with fiber-optic receivers

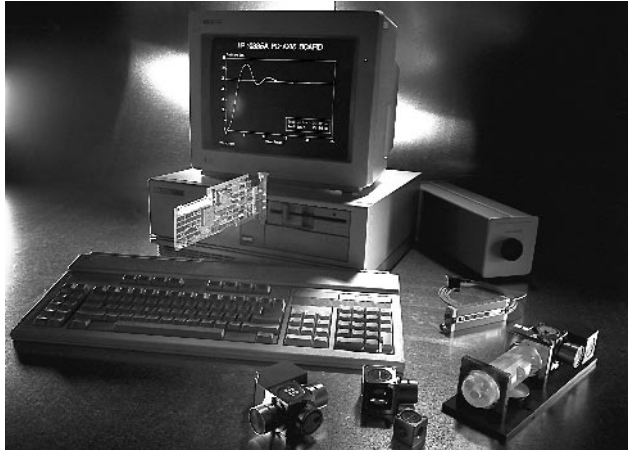

PC-compatible laser interferometer electronics provide open- or closed-loop positioning and speed integration into the lowest-cost industry-standard backplane.

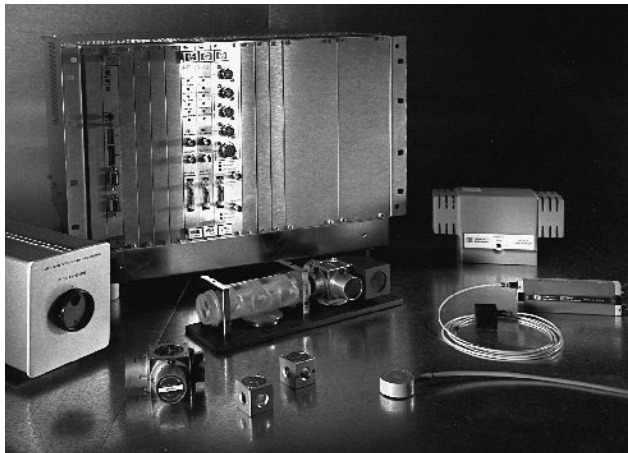

The 10897B High Resolution Laser Axis Board for VMEbus provides the highest position resolution available from Agilent and allows easy, cost-effective integration into this popular, 32-bit industry-standard backplane.

### Precision Positioning Systems

Laser interferometer precision positioning systems—composed of electronic and optical components—provide very precise position or distance information for dimensional measurements and motion control. When built into manufacturing and inspection equipment, a laser interferometer system reports the position or controls the motion of a product platform with more accuracy than any other method.

Precision laser positioning systems improve product quality and reliability, increase manufacturing consistency for increased production yields, and allow the production of precision products that would otherwise be impossible to manufacture. Laser interferometer positioning systems are vital in many applications:

- Integrated-circuit fabrication, inspection, and repair
- Manufacture of high-capacity disk drives
- Precision machine tools
- Manufacture or calibration of other measurement scales
- Mechanical parts inspection/measurement
- Custom test and measurement
- Precise plotting
- Mechanical vibration analysis
- Antenna testing

### System Components

Agilent precision positioning systems combine Michelson interferometry with a two-frequency HeNe laser. Agilent's patented two-frequency design provides greater stability and reduced noise sensitivity, and extends the measurement range—up to 40 m (130 ft), or 80 m (260 ft) in certain circumstances. Three subsystems make up a laser interferometer system:

**Laser:** Supplies a monochromatic light source (or beam)

**Optics:** Directs the beam and generates the interference pattern

**Electronics:** Detects and counts the light and dark interference fringes, processes the data, and outputs distance information

Agilent offers the components needed to configure laser interferometer positioning systems for a broad range of applications and other requirements. All systems support the same laser sources, and optics, and are primarily differentiated by the receivers and electronics.

### Interferometer Electronics

Agilent interferometer electronics offer a choice of backplane (interfacing characteristics), output formats, and environmental compensation options. Table 1 on page 540 summarizes the Agilent products based on these differentiators.

The Agilent product line offers interferometer electronics tailored for a variety of customer needs. For interfacing to industry-standard backplanes, the VMEbus provides a high-performance alternative and PC products provide the lowest-cost solution. Both are popular industry standards and offer system configuration flexibility.

Each of the electronics alternatives supports the complete range of lasers and optics. In addition, the 10780C receiver, 10780F remote receiver, E1708A remote dynamic receiver, and E1709A high sensitivity dynamic receiver work with all electronics.



The 10737L and 10737R Compact Three-Axis Interferometers improve positioning accuracy of lower-cost equipment too compact to use the 10735A or 10736A.

### Optics

The optics tailor each interferometer system for the physical layout and measurement requirements of each application.

**10702A Linear Interferometer:** The basic optic for linear measurements

**10706A/B Plane-Mirror Interferometers:** Commonly used with multi-axis stages

**10716A High-Resolution Interferometer:** A plane-mirror interferometer with twice the resolution of the 10706A/B

**10715A Differential Interferometer:** A plane-mirror interferometer for differential measurements

**10705A Single-Beam Interferometer:** Physically smaller for confined spaces or low-mass, non-contact measurements

**10719A, 10721A One- and Two-Axis Differential Interferometers:**

For optimized accuracy and repeatability with IC fabrication equipment; the position of the wafer stage is directly referenced to the optics column

**10735A, 10736A Three-Axis Interferometers:** Can be used in pairs to make 5 precise measurements (x, y, pitch, roll, and yaw) simultaneously for IC fabrication

**10737L/R Compact Three-Axis Interferometers:** Multiaxis measurements for precise control of smaller, lower-cost equipment

See the table for a summary of Agilent reflector products and the configurations supported with Agilent optics.

### Laser Heads

Four laser heads are available for Agilent interferometer systems: the 5517A, 5517B (500-mm/second axis velocity for linear optics), 5517C (700 mm/second for linear optics), and 5517D (1000 mm/second for linear optics).

The total accuracy of an interferometer system is the sum of the errors from the laser head, the optics, and the effects of the environment. All Agilent laser heads have a vacuum wavelength accuracy of  $\pm 0.1$  ppm. Option UK6, an NIST-traceable wavelength calibration service, is available. With this calibration, a laser's wavelength accuracy becomes  $\pm 0.02$  ppm. Agilent laser heads over the last 25 years have a demonstrated mean time between failure of greater than 50,000 hours.

### Improving Accuracy and Repeatability

Maximum accuracy and repeatability require compensation for environmental conditions. The wavelength of light in air varies with the air's refractive index, which is a function of air temperature, pressure, and composition. In addition to the wavelength-of-light effects, errors can result from thermal expansion of the workpiece. To take full advantage of Agilent's high-wavelength stability, the 10717A Wavelength Tracker compensates for changes in the air's refractive index. The 10896B, with wavelength-of-light compensation and material temperature measurement, increases accuracy and repeatability for VMEbus systems, and the 10886A provides these functions for PC-compatible systems. Product Note 5527A/B-2 (p/n 5952-7973) describes in detail how to achieve maximum accuracy and repeatability.

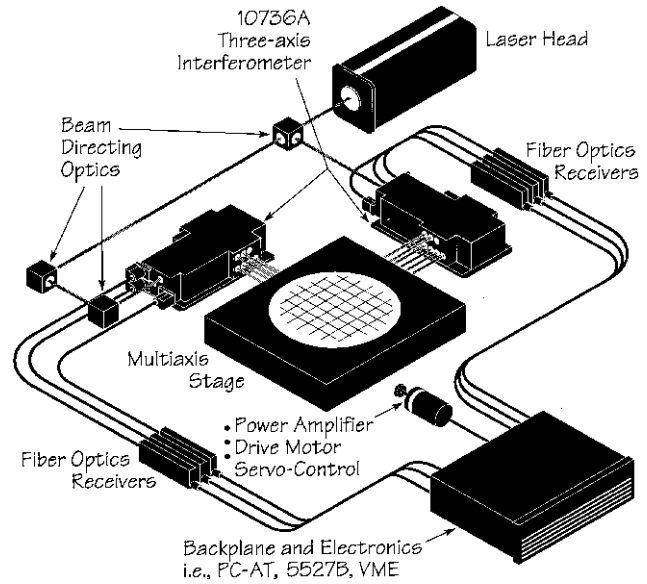

1070x A/B  
1071x A  
1072x A  
1073x L/R

The 10735A and 10736A Three-Axis Interferometers offer greater accuracy for microlithography and other applications that require up to five degrees of freedom.

### Reflectors and Interferometers: Supported Combinations

Interferometers	Reflectors/Mirrors			
	10703A, 10713B	10704A, 10713C, D	10724A	Custom Mirrors
10702A	•			
10705A		•		
10706A/B			•	•
10716A			•	•
10715A			•	•
10719A, 10721A				•
10735A, 10736A				•
10737L/R			•	•

### Key Literature

To configure and order an Agilent laser interferometer positioning system, please request the appropriate data sheets and ordering information from the Agilent Technologies Call Center in your region:

Introduction to Laser Systems Brochure, p/n 5091-2507E  
Laser Head and Optics Technical Data Sheet, p/n 5964-6190E  
PC Compatible Technical Data Sheet, p/n 5091-8435E  
VMEbus Technical Data Sheet, p/n 5965-1569E  
Systems Ordering Information, p/n 5964-3700E

See the next page for information on laser system electronics.

5507B  
108xx Series  
109xx Series

**Table 1: Key Characteristics of Agilent Laser Interferometer Electronics**

System	Backplane	Electronics	Output formats	Other differentiators
<b>PC Compatible</b>	ISA (PC/AT)	10885A	32-bit digital (hardware output and backplane output)	Lowest-cost, most-popular, industry-standard backplane  Servo-axis board Fast system development Part of 5529A calibration system Programmable version of 10887B Complete environmental compensation
		10889B	Motor drive (in $\pm 10$ Vdc)	
		10887B	32-bit digital	
		10887P	32-bit digital	
		10886A	PC compensation board	
<b>VMEbus</b>	VMEbus	P 10895A	32-bit digital (hardware output and backplane output)	High-performance, robust, industry-standard 32-bit backplane  High resolution and data rate Fast system development Dual-axis, high resolution, slew rate and data rate  Complete environmental compensation
		10897B	36-bit digital (hardware output and backplane output)	
		10898A	36-bit digital (hardware output and backplane output)	
		10896B	VME compensation board	

### PC-Based Laser Interferometer Positioning System

The 10889B PC servo-axis board is a programmable, digital servo with built-in motion control algorithms for closed-loop positioning that is compatible with the most popular PC backplane. Output is a  $\pm 10$  V analog motor drive signal updated at 20 kHz. A trace function speeds and simplifies servo-loop characterization and tuning. The 10885A PC axis board provides a 32-bit digital, real-time position output via hardware, and position can also be read over the backplane. The 10886A PC compensation board increases accuracy and repeatability of systems using either the 10889B or 10885A by compensating for environmental conditions using Agilent environmental sensors. Combining the high performance of Agilent laser interferometers with the most popular, lowest-priced, industry-standard backplane speeds system development and reduces system costs.

### VMEbus Laser Interferometer Positioning System

The 10897B and 10898A high-resolution laser axis boards provide high position resolution (up to 0.3 nm) at a 10 MHz rate for the most demanding applications. Position data is output in 36-bit format for very high performance closed-loop positioning systems. The 10895A laser axis board provides output in 32-bit format for typical applications. Both boards provide a hardware position output and also output position over the VMEbus backplane. The 10896B compensation board increases the accuracy and repeatability of systems using either the 10897B or 10895A by compensating for environmental conditions using Agilent or custom environmental sensors. All Agilent laser electronics for VMEbus are compatible with VME Rev. C.1 providing easy, cost-effective integration into VMEbus.

### System Specifications

	PC Compatible	VMEbus
<b>Accuracy</b>		
Vacuum	0.1 ppm	0.1 ppm
Vacuum with MIL-STD-45662A	0.02 ppm	0.02 ppm
<b>Maximum resolution</b>		
Linear optics	5 nm	1.2 nm
Plane mirror optics	2.5 nm	0.6 nm
High-res. optics	1.2 nm	0.3 nm
<b>Maximum axis velocity</b>		
Linear optics	1000 mm/s	1000 mm/s
Plane mirror optics	500 mm/s	500 mm/s
High-res. optics	250 mm/s	250 mm/s
<b>Maximum optical range</b>	40 m	40 m
<b>Maximum hardware data output rates</b>		
Position/position error	3.0 MHz	10.0 MHz
A-Quad-B (transition rate)	N/A	N/A
Up-down pulse	N/A	N/A
Motor-drive	20 kHz	N/A
<b>Environmental compensation</b>	Yes	Yes

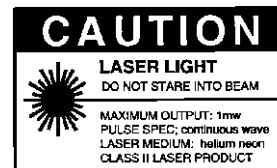



- Calibration of machine tools, CMMs, pick and place machines, robots, and machines with precision movement
- Comprehensive calibration
- Flexible triggering and parameter setting
- Minimum machine downtime with easy control through MS-Windows
- Graphical output provides conformance to seven international standards
- Complete localization in eight languages
- Customized compensation table enables improved performance



### 5529A Dynamic Calibrator for Flexible, Comprehensive Calibration

The 5529A dynamic calibrator is a high-performance calibration tool for most equipment with precision movement. This calibrator minimizes downtime and enables conformance to international standards with its powerful measurement capability. The 5529A is a laser-based machine tool calibration system consisting of a laser head, optics, PC-based electronics, and Microsoft Windows-based software that operates in an IBM-PC-style (ISA bus) computer.

#### Comprehensive Measurements

- Linear
- Angular
- Straightness
- Squareness
- Way straightness
- Parallelism
- Flatness
- Timebase
- Ballbar
- Diagonal
- Thermal drift
- 2-axis
- Rotary table

#### Flexible Triggering

- Manual
- Automatic
- A-Quad-B

#### Flexible Parameters

- Environmental compensation
- English/metric units
- 0 to 10 seconds averaging
- Measurement target lists
- Upload/Download CNC compensation tables

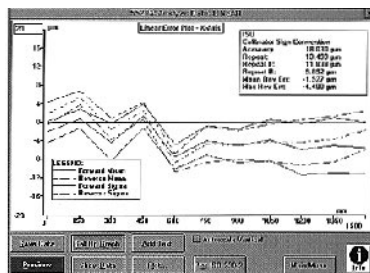

Linear Plot Using ISO 230-2

#### Conform to Seven International Standards

Today's world market requires many manufacturers to conform with a specific international standard. The 5529A provides graphical output that shows your machines' conformance with seven international standards:

- ISO 230-2
- NMTBA
- ANSI B5.54
- BSI
- VDI
- JIS
- GB 10931-89

#### Available in Eight Languages

Complete documentation, control, and on-line help is available in eight languages:

- English
- French
- Spanish
- German
- Italian
- Japanese
- Chinese (PRC)
- Chinese (ROC)

#### Brief Specifications

**Data Rate:** Up to 33 kHz

##### Linear

**Accuracy (range):**  $\pm 0.02$  ppm to  $\pm 3.0$  ppm

**Resolution:** Down to 1 nm

**Range:** Up to 80 meters

##### Angular

**Resolution:** Down to 0.005 arc seconds

**Range:**  $\pm 20^\circ$

#### Key Literature

- 5529A Brochure, p/n 5968-0111E
- 5529A Price List, p/n 5966-3285EUS
- 5529A Spec Sheet, p/n 5964-9307E

#### Ordering Information

5529A Dynamic Calibrator



55292A

### 55292A USB Expansion Module

- Designed especially for the 5529A dynamic calibrator
- Universal serial bus for use with 5529A laser measuring system
- Host for one 10887B calibration board and one 10886A compensation board in each module
- 5 modules can be used simultaneously with addition of a USB hub
- Allows use of small, lightweight laptop computers using Windows 98 or Windows 2000
- Extreme portability
- Includes new metrology software meeting the latest known revisions of 7 international machine-tool standards

#### Universal Serial Bus Offers

Faster speed, Windows 2000 compatibility and ease of use, no more IRQ conflicts.

#### Minimum Requirements:

- IBM compatible computer with Windows 98 or Windows 2000 installed
- 64MB ram, CD-ROM drive
- 1 internal USB port

Note: Add-on adapters are not supported.

All 10887A and 10886A boards must be reset to factory defaults: 10887A to addr 512, IRQ5 and 10886A to addr 288

**Shipping weight:** 2.1 kg (4.62 lb)

**Envelope:** 387 mm H x 184 mm W x 127 mm D (15.42 in x 7.36 in x 5.08 in)

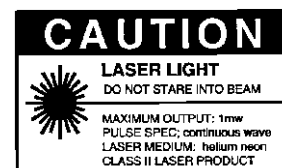

E1710A  
E1721A

- Data Storage: Servo Writing, Spinstands, HGA Testers
- Dimensional metrology

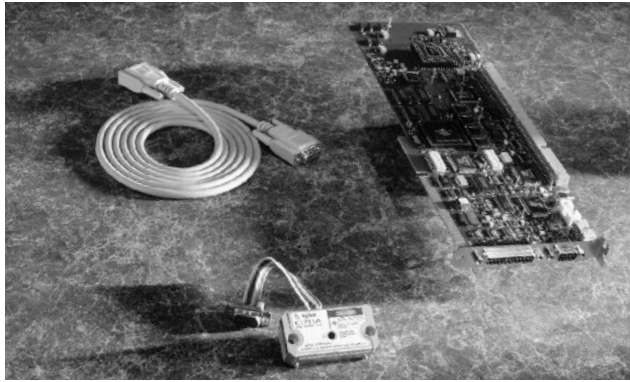

Angular Encoder System (E1710A)

### E1710A Encoder System

The E1710A Angular Encoder System is a PC-compatible set of opto-mechanical and electronic components. It provides ultra-high resolution (16 nanoradians angular or 0.6 nm linear) measurements and servo-controlled positioning for use in dimensional metrology and motion control. It is a compact, integrated solution for precisely-controlled angular positioning used in writing servotacks in the data storage industry. Individual components of the E1710A systems are available if you wish to integrate specific E1710A functions into systems of your own design. The E1710A is available with the E1710A Option 001 Master Arm Assembly. This combines a power amplifier, motor, arm and mechanical pushpin (E1710A Option 002) in an easy-to-use, integrated package.

### Increase Storage Densities Through Greater Track-to-Track Accuracy (10 nm)

The Encoder Systems are immune to turbulence created by spinning disks as well as from other changing conditions of the servotrack writing environment. This translates into superior track-to-track accuracy in measuring and controlling the drive arm.

### Simplify Servo Designing Tasks with Electronics

Why spend valuable resources designing a custom servo capability when you can buy a cost-effective, easy-to-use electronics board from a leader in electronics for servotrack writing applications?

### Lower Your System Cost

Agilent Encoder Systems are designed for cost efficiency. They have few components, and there is no need for alignment if you purchase a factory-assembled and fully-tested system, including the master arm assembly. Their rugged construction provides long-term reliable performance.

### System Components

The E1710A Encoder System consists of the components described below:

#### E1711A Sensor Head

The sensor head uses an infrared laser diode and interferometric technique to read the displacement of the scale relative to the sensor head. The lines on the scale are imaged onto a detector, which at all times views and averages more than 10 markings. This results in highly linear measurements with relatively high immunity to dirt on the scale. The base of the sensor head has precisely machined holes for locating pins to facilitate accurate mounting in user-supplied hardware.



#### E1712A Scale (specify by option code)

The standard linear scale (Option 011) is 75 mm long, on a glass substrate 1.5 mm thick. The standard angular scale (Option 038) is designed to be mounted so that the encoder markings are centered at a radius of 38.2 mm measured from the axis of rotation. Registration marks are provided on the angular encoder to assist in accurately positioning it at the design radius. Other linear and angular scales are available to fit various measurement needs.

#### E1713A Scale Servo Axis Board

This new 8-bit PC/AT-compatible board processes the signals from the sensor head to provide a 32-bit position word at a dedicated connector and on the ISA bus. The position word can be used to control either the onboard servo or a user-provided servo. The onboard servo runs a proportional-integral-differential (PID) or infinite-impulse-response (IIR) equation for a single measurement axis, and generates a  $\pm 10$ -volt output signal to either the servo amplifier and Voice Coil Motor (VCM) of the E1714A Master Arm Assembly, or a user-provided servo-amplifier motor. The servo axis board also has a provision for adding a 16-bit value to the control loop for systems using multiple inputs. The board comes with the following software: Tune Program, Demo Program, and a library of functions (ANSI C source code). The user's manual (E1710A Option 101) includes the procedure for setting the PID coefficients. (The firmware and software used for servo functions are based on those used with the 10889B Servo Axis Board.)



Non-Contact Push Pin Sensor, E1721A

### E1721A Non-Contact Push Pin Sensor

The E1721A Non-contact Push Pin (NCP) Sensor is an optical replacement for the mechanical push pin. Because no physical contact is being made with the head stack assembly (HSA), the NCPP offers the advantage of not introducing any new resonances to, or changing existing resonances in, the servotrack writing process. Furthermore, stiction errors are eliminated.

The sensor head of the NCPP is attached to the servotrack writer's (STW's) master arm. It contains a laser diode, optics, and a detector. The laser diode's focused beam reflects off a target feature on the E-block or suspension of the HSA. The image formed by the target feature is itself imaged onto the detector. The detector signals are then electronically processed to provide an error signal, which is proportional to the relative displacement between the master arm and the HSA. This signal is used to servo-control the position of the HSA to the position of the master arm with the E1723A DSP Servo-Axis Board or customer-supplied electronics.

The E1721A is a Class II laser device with continuous power, single mode laser output, with a wavelength of 670 nm typical and an output power of 1mW max.



The following options are available with the E1721A Non-contact Push Pin Sensor:

**E1721A Opt. 001:** Add NCPP Cable (connects pre-amp module to E1723A DSP Servo-Axis Board)

**E1721A Opt. 002:** Add RS-232C cable 3m, 9M D to 9F D (connects 9F D connector to Customer-supplied electronics)

**E1721A Opt. 101:** Operating Manual (English version)

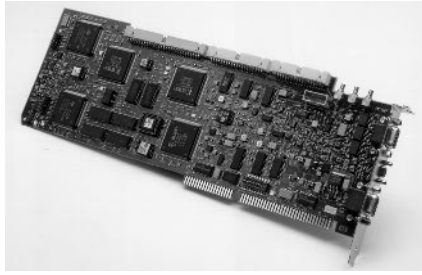

### E1723A DSP Servo-Axis Board

The E1723A DSP Servo-Axis Board is a user-programmable, two-axis servo card with custom input circuitry for each axis. The board can be used with one axis controlling the E1710A Encoder System (i.e., E1711A Sensor Head), and one axis controlling the E1721A Non-contact Push Pin (NCP) Sensor.

You may choose to:

- Write your own low-level programming code (using program development information provided by Agilent and Texas Instruments) to control the DSP to implement specialized control systems, or
- Use the supplied software to download coefficients for running the built-in PID equations (with feedforward) or IIR (to 8th order) along with factors for notch and low-pass filters on each axis.

#### Axis #1

This axis accepts its input from the E1711A Encoder sensor head. In a typical system, the E1711A monitors the position of a linear or angular scale, and outputs an analog voltage used to control stage position.

#### Axis #2

This axis accepts its input from the E1721A Non-contact Push Pin (NCP) sensor head. In the typical application, the NCP sensor head monitors a target feature located on the stage to be controlled. The sensor head detects optically whether the target is to the right, left, or centered relative to the sensor head. A signal from the sensor is processed through the servo equation to produce a voltage used to control the stage carrying the target feature to keep it in a fixed position relative to the sensor head ("nulling servo").

#### Mechanical Dimensions

Standard full length AT-size board which supports 16-bit data bus transfers. The standard E1723A ships with 128k onboard memory.

The following options are available with the E1723A DSP Servo-Axis Board:

**E1723A Opt. 001:** Add NCPP cable

**E1723A Opt. 002:** Deep Memory (512k bytes)

**E1723A Opt. 101:** Add (English version) Operating Manual and System Software

#### E1710A/20A Encoder Systems (Sensor Head, Scale and Servo Board)

	<b>E1710A<sup>1</sup> Angular Encoder</b>
<b>Repeatability</b>	0.05 $\mu$ rad
<b>System resolution (LSB)</b>	16 nanoradians (8 nanoradians LSB)
<b>Track-to-track accuracy</b>	$\leq 0.25 \mu$ rad (250 $\mu$ rad span)
<b>Long range accuracy</b>	$\leq 0.19\%$ <sup>3</sup> (40 degree sweep)
<b>Range</b>	$\pm 20$ degree <sup>4</sup>
<b>Sensor head dimensions</b>	61 mm x 33 mm x 17 mm
<b>Scale dimensions</b>	30 mm x 7 mm x 1.5 mm <sup>4</sup>
<b>Operating temperature range</b>	15° C to 40° C
<b>Velocity</b>	22.2 radians/s
<b>Power requirements<sup>2</sup> (via E1713A)</b>	+5 Vdc @ 2 amps +12 Vdc @ 1.2 amps -12 Vdc @ 0.09 amp (with E1714A)

<sup>1</sup> For angular system, scale radius = 38.2 mm, other radii available

<sup>2</sup> Power for E1711A Sensor Head and E1713A Servo Axis Card

<sup>3</sup> 0.19% = 0.0004% (scale tolerance) + mounting eccentricity

<sup>4</sup> With standard scale. Other sizes available. Contact factory regarding your needs.

#### E1713A Scale Servo Axis Board

**Motor Drive Output:**  $\pm 10$  volts with 0.3 mV resolution, updated at the sample rate. Programmable limit centered on zero volts.

**Sample Rate:** Up to 20 kHz (depends on equation used)

**Hardware Position Output:** 32-bit, updated at 400 kHz

**Servo Equations:** PID with feedforward or up to third order IIR

**Data Age:** 6.56  $\mu$ sec (top connector)

**Interface:** Full size PC-compatible card. 8-bit ISA bus interface.

#### E1714A Master Arm Assembly

**Track-to-Track Step and Settle Time:**

5 msec typical for a 65  $\mu$ rad step (2.5  $\mu$ m step at R = 38.2 mm)

**Servo Bandwidth:** 200 Hz

**Angular Range:**  $\pm 20^\circ$

**Mechanical Pushpin Radial Location Range:** 15–55 mm

**Operating Temperature:** 0° C to 40° C

**Torque:** 0–6V 0.0093 N–m/V; 6–10V 0.056 N–m

**Power Requirements:** +12V @ 1 amp

Note: When ordered with the E1710A system, the master arm is ordered as E1710A Option 001.

#### E1721A Non-Contact Push Pin (NCP) Sensor Specifications

**Noise Equivalent Displacement:**  $\leq 1$  nm rms (B/W = 3.5 kHz)

**Error Slope Around Null:** 0.18 mV/nm nominal

**Operating Temperature Range:** 15–40° C

**NCP Head Dimensions:** 21.3 mm H x 17.5 mm W x 8.0 mm D

(.852 in x .7 in x .32 in)

**Pre-amp Module Dimensions:** 48 mm H x 31.8 mm W x 13.7 mm D

(1.92 in x 1.272 in x .548 in)

**Mass of Sensor Head:** 6 g nominal

**Standoff Distance, concave target:** 14.0 mm nominal (window to target feature); (24.75 mm  $\pm$  0.25 mm from center of alignment holes to bottom of target feature)

**Laser Output:** 670 nm typical, single mode, continuous power, 1 mW max., Class II laser

**First Mechanical Resonance:**  $\geq 4$  kHz

**Capture Range** (before initialization):  $\geq 20 \mu$ m

**Target Feature:** The target is a reflective, concave, cylindrical feature with radius of 0.5 mm  $\pm$  0.1 mm

**Cable and Connectors:** The sensor head is connected to the remote pre-amp via a printed circuit flex cable. The remote pre-amp is terminated in a standard 9-pin D connector.

**Mounting Method:** Two locating holes are provided as well as tapped holes for M3 x 0.5 screws (clearance holes for M2 screws).

#### E1723A DSP Servo-Axis Board Specifications and Features

**Axis #1 Resolution:** 0.6 nm

**Axis #2 Resolution:**  $< 2$  nm

**Sample Rate:** 50 kHz (both axes running, with each axis running 4 biquads to process the position error signal, and another 4 biquads that process the position error plus feed forward value)

**DSP Used:** Texas Instruments TMS320C32-60; DSP code customer programmable, and can be stored in flash memory

**Input/Output:** Auxiliary digital input port (16 bit) that can be directed to either servo; Auxiliary digital output port (16 bit) that can be directed to either servo; Auxiliary analog input and output port that can be connected to either servo; Output port (analog) for motor drive ( $\pm 10$  V output, 0.305 mV resolution) on each axis

#### Ordering Information

**E1710A** Angular Encoder System

(38.2 mm radius scale is standard)

**E1711A** Sensor Head (Sensor Head Cable included)

**E1712A** Scale (order with an option code)

**E1713A** Scale Servo Axis Board

**E1714A** Master Arm Assembly (with standard

38.2 mm scale included on arm)

**E1721A** Non-contact Push Pin (NCP) Sensor

**E1723A** DSP Servo-Axis Board

For available options, contact your local Agilent Call Center.

5529A/55291A Verify Machine Performance  
with the World Standard for Laser-based  
Metrology  
[5968-0111E](#)

E1710A/E1720A Encoder Systems  
[5966-4875E](#)

E1710A/E1720A Push the Limits on Disk  
Drive Track Density with the Highest  
Available Resolution  
[5965-6899E](#)

E 1721A Non-contact Push Pin and  
Pre-Amp Module  
[5966-1959E](#)

E1723A DSP Servo-Axis Board  
[5966-1960E](#)

5529A Dynamic Calibrator Technical Data  
[5964-9307E](#)

10895A/96A/97A High Performance Laser  
Interferometer Positioning Systems for  
VMEbus  
[5965-1569E](#)

Choose from a Large Selection of Optical  
Components for System Design Flexibility  
[5964-6190E](#)



Cabinets & Cabinet Accessories 546

Operating & Transit Cases 552

Cables & Adapters 554

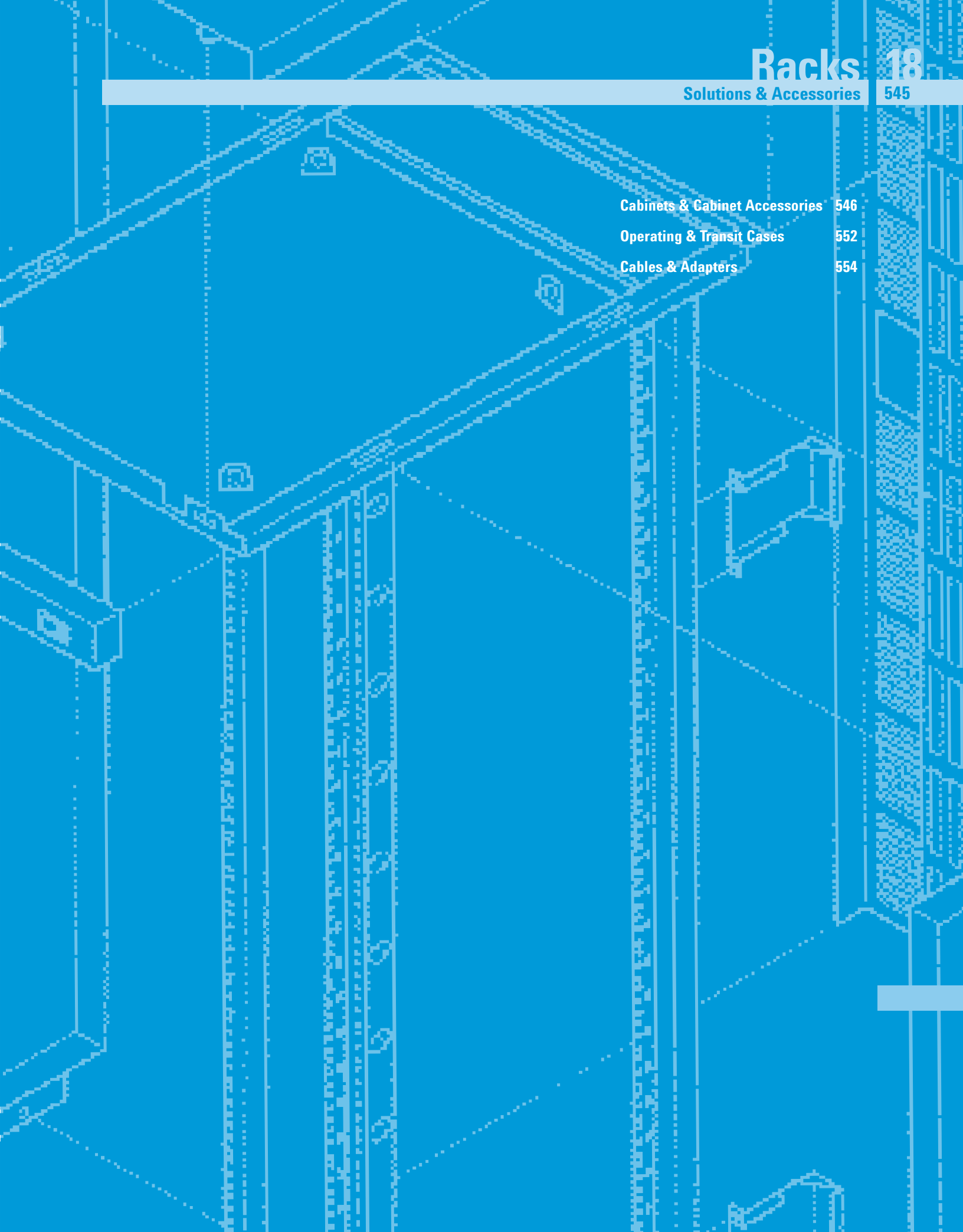



Standard rack cabinets

### Rack Solution for Agilent Systems

Agilent Technologies offers 19-inch EIA rack cabinets tailored to meet the needs of its test and measurement instrumentation customers. Rack mounting is fast and easy with unique design features. A selection of options and accessories provides flexibility to meet the vast majority of racking applications.

Standard rack includes:

- Vented, lockable rear door
- Easily removable side panels
- Vented top
- Solid base
- Leveling screws
- Retractable anti-tip foot
- 4 concealed lifting hooks
- One System II rail kit (instruments mountable in both front and rear columns)
- 3-inch heavy duty casters
- Attractive color
- Rack shipped assembled (shipping cost included in price)

### Agilent Rack Value

Agilent racks have been designed and engineered to save time and money for our customers.

- Package design: Designed for easy unloading from the pallet.
- Pallet re-use: The pallet has been tested with up to 1000 pounds of equipment in the rack and can be used to ship an integrated system to your end-user customer saving you time and money.
- Fully assembled rack: Customers receive Agilent racks fully assembled and ready for equipment installation saving time and money.
- Unique column and rail design: Equipment installation time is cut in half because of Agilent's unique column and support rail design. Our rail hooks and special cutouts in the columns, spaced at (Electronics Industry Association) intervals, ensure instruments are easily mounted in the right place the first time.

### Enhance Your Instrument Investment

Agilent racks are specifically designed for Agilent's test and measurement equipment, virtually ensuring a perfect fit. Designed for today's competitive environment, four heights are offered to accommodate any system: 1.1 m, 1.3 m, 1.6 m, and 2.0 m. All racks are deep enough to hold Agilent instruments of varying sizes. Agilent racks will also accommodate non-Agilent equipment, making them suitable for the customer of a mixed instrument environment.

### Load a Rack in Less Time

The design of Agilent support rails can halve the time required to install equipment in a rack. The rails hang on discrete slots in the vertical mounting columns, which correspond to each EIA unit in the rack. Vertical adjustment between instruments is minimized by selecting the proper rail. The system—specifically designed to minimize the time required to install Agilent instrumentation and computers—can be used with other equipment as well.

### Rack Systems Fast and Easily

Racks are shipped pre-assembled, ready for immediate configuration. No time is lost assembling racks or tracking down missing parts.

More than just a way of storing instruments, the racks reflect Agilent's reputation for quality and design. A sturdy frame provides structural integrity, which allows lightweight, easy-to-remove side panels for easy installation and ready access to equipment and cables. Rails are placed into keyed slots in the vertical columns for quick and accurate positioning.

### Use Vertical Space Efficiently

Vertical space within a rack is measured in industry-standard EIA units, where 1 EIA unit = 44.5 mm (1.75 in). Equipment height is also specified in EIA units.

System configuration is made easier by counting EIA units from the base of the rack to ensure seamless fit of instrument and rail. Other racks offer support rails that can be continuously adjusted vertically within a rack, which offers infinite adjustability, but can increase installation time.

### Manage Power Requirements

A power management system is available by ordering an optional power distribution unit (PDU) that is vertically mounted behind the rack rear column and supplies power to the cabinet. It can be controlled by a single, illuminated master switch located on the front of the rack.

### Protect from Heat Buildup

System-generated heat is removed by natural convection through a ventilation path incorporated in the rack's roof. For greater heat dissipation, an optional, easy-to-install, top-mounted extractor fan is available.

### Secure Instruments During Test

Both the rear door and the optional Plexiglas front door can be locked to secure against disruption of tests or unauthorized removal of system components. The symmetrical rear door design allows it to be mounted for opening to either left or right—useful for multi-bay configurations.

### Move Racks Easily

Each rack is provided with four 3-inch diameter, smooth-rolling, heavy-duty casters to facilitate moving racks over short distances. Four lifting hooks conveniently concealed in the top of the rack allow for transport, even when fully loaded. Each hook can support 227 kg (500 lb) to easily handle the maximum recommended gross weight for a loaded rack of 816 kg (1,800 lb).

### Enhance Stability

A retractable, anti-tip stabilizer that can be easily extended into place is standard on all racks. It provides temporary anti-tip capability for slide-mounted products when they are in their extended position. Use the optional anti-tip ballast kit when permanent anti-tip capability is desired.

### Improve Cable Management

Agilent's 1.1 m to 2.0 m racks have an additional 100 mm of internal space that is available at the rear of the rack for installation of PDUs and as a convenient location for cables, which are routed out from the bottom of the rack. The added rear space also enhances air flow.

### Rack Dimensions

Prod. No.		Height	Width	Depth	EIA Units
<b>E3660B</b>	Exterior	1,120 mm (44.1 in)	600 mm (23.6 in)	905 mm (35.6 in)	21
	Interior*	933.45 mm (36.8 in)	450.8 mm (17.8 in)	851 mm (33.5 in)	
<b>E7590A</b>	Exterior	1,320 mm (51.9 in)	600 mm (23.6 in)	905 mm (35.6 in)	25
	Interior*	1,111.25 mm (43.8 in)	450.8 mm (17.8 in)	851 mm (33.5 in)	
<b>E3661B</b>	Exterior	1,620 mm (63.8 in)	600 mm (23.6 in)	905 mm (35.6 in)	32
	Interior*	1,422.5 mm (56.0 in)	450.8 mm (17.8 in)	851 mm (33.5 in)	
<b>E3662B</b>	Exterior	2,020 mm (79.5 in)	600 mm (23.6 in)	905 mm (35.6 in)	41
	Interior*	1,822.5 mm (71.8 in)	450.8 mm (17.8 in)	851 mm (33.5 in)	

Front to rear column hole spacing: 610 mm (24 in)  
 \*Interior = EIA units = Rackmountable space.

### Bare Rack for Multi-Bay Solutions—1.6 m and 2.0 m

A multi-bay solution is included in our product line allowing users to order bare racks without the standard side panels and rear door. This product offering allows our customers the flexibility to mix and match our rack products and eliminate extra parts, saving money, resources, and integration time.

### Rack Cabinet

#### Product Numbers for Racks Without Factory-Installed PDUs

Prod. No.	Description	Size	Color	EIA Units
<b>E3660B</b>	Rack Cabinet	1.1 m	Quartz Gray	21
<b>E3661B</b>	Rack Cabinet	1.6 m	Quartz Gray	32
<b>E3661B-AXH</b>	Bare Rack	1.6 m	Quartz Gray	32
<b>E3662B</b>	Rack Cabinet	2.0 m	Quartz Gray	41
<b>E3662B-AXH</b>	Bare Rack	2.0 m	Quartz Gray	41
<b>E5920BC</b>	Rack Cabinet	0.720 m	Quartz Gray	12
<b>E7590A</b>	Rack Cabinet	1.3 m	Quartz Gray	25

#### E3660B

<b>A</b>	1,120 mm (44.1 in)
<b>B</b>	933.45 mm (36.75 in)
<b>C</b>	120.81 mm (4.76 in)

#### E7590A

<b>A</b>	1,320 mm (51.9 in)
<b>B</b>	1,111.25 mm (43.75 in)
<b>C</b>	120.81 mm (4.76 in)

#### E3661B

<b>A</b>	1,620 mm (63.8 in)
<b>B</b>	1,422.4 mm (56.0 in)
<b>C</b>	131.83 mm (5.19 in)

#### E3662B

<b>A</b>	2,020 mm (79.5 in)
<b>B</b>	1,822.45 mm (71.75 in)
<b>C</b>	131.83 mm (5.19 in)

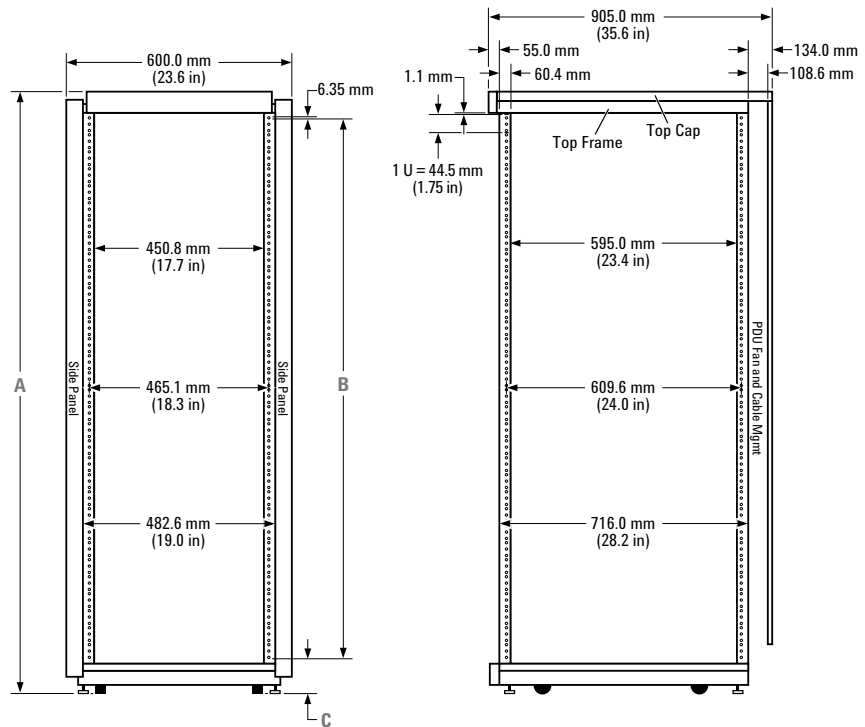

Front rack view

Side rack view

### Product Numbers for Racks with Factory-Installed PDUs

Prod. No.	Description	Size	Color	PDU
<b>E3660B-AW3</b>	Rack Cabinet	1.1 m	Quartz Gray	100/120 V (N. America)
<b>E3660B-AW5</b>	Rack Cabinet	1.1 m	Quartz Gray	200/240 V (Int'l.)
<b>E3661B-AW3</b>	Rack Cabinet	1.6 m	Quartz Gray	100/120 V (N. America)
<b>E3661B-AW5</b>	Rack Cabinet	1.6 m	Quartz Gray	200/240 V (Int'l.)
<b>E3662B-AW3</b>	Rack Cabinet	2.0 m	Quartz Gray	100/120 V (N. America)
<b>E3662B-AW5</b>	Rack Cabinet	2.0 m	Quartz Gray	200/240 V (Int'l.)
<b>E7590A-AW3</b>	Rack Cabinet	1.3 m	Quartz Gray	100/120 V (N. America)
<b>E7590A-AW5</b>	Rack Cabinet	1.3 m	Quartz Gray	200/240 V (Int'l.)

### Rack Specifications

#### Weight

Rack	Weight
<b>E3660B</b>	81 kg (179 lb) empty
<b>E7590A</b>	89 kg (196 lb) empty
<b>E3661B</b>	100 kg (221 lb) empty
<b>E3662B</b>	116 kg (255 lb) empty

**Casters Rating** 318 kg (700 lb) each, 816 kg (1,800 lb) total  
 Casters have a point contact, convex cross section

**Lift Hook Rating** 227 kg (500 lb) each  
 Total system and cabinet weight is a maximum 816 kg (1,800 lbs), static. Lift cabinet using all four (4) hooks.

#### Material

Frame/columns: 13 Ga. cold rolled steel  
 Side Panels: 18 Ga. cold rolled steel

#### Ventilation

Vented top cap  
 100 mm additional internal rear space to enhance air flow

### Ordering Information

Agilent racks can be ordered at: [www.agilent.com](http://www.agilent.com)  
 A complete catalog of Agilent racks and accessories is located at: [enclosures.agilent.com](http://enclosures.agilent.com)

### Power Distribution Units (PDUs)

The power distribution unit is a convenient way to supply power to everything mounted in the rack. The PDU is mounted vertically behind the rear column and does not reduce vertical mounting space in the rack.

A lighted master power switch is supplied with the PDU. The switch provides rapid system shutdown in case of emergency or turns off power conveniently. The switch controls a relay in 1 or 2 PDUs and uses low voltage signal lines for safety and to minimize electrical noise.

- Circuit breakers are provided on both hot (live) and neutral lines.
- All PDUs are single phase.
- A maximum of two PDUs can be installed in a rack.
- The top receptacle of all PDUs is configured as IEC-320 and is intended for the extractor fan. It can be used for other purposes if no fan is installed.
- Different power cords and sizes are offered. Select the one that is appropriate for your location and rack solution.

### PDU Order Options

PDUs can be ordered on a rack (factory installed) or as an accessory (customer installed).

To order a PDU as an accessory (installation required at the customer site):

1. Identify the size of the rack.
2. Determine the voltage required.
3. Using the Product Numbers tables below, identify the appropriate PDU.

#### PDU Product Numbers

##### PDUs for 1.1 m and 1.3 m Racks

Prod. No.	Voltage	Region
E4451A	100–120V	North America
E4452A	200–240V	North America
E4453A	200–240V	International

##### PDUs for 1.1 m and 1.3 m Racks

Prod. No.	Voltage	Region
E4455A	100–120V	North America
E4456B	200–240V	North America
E4457B	200–240V	International

4. A PDU installation kit is necessary to install the first PDU in a rack. Once a rack has a PDU installed, there is no further need for an installation kit.

For racks with factory-installed PDUs, there is no need to order separate PDUs. Information about racks with factory-installed PDUs is located in the chart on page 547.

### PDU Installation Kit

A PDU Installation Kit is required to install a PDU into a rack.

This kit includes a replacement forehead bezel containing a cutout for the lighted master power switch.

PDU	Required Parts
1st	PDU Installation Kit—Qty: 1 of E7685A.
2nd	None—the second PDU can be installed with the existing PDU installation kit (E7685A).

### Monitor Rackmount Kit

**Product Number:** J1519AC

- Quartz gray.
- The monitor rackmount kit can accommodate 14–19 inch monitors. The kit consists of a shelf, all required mounting hardware, and cosmetic panels around the monitor.
- EIA units required: 11 EIA U.

### Keyboard and Mouse Rackmount Kits

Select a fixed or retractable keyboard and mouse kit appropriate for your needs. Keyboard and mouse are not included.

#### Retractable Keyboard

**Product Number:** J1518AC

- Quartz gray.
- Keyboard security is available by using a front door on the rack cabinet.
- EIA units required: 2 EIA U.
- Includes all mounting hardware.

#### Fixed Keyboard

**Product Number:** E7714AC

- Quartz gray.
- Mounts on the outside of the front columns.
- EIA units required: 1 EIA U.
- All mounting hardware is included.

Note: Cannot be used with a front door.

### Rackmount Adapter Kits

Modules of less than 1 MW can be rackmounted using these kits.

- Individual 1/4 MW or 1/2 MW modules use the kits shown below directly.
- Combinations of 1/4 MW or 1/2 MW (of equal depth) are first joined side-by-side with the Lock Link Kit (5061-9694), then the rackmount adapter kit is applied.
- For combinations of instruments adding to 1 MW, use regular rackmount flange kit.

Kits include attaching screws and front-panel rackmounting screws. Hole patterns conform to EIA and IEC standards.

#### Rack Adapter Kits

Instrument Module Height	Mounts 1/4 mw Module	Mounts 1/2 mw Module (or 2 ea. 1/4 mw modules)	Mounts 3/4 mw Module (3 ea. 1/4 mw or 1/4 + 1/2 mw side by side)
		Mounts 1/4 MW	or 2 each 1/4 MW or 1/4 and 1/2 MW 5063-9241
88.1 mm (3 1/2 in)	5063-9239	5063-9240	5063-9241
132.6 mm (5 1/4 in)	—	5063-9243	—
177.0 mm (7 in)	—	5063-9245	—

### Support Shelf, Slides and Filler Panels

These shelves are available for instruments less than 1 MW. Refer to part numbers on page 550.

- Submodules of differing heights, widths, and depths (up to 20 inches deep) can be rackmounted using these support shelves. Any combination of 1/4 MW and 1/2 MW will fit side-by-side up to 1 MW.
- Shelves support up to 50 pounds.
- Special filler panels are available to close up vacant spaces either on top of a short module or side-by-side.
- The slide kit is required. It provides ready access to internal shelf areas and is required for installation of the support shelf. Slide kit includes brackets and mounting hardware.

### Drawers

Keep manuals or spare cables close to where they are needed. Two drawer sizes are available.

- Sliding rails and mounting hardware are included.
- Quartz gray.





Testmobile carts

### Testmobile Carts

Agilent Testmobile carts save you time and money by adding mobility and protection to test instruments and systems. Ergonomic cart and accessories design makes test equipment accessible to the operator, whether seated or standing at the test area.

Competitively priced Agilent testmobile carts are offered in three cart capacities to provide optimum instrument test configuration:

- Scope cart, 59 kg (130 lb)
- Instrument cart, 159 kg (350 lb)
- System cart, 227 kg (500 lb).

A variety of easy-to-mount accessories are available for customized solutions.

#### Add Mobility to Your Instruments

Testmobile carts provide convenient mobility of test equipment, PCs, or workstations to make them readily available when needed. This capability effectively extends the amount of lab bench space available. Mar-resistant, heavy-duty 5-inch hard rubber casters make moving instruments easy. All casters swivel, which lets the cart move right up to the workbench.

#### Bring the Equipment to the Test

Rather than bringing the test to the equipment, Testmobile carts bring the equipment to the test, which saves time and lets you get right to the task. Testmobile carts provide a convenient way to move everything from a small oscilloscope to a complete test system to the work to be tested.

#### Share Expensive Instruments

Testmobile carts allow several operators in a work group to cost-effectively share expensive equipment. In the case of a small test system, all instruments can be conveniently combined in one place through the sufficient space, load capacity, and rackmount capability of the Testmobile system cart.

#### Protect Your Investment

Unlike general-purpose cart design, Testmobile carts have a nylon strap and steel buckle that secure instruments to the cart, and instrument feet fit securely in slots in both upper tilt tray and lower fixed tray. Expensive instruments are prevented from sliding or tipping off the cart. Locking brakes on rear wheels provide added safety and convenience.

#### Use Instruments with Ease

The ergonomically designed tilt tray adjusts 30-plus degrees for viewing and using instruments in comfort whether seated or standing. Lifting and carrying heavy instruments is no longer necessary with the mobility provided by Agilent Testmobile carts.

#### Enhance Instrument Output

Testmobile system and instrument carts can be customized with a range of easy-to-mount accessories that enhance instrument input and output:

- Keyboard holder (35181N)
- Work surface and antistatic mat to provide a secure work area in front of the instrument (35183B or 35181K)
- Plotter/printer stand, which can be set up either 305 mm or 381 mm (12 in or 15 in) high, enables hardcopy output on the spot (35181H)
- Storage drawer (3.5 inch or 5.25 inch) for a convenient place to store probes, cables, and manuals
- Support shelf/storage drawer cover for the 1181B (35181J)
- Angle rails for supporting rack-mounted instruments
- Multiple outlet power strip with 6-foot cord
- New quartz-gray color

#### Testmobile Cart Selection Criteria

A key criterion for cart selection is instrument depth. For instruments with a depth up to 17 inches, select the 1180C Testmobile scope cart; up to 20 inches, select the 1182B Testmobile instrument cart; and instruments up to 25 inches, select the 1181B Testmobile system cart. Static drag chain supplied on the 1181B and the 1182B.

#### 1180C Testmobile Scope Cart

- Tilt tray load capacity = 29.5 kg (65 lb)
- Total load capacity = 59 kg (130 lb)
- Tilt tray = 457 mm W x 457 mm D (18 in x 18 in)

#### 1181B Testmobile System Cart

- Tilt tray load capacity = 90.7 kg (200 lb)
- Total load capacity = 226.8 kg (500 lb)
- Tilt tray = 559 mm W x 660 mm D (22 in x 26 in)
- Rackmount any 19-inch EIA instrument up to 24 inches deep beneath the tilt tray in EIA columns.
- 12 EIA units available for rack mounting.
- Includes one set of 5957-8476 angle rails to support rack-mounted instruments.

#### 1182B Testmobile Instrument Cart

- Tilt tray load capacity = 68 kg (150 lb)
- Total load capacity = 159 kg (350 lb)
- Tilt tray = 508 mm W x 610 mm D (20 in x 24 in)

### Specifications for Testmobile Carts

#### Testmobile

Product Number	1180C	1181B	1182B
Description	Scope Cart	System Cart	Instrument Cart
<b>Capabilities</b>			
Tilt tray load	29.5 kg (65 lb)	90.7 kg (200 lb)	68.0 kg (150 lb)
Total load	59.0 kg (130 lb)	226.8 kg (500 lb)	158.8 kg (350 lb)
Cart net weight	18.1 kg (40 lb)	39.0 kg (86 lb)	25.9 kg (57 lb)

#### Dimensions

Tilt tray size	457 mm x 457 mm (18 in x 18 in)	559 mm x 660 mm (22 in x 26 in)	508 mm x 610 mm (20 in x 24 in)
Height	721 mm (28.4 in)	721 mm (28.4 in)	721 mm (28.4 in)
Width	475 mm (18.7 in)	566 mm (22.3 in)	516 mm (20.3 in)
Depth	508 mm (20.0 in)	737 mm (29.0 in)	686 mm (27.0 in)
Vertical rack space*	n/a	533 mm (21.0 in–12 EIA U)	n/a

#### Cart Selection Criteria

Maximum Instrument Depth	432 mm (17.0 in)	635 mm (25.0 in)	508 mm (20.0 in)
--------------------------	------------------	------------------	------------------

\*Vertical rack space is reduced the more the tilt tray is angled.

### Parts List

#### Rack Cabinets

##### Standard Racks

E5920BC	0.720 m Rack Cabinet, Quartz Gray (12 EIA U)
E3660B	1.1 m Rack Cabinet, Quartz Gray (21 EIA U)
E7590A	1.3 m Rack Cabinet, Quartz Gray (25 EIA U)
E3661B	1.6 m Rack Cabinet, Quartz Gray (32 EIA U)
E3662B	2.0 m Rack Cabinet, Quartz Gray (41 EIA U)

##### Racks with Electrical Order Options

Electrical option includes: Factory-installed 1 PDU and 1 PDU installation kit. Add the option to the Standard Rack product number when ordering. (Electrical order options not available for E7590A.)

E3660B-AW3	100/120V PDU (North America)
E3660B-AW5	200/240V PDU (International)
E3661B-AW3	100/120V PDU (North America)
E3661B-AW5	200/240V PDU (International)
E7590A-AW3	100/120V PDU (North America)
E7590A-AW5	200/240V PDU (International)

##### Bare Racks: Racks without side panels or rear door

E3661B-AXH	1.6 m Bare Rack (32 EIA U)
E3662B-AXH	2.0 m Bare Rack (41 EIA U)

#### Rack Accessories

##### Power Distribution Units (PDUs)

###### For 1.1 m and 1.3 m Racks

E4451A	100/120V PDU (North America)
E4452A	200/240V (North America)
E4453A	200/240V (International)

###### For 1.6 m and 2.0 m Racks

E4455A	100/120V PDU (North America)
E4456B	200/240V (North America)
E4457B	200/240V (International)

##### PDU Installation Kits: Not needed for factory-installed PDUs.

E7685A	PDU brackets and forehead bezel replacement, Quartz gray
--------	--

##### Front Doors: Plexiglas is transparent and rim is quartz gray

E4460B	1.1 m Plexiglas Front Door
E4461B	1.3 m Plexiglas Front Door
E4462B	1.6 m Plexiglas Front Door
E4463B	2.0 m Plexiglas Front Door

#### Rear Doors

##### Vented Rear Doors

E4477B	1.6 m Vented Rear Door
E4479B	2.0 m Vented Rear Door

##### Solid Rear Doors

E4476B	1.6 m Solid Rear Door
E4478B	2.0 m Solid Rear Door

##### Tie Kits

E4466B	1.1 m Tie Kit
E4467B	1.3 m Tie Kit
E4468B	1.6 m Tie Kit
E7792A	2.0 m Tie Kit

##### Side Panels

E4458B	1.6 m Solid Side Panel
E7749A	2.0 m Solid Side Panel

##### Extractor Fans

E4470A	100/120V 200 cfm Fan
E4471A	200/240V 200 cfm Fan

##### Ballast

C2790AC	30 lb. Steel Ballast
---------	----------------------

#### Rackmount Kits

##### Monitor Rackmount Kit

J1519AC	Fits 14"–19" Monitors
---------	-----------------------

##### Keyboard Rackmount Kits

J1518AC	Retractable Keyboard
E7714AC	Fixed Keyboard

#### Instrument Rackmount Kits

##### Handles and Rackmount Flanges

Instrument Module Height	Front Handle Kit Part No.	Flange Kit Part No.	Flange Kit and Handles Part No.	Flange Kit for Inst. w/ previously supplied handles Part No.
88.1 mm (3 1/2 in)	5063-9226	5063-9212	5063-9219	5063-9232
88.1 mm (3 1/2 in)	—	5063-9213	5063-9220	—
132.6 mm (5 1/4 in)	5063-9227	5063-9214	5063-9221	5063-9234
177.0 mm (7 in)	—	5063-9228	5063-9215	5063-9222
5063-9235	—	—	—	—
221.5 mm (8 3/4 in)	5063-9229	5063-9216	5063-9223	5063-9236
265.9 mm (10 1/2 in)	5063-9230	5063-9217	5063-9224	5063-9237
310.4 mm (12 1/4 in)	—	5063-9218	5063-9225	—

#### Rack Adapter Kits

Instrument Module Height	Mounts 1/4 mw Module	Mounts 1/2 mw Module (or 2 ea. 1/4 mw modules)	Mounts 3/4 mw Module (3 ea. 1/4 mw or 1/4 + 1/2 mw side by side)
88.1 mm (3 1/2 in)	5063-9239	5063-9240	or 2 each 1/4 MW
132.6 mm (5 1/4 in)	—	5063-9243	or 1/4 and 1/2 MW
177.0 mm (7 in)	—	5063-9245	5063-9241

##### Support Shelves

88.1 mm (3 1/2 in)	5063-9255
132.6 mm (5 1/4 in)	5063-9256
177.0 mm (7 in)	5063-9257

##### Required Slide Rail Kit

1494-0015	Slide Rail Kit for Support Shelf
-----------	----------------------------------

##### Replacement Part for Support Shelf

1600-1424	Tie-down Clip
-----------	---------------

##### Support Shelf Filler Panels

For 88.1 mm (3 1/2 in) H support shelf partially filled with instruments, and having the following front panel space to fill	1/2 MW to fill 5002-3999
--	--------------------------

#### Rail Kits

E3663AC	System II Rail Kit
E3664AC	3rd Party Rail Kit
E3665AC	VXI Rail Kit
C2788BC	Computer Rail Kit

#### Slide Rail Kits

##### Slide Kit: Non-tilting, Standard-duty

1494-0060	Fits 345.4 D and 421.6 D
1494-0059	Fits 497.8 D and 574.0 D

##### Slide Kit: Non-tilting, Heavy-duty

1494-0058	Fits 345.4 D and 421.6 D
-----------	--------------------------

##### End Brackets

1494-0061	Standard-duty, Quantity: 4
1494-0064	Heavy-duty, Quantity: 4

#### Lock Link Kit

5061-9694	Lock Link Kit
-----------	---------------

**Small Parts, Cables & Adapters****Drawers**

35181J	89 mm (3.5 in) Drawer
35181M	133 mm (5.25 in) Drawer

**Plain Shelf**

J1520AC	Plain shelf (does not slide)
---------	------------------------------

**Work Surface**

46298S	Work Surface
--------	--------------

**Sliding Shelf**

J1526AC	Sliding Shelf
---------	---------------

**Rack Filler Panels**

E7731A	1 EIA Unit
E7732A	2 EIA Unit
E7733A	3 EIA Unit
E7734A	4 EIA Unit
E7735A	5 EIA Unit
E7736A	6 EIA Unit
E7737A	7 EIA Unit

**Feedthrough Panels**

E3668B	Feedthrough Panel w/2 cutout grooves
E3669B	BNC-BNC (f) to (f) Panel

**Mounting Hardware**

E7694A	50 Clip-on nuts; 50 10-32 screws; non-decorative
E7797A	50 Clip-on nuts; 50 10-32 screws; Quartz gray
0590-0804	1 Clip-on nut
0570-1366	1 10-32 screw

**Additional Hardware**

5062-3999	Locking Feet Kit
-----------	------------------

**Cables and Adapters****IEC-320 Cables**

8120-1575C	IEC-320 Female-Male Power Cable (30 in)
8120-1860	IEC-320 Female-Male Power Cable (60 in)

**Testmobiles and Accessories****Testmobiles**

1180C	Scope cart
1182B	Instrument cart
1181B	System cart

**Accessories**

35183B	Testmobile (1,180b) work surface
35181H	Testmobile plotter/printer stand
35181N	Testmobile keyboard shelf
35181J	89 mm (3.5 in) drawer
35181M	133 mm (5.25 in) drawer
35181K	Testmobile work surface
35181E	Testmobile antistatic mat for 35181D
35182C	Testmobile storage drawer (3.5 in), support shelf
35182D	Testmobile storage drawer (5.25 in), support shelf
92199B	Power strip (US) 5 receptacles
92199E	Power strip (IEC-320) 4 receptacles
8120-1575C	IEC-320 female-male power cable (30 in)
8120-1860	IEC-320 female-male power cable (60 in)
5181-8707	IEC-320 male power cable adapter

**Replacement Parts**

1530-2054C	Tie-down assembly strap for the 1180C
1530-2228C	Tie-down assembly strap for the 1181B and 1182B

**Key Literature**

Order the Enclosures Solutions Product Catalog, p/n 5980-0450E

A complete catalog of Agilent racks and accessories is located at <http://enclosures.agilent.com>



Typical Series 3000 workstation-style operating case



Typical System II Valise Transit (VT) Case



Tote-style transit case

## Operating Cases

Agilent Technologies operating cases protect instruments and equipment from the hazards of transportation and the rigors of the environment. They offer sturdy protection when instruments are transported and used on site. Operating cases are compression-molded from a glass-fiber reinforced composite material (FRP) that is lighter than aluminum and provides excellent strength and durability. Tests of this molded material show tensile and compressive strength exceeding 33,000 PSI and flexural strength exceeding 46,000 PSI.

Both standard and optional heavy-duty hardware afford excellent protection from damage and the elements. Conveniently placed, surface-mounted, spring-loaded handles fold flat when not in use, or they can be designed to reside in recesses. Front and back covers seal with O-ring gaskets and clamping latches.

### Interior Configuration

Operating cases come equipped with shock-mounted aluminum frames that accept any standard 19-inch rack-mounting instrument (EIA-RETMA standard). Most full-size instruments and modular combinations of instruments can be rack mounted in any one of our operating cases. The frame arrangement and the ability to remove the front and back covers allows for convenience of operation without removing the instrument.

## Transit Cases

Agilent transit cases are sturdy containers for use when instruments must be frequently transported or used away from laboratory or office conditions. Agilent cases protect your instruments from shock, vibration, moisture, impact, and contamination to provide a secure enclosure for shipping. Transit cases are a necessity whenever equipment is frequently transported from one operating location to another.

### Product Detail

Our transit cases are compression-molded from a glass-fiber-reinforced composite material (FRP) that is lighter than aluminum and provides excellent strength and durability. Tests of this molded material show tensile and compressive strength exceeding 33,000 PSI and flexural strength exceeding 46,000 PSI. All cases seal tightly with O-ring gaskets and clamping latches. They are rainproof under the standards of MIL-STD-810. Carrying handles are conveniently placed and are spring-loaded to fold flat when not in use.

Agilent cases are usually provided with foam cushions designed to cradle the instrument securely. The cushion inserts are typically molded polyurethane, or are fabricated from slabs of polyurethane or polyethylene flexible foams. Each case/cushion unit is designed as its own shock and vibration damping system, protecting against damage from handling, dropping, or crushing. All transit cases are available in tote style.

### How to Order

Standard transit and operating cases can be ordered from Agilent in the United States by calling 1-800-447-7278.

## Operating Cases Specifications

Nominal Rack Height ISO	in	Instrument Weight Maximum		Minimum		Case Height		Part Number
		kg	lbs	kg	lbs	mm	in	
3U	5.25	34	75	9.1	20	280.2	11.03	9211-1302
4U	7.00	34	75	9.1	20	348.7	13.73	9211-6472
5U	8.75	59	130	13.6	30	393.2	15.48	9211-1303
8U	14.00	59	130	13.6	30	527.8	20.78	9211-1241
9U	15.75	59	130	13.6	30	572.3	22.53	9211-1242
10U	17.50	59	130	13.6	30	616.7	24.28	9211-1243
12U	21.00	114	250	22.7	50	718.3	28.28	9211-1245
13U	22.75	114	250	22.7	50	762.8	30.03	9211-2636
14U	24.50	114	250	22.7	50	807.2	31.78	9211-1911
16U	28.00	114	250	22.7	50	896.1	35.28	9211-2638
17U	29.75	114	250	22.7	50	940.6	37.03	9211-2639
19U	33.25	114	250	22.7	50	1029.5	40.53	9211-1713
20U	35.00	145	320	31.8	70	1073.9	42.28	9211-6473
27U	47.25	145	320	31.8	70	1371.6	54.00	9211-2641



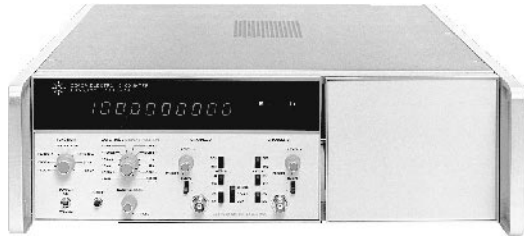

Typical System I full-module instrument



Typical System II full-module instrument

### System I Cabinet Style Transit Cases Specifications

#### Full-Module Width Instruments

Instrument Width — 425.5 mm 16.75 in

Instrument Depth — 285.8 mm 11.25 in

Inst. Height mm	in	Standard p/n	Tote-Style p/n
88.9	3.50	9211-1288	
133.4	5.25		9211-7527
177.8	7.00	9211-1290	9211-7528
222.3	8.75	9211-1291	9211-7501

Instrument Depth — 412.8 mm 16.25 in

Inst. Height mm	in	Standard p/n	Tote-Style p/n
133.4	5.25	9211-0839	9211-7502
177.8	7.00	9211-1293	9211-7503
222.3	8.75	9211-1294	9211-7504
311.2	12.25		9211-7505

Instrument Depth — 489.0 mm 19.25 in

Inst. Height mm	in	Standard p/n	Tote-Style p/n
133.4	5.25	9211-1296	9211-7507
177.8	7.00	9211-1735	9211-7508

Instrument Depth — 565.2 mm 22.25 in

Inst. Height mm	in	Standard p/n	Tote-Style p/n
311.2	12.25	9211-1297	9211-7509

#### Three-Quarters Module Width Instruments

Instrument Width — 342.9 mm 13.5 in

Instrument Depth — 500.0 mm 19.7 in

Inst. Height mm	in	Standard p/n	Tote-Style p/n
88.9	3.5	83236-60001	9211-7529
190.5	7.5	08920-90141	9211-7530

#### Half-Module Width Instruments

Instrument Width — 300.4 mm 19.7 in

Instrument Depth — 279.4 mm 11.00 in

Inst. Height mm	in	Standard p/n	Tote-Style p/n
165.1	6.5	9211-1315	9211-7511

Instrument Depth — 406.4 mm 16.00 in

Inst. Height mm	in	Standard p/n	Tote-Style p/n
165.1	6.5	9211-1734	9211-7512

#### One-Third Module Width Instruments

Instrument Width — 130.2 mm 5.125 in

Instrument Depth — 279.4 mm 11.00 in

Inst. Height mm	in	Standard p/n	Tote-Style p/n
165.1	6.5	9211-1318	9211-7506

### System II Cabinet Style Transit Cases Specifications

#### Full-Module Width Instruments

Instrument Width - 425.5 mm 16.75 in

Instrument Depth - 387.4 mm 15.25 in

Inst. Height mm	in	Standard p/n	Tote-Style p/n
88.9	3.50	9211-2642	9211-7514
133.4	5.25	9211-2643	9211-7515
177.8	7.00	9211-2644	9211-7516
222.3	8.75	9211-2645	9211-7517
311.2	12.25		9211-7518

Instrument Depth — 463.6 mm 18.25 in

Inst. Height mm	in	Standard p/n	Tote-Style p/n
88.9	3.50	9211-2648	9211-7519
133.4	5.25	9211-2649	9211-7520
177.8	7.00	9211-2650	9211-7521
222.3	8.75	9211-2651	9211-7522
266.7	10.50	9211-2652	9211-7523
311.2	12.25		9211-7478

Instrument Depth — 546.1 mm 21.50 in

Inst. Height mm	in	Standard p/n	Tote-Style p/n
88.9	3.50	9211-2654	9211-7479
133.4	5.25	9211-2655	9211-7480
177.8	7.00	9211-2656	9211-7481
222.3	8.75	9211-2657	9211-7482
266.7	10.50	9211-2658	9211-7483
311.2	12.25		9211-7484

Instrument Depth — 622.3 mm 24.50 in

Inst. Height mm	in	Standard p/n	Tote-Style p/n
88.9	3.50	9211-2660	9211-7485
133.4	5.25	9211-2661	9211-7486
177.8	7.00	9211-2662	9211-7487
222.3	8.75	9211-2663	9211-7488
266.7	10.50	9211-2664	9211-7489
311.2	12.25	9211-2665	9211-7490

#### Half-Module Width Instruments

Instrument Width — 215.9 mm 8.50 in

Instrument Depth — 247.7 mm 9.75 in

Inst. Height mm	in	Standard p/n	Tote-Style p/n
88.9	3.50	9211-2666	9211-7491
222.3	8.75		9211-7492

Instrument Depth — 323.9 mm 12.75 in

Inst. Height mm	in	Standard p/n	Tote-Style p/n
88.9	3.50	9211-2671	9211-7493
133.4	5.25	9211-2672	9211-7494
177.8	7.00	9211-2673	9211-7495
266.7	10.50		9211-7497

Instrument Depth — 400.1 mm 15.75 in

Inst. Height mm	in	Standard p/n	Tote-Style p/n
88.9	3.50	9211-2676	9211-7498
133.4	5.25	9211-2677	9211-7499
177.8	7.00	9211-2678	9211-7496



HP C2950A and C2951A Printer Cables



HP C2904A SCSI Terminator



ITEL 45CHVUC Converter

## IEEE 1284-Compliant Parallel Printer Cables

HP Printer Cables are IEEE-1284 compliant for the highest level of printer performance. These cables provide full access to the feature sets of today's advanced printers, allowing intelligent peripherals to "talk" and "listen" to their host, and resolving the bottlenecks that can occur when sending information from PC to printer and vice versa.

IEEE-1284 compliance is important. This industry standard defines the requirements for bi-directional parallel communication between personal computers and printers. It specifies electrical interfaces, cable construction, and interface hardware for high-performance cables, as well as three connector types: 1284-A, 1284-B, and the new 1284-C. These cables are designed for improved protection against radio frequency interference (RFI), electro-static discharge (ESD) damage, and data loss due to poor quality construction or crosstalk.

## USB Cables

USB (universal serial bus) cables ensure optimal communications between personal computers and an array of devices.

With this technology, Microsoft Windows users are able to expand their systems with a host of USB peripherals including printers, scanners, cameras, speakers, keyboards, joysticks, modems, and mice. As many as 127 devices can be connected to a single USB port.

Additionally, the USB cable's "hot plug" design allows for "plug and play" connections to other devices without having to power-down or reboot computers.

## Interface Converter for GPIB Controllers

Agilent offers an inexpensive solution for GPIB controllers: ITEL 45 CHVUC/EC converters. These converters enable users of GPIB controllers to connect to a wide array of HP parallel printers, including the HP LaserJet and DeskJet family of printers.

These converters have been tested and approved by Agilent to work with GPIB controllers without additional programming. Small and simple to install, they feature switch-selectable addresses and variable resolution to automatically adjust the size of graphics for HP printers, eliminating too-small and off-the-page printouts.

## GPIB Interconnection Cables

Cables for interconnecting GPIB devices are available in six lengths. The connector block at both ends of the cable has a plug on one side and a matching receptacle on the other so that several cables may be conveniently daisy-chained, thus simplifying system interconnection. Lock screws securely mount each connector block to a GPIB instrument or to another connector block.

10833 cables feature an improved shielding design to help reduce RFI levels in systems. This series of cables has significantly lower radiated emissions than previous GPIB cables.

## SCSI Cables for Hosts and Peripherals

SCSI cables are the critical link for transferring information from host to peripheral, between hosts, or between peripherals, and the latest generation offer impressive advancements.

The new SCSI cables feature Low Voltage Differential (LVD) operation for 80-megabytes-per-second transmission, plus VHDCI connectors to accommodate as many as four connectors on a single card. Ultra flexible jacketing allows for greater flexibility and easier routing.

## Ordering Information

### IEEE-Compliant Printer Cables

**C2950A** HP Printer Cable, IEEE 1284-compatible, A-B parallel 2 m (6.6 ft.)

**C2951A** HP Printer Cable, IEEE 1284-compatible, A-B parallel 3 m (9.9 ft.)

**C2946A** HP Printer Cable, IEEE 1284-compatible, A-C parallel 3 m (9.8 ft.)

**C2947A** HP Printer Cable, IEEE 1284-compatible, A-C parallel 10 m (32.8 ft.)

### USB Cable

**C6518A** A-B, 2.0 m (6.6 ft.)

### GPIB Cables

**10833A** GPIB Cable, 1 m (3.3 ft)

**10833B** GPIB Cable, 2 m (6.6 ft)

**10833C** GPIB Cable, 4 m (13.2 ft)

**10833D** GPIB Cable, 0.5 m (1.6 ft)

**10833F** GPIB Cable, 6 m (18.5 ft)

**10833G** GPIB Cable, 8 m (26 ft)

**10834A** Adapter

### Converters

**ITEL 45CHVUC** GPIB to Centronics Parallel Bus Converter

**ITEL 45CHVEC** GPIB to Centronic Parallel Bus

Converter (European version)

Must order power supply separately.

Ask for one of the following part numbers:

**F1011A** ABG Australasia

**F1011A** ABU United Kingdom

**F1011A** ABB European

**F1011A** ACQ South Africa

### SCSI 2 Cables

**C2908A** 50 HDTS m/m, 1.0 m, (3.28 ft)

**C2956A** 50 HDTS m/m, 1.5 m, (4.92 ft)

**C2957A** 50 HDTS m/m, 2.0 m, (6.56 ft)

**C2961A** 50 HDTS to 68 HDTS m/m, 1.0 m, (3.3 ft)

### SCSI 3 Cables

**C2981A** 68 HDTS m/m, 0.5 m, (1.64 ft)

**C2911A** 68 HDTS m/m, 0.9 m, (2.95 ft)

**C2924A** 68 HDTS m/m, 2.5 m, (8.2 ft)

**C2925A** 68 HDTS m/m, 10 m, (32.8 ft)

**C2926A** 68 HDTS m/m, 20 m, (65.6 ft)

### SCSI 3 Cables with Matched Impedance

**C2911B** 68 HDTS m/m, 0.9 m, (2.95 ft)

**C2924B** 68 HDTS m/m, 2.5 m, (8.2 ft)

### Ultra SCSI Cables

**C2361A** 68 HDTS to 68 VHDCI m/m, 1.0 m, (3.3 ft)

**C2362A** 68 VHDCI to 68 VHDCI m/m, 2.5 m, (8.2 ft)

**C2365A** 68 VHDCI to 68 VHDCI m/m, 5.0 m, (16.4 ft)

**C2963A** 68 VHDCI to 68 VHDCI m/m, 10 m, (32.8 ft)

### SCSI Terminators

**C2904A** Active 50 HDTS m

**C2905A** Differential 68 HDTS m

**C2972A** Single-ended active, 68 HDTS m

**C2964A** Multi-mode SE/LVD, 68 HDTS m

### Special In-line Terminated Cable









**C2908A** 68 HDTS m/f, 0.5 m (1.6 ft)









Indicates QuickShip availability.



### Ordering Information



















#### Cable Assemblies

- 10501A** 112 cm 50 Ω Coax with One UG-88C/U BNC (m) Connector 
- 10502A** 23 cm 50 Ω Coax with UG-88C/U BNC (m) Connector 
- 10503A** Like 10502A, but 122 cm 
- 8120-1838** 30 cm 50 Ω Coax with Two BNC (m) Connectors 
- 8120-1839** Like 8120-1838, but 61 cm 
- 8120-1840** Like 8120-1838, but 122 cm 
- 11000-60001** 112 cm 50 Ω Coax with Dual Banana Plugs 
- 11001-60001** 112 cm 50 Ω Coax, UG-88C/U BNC (m) to Dual Banana Plug 
- 11003A** Test Leads: 152 cm, Probe and Alligator Clip to Dual Banana Plug 
- 18182A** 152 cm WECO 310 to 2 Alligator Clips
- 92219Z** Centronics Cable 1 M
- 92224F** Female Gender Converter
- 92224M** Male Gender Converter













Model no.	Frequency range (GHz)	Length cm (in)	Connectors	SWR	Ins. loss (dB)	
<b>11500A</b>	dc to 12.4	183 (72)	N(m) (2)	—	—	
<b>11500B</b>	dc to 12.4	61 (24)	N(m) (2)	—	—	
<b>11501A</b>	dc to 18	183 (72)	N(m)-N(f)	—	—	
<b>11500C</b>	dc to 18	61 (24)	Precision N(m) (2)	1.4	1.5	
<b>11500D</b>	dc to 18	152 (60)	Precision N(m) (2)	1.4	3.0	
<b>11500E</b>	dc to 26.5	61 (24)	APC-3.5 (m) (2)	1.4	2.0	
<b>11500F</b>	dc to 26.5	152 (60)	APC-3.5 (m) (2)	1.4	4.0	

#### Adapters, 2.4 mm







(See page 106.3 for technical description and performance)

- 11900A** 2.4 mm (m) to 2.4 (m) 
- 11900B** 2.4 mm (f) to 2.4 (f) 
- 11900C** 2.4 mm (m) to 2.4 (f) 
- 11901A** 2.4 mm (m) to APC-3.5 (m) 
- 11901B** 2.4 mm (f) to APC-3.5 (f) 
- 11901C** 2.4 mm (m) to APC-3.5 (f) 
- 11901D** 2.4 mm (f) to APC-3.5 (m) 
- 11902A** 2.4 mm (m) to APC-7 
- 11902B** 2.4 mm (f) to APC-7 
- 11903A** 2.4 mm (m) to Type N (m) 
- 11903B** 2.4 mm (f) to Type N (f) 
- 11903C** 2.4 mm (m) to Type N (f) 
- 11903D** 2.4 mm (f) to Type N (m) 
- 11904A** 2.4 mm (m) to K (m)<sup>5</sup> 
- 11904B** 2.4 mm (f) to K (f)<sup>5</sup> 
- 11904C** 2.4 mm (m) to K (f) 
- 11904D** 2.4 mm (f) to K (m) 
- 11904S** 2.4 mm (f) to K adapter set 







#### Adapters Type N, Standard 50 Ω

- E9621A** N (f) to BNC (m) 
- E9623A** N (m) to BNC (m) 
- 1250-0176** N (m) to N (f) Right Angle (use <12 GHz) 
- 1250-0559** N tee, (m)(f)(f) 
- 1250-0777** N (f) to N (f) 
- 1250-0778** N (m) to N (m) 
- E9635A** N (m) to BNC (f) 
- 1250-0846** N tee (f)(f)(f) 
- 1250-1250** N (m) to SMA (f) 
- 1250-1404** N (f) to SMA (f) 
- 1250-1636** N (m) to SMA (m) 
- 1250-1741** SMA Right Angle, (f) (m) 









#### Adapters Type N, Precision 50 Ω<sup>1</sup>

- 1250-1472** N (f) to N (f) 
- 1250-1473** N (m) to BNC (m) 
- 1250-1474** N (f) to BNC (f) 
- 1250-1475** N (m) to N (m) 
- 1250-1476** N (m) to BNC (f) 
- 1250-1477** N (f) to BNC (m) 









#### Adapters Type N, Standard 75 Ω<sup>2</sup>

- 1250-0597** N (m) (50 Ω) to N (f)(75 Ω) 
- 1250-1528** N (m) to N (m) 
- 1250-1529** N (f) to N (f) 
- 1250-1533** N (m) to BNC (m) 
- 1250-1534** N (f) to BNC (m) 
- 1250-1535** N (m) to BNC (f) 
- 1250-1536** N (f) to BNC (f) 





#### Adapters APC-3.5

- 1250-1743** APC-3.5 (m) to N (m) 
- 1250-1744** APC-3.5 (f) to N (m) 
- 1250-1745** APC-3.5 (f) to N (f) 
- 1250-1746** APC-3.5 (m) to APC-7 
- 1250-1747** APC-3.5 (f) to APC-7 
- 1250-1748** APC-3.5 (m) to APC-3.5 (m) 
- 1250-1749** APC-3.5 (f) to APC-3.5 (f) 
- 1250-1750** APC-3.5 (m) to N (f) 















#### Adapters Subminiature, SMA

- 1250-1158** SMA (f) to SMA (f) 
- 1250-1249** SMA Right Angle (m) (f) 
- 1250-1397** SMA Right Angle (m) (m) 
- 1250-1462** SMA (m) to SMA (f) 
- 1250-1698** SMA tee (m) (f) (f) 
- E9631A** BNC (f) to SMA (m) 
- E9632A** BNC (m) to SMA (f) 
- E9633A** SMA (m) to BNC (m) 
- E9634A** SMA (f) to BNC (m) 



#### Adapters APC-7

- 11524A** APC-7 to N (f) 
- 11525A** APC-7 to N (m) 
- 11533A** APC-7 to SMA (m) 
- 11534A** APC-7 to SMA (f) 













#### Adapters BNC, Standard 50 Ω

- 1250-0069** BNC (m) to UHF (f) 
- E9620A** Right Angle BNC (UG-306/D) 
- E9622A** BNC (f) to BNC (f) (UG-914/U) 
- E9624A** BNC (m) to BNC (m) 
- 1250-0591** BNC (f) to WECO Video (m) 
- 1250-0595** BNC (f) to BNC Triaxial (m) 
- E9625A** BNC tee (m) (f) (f) 
- E9627A** BNC (m) to Single Banana Plug 
- 10110B** BNC (m) to Dual Banana Plug 
- 1250-1830** BNC (f) to BNC Triaxial (f) 
- E9637A** BNC (f) to Dual Banana Plug 
- 1250-1236** BNC (f) to SMB (f) 
- 1250-1200** BNC (f) to SMA (m) 
- 1250-1899** BNC (f) to SMA (m) 





#### Adapters BNC, Standard 75 Ω<sup>3</sup>

- 1250-1286** Right Angle BNC (m)(f) 
- E9628A** BNC (f) to BNC (f) 
- E9629A** BNC (m) to BNC (m) 

#### Adapters Subminiature, SMB, SMC<sup>4</sup>

- 1250-0670** SMC tee (m) (m) (m) 
- 1250-0671** SMB (m) to N (m) 
- 1250-0672** SMB (f) to SMB (f) 
- 1250-0675** SMC (m) to SMA (f) 
- 1250-1023** SMC (m) to N (m) 
- 1250-1236** SMB (f) to BNC (f) 
- 1250-0674** SMB (m) to SMA (f) 
- 1250-0832** SMC (f) to BNC (f) 
- 1250-1391** SMB tee (f) (m) (m) 
- 1250-1857** SMB (f) to BNC (m) 
- 1250-1152** SMC (f) to N (m) 
- E9636A** SMC (m) to BNC (f) 

#### Adapter Kits, 7-16<sup>5</sup>

- 11906A** 7-16 to 7-16 adapter kit 
- 11906B** 7-16 to Type-N 50 Ω adapter kit 
- 11906C** 7-16 to 7mm adapter kit 
- 11906D** 7-16 to 3.5mm adapter kit 

<sup>1</sup>"Precision": typically ≥36 dB return loss to 1.3 GHz

<sup>2</sup>Type N outer conductor; center pin sized for 75 Ω characteristic

<sup>3</sup>BNC outer conductor; center pin sized for 75 Ω characteristic

<sup>4</sup>SMB and SMC are used often inside Agilent instruments for intermodule RF connections. SMB is snap-on configuration; SMC is screw-on configuration.

<sup>5</sup>The K-connector is developed and manufactured by the Wiltron Co., Morgan Hill, California.

<sup>6</sup>Refer to publication number 5968-4449E for specific contents of kits.

 Indicates QuickShip availability.

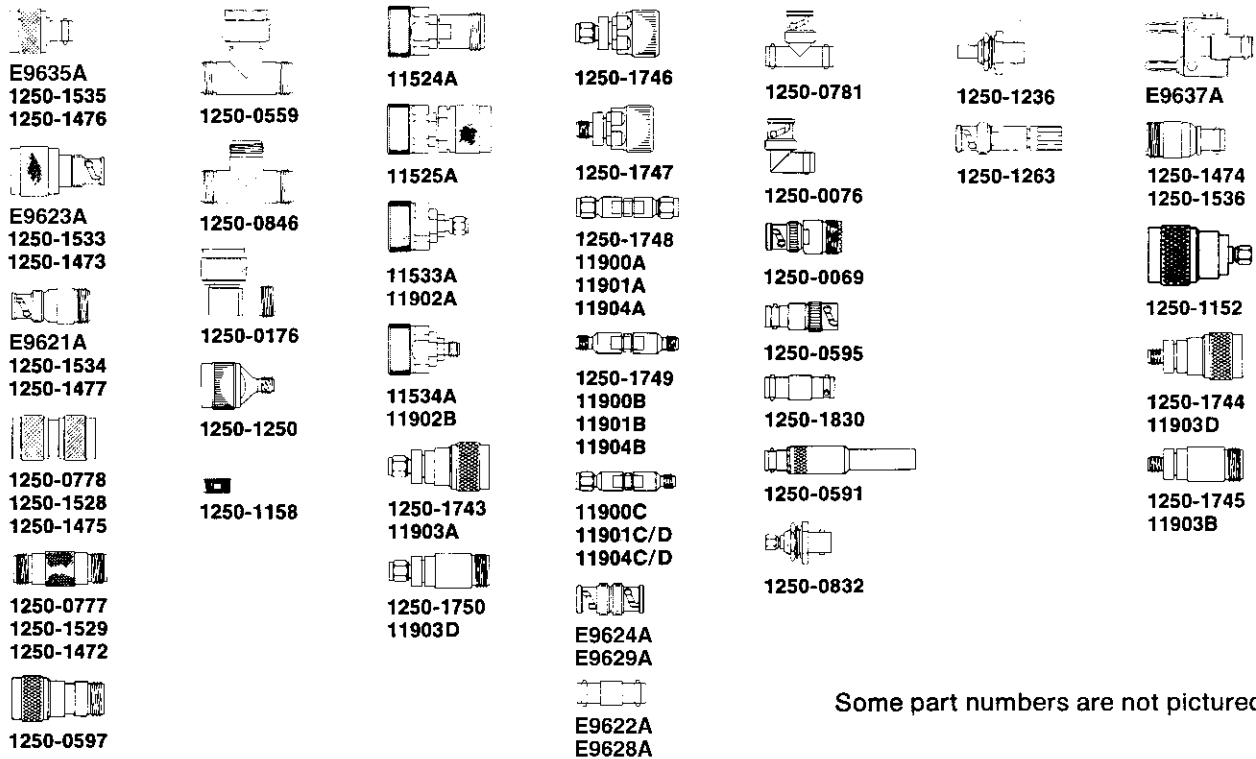
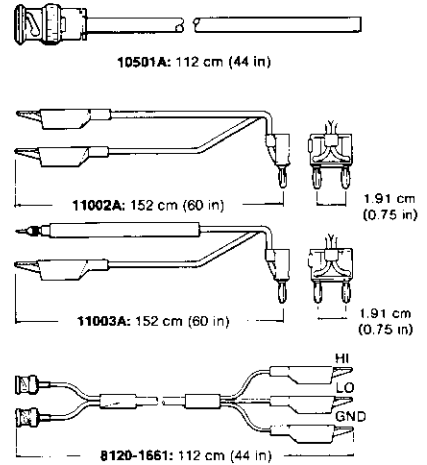
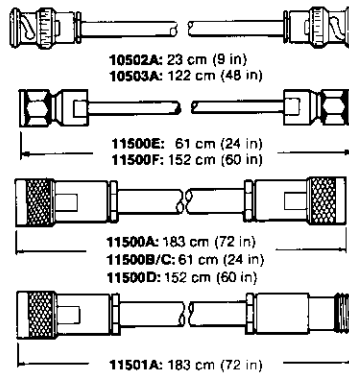
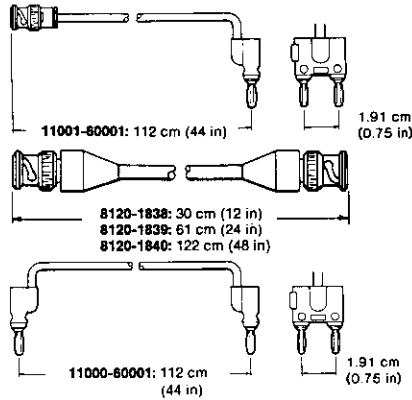

Some part numbers are not pictured.

## Coaxial Connector and Adapter Performance

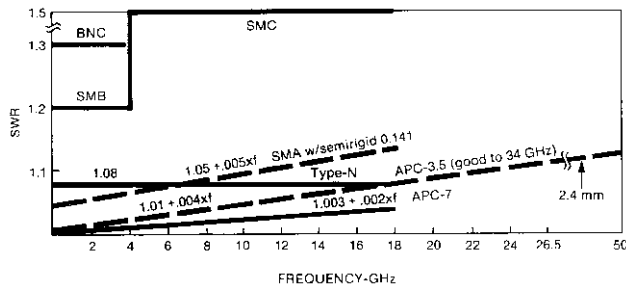

Typical SWR for connector pairs

The performance curves in the graph will help you in choosing and applying Agilent cables, connectors, and adapters. SWR curves show design specifications for mated pairs of connectors of the type indicated. You can expect typical performance in that range.

For cross-series adapters, use the curve with the highest SWR in each case. For applications of Tee-adapters such as 1250-0559, 1250-0846, and 1250-0781, be sure to consider the extra shunt capacitance of the Tee.

Of course, when Agilent mounts various connectors onto RF and microwave products, the product specification predominates and SWR is often far superior to that shown in these utility curves. For example, the "precision" type-N adapters shown on these pages are for high accuracy use dc to 1.3 GHz where SWR < 1.03.

For more information on history and performance of various coax connectors, see Agilent's *Microwave Test Accessories Catalog*, p/n 5952-2843 (D), or visit our web site:

[www.agilent.com/find/mta\\_catalog](http://www.agilent.com/find/mta_catalog)



Refurbished Equipment,  
Trade Up, Leasing & Finance 558

## Powerful alternatives to business-as-usual purchasing Available on the Internet: [www.agilent.com/find/buyalternatives](http://www.agilent.com/find/buyalternatives)

**Agilent Technologies**

Search | Site Map | Login | Contact Us

Quick Search:  GO

About Agilent || Products & Services || Industries || International || Online Stores

Home > Online Store > Refurbished Equipment

**Refurbished Equipment**

- Contact Us
- Business Center
- Trade-in/Trade-up
- Service and Support
- What's New
- Standards
- Education/Training

**Refurbished Equipment**  
An even better value the second time around

**CERTIFIED AGILENT QUALITY**

- Wide selection directly from the manufacturer
- Online, real-time search capability for the instruments you need
- Calibrated & tested to as-manufactured standards
- Full warranty & Agilent service & support
- Specials with even greater discounts
- First-come, first-served - contact us quickly when you find the right product

**Product Search** GO

Enter the model number below. Go to the [Search page](#) to search by product type.

Model Number Search:  GO

**Featured Specials**

To see the latest specials click "go". GO

When you don't want to compromise quality, warranty, or service.

Agilent's refurbished equipment provides the superior test-and-measurement capability that you've come to expect, at a price that makes the value even better. We built the instruments—we know how to make them work and look as good as new.

©2000 Agilent Technologies      Use of this site indicates you accept the Terms of Use.      Privacy Statement

Search our large, real-time inventory on line for the refurbished equipment you need at [www.agilent.com/find/buyalternatives](http://www.agilent.com/find/buyalternatives)

If business-as-usual purchasing won't work for you, we can offer a multitude of alternatives. Choose the option that best suits your needs—Refurbished Equipment, the Trade-up Program or Lease and Finance plans. To learn more about each of these alternatives, see the information below and also our web site for further details:

[www.agilent.com/find/buyalternatives](http://www.agilent.com/find/buyalternatives)

With these powerful options available to help you acquire Agilent products, you won't need to consider any other company for the best values in test-and-measurement equipment. We're the only source for the quality, service and support you expect from Agilent.

### Refurbished Equipment

Our refurbished equipment gives you the superior test-and-measurement capability that you've come to rely on, at a price that makes the value even better the second time around. Search our large, up-to-the-minute inventory of high-performance equipment on line. Also, check our Specials to see if we're

featuring an instrument in our warehouse that's on your wish list. These exceptional values are snapped up quickly, so visit daily for updates.

As the original manufacturer, we are the best source of high-quality Agilent instruments. We built it—we know how to make it work and look as good as new. Read about the standards our refurbished equipment must meet and the steps our technicians follow on line. Not only do we calibrate and test all units to original manufactured standards, but we upgrade to the latest hardware and software specifications when necessary. We also provide a full warranty and Agilent service and support for every refurbished product.

### Trade-up Program

Our trade-up program lets you capitalize on your investment in previous technology. Use the program to move up to Agilent's new solutions. You acquire the latest test-and-measurement equipment while stretching your budget and disposing of instruments you no longer need.

Simply purchase an eligible new Agilent product from our large inventory, then return a product—Agilent or not—that meets the terms of the trade-up program. You'll receive a substantial credit toward your purchase.

Visit our web site for further details on the trade-up program. Then contact us to determine your equipment's trade-up value. [www.agilent.com/find/buyalternatives](http://www.agilent.com/find/buyalternatives)

### Lease and Finance

Our lease and finance options provide you with the benefits of new technology without



For more information on Refurbished Equipment, the Trade-up Program, or Lease and Finance Plans, visit our web site at [www.agilent.com/find/buyalternatives](http://www.agilent.com/find/buyalternatives)

the risk or up-front investment. We offer three plans to fit your needs:

**EasyRent** offers the convenience and flexibility of a rental with the low payments of a lease.

**The Lease Plan** gives you all the advantages of using new technology without the risk or expense of ownership.

**The Installment Plan** provides the rewards of owning the latest technology without the up-front investment.

See our web site for more information on each plan. Then contact us to determine which option best fits your needs. [www.agilent.com/find/buyalternatives](http://www.agilent.com/find/buyalternatives)

Option	Key Advantage	Length (months)	Ownership	End of Term
<b>EasyRent</b>	Low cost Convenience and flexibility Off-balance-sheet financing	12, 18, 24	Agilent	Purchase with credits of 70% of each payment made; renew month-to-month at current rate or for a longer term at a reduced rate; return with no obligation
<b>Lease Plan</b>	Pay only for the term you need Shift obsolescence risk to Agilent Option to purchase Off-balance-sheet financing	12–60	Agilent	Purchase at fixed price or fair market value; renew month-to-month at current rate; return with no obligation
<b>Installment Plan</b>	No large up-front cash outlay No down payment Tax benefits of depreciation	12–60	You	Title passes at delivery

## Agilent's web site: Get news, updated product and support information, and more, 24 hours a day.

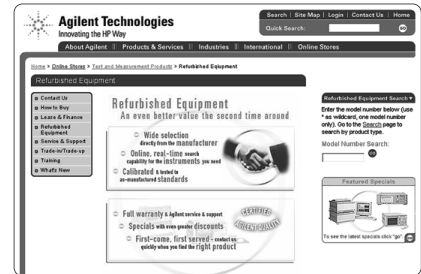
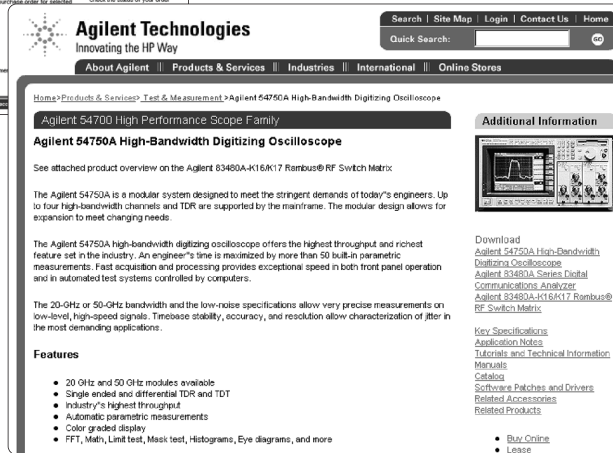

### Resources Available Online

- Product and support information more easily with helpful navigation aids and improved web pages that make it easier to access application notes, product overviews, technical details, frequently asked questions, manuals, software, news releases, education course descriptions and schedules, and much more.

- Updated comparison data and evaluation guides/tools that facilitate product selections
- Helpful application notes, downloadable interactive application notes, tutorials, online models, and other learning and problem-solving material
- Quick access to customer support services
- Information on recommended replacements for discontinued products
- Information in your local language\*
- The latest information on the status of your Agilent test and measurement order

### Take Action

- Selected Agilent products—including scopes, logic analyzers, EDA software, multimeters, data acquisition products, signal sources, counters, power supplies, and more\*
- Refurbished instruments\*
- Accessories\*
- Replacement parts\*

For more information on the test and measurement features, resources, and services available on Agilent's web site, see page 3.

Use our online test and measurement resources and services often!  
[www.agilent.com/find/tmc](http://www.agilent.com/find/tmc)

\*Availability of this feature may be limited; an expansion program is ongoing. Online purchases require a credit card.

For best results, view the Agilent web site with Microsoft's Internet Explorer browser.



# Quotations, Warranties & Local Assistance 20

Pricing, Terms, and Sales Offices 561

Quotations, Warranties & Terms of Sale	562
Local Assistance & Sales Offices	563



### Communicating with Agilent

#### Product information

Your entry point to Agilent's resources is through our Call Center at 1-800-452-4844 (for Call Center numbers outside the U.S., see pages 604–605). Our sales representatives and order support specialists are well-equipped to provide you with pre-sale assistance in product selection, as well as related business information such as current product availability and price delivered to your location.

Most Agilent Call Centers are tied into a sophisticated intra-company communications system. This allows prompt transmission of orders to any product-responsible division, and faster communication between Agilent sales offices and manufacturing facilities.

#### Electronic Data Interchange

Agilent has established Electronic Data Interchange (EDI) links with many customers to allow more timely information regarding products and orders as well as a more efficient flow of purchase orders and invoices.

#### Agilent Web Site

Be sure to visit the T & M Area of the Web site for comprehensive technical, application, support, training, and sales contact information:

[www.agilent.com/find/tmc](http://www.agilent.com/find/tmc)

### Pricing and Quotations

Prices in this catalog are U.S. list prices at the time of approval for printing. Agilent reserves the right to change prices. The price for an order is determined by the price prevailing at the time the order is received. Therefore, any prices in this catalog are intended only as budgetary information. To obtain destination prices, formal quotations, pro forma invoices, or other information before ordering, contact the Agilent Call Center in your region.

#### Inside the USA:

Call the Test & Measurement Customer Business Center, 1-800-829-4444, or write, P.O. Box 4026, Greenwood, CO 80155-4026.

#### Outside the USA:

Requests for quotations outside the USA should be placed with an Agilent Call Center or distributorship in the country of end use (see pages 604–605).

### Placing Your Order

Because many products or configurations are changed or improved during the year, we suggest that you always contact your nearby Agilent sales office for current product and pricing information prior to placing your order.

Agilent wants to be sure the product delivered to you is exactly the one you want. Therefore, when placing your order, please specify the product model, accessory, or part number, as well as the product name. Be as complete as possible in specifying exactly what you want, including standard options.

If you want special features or capabilities, such as different color or a non-standard voltage, first ask your local Agilent Call Center representative about availability and cost. Be sure to include any special instructions and specification details with your order.

### Terms of Sale

#### Inside the USA:

Agilent's standard terms for established customers in the USA are net 30 days from invoice date. Other terms are contained in the customer's purchase agreement.

Leasing, rental, and extended financing are available. However, the financing costs are not included in any product prices in this catalog. Contact your local Call Center to find out which finance options are available in your area.

#### Outside the USA:

Please contact your nearest Agilent Call Center or an authorized Agilent subsidiary or distributor regarding terms for orders placed with them.

### U.S. Government Sales

For U.S. government sales, contact the Agilent U.S. Government Business Center at 1-800-468-8347. Many products in this catalog are covered on General Services Administration (GSA) federal supply schedule multi-award contracts. Agilent's Government Business Center can supply GSA contract numbers for government purchasing officers.

### Shipping

#### Inside the USA:

All prices include Agilent standard transportation and routing to any U.S. destination. If a different shipping method is needed, we will gladly ship to satisfy your requirements. Custom shipments are typically sent freight collect.

#### Outside the USA:

Shipments to destinations outside the USA are made by either surface or air, as requested. Contact your Agilent sales office for details.

### Product Changes

Although product information and illustrations in this catalog were current at the time it was approved for printing, Agilent, in a continuing effort to offer excellent products at a fair value, reserves the right to change specifications, designs, and models without notice. To find information on recommended replacements for discontinued products, contact your local Agilent Call Center or go online at [www.agilent.com/find/migrated](http://www.agilent.com/find/migrated)

### Operating Environments

Agilent provides solutions to customer needs through products that must operate in numerous environments. To address these needs, all new hardware designs are tested and evaluated according to internal Agilent standards on operating environments before manufacturing release. These internal standards are derived from Agilent's experience with existing environments at customer installations and from other well-known standards, such as IEC, ISO, ANSI, and MILITARY. These codes are not used for evaluating production units. The following classification codes are used to identify expected environments where Agilent products or systems may be used:

- A1— Rugged Environment
- A2— Outdoor Environment (Portable)
- B1— General-Purpose Environment (Portable)
- B2— General-Purpose Environment
- C1— Controlled Office Environment
- C2— Controlled Computer Room Environment

The classifications range from severe environments found in heavy industrial areas unsuitable for operating personnel (Class A1) to the controlled environments found in dedicated computer rooms (Class C2). Most Agilent hardware products are designed to meet Class B2, applying parameters commonly found in general-purpose applications of light industrial and commercial facilities.

If you are considering a specific product, ask your Agilent sales representative which code is applicable (A1, A2, B1, B2, C1, C2) and the limits it met for your environmental parameters.

### Warranty

As an expression of confidence that our products will continue to meet the high standards of reliability and performance that our customers expect, Agilent products carry the following limited warranty:

Agilent Technologies products are warranted against defects in materials and workmanship. If Agilent Technologies receives notice of such defects during the warranty period, Agilent Technologies shall, at its option, either repair or replace hardware products that prove to be defective.

*For more information on Agilent Technologies Test & Measurement products, applications or services, please call your local Agilent sales offices listed below. A current listing is also available:*  
<http://www.agilent.com/find/assist>

**Area Sales Offices arranged alphabetically by region.**

## Americas

### United States

Product Selection & Support  
Tel: 800 452 4844

Product Purchase  
Tel: 800 829-4444  
Fax: 800 829-4433

Technical & Consulting Service  
Tel: 800 452-4844

Instrument Repair & Calibration  
Tel: (800) 403 0801

Contract Options  
Tel: (800) 861-4367

Upgrades & Retrofits (identify and select)  
Tel: (800) 452-4844

Upgrades & Retrofits (order)  
Tel: (800) 829-4444  
Fax: (800) 829-4433

Upgrades & Retrofits (schedule installation)  
Tel: (800) 403-0801

Order Instrument Parts & Manuals  
Tel: 877 447-7278

Find Parts, Manual Numbers  
Tel: 916 783-0804  
Fax: 800 333-1917

Training, Class Schedule & Registration  
Tel: 800 593 6632

### For Federal Government Orders:

Agilent Technologies  
P.O. Box 1487  
Rockville, MD 20849-1487  
Tel: (800) 468-8347  
Fax: (800) 437-1085

### For Information About US Local Sales Offices:

Tel: 1877-4AGILENT

## Canada

Product Selection & Support  
Tel: 877 894-4414

Product Purchase  
Tel: 800 276-8661  
Fax: 800 746-4866

Instrument Repair & Calibration  
Tel: 888 447-7378  
Contract Options  
Tel: 800 276-8661

Training  
Tel: 800 561-3276  
Fax: 800 746-4866  
E-mail: [tmoeduc@agilent.com](mailto:tmoeduc@agilent.com)

## Local Offices

### Alberta

Agilent Technologies Canada Inc.  
#20, 2150-29th Street NE  
Calgary, Alberta  
T1Y 7G4  
Tel: 1-877-429-9969

### British Columbia

Agilent Technologies Canada Inc.  
Crestwood Corporate Centre,  
Suite 160  
13551 Commerce Parkway  
Richmond, British Columbia  
Tel: 1-877-429-9969

### Ontario

Agilent Technologies Canada Inc.  
2660 Matheson Blvd. East  
Mississauga, Ontario  
L4W 5G1  
Tel: (905) 282-0511  
Toll-free: 1-877-429-9969  
Fax: (905) 206-4739

Agilent Technologies Canada Inc.  
2670 Queensview Drive  
Ottawa (BOLD), Ontario  
K2B 8K1  
Tel: 1-877-429-9969  
Fax: (613) 820-0377

### Quebec

Agilent Technologies Canada Inc.  
17500 Trans Canada Highway  
South Service Road  
Kirkland, Quebec  
H9J 2X8  
Tel: (514) 428-4770  
Fax: (514) 428-2188

**Latin America****Headquarters—Latin America**

Agilent Technologies  
5200 Blue Lagoon Drive, Suite  
470  
Miami, FL 33126  
Tel: (305) 269-7500  
Fax: (305) 269-7599

**Local Offices****Argentina**

Product Selection, Purchase &  
Support  
Tel: (5411) 4787-7115  
Fax: (5411) 4787-7287

Equipment Service  
Tel: (5411) 4787-7294  
Fax: (5411) 4787-7263

Training  
Tel: (5411) 4787-7115  
Fax: (5411) 4787-7287

Agilent Technologies Argentina  
S.R.L.  
Montaneses 2140/50  
1428 Buenos Aires  
Tel: (5411) 4787-7115  
Fax: (5411) 4787-7287

**Belize**

All Assistance  
Tel: (503) 264-4713  
Fax: (503) 263-3734  
Contacto: Arne Guerra  
E-mail: aguerra@setisa.com.sv  
Atendido por SETISA, El  
Salvador

**Bolivia**

All Assistance  
Tel: (5982) 902-0314  
Fax: (5982) 900-8176  
Contacto: Pablo Braga  
E-mail: pbraga@conatel.com.uy  
Atendido por Conatel S.A.,  
Uruguay

**Brazil**

Product Selection, Purchase &  
Support  
Tel: (11) 7297-3600  
Fax: (11) 7297-3933  
E-mail: tmobrasil@agilent.com

Equipment Service  
Tel: (11) 7297-3700  
Fax: (11) 7297-3773  
E-mail: tmobrasil@agilent.com

Training  
Tel: (11) 7297-3600  
Fax: (11) 7297-3937  
E-mail: tmobrasil@agilent.com

Agilent Technologies Brasil Ltda  
Alameda Araguaia, 1142  
06455-940-Alphaville-Barueri  
Sao Paulo - Brazil  
Tel: (55-11) 7297-3600  
Fax: (55-11) 7297-3933  
E-mail: tmobrasil@agilent.com

**Chile**

All Assistance  
Tel: (562) 343-7630  
Fax: (562) 274-4998  
E-mail: 3g@entelchile.net

3G Instrumentación Electrónica  
Ltda.  
Av. 11 de Septiembre 1945,  
Of. 802, Providencia  
Santiago, Chile  
Contacto: Hugo González, Eric  
González

**Colombia**

All Assistance  
Tel: (571) 612-1313  
Fax: (571) 612-0805  
E-mail: w\_moreno  
@tec.instrum.com.co  
instrum@andinet.com

Instrumentación Ltda.  
Calle 115 No. 11A-10  
Apartado 100.803  
Santafé de Bogotá, Colombia  
Contacto: William Moreno,  
Lisandro Mendoza

**Costa Rica**

All Assistance  
Tel: (506) 573-8170  
Fax: (506) 573-8171  
E-mail: acarballo@aec.co.cr

AEC Electrónica (All products)  
600 Metros Sur  
Parque Industrial Cartago  
Cartago, Costa Rica  
Contacto: Alfredo Carballo

**Dominican Republic**

All Assistance  
Tel: (809) 563-6350  
Fax: (809) 565-0332  
E-mail: f.britto  
@esacomp.com.do

Esacomp S.A.  
Calle Seminario No. 55  
Ens. Piantini  
Santo Domingo, República  
Dominicana  
Contacto: Fabio Brito

**Ecuador**

All Assistance  
Tel: (593) 233-4257  
Fax: (593) 233-1595  
E-mail: cusbeck@ECNET.ec

Complementos Electrónicos  
S.A.  
Calama 137 y 6 de Diciembre  
Quito, Ecuador  
Contacto: Carlos Usbeck

**El Caribe**

Tel: (410) 229-1555  
Fax: (410) 229-1480  
E-mail: kabeche@tessco.com

TESSCO  
11126 McCormick Road  
Hunt Valley, MD 21031-1494  
Contacto: Elias Kabeche

**El Salvador**

All Assistance  
Tel: (503) 264-4713  
Fax: (503) 263-3734  
E-mail: aguerra@setisa.com.sv  
Contacto: Arne Guerra

Servicios Técnicos de Ingeniería  
(SETISA)  
Colonia Escalón, 79 Ave. Norte  
y 7a. Calle Poniente, Casa  
#4051  
San Salvador, El Salvador

**Guatemala**

All Assistance  
Tel: (502) 363-0423  
Fax: (502) 363-0443  
E-mail: eptel@gold.guate.net



Empresa Profesional de  
Telecomunicación (EPTEL)  
12 Avenida 17-35 Zona 10  
Guatemala, Guatemala  
Contacto: Jorge Calderón

#### Honduras

All Assistance  
Tel: (503) 264-4713  
Fax: (503) 263-3734  
Contacto: Arne Guerra  
E-mail: [aguerra@setisa.com.sv](mailto:aguerra@setisa.com.sv)

Atendido por SETISA, El  
Salvador

#### Mexico

Product Selection & Purchase  
Tel: (5) 258-5721

Financing  
Tel: (5) 258-4863

Technical Support & Training  
Tel: (5) 258-4209

Equipment Service  
Tel: (5) 258-4826  
Fax: (5) 258-4665

#### Guadalajara

Agilent Technologies México  
Parque Industrial Tecnológico  
Av. Camino al ITESO 8900  
Col. Pinar de la Calma  
45080 Tlaquepaque, Jal.  
México  
Tel: (3) 134-5820/  
(3) 134-5835  
Fax: (3) 134-5851

#### Mexico D.F.

Agilent Technologies México  
Prolongación Paseo de la  
Reforma 700  
Col. Lomas de Santa Fe  
01210 Mexico, D.F.  
Tel: (5) 258-4389/  
(5) 258-4392  
Fax: (5) 261-5714  
Agilent Directo:  
01-800-506-4800 y  
(5) 261-5721  
Dirección de Correo  
Electrónico:  
EYTDIRECTO\_MEXICO  
[@agilent.com](mailto:@agilent.com)

#### Tijuana

Agilent Technologies México  
Dr. Atl No. 1, Desp. 102  
Zona Rio  
22320 Tijuana, B.C. México  
Tel: (6) 634-3801  
Fax: (6) 634-3804

#### Juárez

Agilent Technologies México  
Río Nilo 4049-8 y 9  
Fracc. Córdoba Américas  
32310 Ciudad Juárez,  
Chihuahua, México  
Tel: (16) 49-5600  
Fax: (16) 49-5620

#### Monterrey

Agilent Technologies México  
Batallón de San Patricio 111  
Fracc. Valle Oriente  
Torre Comercial América piso 27  
66269 Garza García, N.L.  
México  
Tel: (8) 368-5197  
Fax: (8) 368-7622

#### Nicaragua

All Assistance  
Tel: (503) 264-4713  
Fax: (503) 263-3734  
Contacto: Arne Guerra  
E-mail: [aguerra@setisa.com.sv](mailto:aguerra@setisa.com.sv)  
Atendido por SETISA, El  
Salvador

#### Panama

All Assistance  
Tel: (507) 279-8484  
Fax: (507) 279-8485  
E-mail: [mnjaen@multitek.com.pa](mailto:mnjaen@multitek.com.pa)

Foto Internacional S.A.  
Centro Comercial Multimax,  
Local 15  
Ave. Ricardo J. Alfaro No.P-100  
Bethania, Apdo. 55-0333-20  
Panamá, República de Panamá  
Contacto: Magda de Jaén

#### Paraguay

All Assistance  
Tel: (5982) 902-0314  
Fax: (5982) 900-8176  
Contacto: Pablo Braga  
E-mail: [pbraga@conatel.com.uy](mailto:pbraga@conatel.com.uy)  
Atendido por Conatel, S.A.,  
Uruguay

#### Peru

All Assistance  
Tel: (511) 446-2253  
Fax: (511) 444-0305  
E-mail: [erdec@satel.com.pe](mailto:erdec@satel.com.pe)

SATEL S.A.  
Jr. Arica 795  
Miraflores, Perú  
Contacto: Eliana Rey de Castro

#### Puerto Rico

Agilent Technologies Inter-  
Americas, Inc.  
Centro Europa Building  
1492 Ponce de León Avenue,  
Suite 203  
San Juan, PR 00907  
Tel: (787) 289-8912  
Fax: (787) 289-8953

#### Uruguay

All Assistance  
Tel: (5982) 902-0314  
Fax: (5982) 900-8176  
E-mail: [pbraga@conatel.com.uy](mailto:pbraga@conatel.com.uy)

Conatel S.A.  
Ejido 1690  
Montevideo, Uruguay  
Contacto: Pablo Braga

#### Venezuela

All Assistance  
Tel: (582) 207-8357  
Fax: (582) 207-8361

Equipment Service  
Tel: (582) 207-8025  
(582) 207-8026  
Fax: (582) 207-8361

Agilent Technologies, S.R.L  
Av. Francisco de Miranda con  
2da Transversal  
De Los Palos Grandes  
Edif Torre Parque Avila, Piso 12  
Caracas–Venezuela

**Asia Pacific****Headquarters—Asia Pacific**

Agilent Technologies  
24/F, Cityplaza One  
1111 King's Road  
Taikoo Shing, Hong Kong  
Tel: (852) 3197-7777  
Fax: (852) 2506-9292

**Australia**

Product Selection, Purchase & Support  
Tel: 1 800 629 485  
Fax: 03 9210 5947  
E-mail: info\_tmo@agilent.com

Equipment Service  
Tel: 1 800 802 540  
Fax: 1 800 681 776

Training  
Tel: 03 9272 8407  
Fax: 03 9272 0748

**Melbourne**

Agilent Technologies Australia Pty. Ltd.  
347 Burwood Highway  
Forest Hill, VIC 3131  
Tel: 1 800 629 485  
Fax: (03) 9210 5947

**Perth**

Measurement Innovation (WA) Pty Ltd  
7 Watercress Gardens  
Spearwood WA 6163  
Tel: 089 434 1990  
Fax: 089 434 5803

**Sydney**

Agilent Technologies Australia Ltd.  
17-23 Talavera Road  
North Ryde, N.S.W. 2113  
Tel: 1 800 629 485  
Fax: 03 9210 5947

**Bangladesh**

All assistance  
Tel: 880-2-9130480  
Fax: 880-2-8811034  
E-mail: jiu@bangla.net

Jiu International Ltd  
60 East Tejuri Bazar (2nd Floor)  
Farmgate, Dhaka -  
1215 Bangladesh  
Tel: 880-2-913-0480  
Fax: 880-2-8811034

**Brunei Darussalem**

All Assistance  
Tel: 673-2-423-918  
Fax: 673-2-441-492  
E-mail: wismicd@brunet.bn

Komputer Wisman (Sdn) Bhd  
Ground Floor, Unit 1 Block A  
Abdul Razak Complex  
Jalan Gadong BSB  
Brunei Darussalem  
Tel: 673-2-423-918/425-603  
Fax: 673-2-441-492  
E-mail: wismicd@brunet.bn

**China**

Product Selection & Product Purchase  
Tel: 86 10 65645238  
Fax: 86 10 65668250  
E-mail: Ying\_LIU@Agilent.com

Technical Support  
Tel: 86 10 65645261  
Fax: 86 10 65668250  
E-mail: Maggie\_XY\_Liu@Agilent.com

Equipment Service  
Tel: 86 10 62613819  
Fax: 86 10 62614256  
E-mail: Zhonghua\_Hu@Agilent.com

Parts selection and purchase  
Phone: 800-810-0189  
Fax: 86-10-65668250

Training  
Tel: 86 10 65645293  
Fax: 86 10 65668249  
E-mail: Grace-Jia\_Zheng@Agilent.com

**Beijing**

Agilent Technologies Co. Ltd.  
HP Building  
No.2, Dong San Huan Nan Lu  
Chao Yang District  
Beijing 100022, PRC  
Tel: (86-10) 6564-5500,  
800-810-0189  
Fax: (86-10) 6566-8250

**Chengdu**

Agilent Technologies Co. Ltd.  
22/F Daye Road  
No. 39 Daye Road  
Chengdu 610016 PRC  
Tel: (86-28) 665-5500  
Fax: (86-28) 667-4321

**Guangzhou**

Agilent Technologies Co. Ltd.  
7/F T.P.Plaza  
9/109, Liu Hua Road  
Guangzhou 510010 PRC  
Tel: (86-20) 8668-5500  
Fax: (86-20) 8669-5074  
Telex: 44556 GPHGZ CN

**Shanghai**

Agilent Technologies Co., Ltd.  
10-12/F Novel Building  
No. 887 Huai Hai Zhong Lu  
Shanghai, 200020  
Tel: (86/21) 6474-5500  
Fax: (86/21) 6474-8523  
Telex: 086-33577 CHPSB CN

**Shenyang**

Agilent Technologies Co., Ltd.  
12/F Shenyang Sankei Torch  
Building No. 262 Shifu Road,  
Shenhe District  
Shenyang 110013 PRC  
Tel: (86/24) 22791588  
Fax: (86/24) 22791755

**Hong Kong, SAR**

Product Selection, Technical & Consulting services  
Tel: (852) 3197 7889  
Fax: (852) 2506 9256

Product Purchase  
Tel: 800-90-8481  
Fax: 800-90-8476

Equipment Service  
Tel: 800-93-3229  
Fax: 800-90-8476

Training  
Tel: (852) 3197 7889  
Fax: (852) 2506 9233

Agilent Technologies (HK) Ltd.  
24/F, Cityplaza One,  
1111 King's Road,  
Taikoo Shing,  
Hong Kong, SAR  
Tel: (852) 3197-7777  
Fax: (852) 2506-9256

**India**

Product Information  
Tel: 011-6826415 ext 6624  
Fax: 011-6826027  
E-mail: neeru\_gambhir@agilent.com

Product Purchase  
Tel: 011-6826262  
Fax: 011-6826027  
E-mail: nisha\_malhotra@agilent.com

Technical & Application Assistance  
Tel: 011-6826415 ext 6625  
Fax: 011-6826421  
E-mail: madhulika\_bawa@agilent.com

Consulting & Integration Services  
Tel: 080-2091813  
Fax: 080-2256186  
E-mail: shyla\_hanumaiah@agilent.com

Upgrades, Retrofits & Repair  
Tel: 080-3435755  
Fax: 080-3335316  
E-mail: t-k\_prabhakar@agilent.com

Contract Options  
Tel: 080-2091841  
Fax: 080-2289274  
E-mail: rajan\_sunder@agilent.com

Training  
Tel: 011-6826415 ext 6625  
Fax: 080-6826421  
E-mail: madhulika\_bawa@agilent.com

**Bangalore**

Agilent Technologies India Pvt. Ltd.  
Embassy Point  
150 Infantry Road  
Bangalore 560001  
Tel: 91-80-209-1890  
91-80-209-1808  
Fax: 91-80-228-9274  
91-80-225-6187  
Telex: 845-2773 HP IN  
For customers located in Karnataka and Kerala

**Calcutta**

Agilent Technologies India Ltd.  
708 Central Plaza  
2/6 Sarat Bose Road  
Calcutta 700020, India  
Tel: (91-33) 4747730/31  
Fax: (91-33) 4748571  
For customers in West Bengal, Bihar, Orissa and all the North Eastern states

**Hyderabad**

Agilent Technologies India Pvt. Ltd.  
5-9-13 Taramandal Complex  
9th Floor, Saifabad  
Hyderabad 500 004  
Tel: (91-40) 3232-679  
Fax: (91-40) 3231-756  
Telex: 425-2422 HPIL IN  
For customers in Andhra Pradesh and Tamil Nadu

**Mumbai**

Agilent Technologies India Ltd.  
Samrat Business Centre  
"The Metropolitan"  
2nd Floor  
Bandra-Kurla Complex,  
Bandra(E)  
Mumbai 400 051  
Tel: (91/11) 654-1120/21/22  
Fax: (91/11) 654-1124  
For customers in Maharashtra, Gujarat and Madhya Pradesh

**New Delhi**

Agilent Technologies India Ltd.  
Chandiwalla Estate  
Ma Anandmai Ashram Marg,  
Kalkaji  
New Delhi 110 019  
Tel: (91-11) 682-6415  
Fax: (91-11) 682-6421  
For customers in Delhi,  
Rajasthan,  
Jammu & Kashmir, Uttar  
Pradesh, Punjab,  
Haryana and Himachal Pradesh

**Indonesia**

All Assistance  
Tel: 62-21 3800902  
Fax: 62-21 3517423  
E-mail: tmomarketing  
@berca.co.id

**Jakarta**

PT Berca Hardayaperkasa  
J1 Abdul Muis No. 62  
Jakarta 10160 Indonesia  
Tel: (62-21) 380 0902  
Fax: (62-21) 3517423  
E-mail: tmomarketing  
@berca.co.id

**Bandung**

P.T. Berca Hardayaperkasa  
Jalan Tengku Angkasa No. 33  
Bandung 40132  
Tel: (62-22) 250-8100  
Fax: (62-22) 250-6757  
E-mail: tmomarketing  
@berca.co.id

**Japan**

Headquarters  
Agilent Technologies Japan, Ltd.  
9-1, Takakura-cho, Hachioji-shi,  
Tokyo 192-8510  
Japan  
Tel: (81-3) 426-60-3111  
Fax: (81-3) 426-60-8489

Product Selection, Purchase &  
Support  
Tel: 81-426-56-7832  
Fax: 81-426-56-7840  
E-mail: mac\_support  
@om.jpn.hp.com

Equipment Service  
(Bench Support Service Center)  
Tel: 81-426-56-7799  
Fax: 81-426-56-7805

Training  
Tel: 81-44-812-9722  
Fax: 81-44-812-5364  
E-mail: jpn\_edu@agilent.com

**Local Offices****Aichi**

Agilent Technologies Japan Ltd.  
Nagoya Kokusai Center Bldg.  
1-47-1 Nakono Nakamura-ku,  
Nagoya-shi  
Aichi 450-0001

**Akita**

Agilent Technologies Japan Ltd.  
Nihonseimei Akita Chuodori Bldg.  
4-2-7 Nakadori, Akita-shi  
Akita 010-0001

**Fukuoka**

Agilent Technologies Japan Ltd.  
Daisan Hakata-Kaisei Bldg.  
1-3-6 Hakataekiminami  
Hakataku  
Fukuoka 812-0016

**Hiroshima**

Agilent Technologies Japan Ltd.  
Nissei-Heiwakoen Bldg.  
3-25 Nakajima-cho Naka-ku,  
Hiroshima-shi  
Hiroshima 730-0811

**Hokkaido**

Agilent Technologies Japan Ltd.  
Sumitomo-seimei  
Sapporo Chuo Bldg.  
1-1-14 Minaminijo-higashi  
Chuo-ku, Sapporo-shi  
Hokkaido 060-0052

**Ibaraki**

Agilent Technologies Japan Ltd.  
Tsukuba-Mitsui Bldg.  
1-6-1 Takezono, Tsukuba-shi  
Ibaraki 305-0032

**Ishikawa**

Agilent Technologies Japan Ltd.  
Kanazawa MK Bldg.  
98-8 Sainen-machi,  
Kanazawa-shi  
Ishikawa 920-0026

**Kanagawa**

Agilent Technologies Japan Ltd.  
3-2-2 Sakado  
Takatsu-ku, Kawasaki-shi  
Kanagawa 213-0012

Agilent Technologies Japan Ltd.  
9-32 Tamuracho, Atsugi-shi  
Kanagawa 243-0016

**Kobe**

Agilent Technologies Japan, Ltd.  
1-3-2 Muroya Nishi-ku, Kobe-shi  
Hyogo 651-2241

**Miyagi**

Agilent Technologies Japan Ltd.  
Yamaguchi Bldg.  
1-1-31 Ichibancho Aoba-ku,  
Sendai-shi  
Miyagi 980-0811

**Nagano**

Agilent Technologies Japan Ltd.  
Forum Honjo Bldg.  
2-4-1 Honjo, Matsumoto-shi  
Nagano 390-0814

**Osaka**

Agilent Technologies Japan,  
Ltd.  
Chuo Bldg.  
5-4-20 Nishinakajima  
Yodogawa-ku, Osaka-shi  
Osaka 532-0011

**Saitama**

Agilent Technologies Japan Ltd.  
Mitsui-seimei Omiya  
Miyamachi Bldg. 2-96-1  
Miyamachi, Omiya-shi  
Saitama 330-0802

**Tokyo**

Agilent Technologies Japan Ltd.  
9-1 Takakura-cho, Hachioji-shi  
Tokyo 192-8510

Agilent Technologies Japan Ltd.  
NAF Bldg.  
3-8-20 Takaido-higashi,  
Suginami-ku  
Tokyo 168-0072

**Korea, Republic of**

Product Selection & Purchase  
Tel: 82/2-2004-5114  
Fax: 82/2-2004-5115

Online Technical Support  
Tel: 82/2-2004-5114  
Fax: 82/2-2004-5240  
E-mail: asia\_ots-korea  
@agilent.com

Instrument Repair & Calibration  
Tel: 82/2-2004-5800  
Fax: 82/2-2004-5809

Upgrades and retrofits  
Tel: 82/2-2004-5114  
Fax: 82/2-2004-5115

Training  
Tel: 82/2-2004-5212  
Fax: 82/2-2004-5217

**Seoul**

Agilent Technologies Korea Ltd.  
25-12 Yoido-dong  
Youngdeung po-ku  
Seoul 150-010  
Yoido P.O.BOX 633  
Tel: 800- 1588-5522  
Fax: 800-772-5522

**Taegu**

Agilent Technologies Korea Ltd.  
18/F, Yeung Nam Tower 111  
Shinchun 3-dong, Dong-ku  
Taegu, S.Korea 701-023  
Tel: (82-53) 740-4900  
Fax: (82-53) 740-4989

**Taejeon**

Agilent Technologies Korea Ltd.  
8/F Hyundai B/D,  
1298 Doosan-dong, Seo-gu  
Taejeon  
Tel: (82/42) 602-2200 ~5  
Fax: (82/42) 620-2288

**Malaysia**

Product Selection, Purchase,  
Consulting & Support  
Tel: 1-800-88-8848  
Fax: 1-800-80-1664

Equipment Service  
Tel: 1-800-88-0399  
Fax: 00-800-4747-1111

Parts selection and purchase  
Tel: 1-800-88-0686  
Fax: 1-800-80-1664

Training  
Tel: 03-7719-2161  
Fax: 03-7725-4327

**Kuala Lumpur**

Agilent Technologies Sales (M)  
Sdn Bhd  
No 201, Level 2 Uptown 2  
2, Jalan SS21/37 Damansara  
Uptown  
47400 Petaling Jaya  
Selangor  
Tel: 1-800-88-8848 Toll Free  
G/L: (603) 7727- 8808  
Fax: (60/3) 7727-1209

**Penang**

Agilent Technologies Sales  
(Malaysia) Sdn Bhd  
Bayan Lepas Free Trade Zone  
11900 Bayan Lepas  
Penang  
Tel: (60/4) 642-3502  
Fax: (60/4) 642-3511

**New Zealand**

Product Selection, Purchase,  
Support & Training  
Tel: 0800 738 378  
Fax: 04 495 8950

Equipment Service  
Tel: 0800 225 530  
Fax: 0800 225 539

Parts selection and purchase  
Fax: 04 495 8945  
E-mail: cheryl\_brown  
@agilent.com

**Auckland**

Agilent Technologies  
FAI Building  
5th Floor  
220 Queens Street  
AUCKLAND

Tel: 0800 738 378  
Fax: 64 9 300 6156

**Wellington**

Agilent Technologies New  
Zealand Ltd.  
25 – 33 Victoria Street  
P.O. Box 9348  
Wellington

Sales:  
Tel: 0800 738 378  
Fax: 04 495 8950

Support:  
Tel: 0800 225 530  
Fax: 0800 225 539

**Pakistan**

All Assistance  
Tel: 92-51-274632  
Fax: 92-51-816-190  
E-mail: mushkoib  
@isb.comp.pol.com

Islamabad  
Mushko Electronics (Pvt) Ltd.  
68-W Sama Plaza, Blue Area, G-7  
Islamabad 44000  
Pakistan  
Tel: 92-51-274632/828-459  
Fax: 9251-816190  
E-mail: mushkoib  
@isb.comp.pol.com

**Karachi**

Mushko Electronics (Pvt) Ltd.  
Oosman Chambers  
Abdullah Haroon Road  
Karachi 74400  
Tel: 9221-566 0490/566  
0771/566 0773  
Fax: 9221-566-0801  
E-mail: tmo\_khi@mushko.com

**Philippines**

Product Selection & Product  
Purchase  
Tel: (632) 543-5043  
Fax: (632) 543-5027  
Online Sales: (632) 842-6802

Technical Support & Training  
Tel: (632) 543-5043  
Fax: (632) 543-5027/(632)  
543-5029  
E-mail: charlene\_rivera  
@agilent.com

Equipment Service  
Tel: 1-800-1651-0135  
Fax: 1-800-4747-1111  
E-mail: rina\_bancoro  
@agilent.com

Agilent Technologies Philippines  
Corporation  
11th Floor Asian Star Building  
Asean Drive corner Singapura  
Lane  
Filinvest Corporate City  
Alabang, Muntinlupa City  
Philippines, 1780  
Tel: (632) 543-5043  
Fax: (632) 543-5027 or (632)  
543-5029  
Online Sales: (632) 842-6802  
E-Mail Address: kaye\_derilo  
@agilent.com

**Singapore**

Product Selection & Purchase  
Tel: 1800-3758100  
Fax: 8360252  
E-mail: TM\_Asia@agilent.com

Technical Support  
Tel: 1800-3758100  
Fax: 8360252  
E-mail: TM\_Asia@agilent.com

Equipment Service  
Tel: 275-0880  
Fax: 275-0231  
E-mail: webtrack\_issd  
@agilent.com

Parts selection and purchase  
Tel: 1800-3758100  
Fax: 2750231  
E-Mail TM\_Asia@agilent.com

Training  
Tel: 2158269  
Fax: 2754709  
E-mail: hp\_academy\_singapore  
@agilent.com

Agilent Technologies Singapore  
(Sales) Pte Ltd  
438 Alexandra Road  
Alexandra Point  
Singapore 119958  
Tel: 65 377 1688  
Asia Call Center: 1 800 375 8100  
E-mail: TM\_Asia@agilent.com

**Sri Lanka**

All Assistance  
Tel: 94-74-717 701  
Fax: 941-583901  
E-mail: dayankaru@pts.co.lk

Precision Technical Services  
(Pvt) Ltd.  
401/A, R.A. De Mel Mawatha  
Colombo 00300  
Tel: 94 74 717701  
Fax: 941-583901  
E-mail: dayankaru@pts.co.lk

**Taiwan**

Product Selection, Purchase &  
Support  
Tel: 0800-47866

Equipment Service  
Tel: 0800-47866

Parts Selection and Purchase  
Tel: 00-800-6262-6288

Training  
Tel: (886/3)495-9292

**Chungli**

Agilent Technologies Taiwan Ltd.  
No. 20 Kao-Shuang Road  
Ping-Cheng, 32404  
Taoyuan Hsieh  
Taiwan, ROC  
Tel: (886/3)492-9666  
Fax: (886/3) 492-9669

**Kaohsiung**

Agilent Technologies Taiwan Ltd.  
13th Floor, 10 Syh-Wei 4th Road  
Lin-Ya District  
Kaohsiung 802  
Taiwan, ROC  
Tel: (886/7)535-5035  
Fax: (886/7) 330-8569

**Taichung**

Agilent Technologies Taiwan Ltd.  
5th Floor, 556 Sec. 1  
Wen-Hsin Road  
Taichung 408  
Tel: (886/4) 310-1789  
Fax: (886/4) 310-6393

**Taipei**

Agilent Technologies Taiwan Ltd.  
5th Floor No. 337, Fu-Hsing  
North Road  
Taipei 105  
Tel: (886-2)8712-2899  
Fax: (886-2) 2718-9860,  
2545-6723

**Thailand**

Product Selection & Purchase  
Tel: (02) 661-3999  
Toll Free Outside Bangkok (088)  
225-802  
Fax: (02) 661-3976,  
toll free 001-800-65-6317  
E-mail: tm\_asia@agilent.com

Parts Selection & Purchase  
Tel: 02 6613999  
Fax: (02) 661-3976,  
toll free 001-800-65-6317

Technical Assistance, Consulting,  
Training and Equipment Service  
Tel: 02 661-5900 ext 5001  
Fax: (02) 661-3949  
(02) 259-3443

Agilent Technologies (Thailand)  
Ltd.  
23rd FL Vibulthani Tower II  
3199 Rama IV Road  
Klong Toey, Bangkok 10110  
Tel: (662) 661-5900  
Fax: (662) 661-3946

**Vietnam**

All Assistance  
Tel: 844-8229-808/9  
Fax: 844-8229-553  
E-mail: sysco.vn@hn.vnn.vn

System Interlace Company  
39 Mai Hac De Street  
Hai Ba Trung District  
Hanoi  
Vietnam



## Europe, Middle East & Africa

### Headquarters—Europe

Agilent Technologies  
Netherlands B.V.  
Test & Measurement  
Startbaan 16  
1187 XR Amstelveen  
The Netherlands  
Tel: +31 20 547 2000  
Fax: +31 20 547 2900

### Headquarters—East Europe, Middle East/Africa

Agilent Technologies S.A.  
International Sales Europe  
Rue de Veyrot 39  
P.O. Box 364  
1217 Meyrin 1  
Geneva, Switzerland  
Tel: (41/22) 780-6111  
Fax: (41/22) 780-6770

### Local Offices

#### Albania

All Assistance  
Tel: 355-42-23519  
Fax: 355-42-27966  
E-mail: mmylonas@g-systems.gr

Gener-Al sh.p.k  
Tirana Trade Center –  
Rr. Duresit  
Tirana

#### Algeria

All Assistance  
Tel: 213-2-606450  
Fax: 213-2-691130  
E-mail: RTI@ist.cerist.dz

Realisations Telematiques  
Internationales  
26 bis, Mohamed Hadj Ahmed  
(ex Jean Pierre Dinet)  
16035 Hydra

#### Angola

Concilium Technologies in  
South Africa  
Tel: 2711 444 8010  
Fax: 2711 444 8511  
E-mail: info@concilium.co.za

#### Armenia

Contact Agilent Technologies in  
Switzerland  
All Assistance  
Tel: +41 22 780 6136  
Fax: +41 22 780 69 22  
E-mail: marylin\_breux  
@agilent.com

#### Austria

Agilent Technologies Österreich  
GmbH  
Elektronische Messtechnik  
Lieblgasse 1  
A-1222 Vienna  
Tel: (01) 25125-7006  
Fax: (01) 25125-6558  
E-mail: messtechnik\_vertrieb  
@agilent.com

Service  
Tel: (01) 25125- 7000  
Fax: (01) 25125-6558  
E-mail: a\_messtechnik-service  
@agilent.com

#### Bahrain

All Assistance  
Tel: +973 723 050  
Fax: +973 725 070  
E-mail: psehgai@batelco.com.bh

Al Moayed Telecom  
Ground Floor,  
Al Taweela Complex  
Juffair, Manama  
Bahrain

#### Belarus

All Assistance  
Tel: 375-172-174 491/2  
Fax: 375-172-174 496  
E-mail: fan@dm-trade.com

DMT  
Oktiabrskaja str. 12a  
2200304 Minsk

#### Belgium

Product Selection & Product  
Purchase  
Tel: 32-2-404 9340  
Fax: 32-2-404 9395  
E-mail: customercare\_benelux  
@agilent.com

Equipment Service  
Tel: 32-2-404 9303  
Fax: 32-2-404 9391  
E-mail: customercare\_benelux  
@agilent.com

Training  
Tel: 31-20-654-5563  
Fax: 31-20-654-5558  
E-mail: customercare\_benelux  
@agilent.com

Agilent Technologies Belgium  
S.A./N.V.  
Test & Measurement  
Boulevard de la Woluwe 100  
B 1200 Brussels  
Tel: 32-2-404 9340  
Fax: 32-2-404 9395  
E-mail: customercare\_benelux  
@agilent.com

#### Benin

Handled by CIS Ivory Coast

#### Bosnia-Herzegovina

All Assistance  
Tel: 386-611 895 271  
Fax: 386-611 895 203  
E-mail: vito.podlogar@hermes-  
plus.si

Hermes Plus  
Slandrova 2  
1231 Ljubljana Crnuce

#### Botswana

Concilium Technologies in  
South Africa  
Tel: 2711 444 8010  
Fax: 2711 444 8511  
E-mail: info@concilium.co.za

#### Bulgaria

Test Solutions EOOD  
Agilent Distributor  
3/A "Sofiyski geroy" Str.  
Sofia 1612  
Tel: 359 2 95 33 548/  
359 2 95 33 558  
Fax: 359 2 95 31 947  
E-mail: venelina\_iordanova  
@mtel.net

#### Burkina Faso

Computer Information Systems,  
Lebanon  
Tel: +961 4 405 413  
Fax: +961 4 525 181  
E-mail: michel\_nassif  
@cis.com.lb

#### Burundi

Handled by CIS Ivory Coast

#### Cameroon

CIS Cameroon  
Residence "La Rose"  
P.O.Box 12914  
Bonanjo, Douala  
Tel: +237 425148  
Fax: +237 425 544

#### Central African Republic

Contact Agilent Technologies  
in Switzerland  
All Assistance  
Tel: +41 22 780 6136  
Fax: +41 22 780 69 22  
E-mail: marylin\_breux  
@agilent.com

#### Chad

Contact Agilent Technologies  
in Switzerland  
All Assistance  
Tel: +41 22 780 6136  
Fax: +41 22 780 69 22  
E-mail: marylin\_breux  
@agilent.com

#### Congo

CIS Congo  
Villa Adjacente au Score  
P.O.Box 1140  
Pointe Noire  
Tel: +242 947291  
Fax: +242 947292

#### Croatia

All Assistance  
Tel: 38-512-331061  
Fax: 38-512-331930  
E-mail: eugen.zeneral@hermes-  
plus.hr

Hermes Plus  
Osekovska 18  
41000 Zagreb

#### Cyprus

All Assistance  
Tel: 30-175 64045  
Fax: 30-175 64020  
E-mail: mmylonas@g-  
systems.gr

G-Systems  
76, Ymittou Street  
11634 Athens

#### Czech Republic

All Assistance  
Tel: +420 2 333 21 707  
Fax: +420 2 333 20 672  
E-mail: haasz@htest.cz

H TEST a.s.  
Na baste sv. Jiri 11  
16000 Praha 6  
Czech Republic

#### Denmark

All Assistance  
Tel: 70 13 73 13  
Fax: 45-82-06-30

Agilent Technologies Danmark  
Test- og Måleudstyr  
Kongevejen 25  
3460 Birkerød

**Djibouti**

Contact Agilent Technologies  
in Switzerland  
All Assistance  
Tel: +41 22 780 6136  
Fax: +41 22 780 69 22  
E-mail: marylin\_breux  
@agilent.com

**Egypt**

All Assistance  
Tel: 202 3015 280/  
202 302 6930  
Fax: 202-3440 201  
E-mail: boktor@orascom.com  
Telex: 92768 orscm un

Orascom  
160, 26th July Street  
P.O. Box 1191  
Aguza—Cairo

**Equatorial Guinea**

Contact Agilent Technologies  
in Switzerland  
All Assistance  
Tel: +41 22 780 6136  
Fax: +41 22 780 69 22  
E-mail: marylin\_breux  
@agilent.com

**Eritrea**

Contact Agilent Technologies  
in Switzerland  
All Assistance  
Tel: +41 22 780 6136  
Fax: +41 22 780 69 22  
E-mail: marylin\_breux  
@agilent.com

**Ethiopia**

ACP SERIC  
Bole Road  
P.O.Box 2764  
Addis Abeba  
Tel: +251 1 513976  
Fax: +251 1 511298

**Finland**

All Assistance  
Tel: 358-10-855 2100  
Fax: 358-10-855 2923  
E-Mail Address: tm\_finland  
@agilent.com

Equipment Service  
Tel: 358-10-855 2360

Agilent Technologies Finland Oy  
Street Address:  
Piispankalliontie 17  
02200 ESPOO  
Finland  
P.O.Box Address:  
PL 8  
02201 ESPOO  
Finland

**France**

Product Selection, Purchase &  
Support  
Tel: 01.69.29.41.14  
Fax: 01.69.82.65.35

Equipment Service  
Tel: 01.69.82.66.66  
Fax: 01.69.82.66.26

Training  
Tel: 01.49.93.22.72  
Fax: 01.49.93.22.83

Agilent Technologies France  
Test et Mesure  
Z.A. de Courtaboeuf  
1 Avenue du Canada  
91947 Les Ulis  
Tel: 01 69 29 41 14  
Fax: 01 69 29 65 09

**Gabon**

CIS Gabon  
Face Base Navale  
Port Gentil  
Tel: +241-759693  
Fax: +241-561233

**Gambia**

Contact Agilent Technologies  
in Switzerland  
All Assistance  
Tel: +41 22 780 6136  
Fax: +41 22 780 69 22  
E-mail: marylin\_breux  
@agilent.com

**Georgie**

Contact Agilent Technologies  
in Switzerland  
All Assistance  
Tel: +41 22 780 6136  
Fax: +41 22 780 69 22  
E-mail: marylin\_breux  
@agilent.com

**Germany**

All Assistance  
Tel: (01805) 24-6330  
(DM 0.24/Min.)  
Fax: (01805) 24-6331  
(DM 0.24/Min.)  
E-mail: messtechnik\_vertrieb  
@agilent.com

Training  
Tel: (07031) 464-8970  
Fax: (07031) 464-8814  
E-mail: consulting\_DACH  
@agilent.com

Service  
Tel: (01805) 24-6337  
(DM 0.24/Min.)  
Fax: (01805) 24-6338  
(DM 0.24/Min.)  
E-mail: d\_messtechnik-service  
@agilent.com

**Bad Homburg**

Agilent Technologies  
Deutschland GmbH  
Elektronische Messtechnik  
Hewlett-Packard-Straße 1  
D-61352 Bad Homburg

**Berlin**

Agilent Technologies  
Deutschland GmbH  
Elektronische Messtechnik  
Lützowplatz 15  
10785 Berlin

**Böblingen**

Agilent Technologies  
Deutschland GmbH  
Elektronische Messtechnik  
Herrenberger Str. 140  
71034 Böblingen

**Hamburg**

Agilent Technologies  
Deutschland GmbH  
Elektronische Messtechnik  
Überseering 16  
22297 Hamburg

**München**

Agilent Technologies  
Deutschland GmbH  
Elektronische Messtechnik  
Eschenstraße 5  
82024 Taufkirchen

**Ratingen**

Agilent Technologies  
Deutschland GmbH  
Elektronische Messtechnik  
Pempelfurt Straße 1  
40882 Ratingen

**Waldbronn (Karlsruhe)**

Agilent Technologies  
Deutschland GmbH  
Elektronische Messtechnik  
Hewlett-Packard-Str. 8  
76337 Waldbronn

**Ghana**

CIS Ghana  
P.O.Box 533  
ACCRA  
Tel: +233 21 242385  
Fax: +233 21 242140

**Greece**

All Assistance  
Tel: 30-175 64045  
Fax: 30-175 64020  
E-mail: mmylonas  
@g-systems.gr

G-Systems  
76, Ymittou Street  
11634 Athens

**Guinea**

RT21 (Paris, France)  
90-92 Rue Baudin  
92300 Levallois-Perret  
Tel: 33-1-41272222  
Fax: 33-1-41272223

Computer Information Systems  
Old Tripoli Road CIS Bldg.  
P.O. Box 11-6274  
Dora—Beirut 6274  
Lebanon  
Tel: +961 4 405 413  
Fax: +961 4 525 181  
E-mail: michel\_nassif  
@cis.com.lb

**Guinea Bissau**

Contact Agilent Technologies  
in Switzerland  
All Assistance  
Tel: +41 22 780 6136  
Fax: +41 22 780 69 22  
E-mail: marylin\_breux  
@agilent.com

**Hungary**

All Assistance  
Tel: +361 382 6006  
Fax: +361 382 6001  
E-mail: sandor.domokos  
@snt.hu

S&T Hungary  
Neumann Janos u.l.  
1117 Budapest

**Ireland**

All Assistance  
Tel: 1890 924204  
Fax: 01 205 4510  
E-mail: tmo\_assistance  
@agilent.com

Agilent Technologies Ireland  
Limited  
Stradbroke Road  
Blackrock,  
Co. Dublin

**Israel**

Assistance  
Tel: +972 3 6892 500  
Fax: +972 3 6892 501  
E-mail: liora\_mackmel  
@agilent.com

Training  
Tel: +972 3 6892 533  
Fax: +972 3 6892 548  
E-mail: efrat\_havusha  
@agilent.com

Agilent Technologies  
2, Hashlosha Street  
Building B3  
Tel-Aviv 67060

**Italy****Milan**

Product Selection, Purchase & Consulting  
Tel: 02 9260 8484  
Fax: 02 9210 4069  
E-mail: [agilent\\_direct@agilent.com](mailto:agilent_direct@agilent.com)

Equipment Service  
Tel: 02 9260 8329  
Fax: 02 9210 1757

Training  
Tel: +39 02 9260 8390

Cernusco s/N  
Agilent Technologies Italiana S.p.A.  
Via G. di Vittorio 9  
20063 Cernusco s/N  
Milan

**Roma Eur**

Agilent Technologies Italiana S.p.A.  
Viale del Tintoretto, 200  
00142 Roma Eur

**Ivory Coast**

CIS Cote d'Ivoire  
Immeuble Alpha 2000  
16eme etage  
P.O.Box 1361  
Abidjan 01  
Tel: +225-219216  
Fax: +225-219215

**Jordan**

All Assistance  
Tel: 9626 462 49 07  
Fax: 9626 462 82 58  
E-mail: [Saleh\\_Madhour@sms.nets.com.jo](mailto:Saleh_Madhour@sms.nets.com.jo)

Scientific & Medical Supplies Co.  
P.O. Box 1387  
Amman

**Kazakhstan**

All Assistance  
Tel: 7-3272-582020  
Fax: 7-3272-621843  
E-mail: [andrey\\_shiroky@cs.kz](mailto:andrey_shiroky@cs.kz)

COMPUTER SERVICE  
Karasat-Batyr Street 82  
Almaty 480012

**Kenya**

Concilium Technologies in South Africa  
Tel: 2711 444 8010  
Fax: 2711 444 8511  
E-mail: [info@concilium.co.za](mailto:info@concilium.co.za)

**Kuwait**

All Assistance  
Tel: +965 243 2555  
Fax: +965 243 1926  
E-mail: [najeeb@fcc-kuwait.com](mailto:najeeb@fcc-kuwait.com)

Future Communications Company W.L.L.  
Ahmed Al Jaber Street  
Al-Awadhi Towers - Tower 3 - 7th Floor  
Kuwait City, Kuwait

**Kyrgyzstan**

Computer Service, Kazakhstan  
Tel: 7-3272-582020  
Fax: 7-3272-621843  
E-mail: [andrey\\_shiroky@cs.kz](mailto:andrey_shiroky@cs.kz)

**Lebanon**

All Assistance  
Tel: +961 4 405 413  
Fax: +961 4 525 181  
E-mail: [michel\\_nassif@cis.com.lb](mailto:michel_nassif@cis.com.lb)

Computer Information Systems  
Jal El Dib Square CIS building  
P.O. Box 11-6274  
Dora- Beirut 6274

**Lesotho**

Concilium Technologies in South Africa  
Tel: 2711 444 8010  
Fax: 2711 444 8511  
E-mail: [info@concilium.co.za](mailto:info@concilium.co.za)

**Liberia**

Contact Agilent Technologies in Switzerland  
All Assistance  
Tel: +41 22 780 6136  
Fax: +41 22 780 69 22  
E-mail: [marylin\\_breux@agilent.com](mailto:marylin_breux@agilent.com)

**Luxembourg**

Agilent Technologies Belgium S.A./N.V.  
Product Selection & Purchase  
Tel: 32-2-778.34.13  
Fax: 32-2-778.34.14

Technical Support  
Tel: 32-2-778.59.50  
Fax: 32-2-778.59.51

Equipment Service  
Tel: 32-2-778.37.71  
Fax: 32-2-778.37.85

Training  
Tel: 32-2-778.34.13  
Fax: 32-2-778.34.14

**Former Yugoslav Republic of Macedonia**

All Assistance  
Tel: +389 91 117 790  
Fax: +389 91 127 072  
E-mail: [jovan.popovski@hermes-plus.com.mk](mailto:jovan.popovski@hermes-plus.com.mk)

Hermes Plus Dooel  
Gradski zid, Blok 5  
91000 Skopje

**Madagascar**

Handled by RT2I ( PARIS, France)  
90-92, Rue Baudin  
92300 Levallois-Perret  
Tel: +33-1 412 72222  
Fax: +33-1-412 72223  
E-mail: [michel\\_nassif@cis.com.lb](mailto:michel_nassif@cis.com.lb)

**Malawi**

Concilium Technologies, South Africa  
Tel: 2711 444 8010  
Fax: 2711 444 8511  
E-mail: [info@concilium.co.za](mailto:info@concilium.co.za)

**Mali**

Handled by CIS Ivory Coast

**Malta**

Tunisie Test et Mesure, Tunisia  
Tel: +216 1 237 123  
Fax: +216 1 235 048  
E-mail: [tunistest@planet.tn](mailto:tunistest@planet.tn)

**Mauritania**

Handled by CIS Ivory Coast

**Mauritius**

Concilium Technologies, South Africa  
Tel: 2711 444 8010  
Fax: 2711 444 8511  
E-mail: [info@concilium.co.za](mailto:info@concilium.co.za)

**Moldova, Republic of**

S&T Romania  
Tel: 0040-1-2040300  
Fax: +40 1 204 03 10  
E-mail: [lucian.dumitru@main.snt.ro](mailto:lucian.dumitru@main.snt.ro)

S&T Romania  
9-9A Dimitries Pompei Bvd- Sector 2  
Bucuresti

**Morocco**

All Assistance  
Tel: 212 231 2270  
Fax: 212 231 6545  
E-mail: [khouya@winner.net.ma](mailto:khouya@winner.net.ma)

Sicotel  
Complexe des Habous - Tour C, Avenue des Far  
Casablanca 01

**Mozambique**

Concilium Technologies, South Africa  
Tel: 2711 444 8010  
Fax: 2711 444 8511  
E-mail: [info@concilium.co.za](mailto:info@concilium.co.za)

**Namibia**

Concilium Technologies, South Africa  
Tel: 2711 444 8010  
Fax: 2711 444 8511  
E-mail: [info@concilium.co.za](mailto:info@concilium.co.za)

**Netherlands**

Product Selection, Purchase & Support  
Tel: 020-547 2211  
Fax: 020-547 2190  
E-mail: [customer-care\\_benelux@agilent.com](mailto:customer-care_benelux@agilent.com)

Equipment Service  
Tel: 020-547 2183  
Fax: 020-547 2191  
E-mail: [customer-care\\_benelux@agilent.com](mailto:customer-care_benelux@agilent.com)

Training  
Tel: 020-654 5563  
Fax: 020-654 5558  
E-mail: [customer-care\\_benelux@agilent.com](mailto:customer-care_benelux@agilent.com)

Agilent Technologies Netherlands B.V.  
Test & Measurement Startbaan 16  
1187 XR Amstelveen The Netherlands  
Tel: 020-547 2111  
Fax: 020-547 2190  
E-mail: [customer-care\\_benelux@agilent.com](mailto:customer-care_benelux@agilent.com)

**Niger**

Handled by CIS Ivory Coast

**Nigeria**

All Assistance  
Tel: 234 1 269 3421  
Fax: 234 1 269 3419  
E-mail: okon@mis.com.ng

Management Information Systems  
3, Gerrard Road  
P.O. Box 53386  
Lagos-Ikoyi

**Norway**

All Assistance  
Tel: 22 73 57 59  
Fax: 23 25 37 10  
E-mail: tm\_norway@agilent.com

Agilent Technologies Norge AS  
Drammensveien 169  
Postboks 60 Skøyen  
N-0212 OSLO  
Norway

**Oman**

All Assistance  
Tel: 968-70 7727  
Fax: 968-79 7709  
E-mail: parthasarathytn@imtac.com

IMTAC LLC  
Building 619, P.O. Box 196  
Postal Code 116-  
Wax No 2710 Salalah Building  
Muscat Greater Muttrah

**Poland**

All Assistance  
Tel: +48 22 6084555  
Fax: +48-22-6084554  
E-mail: pawel\_bachanek@am-tech.pl

AM Technologies Polska  
Aleje Jerozolimskie 181  
02-222 Warszawa

**Portugal**

Assistance  
Tel: (351/1) 482 8500  
Fax: (351/1) 441-7077

Instrument Repair & Calibration  
Fax: 800 403 0801

Agilent Technologies Portugal  
S.A.  
Quinta da Fonte  
Edificio Bartolomeu Dias  
Porto Salvo - 2780 Oeiras

**Qatar**

All Assistance  
Tel: 974-439 900  
Fax: 974-432 154  
E-mail: qds@qatar.net.qa

Qatar Datamation Systems  
Al-Ahed Building 5th floor,  
Al Muthaf Street  
Doha

**Reunion Island**

Contact Agilent Technologies  
in Switzerland  
All Assistance  
Tel: +41 22 780 6136  
Fax: +41 22 780 69 22  
E-mail: marylin\_breux@agilent.com

**Romania**

All Assistance  
Tel: 0040-1-2040300  
Fax: +40 1 204 03 10  
E-mail: lucian.dumitru@main.snt.ro

S&T Romania  
9-9A Dimitries Pompei Bvd -  
Sector 2  
Bucuresti

**Russia**

All Assistance  
Tel: +7-095-797 3928  
Fax: +7-095-797 3902  
E-mail: julia\_ovetchkina@agilent.com

Agilent Technologies Company  
Representative Office  
Kosmodamianskaya  
Naberezhnaya 52, Bldg. 1  
113054 Moscow

**Rwanda**

SOFITEC  
Face Grand Poste  
Kigali  
Tel: 250-75200  
Fax: 250-72735

**Saudi Arabia**

All Assistance  
Tel: 966-1-4624266 ext. 414  
Fax: 966-1-4624404  
E-mail: gbhat@Alfaisaliah.com

Al Faisaliah Medical &  
Measurement Systems Est.  
P.O. Box 22015  
Al Nemer building, Olaya street  
11495 Riyadh

**Senegal**

RTI Senegal  
150, ave. President Lamine  
Gueye  
P.O.Box 3716  
Dakar  
Tel: +221 222248  
Fax: +221 225178

**Sierra Leone**

Contact Agilent Technologies in  
Switzerland  
All Assistance  
Tel: +41 22 780 6136  
Fax: +41 22 780 69 22  
E-mail: marylin\_breux@agilent.com

**Slovak Republic**

All Assistance  
Tel: 421-769 258 111  
Fax: 421-769 259 212  
E-mail: emil\_vitek@snt.sk

S&T Slovakia  
Polianky C5  
Bratislava 84404

**Slovenia**

All Assistance  
Tel: 386-61-1895279  
Fax: 386-61-1895290  
E-mail: vitomir.podlogar@hermes-plus.si

Hermes Plus  
Slandrova 2  
1231 Ljubljana Cnuce

**South Africa**

All Assistance  
Tel: 2711 444 8010  
Fax: 2711 444 8511  
E-mail: info@concilium.co.za

Concilium Technologies  
9, Eastern Service Road  
Sandton

**Spain**

All Assistance  
Tel: 34 91 631.33.00  
Fax: 34 91 631.33.01

**Barcelona**

Agilent Technologies Spain, S.L.  
Avda. Diagonal, 605  
08028 Barcelona  
Tel: 34 93 401 91 00  
Fax: 34 93 430 84 68

**Bilbao**

Agilent Technologies Spain, S.L.  
Avda. de Zugazarte, 8  
Edif El Abra, 4  
48930 Las Arenas, Guecho  
Tel: 34 94 481 8000  
Fax: 34 94 481 8040

**Madrid**

Agilent Technologies Spain, S.L.  
Crta. N-VI km 18,200  
28230 Las Rozas, Madrid  
Tel: 34 91 631 3300  
Fax: 34 91 631 3301

**Swaziland**

Concilium Technologies, South  
Africa  
Tel: 2711 444 8010  
Fax: 2711 444 8511  
E-mail: info@concilium.co.za

**Sweden**

E-mail: agilent-direkt-se@agilent.com

Assistance  
Tel: (08) 506 486 86

Equipment Service  
Tel: (08) 506 487 00

Training  
Tel: (08) 506 487 11

Agilent Technologies Sweden AB  
Skalholtsgatan 9  
164 97 Kista  
Tel: (46/8) 444 22 77  
Fax: (46/8) 444 25 25

Agilent Technologies Sweden AB  
Vådursgatan 6  
Box 5328  
S-402 27 GÖTEBORG  
Sweden  
Tel: (46/31) 335 1800  
Fax: (46/31) 773 9742



**Switzerland**

All Assistance  
Tel: (01) 735 9300  
Fax: (01) 735 9301  
E-mail: messtechnik\_vertrieb@agilent.com

Service  
Tel: (01) 735 9501  
Fax: (01) 735 9511  
E-mail: ch\_messtechnik-service@agilent.com

**Geneva**

Agilent Technologies (Suisse) SA  
Elektronische Messtechnik 39,  
rue de Veyrot  
CH-1217 Meyrin 1  
Tel: (022) 780 6180  
Fax: (022) 780 6980

International Sales—Europe  
Agilent Technologies  
East Europe, Middle East/Africa  
Sales Branch  
Rue de Veyrot, 39  
P.O. Box 364  
1217 Meyrin 1  
Geneva  
Tel: +41 22 780 6136  
Fax: +41 22 780 69 22  
E-mail: marylin\_breux@agilent.com

**Zürich**

Agilent Technologies (Schweiz)  
AG  
Elektronische Messtechnik  
In der Luberzen 29  
8902 Urdorf/Zürich  
Tel: (01) 735 9300  
Fax: (01) 735 9301

**Tajikistan**

Contact Agilent Technologies  
in Switzerland  
All Assistance  
Tel: +41 22 780 6136  
Fax: +41 22 780 69 22  
E-mail: marylin\_breux@agilent.com

**Tanzania**

Concilium Technologies, South  
Africa  
Tel: 2711 444 8010  
Fax: 2711 444 8511  
E-mail: info@concilium.co.za

**Togo**

Handled by CIS Ivory Coast

**Tunisia**

All Assistance  
Tel: +216 1 237 123  
Fax: +216 1 235 048  
E-mail: tunitest@planet.tn

Tunisie Test et Mesure  
9, rue Mahmoud Bayram  
CP 1004 El Menzah 5  
Carnoy/Tunis

**Turkey**

All Assistance  
Tel: 90/312 468 87 70  
Fax: 90/312 468 87 78  
E-mail: ozlem\_sutlas@agilent.com

Agilent Technologies  
Olcum Sistemleri Ltd. Sti.  
Karum Ismerkezi No 461  
06680 Kavaklidere, Ankara

**Turkmenistan**

Contact Agilent Technologies  
in Switzerland  
All Assistance  
Tel: +41 22 780 6136  
Fax: +41 22 780 69 22  
E-mail: marylin\_breux@agilent.com

**Uganda**

Concilium Technologies, South  
Africa  
Tel: 2711 444 8010  
Fax: 2711 444 8511  
E-mail: info@concilium.co.za

**Ukraine**

Tel: +380 44 21 222 95  
Fax: +380 44 21 222 95  
E-mail: vitbut@unitest.kiev.ua

UNITEST LTD  
4/27 g. O. Honchara Street  
01025 KIEV

**United Arab Emirates**

Tel: +971 4 881 8055  
Fax: +971 4 881 8055  
E-mail: Abubakr\_Abuelazm@agilent.com

Gulf Branch Office  
Agilent Technologies  
P.O.Box 17669  
Jabbal Ali  
Dubai

Product Selection  
Tel: 971-4-282 7577  
Fax: 971-4-282 7836  
E-mail: Sunil\_Kumar@emitac.co.ae

Product Purchase & Technical  
Assistance  
Tel: +971 2 644 7420  
Fax: +971 2 644 2058  
E-mail: Manish\_Aggarwal@emitac.co.ae

Equipment Service  
Tel: +971 4 282 7577  
Fax: +971 4 282 7836  
E-mail: Kiran\_Anand@emitac.co.ae

Training  
Tel: +971 4 282 7577  
Fax: +971 2 644 7420

Emitac Ltd.  
Block B Arenco Building  
Zabel Road  
Dubai

**United Kingdom**

All Assistance  
Tel: 07004 666666

Agilent Technologies UK Limited  
Test & Measurement  
Eskdale Road  
Winnersh Triangle  
Wokingham  
Berkshire  
RG41 5DZ  
Tel: 07004 666666  
Fax: 07004 444555  
E-mail: tmo\_assistance@agilent.com

**Uzbekistan**

All Assistance  
Tel: 998-71-132 0871/4  
Fax: 998-71-120 6485  
E-mail: zakir.husain@abm.uz

ABM Worldwide Technologies  
13, Movaraunnakhr Street  
700047 Tashkent

**Zaire**

Contact Agilent Technologies  
in Switzerland  
All Assistance  
Tel: +41 22 780 6136  
Fax: +41 22 780 69 22  
E-mail: marylin\_breux@agilent.com

**Zambia**

Concilium Technologies, South  
Africa  
Tel: 2711 444 8010  
Fax: 2711 444 8511  
E-mail: info@concilium.co.za

**Zimbabwe**

Concilium Technologies, South  
Africa  
Tel: 2711 444 8010  
Fax: 2711 444 8511  
E-mail: info@concilium.co.za

## Agilent's web site: Get news, updated product and support information, and more, 24 hours a day.

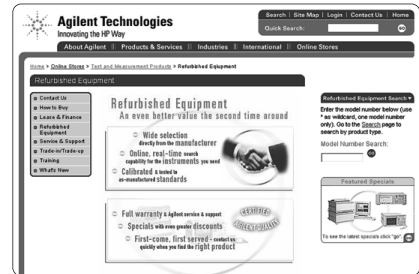
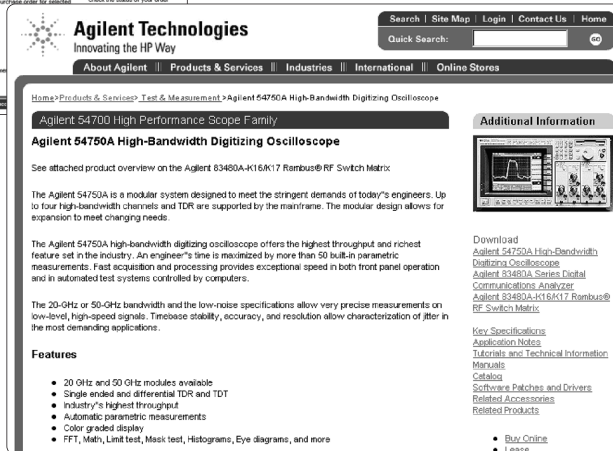

### Resources Available Online

- Product and support information more easily with helpful navigation aids and improved web pages that make it easier to access application notes, product overviews, technical details, frequently asked questions, manuals, software, news releases, education course descriptions and schedules, and much more.

- Updated comparison data and evaluation guides/tools that facilitate product selections
- Helpful application notes, downloadable interactive application notes, tutorials, online models, and other learning and problem-solving material
- Quick access to customer support services
- Information on recommended replacements for discontinued products
- Information in your local language\*
- The latest information on the status of your Agilent test and measurement order

### Take Action

- Selected Agilent products—including scopes, logic analyzers, EDA software, multimeters, data acquisition products, signal sources, counters, power supplies, and more\*
- Refurbished instruments\*
- Accessories\*
- Replacement parts\*

For more information on the test and measurement features, resources, and services available on Agilent's web site, see page 3.

Use our online test and measurement resources and services often!  
[www.agilent.com/find/tmc](http://www.agilent.com/find/tmc)

\*Availability of this feature may be limited; an expansion program is ongoing. Online purchases require a credit card.

For best results, view the Agilent web site with Microsoft's Internet Explorer browser.

Free Application Notes	576
Free Test & Measurement Specialty Catalogs	599
Free T&M Quarterly Newsletters	602
Technical Handbooks Available Through McGraw-Hill	603
Call Centers	604

**Application Notes**

Agilent Technologies has an extensive library of both hardcopy and on-line application information. A listing of test and measurement application notes begins on this page.

*Application Notes* help solve your measurement, computation, and design problems. They offer the benefit of the applications research and experience of both Agilent customers and Agilent engineers. Some of these application notes are tutorial, others describe how-to procedures.

**How to Order**

To obtain a free copy of any of the Application Notes listed here and on the following pages, contact the Agilent Call Center in your region. For Outside the U.S. see inside back cover. Within the United States, call (800) 452-4844 and provide the Agilent customer service representative with the nine-digit literature number for each Application Note requested. Please limit your orders to five Application Notes per phone call.

Many of the most current Application Notes are also down loadable directly from the Test & Measurement area of Agilent's web site:  
[www.agilent.com/find/apps](http://www.agilent.com/find/apps)

**3G Solutions**

- Challenges in developing the deploying 3G systems  
[5980-1223E](#)
- Designing and Testing 3GPP W-CDMA Base Stations (BS) (AN 1355)  
[5980-1239E](#)
- Designing and Testing 3GPP W-CDMA User Equipment (UE) (AN 1356)  
[5980-1238E](#)
- Designing and Testing cdma2000 Base Stations (AN 1357)  
[5980-1303E](#)
- Designing and Testing cdma2000 Mobile Stations (AN 1358)  
[5980-1237E](#)
- HPSK Spreading for 3G  
[5968-8438E](#)
- Measurements On Digital Modulation Components Requiring A Complex Stimulus (AN 1353)  
[5980-1337E](#)
- Performing cdma2000 Measurements Today  
[5968-5858E](#)

**Amplifiers**

- Complete Analysis of Erbium-Doped Fiber Amplifiers  
[5965-0976E](#)
- Generating Custom, Real-World Waveforms (AN 1360)  
[5980-2518EN](#)
- How to Characterize CATV Amplifiers Effectively (AN 1288-4)  
[5965-9434E](#)
- Testing Amplifiers and Active Devices with the Agilent 8510 Network Analyzer  
[55963-2352E](#)
- Amplifier Measurements Using the Scalar Network Analyzer (AN 345-1)  
[5954-1599](#)
- Extending Dynamic Range of Scalar Transmission Measurements Using the Agilent 8757A, 8756A, or 8755C Scalar Network Analyzers (AN 327-1)  
[5953-8882](#)
- Measuring EDGE Signals—New and Modified Techniques and Measurement Requirements (AN 1361)  
[5980-2508EN](#)
- Noise Figure Measurement Accuracy (AN 57-2)  
[5952-3706](#)
- Practical Noise Figure Measurement and Analysis for Low-Noise Amplifier Designs (AN 1354)  
[5980-1916E](#)
- S-Parameter Techniques for Faster, More Accurate Network Design (AN 95-1)  
[5952-1130](#)

**Amplitude Modulation**

- Spectrum Analysis AM and FM (AN 150-1)  
[5954-9130](#)



**Audio**

Basic Operation & Application Guide Agilent 8904A Operation Made Easy (AN 8904A)  
5953-8491

**Aviation/Transportation**

Agilent TS-5400 Series II Remote Keyless Entry Application  
5968-6080E

Agilent TS-5400 Series II Supplemental Restraint Systems  
5968-6356E

93 TS5400 Series II Antilock Brakes & Traction Control Application  
5968-6079E

VOR/ILS Testing with Agilent 8644A (AN 8644-2)  
5951-6740

**Battery Testing**

Battery Charging/Discharging (AN 250-2)  
5952-4033

**Board Test**

A Quality Test Demands A Quality Fixture  
5965-6624E

Connect Check Backgrounder  
5965-5092E

Vectorless Test Purchaser's Guide  
5965-0805E

**CAE**

10 Hints for Making Successful Noise Figure Measurements (AN 1341)  
5980-0288E

Generating Custom, Real-World Waveforms (AN 1360)  
5980-2518EN

Hierarchical Modeling for Circuit Characterization (AN 1201-2)  
5091-1668E

Measuring EDGE Signals—New and Modified Techniques and Measurement Requirements (AN 1361)  
5980-2508EN

Practical Noise Figure Measurement and Analysis for Low-Noise Amplifier Designs (AN 1354)  
5980-1916E

**Cable Measurements**

Balanced Circuit Measurement with an Impedance Analyzer/LCR Meter/Network Analyzer (AN 346-2)  
5091-4480E

How to Characterize CATV Amplifiers Effectively (AN 1288-4)  
5965-9434E

Measuring the Characteristic Impedance of Balanced Cables (AN 339-4)  
5950-2918

**Calibration**

Applying Error Correction to Network Analyzer Measurements (AN 1287-3)  
5965-7709E

Noise, Figure Measurement Accuracy (AN 57-2)  
5952-3706

Signal Generator (AN 388)  
5952-2019

**Compliance Testing**

Compliance Testing to the IEC 1000-3-2 and (EN 61000-3-2) and IEC 1000-3-3 (EN 61000-3-3) Standards (AN 1273)  
5964-1917E

Compliance Testing IEC/EN 61000-4-8 (AN 1319)  
5968-3730E

Conformance Testing—An Essential Part of SDH Deployment  
5965-1020E

Conformance Testing and Essential Part of SONET Deployment  
5965-1432E

Cookbook for EMC Precompliance Measurements (AN 1328)  
5968-3661E

**Component Test**

A Guideline for Designing External DC Bias Circuits (AN 346)  
5950-2912

ABR Technology Overview and Testing Challenges  
5968-1234E

Accurate and Effective Flash Memory Cell Evaluation Using the Agilent 4072A  
5968-6719E

Accurate and Efficient C-V Measurements (AN E5250A-3)  
5965-5658E

Agilent Technologies ParBERT 81250, Mux/Demux Application  
5968-9695E

Agilent VXI Test System Signal Switching  
5968-7234E

Automated Characterization of Microwave VCOs Using the Agilent 5361A/B Pulse/CW Microwave Counter (AN 377-2)  
5952-7988

Automated Extraction of Semiconductor Parameters using the Agilent 4155B/4156B  
5963-1249E

Automatic Frequency Settling Time Measurement Speeds Time-to-Market for RF Designs  
5964-4335E

Balanced Circuit Measurement with an Impedance Analyzer/LCR Meter/Network Analyzer (AN 346-2)  
5091-4480E

Biasing Three-Terminal Devices for Test (AN 376-1)  
5952-4193

Characterizing Communications ICs With The Agilent 83000 Model F660  
5962-9273EUS

Characterizing Components with a Microwave Tracking Source (AN 1212)  
5091-2172E

Characterizing High-Speed Optical Transmitters Compliance Testing with the Agilent 86100A Infiniium DCS (AN 1340-1)  
5968-9249E

Combining Network and Spectrum Analysis and IBASIC to Improve Device Characterization and Time Set  
5965-7656E

Characterizing Digitally Modulated Signals with CCDF Curves  
5968-6875E

Contact Resistance and Insulation Resistance Measurements of Electro-mechanical Components (AN 1305-1)  
5968-0325

Effective Electrolytic Capacitors Testing  
5967-5378E

Effective Multitap Transformer Testing Using a Scanner (AN 1239)  
5091-6310E

Effective Transformer/LF Coil Testing (AN 1305-3)  
5967-5377E

Evaluating Chip Inductors Using the Agilent 4291B  
5966-1848

Evaluation of Flash Memory Cells (AN 4156-4)  
5965-5657E

Evaluation of Hot Carrier Induced Degradation of MOSFET Devices (AN 4156-3)  
5963-1111E

High Accuracy and Fast RF Inductor Testing (AN 369-10)  
5091-1596E

High Accuracy and Fast RF Inductor Testing (AN 369-10)  
5091-1596E

Many of these documents are orderable and downloadable from Agilent's web site:

[www.agilent.com/find/apps](http://www.agilent.com/find/apps)

High-Speed Lightwave Component Analysis  
(AN 1550-6)

[5091-6478E](#)

Highly Accurate Evaluation of Chip Capacitors  
using the Agilent 4291B

[5966-1850E](#)

GPIB Programming Hints for the Agilent 4194A  
(AN 339-12)

[5950-2929](#)

Impedance Characterization of Resonators  
Using the Agilent 4194A Impedance/  
Gain-Phase Analyzer (AN 339-1)

[5950-2882](#)

Impedance Measurement for Incoming  
Inspection—Agilent 4284A Application  
Information (AN 369-4)

[5950-2952](#)

Impedance Measurements...in Brief

[5964-3558E](#)

Impedance Testing Using a Scanner (AN 369-6)

[5950-2975](#)

Improve Electronic Product Quality and  
Performance with Agilent Precision LCR  
Meters (AN 369-9)

[5090-0233](#)

In-Depth Characterization of Optical Components

[5965-5286E](#)

In-Fixture Measurements Using Vector Network  
Analyzers (AN 1287-9)

[5968-5329E](#)

Making Radiated and Conducted Compliance  
Measurements with EMI Receivers  
(AN 1302)

[5966-2915E](#)

Maximizing the Incoming Inspection Efficiency  
of Semiconductor Devices (AN 4156-6)

[5963-2364E](#)

Measurement of Capacitance Characteristics of  
Liquid Crystal Cell (AN 369-7)

[5950-2994](#)

Measurement of Impedance of Magnetic Head  
(AN 369-12)

[5965-6663E](#)

Measurement of Power Devices Using External  
DC Power Supply (AN 4156-5)

[5963-2365E](#)

Measuring Characteristic Impedance of Short  
Rambus Motherboard Traces and Small-  
Outline RIMMs (AN 1304-4)

[5968-9146E](#)

Memory Test Software Provides Cost-Effective  
Solutions to Testing Advanced SRAMs

[5963-5078E](#)

Multifrequency C-V Measurements of  
Semiconductors—Agilent 4284A Application  
Information (AN 369-5)

[5950-2953](#)

Network Analyzer Measurements: Filter and  
Amplifier Examples (AN 1287-4)

[5965-7710E](#)

Network, Spectrum, and Impedance Evaluation  
of Electronic Circuits and Components  
(AN 1308-1)

[5967-5942E](#)

Network, Spectrum, and Impedance Evaluation  
of IF Circuits—Agilent 4195A  
Network/Spectrum Analyzer (AN 357-1)

[5950-2931](#)

Optimizing VCO/PLL Evaluations and  
PLL Synthesizer Designs

[5968-6772E](#)

POS Router Latency Testing

[5968-9724E](#)

Pulsed Measurements with the Agilent 8720ES  
and 8753ES Network Analyzers (AN 1287-10)

[5980-0798E](#)

Reducing Process Defect Escapes with  
Vectorless Test

[5965-5092E](#)

Segmentation: A Technique for Adapting the  
Agilent83000 Model F660 to Test High-SEMI  
S2 Standard Modifications for Agilent 3070  
and Related Equipment

[5980-0941E](#)

Simplified Analysis of Phase-Locked Loop  
Capture and Tracking Range (AN 1200-7)

[5966-4480E](#)

Simplified Filter Tuning Using Time Domain  
(AN 1287-8)

[5968-5328E](#)

Testing Amplifiers and Active Devices with the  
Agilent 8510 Network Analyzer

[5963-2352E](#)

Ultra Low Current DC Characterization of  
MOSFETs at the Wafer Level (AN 4156-1)

[5963-2014E](#)

Using Impedance Measurement to Evaluate  
Electronic Components and Materials—  
Agilent 4284A Application Information  
(AN 369-1)

[5950-2949](#)

Verifying and Evaluating Gigabit Switch/Routers  
Performance with Internet-Scale Simulation

[5968-1233E](#)

Wide-Range DC Current Biased Inductance  
Measurement (AN 369-8)

[5950-2367](#)

## Computers & Peripherals

Quick Identification of Periodic Jitter Sources  
(AN 1200-4)

[5966-4477E](#)

## Crystal Filters

Efficient Evaluation of LISNs and Voltage Probes  
for EMI Tests Using the Agilent 4194A  
(AN 339-7)

[5950-2922](#)

Filter Test for Production and Incoming  
Inspection: Agilent 4194A Impedance  
Gain-Phase Analyzer (AN 339-11)

[5952-7887](#)

## Crystals

Fundamentals of Quartz Oscillators (AN 200-2)

[5965-7662E](#)

Practical Design and Evaluation of High-  
Frequency Circuits (AN 317)

[5953-6910](#)

## Data Acquisition

Practical Strain Gauge Measurements (AN 290-1)

[5952-8880](#)

## Data Communications

10/100 Base-T Testing

[5968-5053E](#)

1609/07A ATM Stream Processor

[5968-6561E](#)

ABR Technology Overview and Testing  
Challenges

[5968-1234E](#)

ABR Technology Overview and Testing  
Challenges

[5968-1234E](#)

Advanced Testing Techniques for ATM Service  
Level Agreements

[5968-6560E](#)

Agilent Technologies ParBERT 81250,  
Mux/Demux Application

[5968-9695E](#)

- An Introduction to Error Location Analysis (AN 1550-2)  
[5980-0648E](#)
- ATM Forum European Update  
[5964-4147E](#)
- Basic ATM Troubleshooting with the Agilent Internet Advisor  
[5968-5924E](#)
- Conformance Testing—An Essential Part of SDH Deployment  
[5965-1020E](#)
- Conformance Testing and Essential Part of SONET Deployment  
[5965-1432E](#)
- Connecting Agilent Test Sets for In-Service Testing of PDH/SDH Networks  
[5965-5898E](#)
- Designing Packet over SONET/SDH (POS) Hardware  
[5968-1614E](#)
- Digital Radio Theory and Measurements (AN 355A)  
[5091-4777E](#)
- DS3 Network Interface Unit (AN 1)  
[5963-9927EUS](#)
- Dual Simultaneous Measurements (AN 1346)  
[5980-0547E](#)
- Ethernet/Fast Ethernet Problems and Solutions (AN 1336)  
[5968-8428E](#)
- Fast Characterization of Pulse-Width Encoded Data (AN 1200-5)  
[5966-4478E](#)
- Frequency Agile Jitter Measurement System (AN 1267)  
[5963-5353E](#)
- Functional Testing of ATM Signaling Protocols  
[5965-9331E](#)
- High-Speed BER Testing of SDH Components and Sub-Systems  
[5091-4799E](#)
- Histograms Simplify Analysis of Random Jitter (AN 1200-9)  
[5966-4482E](#)
- Agilent Internet Advisor Troubleshooting Frame Relay (AN 1323)  
[5968-5310E](#)
- Implementing ATM Signaling: Avoiding the Interoperability Pitfalls  
[5963-7514E](#)
- Internet Protocol Quality of Service  
[5968-9722E](#)
- Internet Routing Protocol Testing  
[5968-9391E](#)
- Locating Errors in Gigabit Transmission Systems and Components  
[5963-2005E](#)
- Maximizing Revenue with In-Service Testing—Centralized Testing/Monitoring Systems (AN 1237-2)  
[5091-6349E](#)
- Mixing MPEG-II & ATM: Will It work?  
[5963-7511E](#)
- Multi Protocol Label Switching  
[5980-1225E](#)
- NNI Signaling Test Software Helps Ensure Seamless ATM Networks  
[5965-6307E](#)
- Operating LANs in an ATM Environment  
[5963-7513E](#)
- POS Router Latency Testing  
[5968-9724E](#)
- Quick Identification of Periodic Jitter Sources (AN 1200-4)  
[5966-4477E](#)
- Signaling Performance Case Studies using the Multiport UNI Signaling Performance Test Solution  
[5968-1235E](#)
- Simple Analysis of Frequency Modulation (AN 1200-6)  
[5966-4479E](#)
- Simplified Analysis of Phase-Locked Loop Capture and Tracking Range (AN 1200-7)  
[5966-4480E](#)
- Testing ATM at 622 Mb/s and above  
[5965-9333E](#)
- Testing ATM Signaling Performance  
[5965-9330E](#)
- Testing for GFR QoS Eligibility and Frame-based Statistics  
[5980-0565E](#)
- Testing QoS, OAM, Policing, and Performance at 622 Mb/s and 2.4 Gb/s  
[5968-1237E](#)
- Testing Standard and CRC-4 2.048 Mb/s Systems (AN 1321)  
[5968-4518E](#)
- Testing Techniques for Next Generation IP Networks  
[5968-1236E](#)
- Testing to Ensure Your P-NNI Implementation is Ready to Plug-and-Play  
[5966-1004E](#)
- Traffic Policing  
[5963-7510E](#)
- Troubleshooting Frame Relay (AN 1323)  
[5968-5310E](#)
- True Router Performance Testing  
[5980-1421E](#)
- VCO Step Response Analysis Made Easy (AN 1200-3)  
[5966-4476E](#)
- Verifying and Evaluating Gigabit Switch/Routers Performance with Internet-Scale Simulation  
[5968-1233E](#)
- WAN Interworking with ATM  
[5963-7512E](#)
- What is Route Convergence?  
[5980-1224E](#)
- What is Routing Instability?  
[5980-1226E](#)

## Data Converters

- The Dynamic Range Benefits of Large Scale Dithered Analog-to-Digital Conversion in the Agilent 89410A and 89440A  
[5091-7668E](#)
- 10-Megasample-per-Second Analog-to-Digital Converter with Filter and memory/Agilent E1430A  
[5962-9497E](#)

## Digital Communications

- ATM Forum European Update  
[5964-4147E](#)
- Automatic Frequency Settling Time Measurement Speeds Time-to-Market for RF Designs  
[5964-4335E](#)
- CDPD Testing—Agilent 8921A Option 502/3 or 602/3  
[5965-5187E](#)
- Conformance Testing—An Essential Part of SDH Deployment  
[5965-1020E](#)
- Conformance Testing and Essential Part of SONET Deployment  
[5965-1432E](#)
- Digital Modulation in Connection Systems—An Introduction  
[5965-7160E](#)
- Digital Radio Theory and Measurements (AN 355A)  
[5091-4777E](#)
- DS3 Network Interface Unit (AN 1)  
[5963-9927EUS](#)
- Evaluating Tributary Jitter from the SDH Network (AN 1258)  
[5962-9551E](#)
- Examine Channel Switching Characteristics of Cellular Radios (AN 1200-10)  
[5966-4483E](#)
- Getting the Most Out of Your T1 and DDS Services  
[5091-6174E](#)
- High Productivity Measurements in Digital, Transmission (AN 387)  
[5959-7898](#)
- High-Speed BER Testing of SDH Components and Sub-Systems  
[5091-4799E](#)
- Implementing ATM Signaling: Avoiding the Interoperability Pitfalls  
[5963-7514E](#)

Measuring Demodulator Image Rejection  
Using the Agilent 8980A Vector Analyzer  
(AN 1200-7)  
[5952-3703](#)

Measuring Microwave Radio Antenna Return  
Loss Using the Agilent 11758T Digital Radio  
Test System (AN 379-2)  
[5959-8749](#)

Operating LANs in an ATM Environment  
[5963-7513E](#)

Testing & Troubleshooting Digital RF  
Communications Receiver Designs  
(AN 1314)  
[5968-3579E](#)

Testing and Troubleshooting Digital RF  
Communications Transmitter Designs  
(AN 1313)  
[5968-3578E](#)

Testing Digital MW Receivers with a Calibrated  
Source (AN 343-6)  
[5952-0800](#)

Traffic Policing  
[5963-7510E](#)

WAN Interworking with ATM  
[5963-7512E](#)

### Digital Data Transmission

Characterizing Digitally Modulated Signals with  
CCDF Curves  
[5968-6875E](#)

Connecting Agilent Technologies Test Sets for In-  
Service Testing of PDH/SDH Networks  
[5965-5898E](#)

Testing ATM at 622 Mb/s and above  
[5965-9333E](#)

Testing ATM Interoperability  
[5965-9334E](#)

Testing ATM Signaling Performance  
[5965-9330E](#)

Testing for GFR QoS Eligibility and Frame-based  
Statistics  
[5980-0565E](#)

Testing Operation and Maintenance (OAM)  
Implementations for ATM  
[5965-9332E](#)

Testing N x 64 kb/s Services (AN 1211-2)  
[5091-2069E](#)

Testing Sub-rate Data Services (AN 1211-3)  
[5091-2072E](#)

The Quest for Quality: The ATM Impairment  
Testing Handbook  
[5965-4992E](#)

### Disk Drive Test

Bearing Runout Measurements (AN 243-7)  
[5965-5387E](#)

Component Test (AN 369-3)  
[5950-2951](#)

Impedance Characterization of Magneto-  
Resistive Disk Heads (AN 1300-6)  
[5966-1096E](#)

Measurement of Impedance of Magnetic Head  
(AN 369-12)  
[5965-6663E](#)

Synthesizing Magnetic Disk Read and Servo  
Signals with Agilent 8770A Arbitrary  
Waveform System (AN 314-2)  
[5954-6357](#)

### Distortion

Eight Hints for Making Better Spectrum Analyzer  
Measurements  
[5965-7009E](#)

Non-Contact Measurements with Laser  
Interferometers (AN 325-12)  
[5966-1989E](#)

Optimizing Spectrum Analyzer Dynamic Range  
[5968-4545E](#)

### ECM/ECCM

Simplified Analysis of Phase-Locked Loop  
Capture and Tracking Range (AN 1200-7)  
[5966-4480 E](#)

Single Shot Frequency Profiling of Chirped  
Radars Made Easy (AN 1200-8)  
[5966-4481 E](#)

### EMI/EMC

Cookbook for EMC Precompliance  
Measurements (AN 1328)  
[5968-3661E](#)

Cookbook for EMC Precompliance  
Measurements (AN 1290-1)  
[5964-2151E](#)

Making Radiated and Conducted Compliance  
Measurements with EMI Receivers  
(AN 1302)  
[5966-2915E](#)

### Electronic Warfare (EW)

Automatic Frequency Profiling of Chirped Radar  
Pulses Using the Agilent 5361A/B Pulse/  
CW Microwave Counter (AN 377-1)  
[5952-7987](#)

Practical Strain Gauge Measurements  
(AN 290-1)  
[5952-8880](#)

Single Shot Frequency Profiling of Chirped  
Radars Made Easy (AN 1200-8)  
[5966-4481 E](#)

Vector Modulation Measurements/Coherent  
Pulsed Tests of Radar and EW Systems  
(AN 043-3)  
[5954-6366](#)

### Fiber Optics

Beginner's Guide to Using the Agilent 8147  
Optical Time Domain Reflectometer  
[5964-6672E](#)

Conformance Testing—An Essential Part of  
SDH Deployment  
[5965-1020E](#)

Conformance Testing and Essential Part of  
SONET Deployment  
[5965-1432E](#)

Frequency Agile Jitter Measurement System  
(AN 1267)  
[5963-5353E](#)

High-Speed BER Testing of SDH Components  
and Sub-Systems  
[5091-4799E](#)

High-Speed Lightwave Component Analysis  
(AN 1550-6)  
[5091-6478E](#)

Lightwave Measurements with the Agilent  
71400 Lightwave Signal Analyzer (AN 371)  
[5954-9137E](#)

Locating Errors in Gigabit Transmission Systems  
and Components  
[5963-2005E](#)

Pulse Testing 980-nm Pump Laser-Diodes in  
Optical Fiber  
[5963-6988E](#)

### Fourier Analysis

Control System Measurement Fundamentals  
Using Dynamic Signal Analyzers and  
Non-Contact Measurements with Laser  
Interferometers (AN 325-12)  
[5966-1989E](#)

Precision Time-Domain Measurement Using  
the Agilent E1430A  
[5962-0015E](#)

### Frequency

Accurate and Efficient Frequency Evaluation of a  
Ring Oscillator (AN 4070-3)  
[5968-4310E](#)

Examine GMSK Modulation in GSM and  
PCN Mobile Communications Systems  
(AN 1200-11)  
[5965-9650E](#)

Fundamentals of Microwave Frequency  
Counters (AN 200-1)  
[5965-7661E](#)

Fundamentals of the Electronic Counters  
[5965-7660E](#)



- Improving Network Analyzer Measurements of Frequency-Translating Devices (AN 1287-7)  
5966-3318E
- Signal Generator (AN 388)  
5952-2019
- Single Shot Frequency Profiling of Chirped Radars Made Easy (AN 1200-8)  
5966-4481 E
- Understanding Frequency Counter Specifications (AN 200-4)  
5965-7664E

### Frequency Modulation

- Automatic Frequency Settling Time Measurement Speeds Time-to-Market for RF Designs  
5964-4335E
- Examine GMSK Modulation in GSM and PCN Mobile Communications Systems (AN 1200-11)  
5965-9650E
- Peak Deviation and Center Frequency Measurements for CT2 and DECT Radios (AN 1200-12)  
5966-4484 E
- Simple Analysis of Frequency Modulation (AN 1200-6)  
5966-4479 E
- Spectrum Analysis AM and FM (AN 150-1)  
5954-9130
- Spectrum Analyzer Basics (AN 150)  
5952-0292

### Frequency Stability—Short-Term

- Fundamentals of Microwave Frequency Counters (AN 200-1)  
5965-7661E
- Histograms Simplify Analysis of Random Jitter (AN 1200-9)  
5966-4482 E
- Quick Identification of Periodic Jitter Sources (AN 1200-4)  
5966-4477 E
- Signal Generator (AN 388)  
5952-2019

### Frequency Synthesizers

- Automated Characterization of Microwave VCOs Using the Agilent 5361A/B Pulse/CW Microwave Counter (AN 377-2)  
5952-7988
- Examine Channel Switching Characteristics of Cellular Radios (AN 1200-10)  
5966-4483 E

- External Frequency Doubling of the Agilent 8662A Synthesized Signal Generator (AN 283-2)  
5952-8217
- Signal Generator (AN 388)  
5952-2019
- Simplified Analysis of Phase-Locked Loop Capture and Tracking Range (AN 1200-7)  
5966-4480 E
- VCO Step Response Analysis Made Easy (AN 1200-3)  
5966-4476 E

### Group Delay

- Floating Measurements and Guarding (AN 123)  
5952-2153

### IC Testing

- Accurate and Effective Flash Memory Cell Evaluation Using the Agilent 4072A  
5968-6719E
- Automated Extraction of Semiconductor Parameters Using the Agilent 4155B/4156B  
5963-1249E
- Electronic Characterization of IC Package (AN 1300-5)  
5966-1849E
- Histograms Simplify Analysis of Random Jitter (AN 1200-9)  
5966-4482 E
- Low Current Measurement with Agilent E5250A Switch Mainframe (AN E5250A-1)  
5964-9112E
- On-Chip Semiconductor Device Impedance Measurements Using the Agilent 4291B (AN 1300-7)  
5966-1845E
- Pulsed Characteristics of Power Semiconductors Using Electronic Loads (AN 1246)  
5091-7636E
- Quick Identification of Periodic Jitter Sources (AN 1200-4)  
5966-4477 E
- SEMI S2 Standard Modifications for Agilent 3070 and Related Equipment  
5980-0941E

### Impedance

- A Guideline for Designing External DC Bias Circuits (AN 346)  
5950-2912
- Accurate Capacitance Characterization at the Wafer Level (AN 4070-2)  
5968-2499E
- Balanced Circuit Measurement with an Impedance Analyzer/LCR Meter/Network Analyzer (AN 346-2)  
5091-4480E
- Basics of Measuring the Dielectric Properties of Materials (AN 1217-1)  
5091-3300E
- Component Test (AN 369-3)  
5950-2951
- Contact Resistance and Insulation Resistance Measurements of Electro-mechanical Components (AN 1305-1)  
5968-0325
- Dielectric and magnetic Material Characterization with the Novocontrol Concept 60 System (AN 1300-8)  
5968-4491E
- Dynamic Component Test Using Vector Modulation Analysis (AN 343-2)  
5954-6367
- Effective Electrolytic Capacitors Testing  
5967-5378E
- Effective Impedance Measurement Using OPEN/SHORT/LOAD Correction (AN 346-3)  
5091-6553E
- Effective Transformer/LF Coil Testing (AN 1305-3)  
5967-5377E
- Electronic Characterization of IC Package (AN 1300-5)  
5966-1849E
- Evaluating Chip Inductors Using the Agilent 4291B  
5966-1848
- Evaluating Microstrip with Time Domain Reflectometry (AN 1304-1)  
5968-0007E
- Highly Accurate Evaluation of Chip Capacitors using the Agilent 4291B  
5966-1850E
- 8 Hints for Successful Impedance Measurement (AN 346-4)  
5968-1947E
- Impedance Characterization of Magneto-Resistive Disk Heads (AN 1300-6)  
5966-1096E

Impedance Measurement for Incoming Inspection—Agilent 4284A Application Information (AN 369-4)  
[5950-2952](#)

Impedance Measurements...in Brief  
[5964-3558E](#)

Impedance Testing Using a Scanner with the Agilent 54120 Family of Digitizing Oscilloscopes (AN 369-6)  
[5950-2975](#)

Improve Electronic Product Quality and Performance with Agilent Precision LCR Meters (AN 369-9)  
[5090-0233](#)

Measurement of Capacitance Characteristics of Liquid Crystal Cell (AN 369-7)  
[5950-2994](#)

Measuring the Characteristic Impedance of Balanced Cables (AN 339-4)  
[5950-2918](#)

Measuring Characteristic Impedance of Short Rambus Motherboard Traces and Small-Outline RIMMs (AN 1304-4)  
[5968-9146E](#)

Microprobing with the Agilent 54750 Oscilloscope (AN 1304-3)  
[5968-0773E](#)

Network, Spectrum, and Impedance Evaluation of Electronic Circuits and Components (AN 1308-1)  
[5967-5942E](#)

Network, Spectrum, and Impedance Evaluation of IF Circuits: Agilent 4195A Network/Spectrum Analyzer  
[5950-2931](#)

On-Chip Semiconductor Device Impedance Measurements Using the Agilent 4291B (AN 1300-7)  
[5966-1845E](#)

Permeability Measurements Using the Agilent 4291B and Agilent 1654A (AN 1300-4)  
[5966-1844E](#)

Permittivity Measurements of PC Board and Substrate Materials Using the Agilent 4291B and Agilent 16453A (AN 1300-3)  
[5966-1847E](#)

Practical Design and Evaluation of High-Frequency Circuits (AN 317)  
[5953-6910](#)

Time Domain Reflectometry Theory (AN 1304-2)  
[5966-4855E](#)

Using Impedance Measurement to Evaluate Electronic Components and Materials: Agilent 4284A Application Information (AN 89-1)  
[5950-2949](#)

Wide-Range DC Current Biased Inductance Measurement (AN 369-8)  
[5950-2367](#)

### Insertion Gain/Loss

Balanced Circuit Measurement with an Impedance Analyzer/LCR Meter/Network Analyzer (AN 346-2)  
[5091-4480E](#)

Noise, Figure Measurement Accuracy (AN 57-2)  
[5952-3706](#)

### Interface Bus ( GPIB )

Fast Characterization of Pulse-Width Encoded Data (AN 1200-5)  
[5966-4478 E](#)

### Internet

Designing Packet over SONET/SDH (POS) Hardware  
[5968-1614E](#)

Agilent Internet Advisor Troubleshooting Frame Relay (AN 1323)  
[5968-5310E](#)

Agilent Internet Advisor Troubleshooting VoIP Signaling (AN 1320)  
[5968-4450E](#)

Agilent NetMatrix RMON2 Delivered through Agilent NetMatrix Solutions (AN 1283)  
[5965-7597E](#)

Riding the Internet Wave: Ensuring Safe, Solid Internet Services for the Enterprise (AN 1295)  
[5965-9371E](#)

Testing Techniques for Next Generation IP Networks  
[5968-1236E](#)

The Quest of Quality: The ATM Impairment Testing Handbook  
[5965-4992E](#)

### Jitter

Evaluating Tributary Jitter from the SDH Network (AN 1258)  
[5962-9551E](#)

Frequency Agile Jitter Measurement System (AN 1267)  
[5963-5353E](#)

Fundamentals of Time Interval Measurements (AN 200-3)  
[5965-7663](#)

Histograms Simplify Analysis of Random Jitter (AN 1200-9)  
[5966-4482 E](#)

Signal Generator (AN 388)  
[5952-2019](#)

### Laser Interferometers

Disk Drive Servo-Track Writing with Laser Interferometers (AN 325-11)  
[5952-7984](#)

Non-Contact Measurements with Laser Interferometers (AN 325-12)  
[5966-1989E](#)

Submicron Positioning with the Agilent 5527A Laser Position Transducer System and Agilent 10936A Servo-Axis Board (AN 325-10)  
[5952-7942](#)

### Lightwave

Beginner's Guide to Using the Agilent 8147 Optical Time Domain Reflectometer  
[5964-6672E](#)

Characterizing High-Speed Optical Transmitters Compliance Testing with the Agilent 86100A Infinium DCS (AN 1340-1)  
[5968-9249E](#)

Complete Analysis of Erbium-Doped Fiber Amplifiers  
[5965-0976E](#)

Designing Packet over SONET/SDH (POS) Hardware  
[5968-1614E](#)

Evaluating Tributary Jitter from the SDH Network (AN 1258)  
[5962-9551E](#)

Frequency Agile Jitter Measurement System (AN 1267)  
[5963-5353E](#)

High-Speed Lightwave Component Analysis (AN 1550-6)  
[5091-6478E](#)

In-Depth Characterization of Optical Components  
[5965-5286E](#)

Introduction to BER Testing of WDM Systems (AN 1299)  
[5966-0911E](#)

Lightwave Measurements with the Agilent 71400 Lightwave Signal Analyzer (AN 371)  
[5954-9137E](#)

Locating Errors in Gigabit Transmission Systems and Components  
[5963-2005E](#)

Measuring Extinction Ratio of Optical Transmitters (AN 1550-8)  
[5966-4316E](#)

Optical Spectrum Analysis Basics  
[5963-7145E](#)

Pulse Testing 980-nm Pump Laser-Diodes in Optical Fiber  
[5963-6988E](#)

**Logic Analysis/Logic Analyzers**

- 8 Hints for Solving Common Debugging Problems with Your Logic Analyzer (AN 1326)  
[5968-5700E](#)
- Feeling Comfortable with Logic Analyzers (AN 1337)  
[5968-8291E](#)
- The Agilent Wedge: A Hands-free Solution for Probing Fine-Pitch Ics  
[5968-7142E](#)

**MMS Products**

- Lightwave Measurements with the Agilent 71400 Lightwave Signal Analyzer (AN 371)  
[5954-9137E](#)

**Manufacturing**

- Effective Spectrum Analysis Testing for Consumer Electronics Production Lines (AN 1301)  
[5966-0367E](#)
- Reducing Process Defect Escapes with Vectorless Test  
[5965-5092E](#)
- Testing GPRS and Manufacturing (AN 1362)  
[5980-2646EN](#)
- Vectorless Test Purchaser's Guide  
[5965-0805E](#)

**Materials Measurement**

- Basics of Measuring the Dielectric Properties of Materials (AN 1217-1)  
[5091-3300E](#)
- Dielectric and Magnetic Material Characterization with the Novocontrol Concept 60 System (AN 1300-8)  
[5968-4491E](#)
- Evaluation of Oxide Reliability Using V-Ramp/J-Ramp Test (AN 4156-8)  
[5963-1248E](#)
- Insulation Resistance Measurement of the Plate Type Materials (AN 1305-2)  
[5968-3400E](#)
- Permeability Measurements Using the Agilent 4291B and Agilent 1654A (AN 1300-4)  
[5966-1844E](#)
- Permittivity Measurements of PC Board and Substrate Materials Using the Agilent 4291B and Agilent 16453A (AN 1300-3)  
[5966-1847E](#)

**Measurement and Control**

- Building Complex ATE Systems Using New Software Technologies  
[5968-5936E](#)
- Control System Measurement Fundamentals Using Dynamic Signal Analyzers and Direct Characterization of Motion Control Systems (AN 1200-2)  
[5966-4475 E](#)
- Disk Drive Servo-Track Writing with Laser Interferometers (AN 325-11)  
[5952-7984](#)
- Agilent BASIC for Windows  
[5964-6019E](#)
- Introduction to Agilent Standard Instrument Control Library  
[5963-2228E](#)
- Non-Contact Measurements with Laser Interferometers (AN 325-12)  
[5966-1989E](#)
- Simplified Motor Spin-up Analysis (AN 1200-1)  
[5966-4474 E](#)
- Submicron Positioning with the Agilent 5527A Laser Position Transducer System and Agilent 10936A Servo-Axis Board (AN 325-10)  
[5952-7942](#)

**Mechanical Products**

- Simplified Motor Spin-up Analysis (AN 1200-1)  
[5966-4474 E](#)

**Microprocessors**

- 8 Hints for Solving Common Debugging Problems with Your Logic Analyzer (AN 1326)  
[5968-5700E](#)
- Troubleshooting 8-bit MCU-Based Designs Using the Agilent 54645D Mixed Signal Oscilloscope  
[5966-1080EE](#)

**Microwave Components**

- Amplifier Measurements Using the Scalar Network Analyzer (AN 345-1)  
[5954-1599](#)
- Examine Channel Switching Characteristics of Cellular Radios (AN 1200-10)  
[5966-4483 E](#)
- Simplified Analysis of Phase-Locked Loop Capture and Tracking Range (AN 1200-7)  
[5966-4480 E](#)

**Microwave and RF**

- A Guide to Microwave Upconversion (AN 314-5)  
[5953-2342](#)
- Agilent EPM Series, Agilent 437B or Agilent 438A Compatibility  
[5968-4519E](#)
- Automated Characterization of Microwave VCOs Using the Agilent 5361A/B Pulse/CW Microwave Counter (AN 377-2)  
[5952-7988](#)
- Automatic Frequency Settling Time Measurement Speeds Time-to-Market for RF Designs  
[5964-4335E](#)
- Basics of Measuring the Dielectric Properties of Materials (AN 1217-1)  
[5091-3300E](#)
- Component Test (AN 369-3)  
[5950-2951](#)
- Digital Radio Theory and Measurements (AN 355A)  
[5091-4777E](#)
- Effective Impedance Measurement Using OPEN/SHORT/LOAD Correction (AN 346-3)  
[5091-6553E](#)
- Evaluating Microstrip with Time Domain Reflectometry (AN 1304-1)  
[5968-0007E](#)
- Examine Channel Switching Characteristics of Cellular Radios (AN 1200-10)  
[5966-4483 E](#)
- Examine GMSK Modulation in GSM and PCN Mobile Communications Systems (AN 1200-11)  
[5965-9650E](#)
- Extending Dynamic Range of Scalar Transmission Measurements Using the Agilent 8757A, 8756A, or 8755C Scalar Network Analyzers (AN 327-1)  
[5953-8882](#)
- Fundamentals of RF and microwave Power Measurements (AN 64-1A)  
[5965-6630E](#)
- High Accuracy and Fast RF Inductor Testing (AN 369-10)  
[5091-1596E](#)
- 8 Hints for Making Better Measurements Using Analog RF signal Generators (AN 1306-1)  
[5967-5661E](#)
- 8 Hints for Successful Impedance Measurement (AN 346-4)  
[5968-1947E](#)
- Lightwave Measurements with the Agilent 71400 Lightwave Signal Analyzer (AN 371)  
[5954-9137E](#)
- Network, Spectrum, and Impedance Evaluation of Electronic Circuits and Components (AN 1308-1)  
[5967-5942E](#)
- Optimizing Spectrum Analyzer Amplitude Accuracy (AN 1316)  
[5968-3659E](#)

Optimizing Spectrum Analyzer Measurement Speed (AN 1318)  
[5968-3411E](#)

Peak Deviation and Center Frequency Measurements for CT2 and DECT Radios (AN 1200-12)  
[5966-4484E](#)

Performing Bluetooth RF Measurements Today  
[5968-7746E](#)

Practical Design and Evaluation of High-Frequency Circuits (AN 317)  
[5953-6910](#)

S-Parameter Design (AN 154)  
[5952-1087](#)

Simplified Filter Tuning Using Time Domain (AN 1287-8)  
[5968-5328E](#)

Single Shot Frequency Profiling of Chirped Radars Made Easy (AN 1200-8)  
[5966-4481E](#)

Spectrum Analysis AM and FM (AN 150-1)  
[5954-9130](#)

Spectrum Analyzer Basics (AN 150)  
[5952-0292](#)

4 Steps for Making Better Power Measurements (AN 64-4A)  
[5965-8167E](#)

Testing and Troubleshooting Digital RF Communications Receiver Designs (AN 1314)  
[5968-3579E](#)

Testing and Troubleshooting Digital RF Communications Transmitter Designs (AN 1313)  
[5968-3578E](#)

Testing Digital MW Receivers with a Calibrated Source (AN 343-6)  
[5952-0800](#)

Time Domain Reflectometry Theory (AN 1304-2)  
[5966-4855E](#)

Understanding CDMA Measurements for Base Stations and Their Components (AN 1311)  
[5968-0953E](#)

Understanding GSM Transmitter Measurements for Base Transceiver Stations and Mobile Stations (AN 1312)  
[5968-2320E](#)

Using Impedance Measurement to Evaluate Electronic Components and Materials—Agilent 4284A Application Information (AN 369-1)  
[5950-2949](#)

Video Elementary Stream Analyzer—E6310A  
[5965-6491E](#)

## Mixers

Network, Spectrum, and Impedance Evaluation of IF Circuits—Agilent 4195A Network/Spectrum Analyzer (AN 357-1)  
[5950-2931](#)

## Modulation

Basic Operation & Application Guide, Agilent 8904A Operation Made Easy (AN 8904A)  
[5953-8491](#)

Digital Modulation in Connection Systems—An Introduction  
[5965-7160E](#)

Digital Radio Theory and Measurements (AN 355)  
[5091-4777E](#)

Examine GMSK Modulation in GSM and PCN Mobile Communications Systems (AN 1200-11)  
[5965-9650E](#)

Fast Characterization of Pulse-Width Encoded Data (AN 1200-5)  
[5966-4478E](#)

Measurements On Digital Modulation Components Requiring A Complex Stimulus (AN 1353)  
[5980-1337E](#)

Measuring Demodulator Image Rejection Using the Agilent 8980A Vector Analyzer (AN 1200-7)  
[5952-3703](#)

Measuring Microwave Radio Antenna Return Loss Using the Agilent 11758T Digital Radio Test System (AN 379-2)  
[5959-8749](#)

Practical Strain Gauge Measurements (AN 290-1)  
[5952-8880](#)

Pulsed Carrier Phase Noise Measurements (AN 1309)  
[5968-2081E](#)

Single Shot Frequency Profiling of Chirped Radars Made Easy (AN 1200-8)  
[5966-4481E](#)

Spectrum Analysis AM and FM (AN 150-1)  
[5954-9130](#)

Understanding the Fundamental Principles of Vector Network Analyzers (AN 1287-1)  
[5965-7707E](#)

Vector Modulation Measurements: Measurement Applications for Digital Microwave Radio (AN 343-1)  
[5954-6365](#)

## Motion Control

Direct Characterization of Motion Control Systems (AN 1200-2)  
[5966-4475E](#)

Disk Drive Servo-Track Writing with Laser Interferometers (AN 325-11)  
[5952-7984](#)

Non-Contact Measurements with Laser Interferometers (AN 325-12)  
[5966-1989E](#)

Simplified Motor Spin-up Analysis (AN 1200-1)  
[5966-4474E](#)

Submicron Positioning with the Agilent 5527A Laser Position Transducer System and Agilent 10936A Servo-Axis Board (AN 325-10)  
[5952-7942](#)

## Network Analysis, RF, Microwave and Lightwave

8 Hints for Making Better Network Analyzer Measurements (AN 1291-1)  
[5965-8166E](#)

Applying Error Correction to Network Analyzer Measurements (AN 1287-3)  
[5965-7709E](#)

Balanced Circuit Measurement with an Impedance Analyzer/LCR Meter/Network Analyzer (AN 346-2)  
[5091-4480E](#)

Basics of Measuring the Dielectric Properties of Materials (AN 1217-1)  
[5091-3300E](#)

Combining Network and Spectrum Analysis and IBASIC to Improve Device Characterization and Time Set  
[5965-7656E](#)

Dynamic Signal Analyzer Applications (AN 243-1)  
[5091-2777E](#)

Exploring the Architectures of Network Analyzers (AN 1287-2)  
[5965-7708E](#)

Fundamentals of Signal Analysis (AN 243)  
[5952-8898E](#)

Improving Network Analyzer Measurements of Frequency-Translating Devices (AN 1287-7)  
[5966-3318E](#)

Improving Throughput in Network Analyzer Applications (AN 1287-5)  
[5966-3317E](#)



In-Fixture Measurements Using Vector Network Analyzers (AN 1287-9)  
5968-5329E

Network Analyzer Measurements: Filter and Amplifier Examples (AN 1287-4)  
5965-7710E

Network, Spectrum, and Impedance Evaluation of IF Circuits: Agilent 4195A Network/Spectrum Analyzer  
5950-2931

Understanding the Fundamental Principles of Vector Network Analyzers (AN 1287-1)  
5965-7707E

Using a Network Analyzer to Characterize High-Power Components (AN 1287-6)  
5966-3319E

### Networks, Computer and Communications

1609/07A ATM Stream Processor  
5968-6561E

ABR Technology Overview and Testing Challenges  
5968-1234E

ADSL Line Qualification and Troubleshooting with the Service Advisor 2 MHz TIMS Module  
5968-3731E

Advanced Testing Techniques for ATM Service Level Agreements  
5968-6560E

Agilent Internet Advisor Troubleshooting Frame Relay (AN 1323)  
5968-5310E

Agilent Internet Advisor Troubleshooting VoIP Signaling (AN 1320)  
5968-4450E

Agilent NetMatrix RMON2 Delivered Through Measuring Extinction Ratio of Optical Transmitters (AN 1550-8)  
5966-4316E

Agilent Technologies ParBERT 81250, Mux/Demux Application  
5968-9695E

ATM Forum Conformance Testing to Ensure Your P-NNI Implementation is Ready to Plug-and-Play  
5966-1004E

10/100 Base-T Testing  
5968-5053E

Basic ATM Troubleshooting with the Agilent Internet Advisor (AN 1327)  
5968-5924E

Commissioning and Testing Echo Canceller Equipment with The T1/E1 Test Advisor  
5968-3294E

Connecting Agilent Technologies Test Sets for In-Service Testing of PDH/SDH Networks  
5965-5898E

Designing Packet over SONET/SDH (POS) Hardware  
5968-1614E

Dual Simultaneous Measurements (AN 1346)  
5980-0547E

Evaluating Tributary Jitter from the SDH Network (AN 1258)  
5962-9551E

Ethernet/Fast Ethernet Problems and Solutions (AN 1336)  
5968-8428E

Functional Testing of ATM Signaling Protocols  
5965-9331E

Implementing ATM Signaling: Avoiding the Interoperability Pitfalls  
5963-7514E

Internet Protocol Quality of Service  
5968-9722E

Internet Routing Protocol Testing  
5968-9391E

NNI Signaling Test Software Helps Ensure Seamless ATM Networks  
5965-6307E

Operating LANs in an ATM Environment  
5963-7513E

Performing Bluetooth RF Measurements Today  
5968-7746E

POS Router Latency Testing  
5968-9724E

Signaling Performance Case Studies using the Agilent Multiport UNI Signaling Performance Test Solution  
5968-1235E

Testing ATM at 622 Mb/s and Above  
5965-9333E

Testing ATM Interoperability  
5965-9334E

Testing ATM Signaling Performance  
5965-9330E

Testing Operation and Maintenance (OAM) Implementations for ATM  
5965-9332E

Testing QoS, OAM, Policing, and Performance at 622 Mb/s and 2.4 Gb/s  
5968-1237E

Testing Techniques for Next Generation IP Networks  
5968-1236E

Testing Standard and CRC-4 2.048 Mb/s Systems (AN 1321)  
5968-4518E

Testing to Ensure Your P-NNI Implementation is Ready to Plug-and-Play  
5966-1004E

Troubleshooting Frame Relay (AN 1323)  
5968-5310E

Troubleshooting VoIP Signaling  
5968-4450E

The Quest for Quality: The ATM Impairment Testing Handbook  
5965-4992E

Transport Stream Packet Timestamping—a Fundamental Necessity for MPEG Testing  
5968-2015E

WAN Interworking with ATM  
5963-7512E

Verifying and Evaluating Gigabit Switch/Routers Performance with Internet-Scale Simulation  
5968-1233E

### Noise

10 Hints for Making Successful Noise Figure Measurements (AN 1341)  
5980-0288E

Complete Analysis of Erbium-Doped Fiber Amplifiers  
5965-0976E

Fast Characterization of Pulse-Width Encoded Data (AN 1200-5)  
5966-4478E

Low Phase Noise Applications of the Agilent 8662A and 8663A Synthesized Signal Generators  
5953-8435

Noise Figure Measurement Accuracy (AN 57-2)  
5952-3706

Pulsed Carrier Phase Noise Measurements (AN 1309)  
5968-2081E

Pulsed Carrier Phase Noise, Measurements Using the Agilent 3048A Phase Noise, Measurement System (AN 386)  
5951-6743

Quick Identification of Periodic Jitter Sources (AN 1200-4)  
5966-4477E

Signal Generator (AN 388)  
5952-2019

Spectrum Analyzer Measurements and Noise (AN 1303)  
5966-4008E

### Oscillators

Automated Characterization of Microwave VCOs Using the Agilent 5361A/B Pulse/CW Microwave Counter (AN 377-2)  
5952-7988

Examine Channel Switching Characteristics of Cellular Radios (AN 1200-10)  
5966-4483E

Fundamentals of Microwave Frequency Counters (AN 200-1)  
5965-7661E

Fundamentals of Quartz Oscillators (AN 200-2)  
5965-7662E

Microprobing with the Agilent 54750 Oscilloscope (AN 1304-3)  
5968-0773E

Network, Spectrum, and Impedance Evaluation of IF Circuits: Agilent 4195A Network/Spectrum Analyzer  
5950-2931

VCO Step Response Analysis Made Easy (AN 1200-3)  
5966-4476E

Many of these documents are orderable and downloadable from Agilent's web site:

[www.agilent.com/find/apps](http://www.agilent.com/find/apps)

**Oscilloscopes**

- Agilent Technologies 54622D 12C Debugging (AN 1351)  
[5980-0796EUS](#)
- Agilent Technologies 54622S MSO and CEBus PL Communications Testing (AN 1352)  
[5980-0794EUS](#)
- 8 More Hints for making Better Scope Measurements  
[5968-8756E](#)
- Characterizing High-Speed Optical Transmitters Compliance Testing with the Agilent 86100A Infiniium DCS (AN 1340-1)  
[5968-9249E](#)
- PCI Timing Check Using the Agilent E2920 PCI Series Exerciser/Analyzer  
[5968-5816E](#)
- The Agilent Wedge: A Hands-free Solution for Probing Fine-Pitch Ics  
[5968-7142E](#)

**Phase Linearity**

- Fundamentals of Microwave Frequency Counters (AN 200-1)  
[5965-7661E](#)

**Phase Stability**

- Histograms Simplify Analysis of Random Jitter (AN 1200-9)  
[5966-4482E](#)
- Low Phase Noise Applications of the Agilent 8662A and 8663A Synthesized Signal Generators  
[5953-8435](#)
- Pulsed Carrier Phase Noise Measurements (AN 1309)  
[5968-2081E](#)

**Physical/Mechanical Design and Test**

- Contact Resistance and Insulation Resistance Measurements of Electro-mechanical Components (AN 1305-1)  
[5968-0325](#)
- Fundamentals of Signal Analysis (AN 243)  
[5952-8898E](#)
- Simplified Motor Spin-up Analysis (AN 1200-1)  
[5966-4474E](#)
- The Fundamentals of Modal Testing (AN 243-3)  
[5954-7957E](#)

**Power Measurement**

- Choosing the Right Average Power Sensor for Wireless Test  
[5968-7150E](#)
- Compliance Testing to the IEC 1000-3-2 and (EN 61000-3-2) and IEC 1000-3-3 (EN 61000-3-3) Standards (AN 1273)  
[5964-1917E](#)

- Debugging Modern Power Electronics: Seeing the Whole Picture (AN 1350)  
[5980-0797EUS](#)
- Fundamentals of RF and Microwave Power Measurements (AN 64-1A)  
[5965-6630E](#)
- Agilent EPM Series, Agilent 437B or Agilent 438A Compatibility  
[5968-4519E](#)
- Agilent 6800 Series AC Power Source/Analyzer  
[5963-7044E](#)
- 4 Steps for Making Better Power Measurements (AN 64-4A)  
[5965-8167E](#)
- Testing CDMA Base Station Amplifiers (AN 1307)  
[5967-5486E](#)
- Using a Network Analyzer to Characterize High-Power Components (AN 1287-6)  
[5966-3319E](#)

**Power Supplies**

- Biasing Three-Terminal Devices for Test (AN 376-1)  
[5952-4193](#)
- Compliance Testing to the IEC 1000-3-2 and (EN 61000-3-2) and IEC 1000-3-3 (EN 61000-3-3) Standards (AN 1273)  
[5964-1917E](#)
- Considerations when Selecting a System Power Supply for Mobile Communications Device Testing (AN 1310)  
[5968-2424E](#)
- DC Power Supply Handbook (AN 90B)  
[5952-4020](#)
- Pulsed Characteristics of Power Semiconductors Using Electronic Loads (AN 1246)  
[5091-7636E](#)
- Sequential Shunt Regulation (AN 1293)  
[5965-7329E](#)

**Power Transistors**

- Measurement of Power Devices Using External DC Power Supply (AN 4156-5)  
[5963-2365E](#)
- Pulsed Characteristics of Power Semiconductors Using Electronic Loads (AN 1246)  
[5091-7636E](#)

**Production Test**

- Agilent BASIC for Windows  
[5964-6019E](#)
- Battery Testing (AN 372-2)  
[5952-4191](#)
- Characterizing Communications ICs With The Agilent 83000 Model F660  
[5962-9273EUS](#)
- Connect Check Backgrounder  
[5965-5092E](#)

- Peak Deviation and Center Frequency Measurements for CT2 and DECT Radios (AN 1200-12)  
[5966-4484E](#)
- Practical Strain Gauge Measurements (AN 290-1)  
[5952-8880](#)
- System Test with Localized RT-DSP  
[5966-3342E](#)
- Vectorless Test Purchaser's Guide  
[5965-0805E](#)

**Protocol Analysis**

- SS7 Protocol Testing With PT Series Protocol Testers  
[5962-9408EUS](#)
- Transport Stream Packet Timestamping—a Fundamental Necessity for MPEG Testing  
[5968-2015E](#)

**Pulse Measurements**

- Automatic Frequency Profiling of Chirped Radar Pulses Using the Agilent 5361A/B Pulse/CW Microwave Counter (AN 377-1)  
[5952-7987](#)
- Frequency Profiling without a Pulse Generator (AN 377-3)  
[5952-7991](#)
- Fundamentals of Microwave Frequency Counters (AN 200-1)  
[5965-7661E](#)
- Single Shot Frequency Profiling of Chirped Radars Made Easy (AN 1200-8)  
[5966-4481 E](#)

**Radar**

- Automatic Frequency Profiling of Chirped Radar Pulses Using the Agilent 5361A/B Pulse/CW Microwave Counter  
[5952-7987](#)
- Low Phase Noise Applications of the Agilent 8662A and 8663A Synthesized Signal Generators (AN 283-3)  
[5953-8435](#)
- Pulsed Carrier Phase Noise Measurements Using the Agilent 3048A Phase Noise Measurement System (AN 386)  
[5951-6743](#)
- Simplified Analysis of Phase-Locked Loop Capture and Tracking Range (AN 1200-7)  
[5966-4480 E](#)
- Single Shot Frequency Profiling of Chirped Radars Made Easy (AN 1200-8)  
[5966-4481 E](#)
- VCO Step Response Analysis Made Easy (AN 1200-3)  
[5966-4476 E](#)
- Vector Modulation Measurements/Coherent Pulsed Tests of Radar and EW Systems (AN 043-3)  
[5954-6366](#)

## Receivers

- 10 Hints for Making Successful Noise Figure Measurements (AN 1341)  
[5980-0288E](#)
- Generating Custom, Real-World Waveforms (AN 1360)  
[5980-2518EN](#)
- Measuring EDGE Signals—New and Modified Techniques and Measurement Requirements (AN 1361)  
[5980-2508EN](#)
- Measuring Microwave Radio Antenna Return Loss Using the Agilent 11758T Digital Radio Test System (AN 379-2)  
[5959-8749](#)
- Practical Noise Figure Measurement and Analysis for Low-Noise Amplifier Designs (AN 1354)  
[5980-1916E](#)
- Signal Generator (AN 388)  
[5952-2019](#)
- Testing Digital MW Receivers with a Calibrated Source (AN 343-6)  
[5952-0800](#)
- Vector Modulation Measurements: Measurement Applications for Digital Microwave Radio (AN 343-1)  
[5954-6365](#)

## Reflectometers

- Beginner's Guide to Using the Agilent 8147 Optical Time Domain Reflectometer  
[5964-6672E](#)

## Rotating Machinery

- Direct Characterization of Motion Control Systems (AN 1200-2)  
[5966-4475E](#)
- Simplified Motor Spin-up Analysis (AN 1200-1)  
[5966-4474E](#)

## S-Parameters

- Exploring the Architectures of Network Analyzers (AN 1287-2)  
[5965-7708E](#)
- S-Parameter Techniques for Faster, More Accurate Network Design (AN 95-1)  
[5952-1130](#)

## Satellite Communications

- Simple Analysis of Frequency Modulation (AN 1200-6)  
[5966-4479 E](#)
- VCO Step Response Analysis Made Easy (AN 1200-3)  
[5966-4476 E](#)

## Secure Data Transmission

- Riding the Internet Wave: Ensuring Safe, Solid Internet Services for the Enterprise (AN 1295)  
[5965-9371E](#)

## Semiconductors

- Accurate and Effective Flash Memory Cell Evaluation Using the Agilent 4072A  
[5968-6719E](#)
- Accurate and Efficient C-V Measurements  
[5965-5658E](#)
- Accurate and Efficient Frequency Evaluation of a Ring Oscillator (AN 4070-3)  
[5968-4310E](#)
- Accurate Capacitance Characterization at the Wafer Level (AN 4070-2)  
[5968-2499E](#)
- Automated Extraction of Semiconductor Parameters using the Agilent 4155A/4156A (AN 4156-2)  
[5963-1249E](#)
- Characterizing Communications ICs with The Agilent 83000 Model F660  
[5962-9273EUS](#)
- DC Parametric Analysis of Semiconductor Devices (AN G002)  
[5950-2928](#)
- Evaluation of Electromigration Using the SWEAT Procedure (AN 4156-7)  
[5963-1110E](#)
- Evaluation of Flash Memory Cells (AN 4156-4)  
[5965-5657E](#)
- Evaluation of Hot Carrier Induced Degradation of MOSFET Devices (AN 4156-3)  
[5963-1111E](#)
- Evaluation of Hot Carrier Induced Degradation of MOSFET Devices Application Flyer  
[5964-9113E](#)
- Evaluation of Oxide Reliability using V-Ramp/J-Ramp Test (AN 4156-8)  
[5963-1248E](#)
- Evaluation of the Surface State Using Charge Pumping Methods (AN 4156-9)  
[5964-2195E](#)
- Hierarchical Modeling for Circuit Characterization (AN 1201-2)  
[5091-1668E](#)
- Agilent 4155A/4156A Semiconductor Parameter Analyzer—Edition 1 Programming Guide for Agilent 4145A/B Users  
[5963-3201E](#)
- Low Current Measurement with Agilent E65250A Switch Mainframe  
[5964-9112E](#)
- Maximizing the Incoming Inspection Efficiency of Semiconductor Devices (AN 4156-6)  
[5963-2364E](#)
- Measurement of Power Devices Using External DC Power Supply (AN 4156-5)  
[5963-2365E](#)
- Memory Test Software Provides Cost-Effective Solutions to Testing Advanced SRAMs  
[5963-5078E](#)
- Multifrequency C-V Measurements and Doping Profile Analysis of Semiconductors Using the Agilent 4194A (AN 339-5)  
[5950-2919](#)
- Multifrequency C-V Measurements of Semiconductors—Agilent 4284A Application Information (AN 369-5)  
[5950-2953](#)
- Optimizing the Incoming Inspection of Semiconductor Devices (AN 4156-6)  
[5963-2364E](#)
- Precision Evaluation of Flash Memory Cells (AN 4062-2)  
[5091-6806E](#)
- Role of DC Parametric Test in High Speed Digital (AN 339-20)  
[5952-7936](#)
- Semiconductor Measurements with the Agilent 4140B Picoammeter/DC Voltage Source (AN 238)  
[5952-8840](#)
- Simplification of DC Characterization and Analysis of Semiconductor Devices (AN 383-1)  
[5950-2396](#)
- Techniques and Applications for High Throughput and Stable Characterization (AN 356-1)  
[5950-2954](#)
- The Agilent 4062UX Provides High Performance Data Management and Powerful Networking Capabilities (Transfer Data to BD/DA System) (AN 382-1)  
[5950-2393](#)
- Ultra Low Current DC Characterization at the Wafer Level (AN 4070-1)  
[5965-7352E](#)
- Ultra Low Current DC Characterization of MOSFETs at the Wafer Level (AN 4156-1)  
[5963-2014E](#)
- Ultra Low Current Semiconductor DC Parameter Measurement System Using Agilent 4140B (AN 238-1)  
[5952-8873](#)

## Signal Generators

- 8 Hints for Making Better Measurements Using Analog RF signal Generators (AN 1306-1)  
[5967-5661E](#)
- Low Phase Noise Applications of the Agilent 8662A and 8663A Synthesized Signal Generators  
[5953-8435](#)
- VOR/ILS Testing with Agilent 8644A (AN 8644-2)  
[5951-6740](#)

Many of these documents are orderable and downloadable from Agilent's web site:

[www.agilent.com/find/apps](http://www.agilent.com/find/apps)

**Signal Sources**

- Characterizing Components with a Microwave Tracking Source (AN 1212)  
[5091-2172E](#)
- External Frequency Doubling of the Agilent 8662A Synthesized Signal Generator (AN 283-2)  
[5952-8217](#)
- Pulsed Carrier Phase Noise Measurements Using the Agilent 3048A Phase Noise Measurement System (AN 386)  
[5951-6743](#)

**Smith Chart**

- S-Parameter Techniques for Faster, More Accurate Network Design (AN 95-1)  
[5952-1130](#)

**Spectrum Analysis**

- Accurate and Efficient Frequency Evaluation of a Ring Oscillator (AN 4070-3)  
[5968-4310E](#)
- Effective Spectrum Analysis Testing for Consumer Electronics Production Lines (AN 1301)  
[5966-0367E](#)
- Eight Hints for Making Better Spectrum Analyzer Measurements  
[5965-7009E](#)
- Fundamentals of Signal Analysis (AN 243)  
[5952-8898E](#)
- Network, Spectrum, and Impedance Evaluation of IF Circuits—Agilent 4195A Network/Spectrum Analyzer (AN 357-1)  
[5950-2931](#)
- Non-Contact Measurements with Laser Interferometers (AN 325-12)  
[5966-1989E](#)
- Optical Spectrum Analysis Basics  
[5963-7145E](#)
- Optimizing Spectrum Analyzer Amplitude Accuracy (AN 1316)  
[5968-3659E](#)
- Optimizing Spectrum Analyzer Dynamic Range  
[5968-4545E](#)
- Optimizing Spectrum Analyzer Measurement Speed (AN 1318)  
[5968-3411E](#)
- Precision Time-Domain Measurement Using the Agilent E1430A  
[5962-0015E](#)
- Spectrum Analysis AM and FM (AN 150-1)  
[5954-9130](#)
- Spectrum Analyzer Basics (AN 150)  
[5952-0292](#)
- Spectrum Analyzer Measurements and Noise (AN 1303)  
[5966-4008E](#)

**Standards**

- Cookbook for EMC Precompliance Measurements (AN 1290-1)  
[5964-2151E](#)

**Swept-Frequency Measurements**

- Characterizing Components with a Microwave Tracking Source (AN 1212)  
[5091-2172E](#)
- Dynamic Signal Analyzer Applications (AN 243-1)  
[5091-2777E](#)
- Low Phase Noise Applications of the Agilent 8662A and 8663A Synthesized Signal Generators (AN 283-3)  
[5953-8435](#)
- Pulsed Carrier Phase Noise, Measurements Using the Agilent 3048A Phase Noise, Measurement System (AN 386)  
[5951-6743](#)
- Single Shot Frequency Profiling of Chirped Radars Made Easy (AN 1200-8)  
[5966-4481E](#)

**Switching**

- Low Current Measurement with Agilent E5250A Switch Mainframe (AN E5250A-1)  
[5964-9112E](#)

**Synthesizers/Signal Generators**

- External Frequency Doubling of the Agilent 8662A Synthesized Signal Generator (AN 283-2)  
[5952-8217](#)
- Optimizing VCO/PLL Evaluations and PLL Synthesizer Designs  
[5968-6772E](#)
- Pulsed Carrier Phase Noise, Measurements Using the Agilent 3048A Phase Noise, Measurement System (AN 386)  
[5951-6743](#)
- Signal Generator (AN 388)  
[5952-2019](#)

**Tape Recording**

- Fast Characterization of Pulse-Width Encoded Data (AN 1200-5)  
[5966-4478E](#)
- Histograms Simplify Analysis of Random Jitter (AN 1200-9)  
[5966-4482E](#)

**Telecommunications**

- ABR Technology Overview and Testing Challenges  
[5968-1234E](#)
- ADSL Line Qualification and Troubleshooting with the Service Advisor 2 MHz TIMS Module  
[5968-3731E](#)
- ADSL Line Qualification and Troubleshooting with N1626A  
[5968-3923E](#)
- Amplifier Measurements Using the Scalar Network Analyzer (AN 345-1)  
[5954-1599](#)
- ATM Forum Conformance Testing to Ensure Your P-NNI Implementation is Ready to Plug-and-Play  
[5966-1004E](#)
- Basic ATM Troubleshooting with the Agilent Internet Advisor (AN 1327)  
[5968-5924E](#)
- Commissioning and Testing Echo Canceller Equipment with the T1/E1 Test Advisor  
[5968-3294E](#)
- Evaluating Tributary Jitter from the SDH Network (AN 1258)  
[5962-9551E](#)
- Examine GMSK Modulation in GSM and PCN Mobile Communications Systems (AN 1200-11)  
[5965-9650E](#)
- Functional Testing of ATM Signaling Protocols  
[5965-9331E](#)
- Getting the Most Out of Your T1 and DDS Services  
[5091-6174E](#)
- High Productivity Measurements in Digital Transmission (AN 387)  
[5959-7898](#)
- High-Speed Lightwave Component Analysis (AN 1550-6)  
[5091-6478E](#)
- Lightwave Measurements with the Agilent 71400 Lightwave Signal Analyzer (AN 371)  
[5954-9137E](#)
- Maximizing Revenue with In-Service Testing: Introduction (AN 1237-1)  
[5091-6009E](#)
- Maximizing Revenue with In-Service Testing—Centralized Testing/Monitoring Systems (AN 1237-2)  
[5091-6349E](#)
- Operating LANs in an ATM Environment  
[5963-7513E](#)
- Signaling Performance Case Studies using the Agilent Multiport UNI Signaling Performance Test Solution  
[5968-1235E](#)
- Simple Analysis of Frequency Modulation (AN 1200-6)  
[5966-4479E](#)



Simplified Analysis of Phase-Locked Loop Capture and Tracking Range (AN 1200-7)  
5966-4480E

SS7 Protocol Testing With PT Series Protocol Testers  
5962-9408EUS

Telegra D and m Fax System (AN 1359)  
5980-2196E

Testing n x 64 kb/s Services (AN 1211-2)  
5091-2069E

Testing Sub-rate Data Services (AN 1211-3)  
5091-2072E

Testing Standard and CRC-4 2.048 Mb/s Systems (AN 1321)  
5968-4518E

The Personal Handy Phone System in Japan's Wireless Communication Market  
5964-6753E

Troubleshooting VoIP Signaling  
5968-4450E

Vector Modulation Measurements—Measurement Applications for Digital Microwave Radio (AN 343-1)  
5954-6365

WAN Interworking with ATM  
5963-7512E

## Temperature Measurement

Practical Temperature Measurements (AN 290)  
5965-7822E

## Test Systems

A Quality Test Demands a Quality Fixture  
5965-6624E

Agilent E8491B IEEE-1394-to-VXI: Increasing Test System Throughput  
5968-7237E

Agilent Technologies E8758A Compact VXI Foundation System and I/O Modules  
5968-9861EUS

Agilent TS-5400 Series II Remote Keyless Entry Application  
5968-6080E

Agilent TS-5400 Series II Supplemental Restraint Systems  
5968-6356E

Agilent VXI Test System Signal Switching  
5968-7234E

Automated Characterization of Microwave VCOs Using the Agilent 5361A/B Pulse/CW Microwave Counter (AN 377-2)  
5952-7988

Automated Extraction of Semiconductor Parameters Using the Agilent 4155A/4156A (AN 4156-2)  
5963-1249E

Battery Testing (AN 372-2)  
5952-4191

Building Complex ATE Systems Using New Software Technologies  
5968-5936E

Evaluation of Electromigration Using the SWEAT Procedure (AN 4156-7)  
5963-1110E

Evaluation of Hot Carrier Induced Degradation of MOSFET Devices (AN 4156-3)  
5963-1111E

Evaluation of Oxide Reliability Using V-Ramp/J-Ramp Tests (AN 4156-8)  
5963-1248E

Agilent BASIC for Windows  
5964-6019E

Introduction to Agilent Standard Instrument Control Library  
5963-2228E

Low Phase Noise Applications of the Agilent 8662A and 8663A Synthesized Signal Generators (AN 283-3)  
5953-8435

Measurement of Power Devices Using External DC Power Supply (AN 4156-5)  
5963-2365E

Optimizing the Incoming Inspection of Semiconductor Devices (AN 4156-6)  
5963-2364E

Peak Deviation and Center Frequency Measurements for CT2 and DECT Radios (AN 1200-12)  
5966-4484E

Pulsed Carrier Phase Noise Measurements Using the Agilent 3048A Phase Noise Measurement System (AN 386)  
5951-6743

Pulsed Characteristics of Power Semiconductors Using Electronic Loads (AN 1246)  
5091-7636E

Reducing Process Defect Escapes with Vectorless Test  
5965-5092E

SEMI S2 Standard Modifications for Agilent 3070 and Related Equipment  
5980-0941E

TS5400 Series II Antilock Brakes & Traction Control Application  
5968-6079E

Ultra Low Current DC Characterization of MOSFETs at the Wafer Level (AN 4156-1)  
5963-2014E

## Time/Timekeeping

The Science of Timekeeping (AN 1289)  
5965-7984E

Transport Stream Packet Timestamping—a Fundamental Necessity for MPEG Testing  
5968-2015E

## Time-Interval

Fundamentals of Time Interval Measurements (AN 200-3)  
5965-7663

Histograms Simplify Analysis of Random Jitter (AN 1200-9)  
5966-4482E

Quick Identification of Periodic Jitter Sources (AN 1200-4)  
5966-4477E

## Timing Analysis

Fast Characterization of Pulse-Width Encoded Data (AN 1200-5)  
5966-4478E

Histograms Simplify Analysis of Random Jitter (AN 1200-9)  
5966-4482E

100 PCI Timing Check Using the Agilent E2920 PCI Series Exerciser/Analyzer  
5968-5816E

Quick Identification of Periodic Jitter Sources (AN 1200-4)  
5966-4477E

## Transforms

Fundamentals of Signal Analysis (AN 243)  
5952-8898E

## Transistors

Automated Extraction of Semiconductor Parameters Using the Agilent 4155A/4156A (AN 4156-2)  
5963-1249E

Biasing Three-Terminal Devices for Test (AN 376-1)  
5952-4193

Evaluation of Hot Carrier Induced Degradation of MOSFET Devices (AN 4156-3)  
5963-1111E

Evaluation of Oxide Reliability Using V-Ramp/J-Ramp Tests (AN 4156-8)  
5963-1248E

Measurement of Power Devices Using External DC Power Supply (AN 4156-5)  
5963-2365E

Optimizing the Incoming Inspection of Semiconductor Devices (AN 4156-6)  
5963-2364E

Pulsed Characteristics of Power Semiconductors Using Electronic Loads (AN 1246)  
5091-7636E

S-Parameter Techniques for Faster, More Accurate Network Design (AN 95-1)  
5952-1130

Ultra Low Current DC Characterization of MOSFETs at the Wafer Level (AN 4156-1)  
5963-2014E

Many of these documents are orderable and downloadable from Agilent's web site:

[www.agilent.com/find/apps](http://www.agilent.com/find/apps)

**Transmission Lines**

- S-Parameter Design (AN 154)  
[5952-1087](#)
- Testing n x 64 kb/s Services (AN 1211-2)  
[5091-2069E](#)
- Testing Sub-rate Data Services (AN 1211-3)  
[5091-2072E](#)

**Troubleshooting and Debugging Analog, Digital and Logic**

- 8 Hints for Common Debugging Problems with Your Logic Analyzer  
[5968-5700E](#)
- 8 Hints for Solving Common Debugging Problems with Your Logic Analyzer (AN 1326)  
[5968-5700E](#)
- 8 More Hints for making Better Scope Measurements  
[5968-8756E](#)
- ADSL Line Qualification and Troubleshooting with the Service Advisor 2 MHz TIMS Module  
[5968-3731E](#)
- Agilent Technologies 54622D 12C Debugging (AN 1351)  
[5980-0796EUS](#)
- Agilent Technologies 54622S MSO and CEBus PL Communications Testing (AN 1352)  
[5980-0794EUS](#)
- An Introduction to Error Location Analysis (AN 1550-2)  
[5980-0648E](#)
- Basic Operation & Application Guide Agilent 8904A Operation Made Easy (AN 8904A)  
[5953-8491](#)
- Battery Charging/Discharging (AN 250-2)  
[5952-4033](#)
- Battery Testing (AN 372-2)  
[5952-4191](#)
- Biasing Three-Terminal Devices for Test (AN 376-1)  
[5952-4193](#)
- Component Test (AN 369-3)  
[5950-2951](#)
- DC Parametric Analysis of Semiconductor Devices (AN G002)  
[5950-2928](#)
- DC Power Supply Handbook (AN 90B)  
[5952-4020](#)
- Debugging Modern Power Electronics: Seeing the Whole Picture (AN 1350)  
[5980-0797EUS](#)

- Feeling Comfortable with Logic Analyzers (AN 1337)  
[5968-8291E](#)
- Floating Measurements and Guarding (AN 123)  
[5952-2153](#)
- High Accuracy and Fast RF Inductor Testing (AN 369-10)  
[5091-1596E](#)
- Maximizing Revenue with In-Service Testing: Introduction (AN 1237-1)  
[5091-6009E](#)
- Multifrequency C-V Measurements of Semiconductors: Agilent 4284A Application Information (AN 369-5)  
[5950-2953](#)
- PCI Timing Check Using the Agilent E2920 PCI Series Exerciser/Analyzer  
[5968-5816E](#)
- Pulsed Characteristics of Power Semiconductors Using Electronic Loads (AN 1246)  
[5091-7636E](#)
- Semiconductor Measurements with the Agilent 4140B Picoammeter/DC Voltage Source (AN 238)  
[5952-8840](#)
- Simplification of DC Characterization and Analysis of Semiconductor Devices (AN 383-1)  
[5950-2396](#)
- Techniques and Applications for High Throughput and Stable Characterization (AN 356-1)  
[5950-2954](#)
- Ultra Low Current Semiconductor DC Parameter Measurement System Using Agilent 4140B (AN 238-1)  
[5952-8873](#)
- Wide-Range DC Current Biased Inductance Measurement (AN 369-8)  
[5950-2367](#)

**Troubleshooting and Debugging RF, MW, LW and Communications**

- 1609/07A ATM Stream Processor  
[5968-6561E](#)
- Advanced Testing Techniques for ATM Service Level Agreements  
[5968-6560E](#)
- ADSL Line Qualification and Troubleshooting with N1626A  
[5968-3923E](#)
- Agilent Internet Advisor Troubleshooting Frame Relay (AN 1323)  
[5968-5310E](#)
- A Guide to Microwave Upconversion (AN 314-5)  
[5953-2342](#)

- Amplifier Measurements Using the Scalar Network Analyzer (AN 345-1)  
[5954-1599](#)
- Automated Characterization of Microwave VCOs Using the Agilent 5361A/B Pulse/CW Microwave Counter (AN 377-2)  
[5952-7988](#)
- Automatic Frequency Profiling of Chirped Radar Pulses Using the Agilent 5361A/B Pulse/CW Microwave Counter  
[5952-7987](#)
- Balanced Circuit Measurement with an Impedance Analyzer/LCR Meter/Network Analyzer (AN 346-2)  
[5091-4480E](#)
- Basic ATM Troubleshooting with the Agilent Internet Advisor (AN 1327)  
[5968-5924E](#)
- Characterizing Components with a Microwave Tracking Source (AN 1212)  
[5091-2172E](#)
- Connecting Agilent Test Sets for In-Service Testing of PDH/SDH Networks  
[5965-5898E](#)
- Designing Packet over SONET/SHD (POS) Hardware  
[968-1614E](#)
- Dual Simultaneous Measurements (AN 1346)  
[5980-0547E](#)
- Dynamic Signal Analyzer Applications (AN 243-1)  
[5091-2777E](#)
- Ethernet/Fast Ethernet Problems and Solutions (AN 1336)  
[5968-8428E](#)
- Examine Channel Switching Characteristics of Cellular Radios (AN 1200-10)  
[5966-4483E](#)
- Examine GMSK Modulation in GSM and PCN Mobile Communications Systems (AN 1200-11)  
[5965-9650E](#)
- Extending Dynamic Range of Scalar Transmission Measurements Using the Agilent 8757A, 8756A, or 8755C Scalar Network Analyzers (AN 327-1)  
[5953-8882](#)
- External Frequency Doubling of the Agilent 8662A Synthesized Signal Generator (AN 283-2)  
[5952-8217](#)
- Frequency Profiling without a Pulse Generator (AN 377-3)  
[5952-7991](#)
- Functional Testing of ATM Signaling Protocols  
[5965-9331E](#)

- Fundamentals of Microwave Frequency Counters (AN 200-1)  
[5965-7661E](#)
- High Productivity Measurements in Digital Transmission (AN 387)  
[5959-7898](#)
- High-Speed Lightwave Component Analysis (AN 1550-6)  
[5091-6478E](#)
- Impedance Measurement for Incoming Inspection—Agilent 4284A Application Information (AN 369-4)  
[5950-2952](#)
- Impedance Testing Using a Scanner (AN 369-6)  
[5950-2975](#)
- Implementing ATM Signaling: Avoiding the Interoperability Pitfalls  
[5963-7514E](#)
- Internet Protocol Quality of Service  
[5968-9722E](#)
- Internet Routing Protocol Testing  
[5968-9391E](#)
- Introduction to BER Testing of WDM Systems (AN 1299)  
[5966-0911E](#)
- Lightwave Measurements with the Agilent 71400 Lightwave Signal Analyzer (AN 371)  
[5954-9137E](#)
- Measuring Demodulator Image Rejection Using the Agilent 8980A Vector Analyzer (AN 343-4)  
[5952-3703](#)
- Measuring Microwave Radio Antenna Return Loss Using the Agilent 11758T Digital Radio Test System (AN 379-2)  
[5959-8749](#)
- Measuring the Characteristic Impedance of Balanced Cables (AN 339-4)  
[5950-2918](#)
- Multi Protocol Label Switching  
[5980-1225E](#)
- Networking Capabilities (Transfer Data to BD/DA System) (AN 382-1)  
[5950-2393](#)
- Network, Spectrum, and Impedance Evaluation of IF Circuits—Agilent 4195A Network/Spectrum Analyzer (AN 357-1)  
[5950-2931](#)
- NNI Signaling Test Software Helps Ensure Seamless ATM Networks  
[5965-6307E](#)
- Noise Figure Measurement Accuracy (AN 57-2)  
[5952-3706](#)
- Optimizing Your CDMA Wireless Network Today and Tomorrow Using Drive-Test Solutions (AN 1345)  
[5968-9916E](#)
- Optimizing your GSM Network Today and Tomorrow (AN 1348-1)  
[5980-0218E](#)
- Optimizing your TDMA Network Today and Tomorrow Using Drive-testing to Identify (AN 1349-1)  
[5980-0219E](#)
- Practical Design and Evaluation of High-Frequency Circuits (AN 317)  
[5953-6910](#)
- Pulsed Carrier Phase Noise, Measurements Using the Agilent 3048A Phase Noise, Measurement System (AN 386)  
[5951-6743](#)
- S-Parameter Techniques for Faster, More Accurate Network Design (AN 95-1)  
[5952-1130](#)
- Signal Generator (AN 388)  
[5952-2019](#)
- Signaling Performance Case Studies using the Multiport UNI Signaling Performance Test Solution  
[5968-1235E](#)
- Simple Analysis of Frequency Modulation (AN 1200-6)  
[5966-4479E](#)
- Single Shot Frequency Profiling of Chirped Radars Made Easy (AN 1200-8)  
[5966-4481E](#)
- Spectrum Analysis AM and FM (AN 150-1)  
[5954-9130](#)
- Spectrum Analyzer Basics (AN 150)  
[5952-0292](#)
- Telega D and m Fax System (AN 1359)  
[5980-2196E](#)
- Testing ATM at 622 Mb/s and Above  
[5965-9333E](#)
- Testing ATM Signaling Performance  
[5965-9330E](#)
- Testing Digital MW Receivers with a Calibrated Source (AN 343-6)  
[5952-0800](#)
- Testing for GFR QoS Eligibility and Frame-based Statistics  
[5980-0565E](#)
- Testing n x 64 kb/s Services (AN 1211-2)  
[5091-2069E](#)
- Testing QoS, OAM, Policing, and Performance at 622 Mb/s and 2.4 Gb/s  
[5968-1237E](#)
- Testing Standard and CRC-4 2.048 Mb/s Systems (AN 1321)  
[5968-4518E](#)
- Testing Sub-rate Data Services (AN 1211-3)  
[5091-2072E](#)
- Testing Techniques for Next Generation IP Networks  
[5968-1236E](#)
- Testing to Ensure Your P-NNI Implementation is Ready to Plug-and-Play  
[5966-1004E](#)
- The Agilent 4062UX Provides High Performance Data Management and Powerful Troubleshooting Frame Relay (AN 1323)  
[5968-5310E](#)
- Troubleshooting VoIP Signaling  
[5968-4450E](#)
- True Router Performance Testing  
[5980-1421E](#)
- Understanding IP Analysis  
[5980-1708E](#)
- Vector Modulation Measurements/Coherent Pulsed Tests of Radar and EW Systems (AN 043-3)  
[5954-6366](#)
- Vector Modulation Measurements—Measurement Applications for Digital Microwave Radio (AN 343-1)  
[5954-6365](#)
- What is Route Convergence?  
[5980-1224E](#)
- What is Routing Instability?  
[5980-1226E](#)

### Troubleshooting and Debugging Other

- Basics of Measuring the Dielectric Properties of Materials (AN 1217-1)  
[5091-3300E](#)
- Direct Characterization of Motion Control Systems (AN 1200-2)  
[5966-4475E](#)
- Disk Drive Servo-Track Writing with Laser Interferometers (AN 325-11)  
[5952-7984](#)
- Effective Multitap Transformer Testing Using a Scanner (AN 1224-5)  
[5091-6310E](#)
- Low-Level RF Leakage Measurements (AN 1204)  
[5952-2789](#)
- Magnetic Head Measurement Using a Constant Test Current—Agilent 4284A Application Information (AN 369-3)  
[5950-2951](#)
- Measurement of Capacitance Characteristics of Liquid Crystal Cell (AN 369-7)  
[5950-2994](#)

Non-Contact Measurements with Laser Interferometers Extractions on High-Power Devices Using the Agilent 4142B (AN 325-12)  
[5966-1989E](#)

Practical Strain Gauge Measurements (AN 290-1)  
[5952-8880](#)

Simplified Motor Spin-up Analysis (AN 1200-1) (AN 1200-1)  
[5966-4474E](#)

Submicron Positioning with the Agilent 5527A Laser Position Transducer System and Agilent 10936A Servo-Axis Board (AN 325-10)  
[5952-7942](#)

Synthesizing Magnetic Disk Read and Servo Signals with Agilent 8770A Arbitrary Waveform System (AN 314-2)  
[5954-6357](#)

Using Impedance Measurement to Evaluate Electronic Components and Materials—Agilent 4284A Application Information (AN 369-1)  
[5950-2949](#)

## VXI

Agilent E8491B IEEE-1394-to-VXI: Increasing Test System Throughput  
[5968-7237E](#)

Agilent Technologies E8758A Compact VXI Foundation System and I/O Modules  
[5968-9861EUS](#)

Agilent VXI Test System Signal Switching  
[5968-7234E](#)

## Vector Measurements

Exploring the Architectures of Network Analyzers  
[5965-7708E](#)

In-Fixture Measurements Using Vector Network Analyzers (AN 1287-9)  
[5968-5329E](#)

Pulsed Measurements with the Agilent 8720ES and 8753ES Network Analyzers (AN 1287-10)  
[5980-0798E](#)

S-Parameter Techniques for Faster, More Accurate Network Design (AN 95-1)  
[5952-1130](#)

Testing and Troubleshooting Digital RF Communications Receiver Designs  
[5968-3579E](#)

Understanding the Fundamental Principles of Vector Network Analysis  
[5965-7707E](#)

Vector Modulation Measurements/Coherent Pulsed Tests of Radar and EW Systems (AN 043-3)  
[5954-6366](#)

Vector Modulation Measurements—Measurement Applications for Digital Microwave Radio (AN 343-1)  
[5954-6365](#)

## Video/TV

Fast Characterization of Pulse-Width Encoded Data (AN 1200-5)  
[5966-4478E](#)

Mixing MPEG-II & ATM: Will It work?  
[5963-7511E](#)

Simplified Analysis of Phase-Locked Loop Capture and Tracking Range (AN 1200-7)  
[5966-4480E](#)

Video Elementary Stream Analyzer—E6310A  
[5965-6491E](#)

## Voltage-Controlled Oscillator

Simplified Analysis of Phase-Locked Loop Capture and Tracking Range (AN 1200-7)  
[5966-4480E](#)

## Voltage Regulators

Pulsed Characteristics of Power Semiconductors Using Electronic Loads (AN 1246)  
[5091-7636E](#)

Sequential Shunt Regulation (AN 1293)  
[5965-7329E](#)

## Wireless

10 Hints for Making Successful Noise Figure Measurements (AN 1341)  
[5980-0288E](#)

CDPD Testing—Agilent 8921A Option 502/3 or 602/3  
[5965-5187E](#)

Challenges in developing the deploying 3G systems  
[5980-1223E](#)

Characterizing Digitally Modulated Signals with CCDF Curves  
[5968-6875E](#)

Choosing the Right Average Power Sensor for Wireless Test  
[5968-7150E](#)

Considerations when selecting a System Power Supply for Mobile Communications Device Testing (AN 1310)  
[5968-2424E](#)

Designing and Testing 3GPP W-CDMA Base Stations (BS) (AN 1355)  
[5980-1239E](#)

Designing and Testing 3GPP W-CDMA User Equipment (UE) (AN 1356)  
[5980-1238E](#)

Designing and Testing cdma2000 Base Stations (AN 1357)  
[5980-1303E](#)

Designing and Testing cdma2000 Mobile Stations (AN 1358)  
[5980-1237E](#)

Digital Radio Theory and Measurements (AN 355)  
[5091-4777E](#)

Estimating Downlink Speech Quality with GSM Air Interface Measurements (AN 1343)  
[5980-0220E](#)

Examine Channel Switching Characteristics of Cellular Radios (AN 1200-10)  
[5966-4483 E](#)

Examine GMSK Modulation in GSM and PCN Mobile Communications Systems (AN 1200-11)  
[5965-9650E](#)

Generating Custom, Real-World Waveforms (AN 1360)  
[5980-2518EN](#)

HPSK Spreading for 3G  
[5968-8438E](#)

Measurements on Digital Modulation Components Requiring a Complex Stimulus (AN 1353)  
[5980-1337E](#)

Measuring EDGE Signals—New and Modified Techniques and Measurement Requirements (AN 1361)  
[5980-2508EN](#)

Optimizing VCO/PLL Evaluations and PLL Synthesizer Designs  
[5968-6772E](#)

Optimizing Your CDMA Wireless Network Today and Tomorrow Using Drive-Test Solutions (AN 1345)  
[5968-9916E](#)

Optimizing your GSM Network Today and Tomorrow (AN 1348-1)  
[5980-0218E](#)

Optimizing your TDMA Network Today and Tomorrow Using Drive-testing to Identify (AN 1349-1)  
[5980-0219E](#)

Peak Deviation and Center Frequency Measurements for CT2 and DECT Radios (AN 1200-12)  
[5966-4484 E](#)

Performing Bluetooth RF Measurements Today  
[5968-7746E](#)

Performing cdma2000 Measurements Today  
[5968-5858E](#)

Practical Noise Figure Measurement and Analysis for Low-Noise Amplifier Designs (AN 1354)  
[5980-1916E](#)

Simple Analysis of Frequency Modulation (AN 1200-6)  
[5966-4479 E](#)

Simplified Analysis of Phase-Locked Loop Capture and Tracking Range (AN 1200-7)  
[5966-4480 E](#)

Simplified Filter Tuning Using Time Domain (AN 1287-8)  
[5968-5328E](#)

Testing and Troubleshooting Digital RF Communications Receiver Designs (AN 1314)  
[5968-3579E](#)

Testing and Troubleshooting Digital RF Communications Transmitter Designs (AN 1313)  
[5968-3578E](#)

Testing CDMA Base Station Amplifiers (AN 1307)  
[5967-5486E](#)

Testing GPRS and Manufacturing (AN 1362)  
[5980-2646EN](#)



- Understanding CDMA Measurements for Base Stations and Their Components (AN 1311)  
5968-0953E
- Understanding GSM Transmitter Measurements for Base Transceiver Stations and Mobile Stations (AN 1312)  
5968-2320E
- Understanding IP Analysis  
5980-1708E
- 1**
- (AN 1) DS3 Network Interface Unit  
5963-9927EUS
- (AN 1200-1) Simplified Motor Spin-up Analysis  
5966-4474E
- (AN 1200-10) Examine Channel Switching Characteristics of Cellular Radios  
5966-4483E
- (AN 1200-11) Examine GMSK Modulation in GSM and PCN Mobile Communications Systems  
5965-9650E
- (AN 1200-12) Peak Deviation and Center Frequency Measurements for CT2 and DECT Radios  
5966-4484E
- (AN 1200-2) Direct Characterization of Motion Control Systems  
5966-4475E
- (AN 1200-3) VCO Step Response Analysis Made Easy  
5966-4476E
- (AN 1200-4) Quick Identification of Periodic Jitter Sources  
5966-4477E
- (AN 1200-5) Fast Characterization of Pulse-Width Encoded Data  
5966-4478E
- (AN 1200-6) Simple Analysis of Frequency Modulation  
5966-4479E
- (AN 1200-7) Analysis of Phase-Locked Loop Capture and Tracking Range  
5966-4480E
- (AN 1200-8) Single Shot Frequency Profiling of Chirped Radars Made Easy  
5966-4481E
- (AN 1200-9) Histograms Simplify Analysis of Random Jitter  
5966-4482E
- (AN 1201-2) Hierarchical Modeling for Circuit Characterization  
5091-1668E
- (AN 1204) Low-Level RF Leakage Measurements  
5952-2789
- (AN 1211-2) Testing n x 64 kb/s Services  
5091-2069E
- (AN 1211-3) Testing Sub-rate Data Services  
5091-2072E
- (AN 1212) Characterizing Components with a Microwave Tracking Source  
5091-2172E
- (AN 1217-1) Basics of Measuring the Dielectric Properties of Materials  
5091-3300E
- (AN 1224-3) Effective Transformers/LF Coils Testing  
5091-4134E
- (AN 1224-5) Effective Multitap Transformer Testing Using a Scanner  
5091-6310E
- (AN 123) Floating Measurements and Guarding  
5952-2153
- (AN 1237-1) Maximizing Revenue with In-Service Testing: Introduction  
5091-6009E
- (AN 1237-2) Maximizing Revenue with In-Service Testing—Centralized Testing/Monitoring Systems  
5091-6349E
- (AN 1239) Effective Multitap Transformer Testing Using a Scanner  
5091-6310E
- (AN 1240) Microprobing with the MTS-2200 Fine Pitch Probing System  
5091-6148E
- (AN 1246) Pulsed Characteristics of Power Semiconductors Using Electronic Loads  
5091-7636E
- (AN 1258) Evaluating Tributary Jitter from the SDH Network  
5962-9551E
- (AN 1260-1) Combining Network and Spectrum Analyses and IBASIC to improve device characterization and test time  
5965-7656E
- (AN 1267) Frequency Agile Jitter Measurement System  
5963-5353E
- (AN 1273) Compliance Testing to the IEC 1000-3-2 and (EN 61000-3-2) and IEC 1000-3-3 (EN 61000-3-3) Standards  
5964-1917E
- (AN 1287-1) Understanding the Fundamental Principles of Vector Network Analyzers  
5965-7707E
- (AN 1287-2) Exploring the Architectures of Network Analyzers  
5965-7708E
- (AN 1287-3) Applying Error Correction to Network Analyzer Measurements  
5965-7709E
- (AN 1287-4) Network Analyzer Measurements: Filter and Amplifier Examples  
5965-7710E
- (AN 1287-5) Improving Throughput in Network Analyzer Applications  
5966-3317E
- (AN 1287-6) Using a Network Analyzer to Characterize High-Power Components  
5966-3319E
- (AN 1287-7) Improving Network Analyzer Measurements of Frequency-Translating Devices  
5966-3318E
- (AN 1287-8) Simplified Filter Tuning Using Time Domain  
5968-5328E
- (AN 1287-9) In-Fixture Measurements Using Vector Network Analyzers  
5968-5329E
- (AN 1287-10) Pulsed Measurements with the Agilent 8720ES and 8753ES Network Analyzers  
5980-0798E
- (AN 1288-4) How to Characterize CATV Amplifiers Effectively  
5965-9434E
- (AN 1289) The Science of Timekeeping  
5965-7984E
- (AN 1290-1) Cookbook for EMC Precompliance Measurements  
5964-2151E
- (AN 1291-1) 8 Hints for Making Better Network Analyzer Measurements  
5965-8166E
- (AN 1293) Sequential Shunt Regulation  
5965-7329E
- (AN 1295) Riding the Internet Wave: Ensuring Safe, Solid Internet Services for the Enterprise  
5965-9371
- (AN 1299) Introduction to BER Testing of WDM Systems  
5966-0911E
- (AN 1300-3) Permittivity Measurements of PC Board and Substrate Materials Using the Agilent 4291B and Agilent 16453A  
5966-1847E
- (AN 1300-4) Permeability Measurements Using the Agilent 4291B and Agilent 1654A  
5966-1844E
- (AN 1300-5) Electronic Characterization of IC Package  
5966-1849E
- (AN 1300-6) Impedance Characterization of Magneto-Resistive Disk Heads  
5966-1096E
- (AN 1300-7) On-Chip Semiconductor Device Impedance Measurements Using the Agilent 4291B  
5966-1845E
- (AN 1300-8) Dielectric and Magnetic Material Characterization with the Novocontrol Concept 60 System  
5968-4491E
- (AN 1301) Effective Spectrum Analysis Testing for Consumer Electronics Production Lines  
5966-0367E
- (AN 1302) Making Radiated and Conducted Compliance Measurements with EMI Receivers  
5966-2915E
- (AN 1303) Spectrum Analyzer Measurements and Noise  
5966-4008E
- (AN 1304-1) Evaluating Microstrip with Time Domain Reflectometry  
5968-0007E
- (AN 1304-2) Time Domain Reflectometry Theory  
5966-4855E

Many of these documents are orderable and downloadable from Agilent's web site:

[www.agilent.com/find/apps](http://www.agilent.com/find/apps)

- (AN 1304-3) Microprobing with the Agilent 54750 Oscilloscope  
[5968-0773E](#)
- (AN 1304-4) Measuring Characteristic Impedance of Short Rambus Motherboard Traces and Small-Outline RIMMs  
[5968-9146E](#)
- (AN 1305-1) Contact Resistance and Insulation Resistance Measurements of Electro-mechanical Components  
[5968-0325](#)
- (AN 1305-2) Insulation Resistance Measurement of the Plate Type Materials  
[5968-3400E](#)
- (AN 1305-3) Effective Transformer/LF Coil Testing  
[5967-5377E](#)
- (AN 1305-4) Effective Electrolytic Capacitor Testing  
[5967-5378E](#)
- (AN 1306-1) 8 Hints for Making Better Measurements Using Analog RF signal Generators  
[5967-5661E](#)
- (AN 1307) Testing CDMA Base Station Amplifiers  
[5967-5486E](#)
- (AN 1308-1) Network, Spectrum, and Impedance Evaluation of Electronic Circuits and Components  
[5967-5942E](#)
- (AN 1309) Pulsed Carrier Phase Noise Measurements  
[5968-2081E](#)
- (AN 1310) Considerations when Selecting a System Power Supply for Mobile Communications Device Testing  
[5968-2424E](#)
- (AN 1311) Understanding CDMA Measurements for Base Stations and Their Components  
[5968-0953E](#)
- (AN 1312) Understanding GSM Transmitter Measurements for Base Transceiver Stations and Mobile Stations  
[5968-2320E](#)
- (AN 1313) Testing and Troubleshooting Digital RF Communications Transmitter Designs  
[5968-3578E](#)
- (AN 1314) Testing & Troubleshooting Digital RF Communications Receiver Designs  
[5968-3579E](#)
- (AN 1316) Optimizing Spectrum Analyzer Amplitude Accuracy  
[5968-3659E](#)
- (AN 1318) Optimizing Spectrum Analyzer Measurement Speed  
[5968-3411E](#)
- (AN 1319) Compliance Testing IEC/EN 61000-4-8  
[5968-3730E](#)
- (AN 1320) Agilent Internet Advisor Troubleshooting VoIP Signaling  
[5968-4450E](#)
- (AN 1321) Testing Standard and CRC-4 2.048 Mb/s Systems  
[5968-4518E](#)
- (AN 1323) Troubleshooting Frame Relay  
[5968-5310E](#)
- (AN 1324) Understanding PDC and NADC Transmitter Measurement for Base Transceiver Stations and Mobile Stations  
[5968-5537E](#)
- (AN 1326) 8 Hints for Solving Common Debugging Problems with Your Logic Analyzer  
[5968-5700E](#)
- (AN 1327) Basic ATM Troubleshooting with the Agilent Internet Advisor  
[5968-5924E](#)
- (AN 1328) Cookbook for EMC Precompliance Measurements  
[5968-3661E](#)
- (AN 1336) Ethernet/Fast Ethernet Problems and Solutions  
[5968-8428E](#)
- (AN 1337) Feeling Comfortable with Logic Analyzers  
[5968-8291E](#)
- (AN 1340-1) Characterizing High-Speed Optical Transmitters Compliance Testing with the Agilent 86100A Infiniium DCS  
[5968-9249E](#)
- (AN 1341) 10 Hints for Making Successful Noise Figure Measurements  
[5980-0288E](#)
- (AN 1343) Estimating Downlink Speech Quality with GSM Air Interface Measurements  
[5980-0220E](#)
- (AN 1345) Optimizing Your CDMA Wireless Network Today and Tomorrow Using Drive-Test Solutions  
[5968-9916E](#)
- (AN 1346) Dual Simultaneous Measurements  
[5980-0547E](#)
- (AN 1348-1) Optimizing your GSM Network Today and Tomorrow  
[5980-0218E](#)
- (AN 1349-1) Optimizing your TDMA Network Today and Tomorrow Using Drive-testing to Identify  
[5980-0219E](#)
- (AN 1350) Debugging Modem Power Electronics: Seeing the Whole Picture  
[5980-0797EUS](#)
- (AN 1351) Agilent Technologies 54622D 12C Debugging  
[5980-0796EUS](#)
- (AN 1352) Agilent Technologies 54622S MSO and CEBus PL Comm  
[5980-0794EUS](#)
- (AN 1354) Practical Noise Figure Measurement and Analysis for Low-Noise Amplifier Designs  
[5980-1916E](#)
- (AN 1353) Measurements On Digital Modulation Components Requiring A Complex Stimulus  
[5980-1337E](#)
- (AN 1355) Designing and Testing 3GPP W-CDMA Base Stations (BS)  
[5980-1239E](#)
- (AN 1356) Designing and Testing 3GPP W-CDMA User Equipment (UE)  
[5980-1238E](#)
- (AN 1357) Designing and Testing cdma2000 Base Stations  
[5980-1303E](#)
- (AN 1358) Designing and Testing cdma2000 Mobile Stations  
[5980-1237E](#)
- (AN 1359) Telegra D and m Fax System  
[5980-2196E](#)
- (AN 1360) Generating Custom, Real-World Waveforms  
[5980-2518EN](#)
- (AN 1361) Measuring EDGE Signals—New and Modified Techniques and Measurement Requirements  
[5980-2508EN](#)
- (AN 1362) Testing GPRS and Manufacturing  
[5980-2646EN](#)
- (AN 150) Spectrum Analyzer Basics  
[5952-0292](#)
- (AN 150-1) Spectrum Analysis AM and FM  
[5954-9130](#)
- (AN 154) S-Parameter Design  
[5952-1087](#)
- (AN 1550-2) An Introduction to Error Location Analysis  
[5980-0648E](#)
- (AN 1550-6) High-Speed Lightwave Component Analysis  
[5091-6478E](#)
- (AN 1550-8) Measuring Extinction Ratio of Optical Transmitters  
[5966-4316E](#)

## 2

- (AN200) Fundamentals of the Electronic Counters  
[5965-7660E](#)
- (AN200-1) Fundamentals of Microwave Frequency Counters  
[5965-7661E](#)
- (AN200-2) Fundamentals of Quartz Oscillators  
[5965-7662E](#)
- (AN200-3) Fundamentals of Time Interval Measurements  
[5965-7663E](#)
- (AN200-4) Understanding Frequency Counter Specifications  
[5965-7664E](#)
- (AN238) Semiconductor Measurements with the Agilent 4140B Picoammeter/DC Voltage Source  
[5952-8840](#)
- (AN238-1) Ultra Low Current Semiconductor DC Parameter Measurement System Using Agilent 4140B  
[5952-8873](#)
- (AN243) Fundamentals of Signal Analysis  
[5952-8898E](#)
- (AN243-3) The Fundamentals of Modal Testing  
[5954-7957E](#)
- (AN243-7) Bearing Runout Measurements  
[5965-5387E](#)
- (AN250-2) Battery Charging/Discharging  
[5952-4033](#)
- (AN283-2) External Frequency Doubling of the Agilent 8662A Synthesized Signal Generator  
[5952-8217](#)
- (AN283-3) Low Phase Noise Applications of the Agilent 8662A and 8663A Synthesized Signal Generators  
[5953-8435](#)
- (AN290) Practical Temperature Measurements  
[5965-7822E](#)
- (AN 290-1) Practical Strain Gauge Measurements  
[5952-8880](#)

**3**

- (AN 314-2) Synthesizing Magnetic Disk Read and Servo Signals with Agilent 8770A Arbitrary Waveform System  
5954-6357
- (AN 314-5) A Guide to Microwave Upconversion  
5953-2342
- (AN 317) Practical Design and Evaluation of High-Frequency Circuits  
5953-6910
- (AN 325-10) Submicron Positioning with the Agilent 5527A Laser Position Transducer System and Agilent 10936A Servo-Axis Board  
5952-7942
- (AN 325-11) Disk Drive Servo-Track Writing with Laser Interferometers  
5952-7984
- (AN 325-12) Non-Contact Measurements with Laser Interferometers  
5966-1989E
- (AN 327-1) Extending Dynamic Range of Scalar Transmission Measurements Using the Agilent 8757A, 8756A, or 8755C Scalar Network Analyzers  
5953-8882
- (AN 339-20) Role of DC Parametric Test in High Speed Digital  
5952-7936
- (AN 339-4) Measuring the Characteristic Impedance of Balanced Cables  
5950-2918
- (AN 343-1) Vector Modulation Measurements: Measurement Applications for Digital Microwave Radio  
5954-6365
- (AN 343-2) Dynamic Component Test Using Vector Modulation Analysis  
5954-6367
- (AN 343-4) Measuring Demodulator Image Rejection Using the Agilent 8980A Vector Analyzer  
5952-3703
- (AN 343-6) Testing Digital MW Receivers with a Calibrated Source  
5952-0800
- (AN 345-1) Amplifier Measurements Using the Scalar Network Analyzer  
5954-1599
- (AN 346) A Guideline For Designing External DC Bias Circuits  
5950-2912
- (AN 346-2) Balanced Circuit Measurement with an Impedance Analyzer/LCR Meter/ Network Analyzer  
5091-4480E
- (AN 346-3) Effective Impedance Measurement Using OPEN/SHORT/LOAD Correction  
5091-6553E
- (AN 346-4) 8 Hints for Successful Impedance Measurement  
5968-1947E
- (AN 355) Digital Radio Theory and Measurements  
5091-4777E
- (AN 355A) Digital Radio Theory and Measurements  
5091-4777E
- (AN 356-1) Techniques and Applications for High Throughput and Stable Characterization  
5950-2954
- (AN 357-1) Network, Spectrum, and Impedance Evaluation of IF Circuits—Agilent 4195A Network/Spectrum Analyzer  
5950-2931
- (AN 369-1) Using Impedance Measurement to Evaluate Electronic Components and Materials—Agilent 4284A Application Information  
5950-2949
- (AN 369-3) Magnetic Head Measurement Using a Constant Test Current—Agilent 4284A Application Information  
5950-2951
- (AN 369-5) Multifrequency C-V Measurements of Semiconductors: Agilent 4284A Application Information  
5950-2953
- (AN 369-6) Impedance Testing Using a Scanner with the Agilent 54120 Family of Digitizing Oscilloscopes  
5950-2975
- (AN 369-7) Measurement of Capacitance Characteristics of Liquid Crystal Cell  
5950-2994
- (AN 369-8) Wide-Range DC Current Biased Inductance Measurement  
5950-2367
- (AN 369-9) Improve Electronic Product Quality and Performance With Agilent Precision LCR Meters  
5090-0233
- (AN 369-10) High Accuracy and Fast RF Inductor Testing  
5091-1596E
- (AN 369-12) Measurement of Impedance of Magnetic Head  
5965-6663E
- (AN 371) Lightwave Measurements with the Agilent 71400 Lightwave Signal Analyzer  
5954-9137E
- (AN 372-2) Battery Testing  
5952-4191
- (AN 376-1) Biasing Three-Terminal Devices for Test  
5952-4193
- (AN 377-1) Automatic Frequency Profiling of Chirped Radar Pulses Using the Agilent 5361A/B Pulse/CW Microwave Counter  
5952-7987
- (AN 377-2) Automated Characterization of Microwave VCOs Using the Agilent 5361A/B Pulse/CW Microwave Counter  
5952-7988
- (AN 377-3) Frequency Profiling Without a Pulse Generator  
5952-7991
- (AN 379-2) Measuring Microwave Radio Antenna Return Loss Using the Agilent 11758T Digital Radio Test System  
5959-8749
- (AN 382-1) The Agilent 4062UX Provides High Performance Data Management and Powerful Networking Capabilities (Transfer Data to BD/DA System)  
5950-2393
- (AN 383-1) Simplification of DC Characterization and Analysis of Semiconductor Devices  
5950-2396
- (AN 386) Pulsed Carrier Phase Noise Measurements Using the Agilent 3048A Phase Noise Measurement System  
5951-6743
- (AN 387) High Productivity Measurements in Digital Transmission  
5959-7898
- (AN 388) Signal Generator  
5952-2019

**4**

- (AN 4062-2) Precision Evaluation of Flash Memory Cells  
[5091-6806E](#)
- (AN 4070-1) Ultra Low Current DC Characterization at the Wafer Level  
[5965-7352E](#)
- (AN 4070-2) Accurate Capacitance Characterization at the Wafer Level  
[5968-2499E](#)
- (AN 4070-3) Accurate and Efficient Frequency Evaluation of a Ring Oscillator  
[5968-4310E](#)
- (AN 4156-1) Ultra Low Current DC Characterization of MOSFETs at the Wafer Level  
[5963-2014E](#)
- (AN 4156-2) Automated Extraction of Semiconductor Parameters Using the Agilent 4155A/4156A  
[5963-1249E](#)
- (AN 4156-3) Evaluation of Hot Carrier Induced Degradation of MOSFET Devices  
[5963-1111E](#)
- (AN 4156-4) Evaluation of Flash Memory Cells  
[5965-5657E](#)
- (AN 4156-5) Measurement of Power Devices Using External DC Power Supply  
[5963-2365E](#)

- (AN 4156-6) Maximizing the Incoming Inspection Efficiency of Semiconductor Devices  
[5963-2364E](#)
- (AN 4156-7) Evaluation of Electromigration Using the SWEAT Procedure  
[5963-1110E](#)
- (AN 4156-8) Evaluation of Oxide Reliability Using V-Ramp/ J-Ramp Test  
[5963-1248E](#)
- (AN 4156-9) Evaluation of the Surface State Using Charge Pumping Methods  
[5964-2195E](#)
- (AN 43-3) Vector Modulation Measurements/Coherent Pulsed Tests of Radar and EW Systems  
[5954-6366](#)

**5**

- (AN 57-2) Noise Figure Measurement Accuracy  
[5952-3706](#)

**6**

- (AN 64-1B) Fundamentals of RF and microwave Power Measurements  
[5965-6630E](#)
- (AN 64-4B) 4 Steps for Making Better Power Measurements  
[5965-8167E](#)

**8**

- (AN 8 644-2) VOR/ILS Testing with Agilent 8644A  
[5951-6740](#)

**9**

- (AN 90B) DC Power Supply Handbook  
[5952-4020](#)
- (AN 95-1) S-Parameter Techniques for Faster, More Accurate Network Design  
[5952-1130](#)

**E**

- (AN E5250A-1) Low Current Measurement with Agilent E5250A Switch Mainframe  
[5964-9112E](#)
- (AN E5250A-2) Evaluation of Hot Carrier Induced Degradation of MOSFET Devices Application Flyer  
[5964-9113E](#)
- (AN E5250A-3) Accurate and Efficient C-V Measurements  
[5965-5658E](#)

**G**

- (AN G002) DC Parametric Analysis of Semiconductor Devices  
[5950-2928](#)



**Additional Entries without Application Note Numbers**

- 10/100Base-T Testing  
[5968-5053E](#)
- 10-Megasample-per-Second Analog-to-Digital Converter with Filter and Memory/  
Agilent E1430A  
[5962-9497E](#)
- 4 Steps for Making Better Power Measurements  
[5965-8167E](#)
- 8 Hints for Common Debugging Problems with Your Logic Analyzer  
[5968-5700E](#)
- 8 More Hints for making Better Scope Measurements  
[5968-8756E](#)
- A Quality Test Demands A Quality Fixture  
[5965-6624E](#)
- ABR Technology Overview and Testing Challenges  
[5968-1234E](#)
- Accurate and Efficient C-V Measurements  
[5965-5658E](#)
- Accurate and Effective Flash Memory Cell Evaluation Using the Agilent 4072A  
[5968-6719E](#)
- ADSL Line Qualification and Troubleshooting with the Service Advisor 2 MHz TIMS Module  
[5968-3731E](#)
- ADSL Line Qualification and Troubleshooting with N1626A  
[5968-3923E](#)
- Advanced Testing Techniques for ATM Service Level Agreements  
[5968-6560E](#)
- Agilent E8491B IEEE-1394-to-VXI: Increasing Test System Throughput  
[5968-7237E](#)
- Agilent 4155A/4156A Semiconductor Parameter Analyzer—Edition 1 Programming Guide for Agilent 4145A/B Users  
[5963-3201E](#)
- Agilent 6800 Series AC Power Source/Analyzer  
[5963-7044E](#)
- Agilent BASIC for Windows  
[5964-6019E](#)
- Agilent EPM Series, Agilent 437B or Agilent 438A Compatibility  
[5968-4519E](#)
- Agilent Technologies E8758A Compact VXI Foundation System and I/O Modules  
[5968-9861EUS](#)
- Agilent Technologies ParBERT 81250, Mux/Demux Application  
[5968-9695E](#)
- Agilent TS-5400 Series II Remote Keyless Entry Application  
[5968-6080E](#)
- Agilent TS-5400 Series II Supplemental Restraint Systems  
[5968-6356E](#)
- Agilent VXI Test System Signal Switching  
[5968-7234E](#)
- ATM Forum Conformance Testing to Ensure Your P-NNI Implementation is Ready to Plug-and-Play  
[5966-1004E](#)
- ATM Forum European Update  
[5964-4147E](#)
- Automated Extraction of Semiconductor Parameters Using the Agilent 4155B/4156B  
[5963-1249E](#)
- Automatic Frequency Settling Time Measurement Speeds Time-to-Market for RF Designs  
[5964-4335E](#)
- Bearing Runout Measurements  
[5965-5387E](#)
- Beginner's Guide to Using the Agilent 8146A Optical Time Domain Reflectometer  
[5964-6672E](#)
- Building Complex ATE Systems Using New Software Technologies  
[5968-5936E](#)
- CDPD Testing—Agilent 8921A Option 502/3 or 602/3  
[5965-5187E](#)
- Challenges in developing the deploying 3G systems  
[5980-1223E](#)
- Characterizing Digitally Modulated Signals with CCDF Curves  
[5968-6875E](#)
- Characterizing Communications ICs With The Agilent 83000 Model F660  
[5962-9273EUS](#)
- Combining Network and Spectrum Analysis and IBASIC to Improve Device Characterization and Time Set  
[5965-7656E](#)
- Commissioning and Testing Echo Canceller Equipment with The T1/E1 Test Advisor  
[5968-3294E](#)
- Complete Analysis of Erbium-Doped Fiber Amplifiers  
[5965-0976E](#)
- Conformance Testing—An Essential Part of SDH Deployment  
[5965-1020E](#)
- Conformance Testing and Essential Part of SONET Deployment  
[5965-1432E](#)
- Connect Check Backgrounder  
[5965-5092E](#)
- Connecting Agilent Technologies Test Sets for In-Service Testing of PDH/SDH Networks  
[5965-5898E](#)
- Designing Packet over SONET/SDH (POS) Hardware  
[5968-1614E](#)
- Digital Modulation In Connection Systems—An Introduction  
[5965-7160E](#)
- Digital Video Testing with the Agilent 16542A  
[5091-5447E](#)
- Distributed Emulation for Toshiba R3900 Family  
[5965-1529E](#)
- Eight Hints for Making Better Spectrum Analyzer Measurements  
[5965-7009E](#)
- Evaluating Chip Inductors Using the Agilent 4291B  
[5966-1848](#)
- Examine GMSK Modulation in GSM and PCN Mobile Communications Systems  
[5965-9650E](#)
- Exploring the Architectures of Network Analyzers  
[5965-7708E](#)
- Functional Testing of ATM Signaling Protocols  
[5965-9331E](#)
- Getting the Most Out of Your T1 and DDS Services  
[5091-6174E](#)
- Highly Accurate Evaluation of Chip Capacitors using the Agilent 4291B  
[5966-1850E](#)
- High-Speed BER Testing of SDH Components and Sub-Systems  
[5091-4799E](#)
- HPSK Spreading for 3G 5968-8438E Impedance Measurements...in Brief  
[5964-3558E](#)
- Implementing ATM Signaling: Avoiding the Interoperability Pitfalls  
[5963-7514E](#)
- In-Depth Characterization of Optical Components  
[5965-5286E](#)
- Interference in IS-136 TDMA  
[5980-0219E](#)
- Internet Protocol Quality of Service  
[5968-9722E](#)
- Internet Routing Protocol Testing  
[5968-9391E](#)
- Introduction to Agilent Standard Instrument Control Library  
[5963-2228E](#)
- Locating Errors in Gigabit Transmission Systems and Components  
[5963-2005E](#)
- Low Current Measurement with Agilent E65250A Switch Mainframe  
[5964-9112E](#)

- Low Phase Noise Applications of the Agilent 8662A and 8663A Synthesized Signal Generators  
[5953-8435](#)
- Maximizing the Incoming Inspection Efficiency of Semiconductor Devices  
[5963-2364E](#)
- Measurement of Power Devices Using External DC Power Supply  
[5963-2365E](#)
- Measurements On Digital Modulation Components Requiring a Complex Stimulus  
[5980-1337E](#)
- Measuring Demodulator Image Rejection Using the Agilent 8980A Vector Analyzer  
[5952-3703](#)
- Memory Test Software Provides Cost-Effective Solutions to Testing Advanced SRAMs  
[5963-5078E](#)
- Mixing MPEG-II & ATM: Will It work?  
[5963-7511E](#)
- Multi Protocol Label Switching  
[5980-1225E](#)
- NNI Signalling Test Software Helps Ensure Seamless ATM Networks  
[5965-6307E](#)
- Operating LANs in an ATM Environment  
[5963-7513E](#)
- Optical Spectrum Analysis Basics  
[5963-7145E](#)
- Optimizing Spectrum Analyzer Dynamic Range  
[5968-4545E](#)
- Optimizing VCO/PLL Evaluations and PLL Synthesizer Designs  
[5968-6772E](#)
- PCI Timing Check Using the Agilent E2920 PCI Series Exerciser/Analyzer  
[5968-5816E](#)
- Performing Bluetooth RF Measurements Today  
[5968-7746E](#)
- Performing cdma2000 Measurements Today  
[5968-5858E](#)
- POS Router Latency Testing  
[5968-9724E](#)
- Precision Time-Domain Measurement Using the Agilent E1430A  
[5962-0015E](#)
- Protocol Testing With PT Series Protocol Testers  
[5962-9408EUS](#)
- Pulse Testing 980-nm Pump Laser-Diodes in Optical Fiber  
[5963-6988E](#)
- Reducing Process Defect Escapes with Vectorless Test  
[5965-5092E](#)
- SEMI S2 Standard Modifications for Agilent 3070 and Related Equipment  
[5980-0941E](#)
- Signaling Performance Case Studies using the Agilent Multiport UNI Signaling Performance Test Solution  
[5968-1235E](#)
- SS7 Protocol Testing With PT Series Protocol Testers  
[5962-9408EUS](#)
- System Test with Localized RT-DSP  
[5966-3342E](#)
- Testing Amplifiers and Active Devices with the Agilent 8510 Network Analyzer  
[5963-2352E](#)
- Testing and Troubleshooting Digital RF Communications Receiver Designs  
[5968-3579E](#)
- Testing ATM at 622 Mb/s and Above  
[5965-9333E](#)
- Testing ATM Interoperability  
[5965-9334E](#)
- Testing ATM Signaling Performance  
[5965-9330E](#)
- Testing for GFR QoS Eligibility and Frame-based Statistics  
[5980-0565E](#)
- Testing Operation and Maintenance (OAM) Implementations for ATM  
[5965-9332E](#)
- Testing QoS, OAM, Policing, and Performance at 622 Mb/s and 2.4 Gb/s  
[5968-1237E](#)
- Testing Techniques for Next Generation IP Networks  
[5968-1236E](#)
- Testing to Ensure Your P-NNI Implementation is Ready to Plug-and-Play  
[5966-1004E](#)
- The Dynamic Range Benefits of Large Scale Dithered Analog-to-Digital Conversion in the Agilent 89410A and 89440A  
[5091-7668E](#)
- The Personal Handy Phone System in Japan's Wireless Communication Market  
[5964-6753E](#)
- The Quest for Quality: The ATM Impairment Testing Handbook  
[5965-4992E](#)
- Traffic Policing  
[5963-7510E](#)
- Transport Stream Packet Timestamping—a Fundamental Necessity for MPEG Testing  
[5968-2015E](#)
- Troubleshooting 8-bit MCU-Based Designs Using the Agilent 54645D Mixed Signal Oscilloscope  
[5966-1080EE](#)
- Troubleshooting VoIP Signaling  
[5968-4450E](#)
- True Router Performance Testing  
[5980-1421E](#)
- TS5400 Series II Antilock Brakes & Traction Control Application  
[5968-6079E](#)
- Understanding IP Analysis  
[5980-1708E](#)
- Understanding the Fundamental Principles of Vector Network Analysis  
[5965-7707E](#)
- Vectorless Test Purchaser's Guide  
[5965-0805E](#)
- Verifying and Evaluating Gigabit Switch/Routers Performance with Internet-Scale Simulation  
[5968-1233E](#)
- Video Elementary Stream Analyzer—E6310A  
[5965-6491E](#)
- WAN Interworking with ATM  
[5963-7512E](#)
- What is Route Convergence?  
[5980-1224E](#)
- What is Routing Instability?  
[5980-1226E](#)

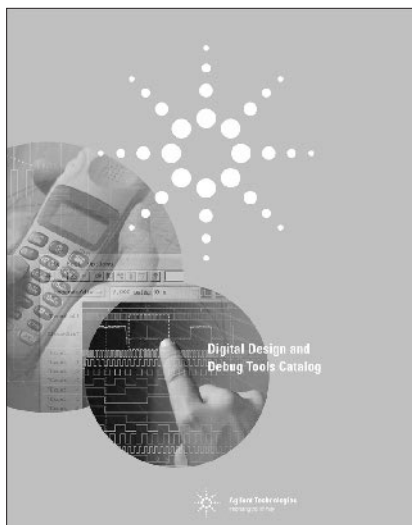

### Digital Design and Debug Tools 5968-9327E

This catalog contains product information, specifications and pricing for Agilent's logic analysis and emulation solutions, mixed-signal and high performance oscilloscopes, data generator, PCI exerciser, and pulse generators.

Digital designers may subscribe to the catalog to ensure that they are kept up-to-date on the latest digital debug solutions available from Agilent.

*To order any specialty catalog or directory, complete and return the business reply card at the end of this catalog.*

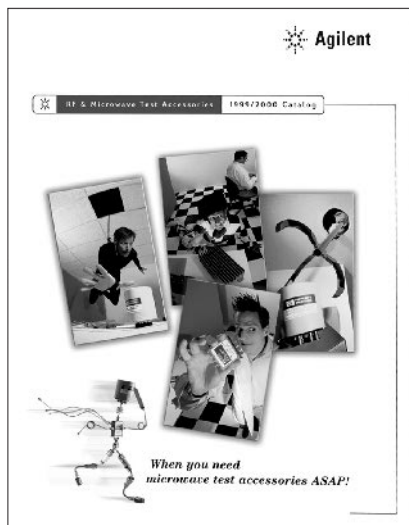

### RF and Microwave Test Accessories Catalog 5968-4314EN

This catalog contains general purpose RF and microwave accessories for test and measurement applications. Products featured in this catalog include amplifiers, attenuators, couplers, detectors, network analyzer accessories and cal kits, sensors, switches, waveguide, and a variety of other products.

Large sections are prefaced with an applications discussion, key specification description, and product family overview. Detailed specifications, drawings, indexes, and photographs are provided for a wide array of accessories.

View the online version of the RF and Microwave Test Accessories Catalog or order a printed copy of the catalog from our web site: [www.agilent.com/find/mta\\_catalog](http://www.agilent.com/find/mta_catalog)

For updated information and new services, visit Agilent's web site:

[www.agilent.com/find/tmcatalogs](http://www.agilent.com/find/tmcatalogs)

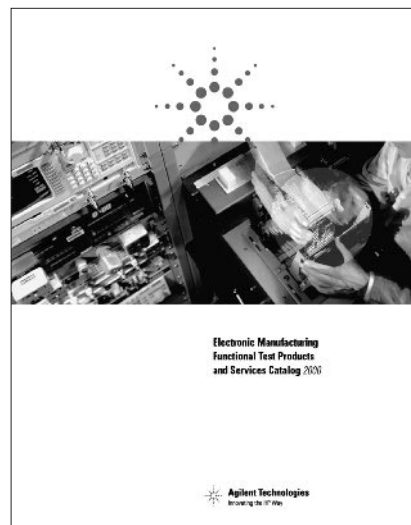

### Electronic Manufacturing Functional Test Products and Services Catalog 5980-0996E/EN

The new Electronic Manufacturing Functional Test Catalog offers the industry's broadest selection of instrumentation for building functional test systems – systems that boost your manufacturing throughput while helping lower repair and warranty costs through better test. With the new catalog, you now have the information you need to build your own test system for applications from wireless to automotive products and other products in between.

In addition to product information, the Electronic Manufacturing Functional Test Catalog also provides you with important information about services, support, and consulting that can help you achieve your business goals. Additional information is available about the Solution Providers Program Agilent has to help you get the most from your test systems.

The Agilent web site ([www.agilent.com/go/manufacturing](http://www.agilent.com/go/manufacturing)) is a great companion to the catalog providing full specifications for the featured products as well as application notes and service and support information.

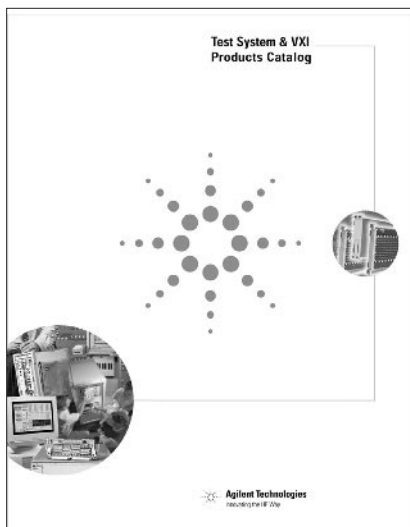

### Test System and VXI Products Catalog and CD-ROM 5980-0307E

The new Test System and VXI Products catalog covers Agilent's extensive line of VXI products for modular, scalable, and upgradable test systems. Learn more about the latest VXI applications, software, interfaces, controllers, mainframes, hardware, and more. Accompanying the catalog is a CD-ROM with all the product data sheets, product family overviews, product family specifications tables, power supplies overview, tutorials, instrument drivers tables, environmental specifications and warranty information. Visit the Agilent VXI web site at: [www.agilent.com/find/vxi](http://www.agilent.com/find/vxi)

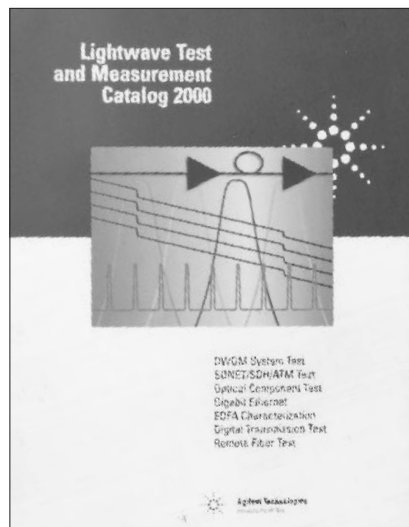

### Lightwave Test and Measurement Catalog 5980-8000E

The Agilent Technologies' Lightwave Test and Measurement catalog offers extensive lightwave product and application information. Whatever your needs for lightwave test equipment, it's all here:

- Multimeters
- Multi-wavelength meters
- Tunable lasers
- Optical spectrum analyzers
- Component analyzers
- Signal analyzers
- Polarization analyzers
- Error performance analyzers
- Communication performance analyzers
- Sources and receivers
- Timing generators
- Handheld instruments
- Systems
- Switches
- Converters
- General accessories

The catalog also contains tutorials on wavelength, power, polarization, return loss, waveform, and frequency and time-domain measurements. Other subjects covered include error performance analysis, optical amplifier testing, testing dense wavelength division multiplexing (DWDM) components, fiber-optic network installation and field service tests, and related accessories and adapters.

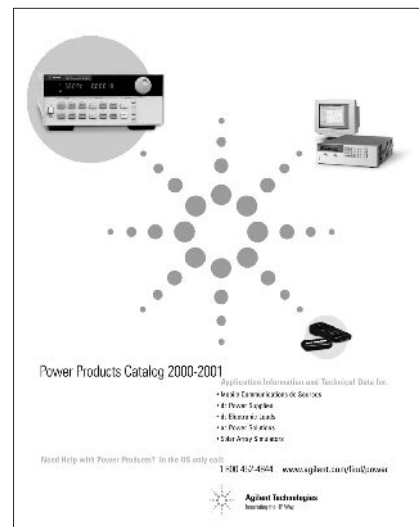

### Power Products Catalog 2000-2001 5968-2199E/EN

Agilent's entire line of power supplies, electronic loads, modular power systems, ac power sources, and solar array simulators are featured in this catalog. New products, such as the 66319B/D and 66321B/D mobile communications dc sources, the new 6800 high power ac sources, the N3300A fast throughput electronic load family, and the new economical E3640A power supplies for manufacturing test are included. Product selection and feature tables, complete product specifications, dimension drawings, and application information help you make the right choice of power products for your applications.

This year's catalog is viewable and can be downloaded from our web site: [www.agilent.com/find/power](http://www.agilent.com/find/power)



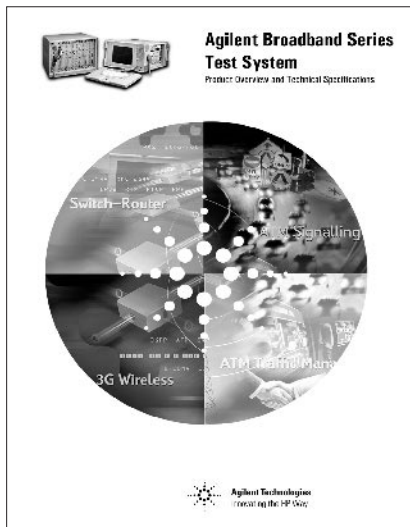

**Broadband Series Test System  
Product Information & Technical  
Specifications**  
**5966-0035E**

This catalog clearly shows the full depth and breadth of the Agilent Broadband Series Test System, the industry-standard ATM/IP test system for R&D engineering, product development, field trials, and QA testing. The Agilent BSTS is a modular system designed so that you can expand your system as your testing needs evolve.

Included in the catalog are the technical specifications and product information for each BSTS hardware and software module, as well as the Broadband Communications Map, product listings and an index of available related literature such as application and solution notes.

*To order any specialty catalog or directory, complete and return the business reply card at the end of this catalog.*

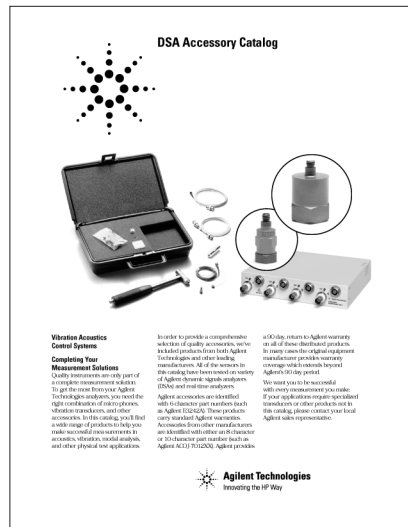

**DSA Accessory Catalog**  
**5980-1846E**

This 8-page catalog presents a wide variety of laboratory-quality sensors and supplies, from Agilent technologies and other leading manufacturers, that complement dynamic signal analyzers (DSAs). These accessories empower you to perform accurate and successful measurements in acoustic, vibration, modal analysis, and other physical test applications.

Free field and pressure microphones, as well as microphone power supplies, preamplifiers, calibrators, and adapters are described.

Vibration transducers and several type of accelerometers, as well as an assortment of cables, are highlighted.

For email addresses and the latest updates, visit Agilent's web site:

[www.agilent.com/find/tmcatalogs](http://www.agilent.com/find/tmcatalogs)

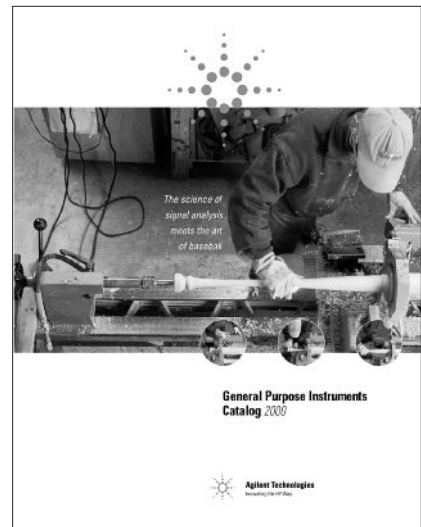

**General Purpose Instruments  
Catalog**  
**5968-8736/EN**

The General Purpose Instruments catalog features tools created to support the design challenges you face every day. We offer a range of performance options that let you choose the right instruments for your unique technical and financial needs.

- Digital Multimeters
- Data Acquisition
- Counters
- Power Meters and Sensors
- Oscilloscopes
- Power Supplies
- Function Generators
- Signal Generators
- Pulse Generators
- Logic Analyzers
- Spectrum Analyzers
- Network Analyzers
- BenchLink Software
- GPIB Cards
- Cables and Connectors

This publication features key instrument specifications and photos, and up-to-date ordering and pricing information. Visit our web site, which includes easy navigation to more detailed product information, application notes, free software downloads, and product demos:

[www.agilent.com/find/gp](http://www.agilent.com/find/gp)

## Subscribe now! Keep up to date with these free newsletters.

To obtain a free subscription to Test & Measurement News or Telecommunications News, contact the Call Center in your region or return the reply card at the back of this catalog.



### Telecommunications News

Each issue of Agilent's *Telecommunications News* provides technical and application information to help you meet the challenges of optimizing the performance of your wireline or wireless networks and of delivering improved services in a rapidly changing environment. This quarterly newsletter is published in English, French, Italian, German, Spanish, and Chinese.

Timely articles feature practical network development, performance, and maintenance advice, training opportunities, product solutions, and more. Many stories include offers for more detailed information about the topic or product. It's easy and convenient to request this literature with a reply card or toll-free number.

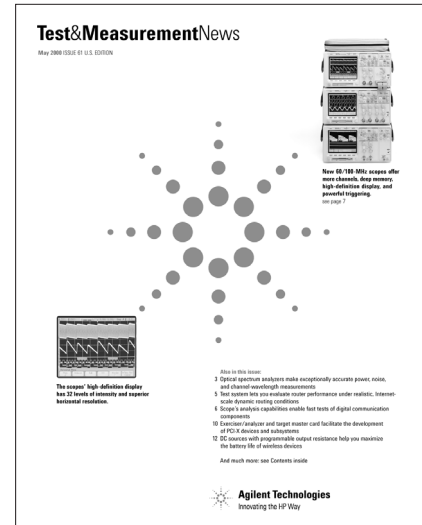

### Test & Measurement News

Keep up to date on the latest in test equipment and technology. With a free subscription to Agilent's *Test and Measurement News*, each quarter you'll see the latest from Agilent. This informative newsletter also describes current application notes, article reprints, catalogs, and other literature. It's easy and convenient to request detailed product information and available literature. Just use the reply card in the issue or call the toll-free number.

We mail *Test & Measurement News* to customers around the world, publishing editions in English, French, Italian, German, Spanish, and Chinese.

## Agilent Authors Provide Complete Information in Two Essential Handbooks

International teams of Agilent experts have produced comprehensive handbooks that answer all the questions you ask about two of the most important elements of the electronics and communications technologies: the tools used in making tests and measurements and how to get the most from them. The capabilities and complexities of today's electronic instruments and instrument systems can be overwhelming. These books demystify the hardware and software and how they work together to perform a function. They start with fundamentals and then progress to include detailed information on all parts of stand-alone instrumentation through instrument systems to software defined instruments, making them important references for the beginner as well as the practicing professional.

### To Order Books

Both books are available at all bookstores where McGraw-Hill reference and professional books are sold. In addition, for more information, or to place an order directly go to McGraw-Hill's web site: [www.ee.mcgraw-hill.com](http://www.ee.mcgraw-hill.com)

You can also order by:

Phone: 1-800-722-4726

Fax: 1-614-755-5645

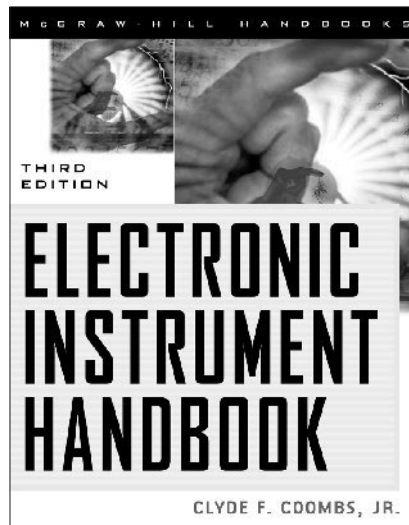

### *The Electronic Instrument Handbook, Third Edition*

by Clyde F. Coombs, Jr.  
1200 pages, Hardcover  
ISBN 0-07-012616-X,

#### Electronic Instruments—Demystified

Heavily revised, this edition includes information on how software, computer, and network technologies combine with traditional hardware to create new capabilities for electronic instruments. This is a one-volume source of information on all aspects of electronic instruments, from basic devices to distributed systems and virtual instruments.

As electronic instruments have become more capable they have become more complex. This book demystifies them. It is the only book that provides descriptions of the technology and functions of instruments and instrument systems: what they are, how they work, how to choose the right one and how to get the most from them.

Information covers underlying technologies of instruments such as A to D converters, microprocessors, software and languages, digital signal processors, transducers, smart transducers, lightwave, VXI, data acquisition systems, virtual instruments, networks, including the Internet, and descriptions of the common issues associated with connecting instruments.

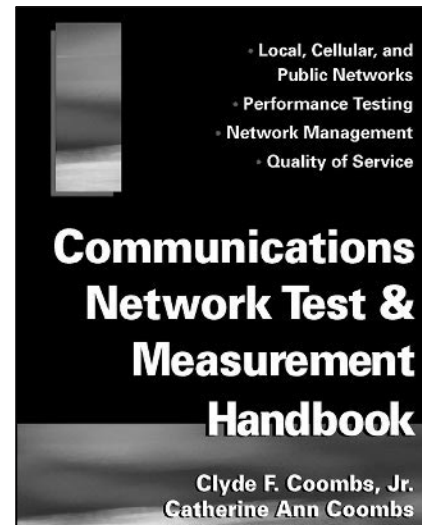

### *Communications Network Test & Measurement Handbook*

by Clyde F. Coombs, Jr. and  
Catherine Ann Coombs  
826 pages, Hardcover  
ISBN 0070126178,

This is a handbook on the measurements and tools required in all phases of the life cycle of a "Communications Network." It provides a comprehensive single-volume reference on the technologies of communications networks and the test, measurement, and monitoring instrumentation needed to ensure effective performance and quality of service. Starting with a discussion of the Open Systems Interface (OSI) model, it describes protocols, transmission errors, and physical connection.

It also includes background information on the technologies, applications, and purposes of communications networks so that the information on test and measurement instruments and processes is clear, and in context. The chapters on instrumentation describe what they are, how they work, and how to get the most from them. In addition, there are descriptions on how to develop the tests that ensure that the network meets local specifications, as well as conforms to international standards.

*In most regions of the world, Agilent Test & Measurement Call Centers offer on-line technical information and sales assistance. A current listing is also available: [www.agilent.com/find/assist](http://www.agilent.com/find/assist)*

## Americas

### Brazil

Agilent Technologies Brasil Ltda.  
 Depto. Teste e Medição  
 Alameda Araguaia, 1142  
 06455-940 - Alphaville - Barueri  
 São Paulo, Brasil  
 Tel: 55 11 7297-3600  
 Fax: 55 11 7297-3933

### Canada

Agilent Technologies Canada Inc.  
 Test & Measurement Product  
 Information  
 2660 Matheson Blvd. East  
 Mississauga, Ontario  
 L4W 5G1  
 Tel: 1-877-894-4414  
 Fax: 1-905-206-4120

Agilent Technologies Canada Inc.  
 Test & Measurement Product  
 Information  
 2670 Queensview Drive  
 Ottawa, Ontario  
 K2B 8K1  
 Tel: 1-800-276-8661  
 Fax: 1-800-746-4866

### Mexico

Agilent Technologies México S. de R.L.  
 de C.V.  
 Prolongacion Reforma No. 700  
 Col. Lomas de Santa Fe  
 01210 Mexico D.F.  
 Tel: (52) 5258-4392  
 Fax: (52) 5258-5714  
 Agilent DIRECTO:(01800)506 4800

### United States

For Quotation/Order Information:  
 Agilent Technologies Co.  
 Test & Measurement Business Center  
 9780 S. Meridian Blvd.  
 Englewood, CO 80112  
 Tel: (800) 829-4444  
 Fax: (800) 829-4433

### For Technical Product Information:

Agilent Technologies Co.  
 Test & Measurement Call Center  
 9780 S. Meridian Blvd.  
 Englewood, CO 80112  
 Tel: (800) 452-4844  
 Fax: (303) 662-3726

### For Federal Government Orders:

Agilent Technologies Co.  
 P.O. Box 1487  
 Rockville, MD 20849-1487  
 Tel: (800) 468-8347  
 Fax: (800) 437-1085

## Asia Pacific

### Australia

Agilent Technologies Australia Pty. Ltd.  
 347 Burwood Highway  
 Forest Hill, VIC 3131  
 Tel: 1-800-629-485  
 Fax: (03) 9210-5947  
 E-mail: [info\\_tmo@agilent.com](mailto:info_tmo@agilent.com)

### China

Agilent Technologies Co. Ltd.  
 HP Building  
 No. 2, Dong San Huan Nan Lu  
 Chao Yang District  
 Beijing 100022, PRC  
 Tel: (86-10) 6564-5500, 800-810-0189  
 Fax: (86-10) 6566-8250

### Hong Kong

Agilent Technologies (HK) Ltd.  
 24/F, Cityplaza One  
 1111 King's Road  
 Taikoo Shing,  
 Hong Kong, SAR  
 Tel: (852) 3197-7889  
 Fax: (852) 2506-9256

### India

Agilent Technologies India Ltd.  
 Telesales Engineer  
 Test & Measurement  
 Chandiwalla Estate  
 Ma Anandmai Ashram Marg, Kalkaji  
 New Delhi 110 019  
 Tel: (91-11) 682-6415  
 Fax: (91-11) 682-6421  
 E-mail: [nisha\\_malhotra@agilent.com](mailto:nisha_malhotra@agilent.com)

### Japan

Agilent Technologies Japan Ltd.  
 Call Center  
 9-1, Takakura-Cho, Hachioji-Shi  
 Tokyo, 192-8510  
 Tel: 0120-421-345  
 0426-56-7832  
 Fax: 0120-421-678  
 0426-56-7840

### Korea, Republic of

Agilent Technologies Korea Ltd.  
 25-12, Yoido-dong  
 Youngdeungpo-ku  
 Seoul, 150-010  
 Tel: (82-2) 2004-5114  
 Fax: (82-2) 2004-5115

### Malaysia

Agilent Technologies Sales (M) Sdn Bhd  
 No. 201, Level 2 Uptown 2  
 2, Jalan SS21/37 Damansara Uptown  
 47400 Petaling Jaya  
 Selangor, Kuala Lumpur  
 Malaysia  
 Tel: 1-800-88-8848  
 Fax: 1-800-80-1664

### New Zealand

Agilent Technologies New Zealand Ltd.  
 25-33 Victoria Street  
 P.O. Box 9348  
 Wellington  
 New Zealand  
 Tel: 0-800-738-378  
 Fax: (04) 495-8950

### Philippines

Agilent Technologies Philippines  
 Corporation  
 11th Floor Asian Star Building  
 Asean Drive corner Singapura Lane  
 Filinvest Corporate City  
 Alabang, Muntinlupa City  
 Philippines, 1780  
 Tel: (632) 842-6802 or  
 1-800-1651-0170  
 Fax: (632) 543-5027 or (632) 543-5029

### Singapore

Agilent Technologies Singapore (Sales)  
 Pte Ltd.  
 438 Alexandra Road  
 Singapore 119958, Alexandra Point  
 Tel: (65) 377-1688  
 Fax: (65) 836-0252  
 E-mail: [TM\\_Asia@agilent.com](mailto:TM_Asia@agilent.com)

### Taiwan

Agilent Technologies Taiwan Ltd.  
 5/F No. 337 Fu-Hsing North Road  
 Taipei, 105  
 Tel: 0800-47866  
 Fax: (886-2) 2718-9860/(886-2)2545-6723

### Thailand

Agilent Technologies (Thailand) Ltd.  
 23rd FL Vibulthani Tower II  
 3199 Rama IV Road, Klongtan  
 Klong Toey, Bangkok 10110  
 Tel: 001-800-65-6206, (02) 661-3999  
 Outside of Bangkok: (088) 225-802  
 Fax: (02) 661-3976, 001-800-65-6317  
 E-mail: [TM\\_Asia@agilent.com](mailto:TM_Asia@agilent.com)



### Europe, Middle East & Africa

#### Austria

Agilent Technologies Österreich GmbH  
Elektronische Messtechnik  
Herrenberger Str. 140  
D-71034 Böblingen  
Deutschland  
aus Österreich  
Tel: +43-1-25125-7006  
Fax: +43-1-25125-6558  
E-Mail: messtechnik\_vertrieb@agilent.com

#### Belgium

Agilent Technologies Belgium S.A./N.V.  
Test & Measurement  
Boulevard de la Woluwe 100  
B-1200 Brussels  
Tel: (32/2) 404 9340  
Fax: (32/2) 404 9395  
E-Mail: customercare\_benelux@agilent.com

#### Denmark

Agilent Technologies A/S  
T&M Direct  
Kongevejen 25  
3460 Birkerød  
Denmark  
Tel: 70131515  
Fax: 45820630  
E-Mail: TM\_DK@agilent.com

#### Finland

Agilent Technologies Finland Oy  
Elektroniikan testausjärjestelmät  
Piispankalliontie 17  
02200 ESPOO  
Finland  
Tel: +358-10-855 2100  
Fax: +358-10-855 2923  
E-Mail: tm\_finland@agilent.com

#### France

Agilent Technologies France  
Agilent DIRECT  
Test et Mesure  
Z.A. de Courtaboeuf  
1, Avenue du Canada  
91947 Les Ulis Cedex  
Tel : 0825 010 700\*  
Fax : 0825 010 701\*  
E-mail: customer-care\_tfo@agilent.com  
\*numéro indigo 0,82 FF HT les 45 secondes en  
journée

#### Germany

Agilent Technologies Deutschland GmbH  
Herrenberger Straße 140  
D-71034 Böblingen  
Tel: (01805) 24-6330\*  
Fax: (01805) 24-6331\*  
\*(0.24 DM/min.)  
E-Mail Address: messtechnik\_vertrieb@agilent.com

#### Ireland

Agilent Technologies Ireland Ltd.  
Agilent Technologies House  
Stradbroke Road  
Blackrock Co.  
Dublin  
Tel: 01 205 4500  
Fax: 01 205 4510

#### Israel

Agilent Technologies  
2, Hashlosha St.  
Bulding B3  
Tel-Aviv 67060  
Tel: (972) 3 68 92 555  
Fax: (972) 3 68 92 556

#### Italy

Agilent Technologies Italiana S.p.A.  
Soluzioni di Misura e Collaudo  
Via P. Gobetti 2/C  
20063 Cernusco s/N (MI)  
Tel: 3902 9260 8484  
Fax: 3902 9210 4069  
E-Mail: agilent\_direct@agilent.com

#### Netherlands

Agilent Technologies Netherlands B.V.  
Test 7 Measurement  
Startbaan 16  
1187 XR Amstelveen  
Tel: 020-547 2111  
Fax: 020-547 2190  
E-Mail: customercare\_benelux@agilent.com

#### Norway

Agilent Technologies Norway AS  
T&M  
Drammensveien 169  
0277 OSLO  
Postboks 564 Skøyen  
0214 OSLO  
Phone Number: +47 23 25 37 00  
Fax: +47 23 25 37 10  
E-Mail: tm\_norway@agilent.com

#### Poland

Malkom  
Ul. Bodycha 18  
02-495 Warszawa  
Tel: 48-22-7230066  
Contact: Beata Sniecikowska

#### Russia

Agilent Technologies  
Kosmodamianskaya naberezhnaya 52/1  
Moscow 113054  
Tel: (7) 095-797-3965  
Fax: (7) 095-797-3902

#### Spain

Agilent Technologies Española, S.A.  
Ctra. N-V1, KM 16,500  
28230 Las Rozas, Madrid  
Tel: 34 91 631.13.23  
Fax: 34 91 631.14.69

#### Sweden

Agilent Technologies Sverige AB  
Test- & Mätssystem  
Skalholtsgatan 9  
S-164 97 KISTA  
Sweden  
Tel: 0200-88 22 55  
Fax: 08-506 486 16  
E-Mail: agilent-direkt-se@agilent.com  
www.agilent.se

#### Switzerland

Agilent Technologies (Schweiz) AG  
Elektronische Meßtechnik  
In der Luberzen 29  
CH 8902 Urdorf/Zürich  
Tel: 41-1-735 9300  
Fax: 41-1-735 9301  
E-Mail: messtechnik\_vertrieb@agilent.com

#### Turkey

Agilent Technologies  
Karum is merkezi no 461  
Ankara 06680  
Tel: (90) 312-468-8212  
Fax: (90) 312-468-8778

#### United Kingdom

Agilent Technologies Ltd.  
Test & Measurement  
Eskdale Road  
Wokingham, Berkshire  
RG41 5DZ  
Tel: 07004 666666  
Fax: 07004 444555  
E-Mail Address: tmo\_assistance@agilent.com

### For countries without Call Centers

Contact the following offices or consult the sales office listing on page 563 for our representative near you. A current listing of our sales offices is also available at: [www.agilent.com/find/assist](http://www.agilent.com/find/assist)

### For other countries in Asia Pacific

Agilent Technologies (HK) Ltd.  
19/F, Cityplaza One,  
1111 King's Road,  
Taikoo Shing,  
Hong Kong, SAR  
Tel: (852) 3197-7777  
Fax: (852) 2506-9284

### For other countries in Eastern Europe, Middle East and Africa

Agilent Technologies  
Middle East/Africa Sales Branch  
Rue de Veyrot, 39  
P.O. Box 364  
1217 Meyrin 1  
Geneva, Switzerland  
Tel: +41 22 780 6136  
Fax: +41 22 780 69 22  
E-Mail: marylin\_breux@agilent.com

### For other countries in Western Europe

Agilent Technologies Netherlands BV  
Test & Measurement  
Startbaan 16  
1187 XR Amstelveen  
Tel: +31-20-547-2111  
Fax: +31-20-547-2190  
E-Mail: customercare\_benelux@agilent.com

### For other countries in Latin America

Agilent Technologies  
Latin America Region Headquarters  
5200 Blue Lagoon Drive, Suite #950  
Miami, Florida 33126  
U.S.A.  
Tel: (305) 267-4245  
(305) 267-4220  
Fax: (305) 267-4286

# Agilent's web site: Get news, updated product and support information, and more, 24 hours a day.

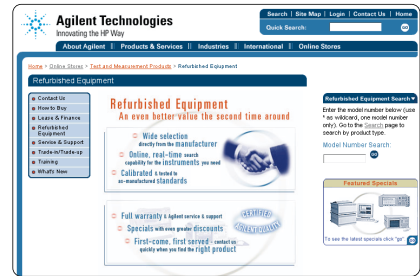
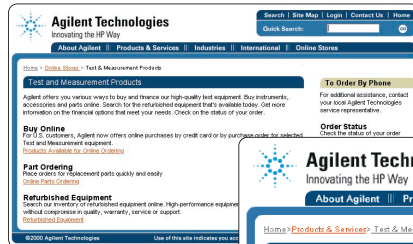

## Resources Available Online

- Product and support information more easily with helpful navigation aids and improved web pages that make it easier to access application notes, product overviews, technical details, frequently asked questions, manuals, software, news releases, education course descriptions and schedules, and much more.

- Updated comparison data and evaluation guides/tools that facilitate product selections
- Helpful application notes, downloadable interactive application notes, tutorials, online models, and other learning and problem-solving material
- Quick access to customer support services
- Information on recommended replacements for discontinued products
- Information in your local language, including updated data on test and measurement seminars and symposiums in your region\*
- The latest information on the status of your Agilent test and measurement order.

## Take Action

Take advantage of the extensive and growing capabilities at Agilent's web site to get fast entry to the test and measurement data and services you need. Save time, gain knowledge and boost your business success—visit our web site often.

Use our online test and measurement resources and services often!  
[www.agilent.com/find/catalogue](http://www.agilent.com/find/catalogue)

\*Availability of this feature may be limited; an expansion program is ongoing. Online purchases require a credit card.